

Super I/O with Temperature Sensing, Quiet Auto Fan and Glue Logic with PECI

PRODUCT FEATURES

Data Brief

- General Features
 - 3.3 Volt Operation (SIO Block is 5 Volt Tolerant)
 - LPC Interface
 - Programmable Wake-up Event Interface
 - PC99, PC2001 Compliant
 - ACPI 2.0 Compliant
 - Multiplexed Command, Address and Data Bus
 - Serial IRQ Interface Compatible with Serialized IRQ Support for PCI Systems
 - PME Interface
 - ISA Plug-and-Play Compatible Register Set
 - 25 General Purpose Input/Output Pins
 - System Management Interrupt
- PECI Interface
 - Supports PECI REQUEST# and PECI AVAILABLE signalling
- AC Power Failure Recovery
- Watchdog Timer
- 2.88MB Super I/O Floppy Disk Controller
 - Licensed CMOS 765B Floppy Disk Controller
 - Software and Register Compatible with SMSC's Proprietary 82077AA Compatible Core
 - Supports One Floppy Drive
 - Configurable Open Drain/Push-Pull Output Drivers
 - Supports Vertical Recording Format
 - 16-Byte Data FIFO
 - 100% IBM® Compatibility
 - Detects All Overrun and Underrun Conditions
 - Sophisticated Power Control Circuitry (PCC) Including Multiple Powerdown Modes for Reduced Power Consumption
 - DMA Enable Logic
 - Data Rate and Drive Control Registers
 - 480 Address, Up to Eight IRQ and Three DMA Options
 - Support 3 Mode FDD
- Enhanced Digital Data Separator
 - 2 Mbps, 1 Mbps, 500 Kbps, 300 Kbps, 250 Kbps Data Rates
 - Programmable Precompensation Modes
- Serial Ports
 - Two Full Function Serial Ports
 - High Speed NS16C550A Compatible UARTs with Send/Receive 16-Byte FIFOs
 - Supports 230k and 460k Baud
 - Programmable Baud Rate Generator
 - Modem Control Circuitry
 - 480 Address and 15 IRQ Options
- Infrared Port
 - Multiprotocol Infrared Interface
 - IrDA 1.0 Compliant
 - SHARP ASK IR
 - 480 Addresses, Up to 15 IRQ
- Multi-Mode™ Parallel Port with ChiProtect™
 - Standard Mode IBM PC/XT®, PC/AT®, and PS/2™ Compatible Bi-directional Parallel Port
 - Enhanced Parallel Port (EPP) Compatible - EPP 1.7 and EPP 1.9 (IEEE 1284 Compliant)
 - IEEE 1284 Compliant Enhanced Capabilities Port (ECP)
 - ChiProtect Circuitry for Protection
 - 960 Address, Up to 15 IRQ and Three DMA Options
- Keyboard Controller
 - 8042 Software Compatible
 - 8 Bit Microcomputer
 - 2k Bytes of Program ROM
 - 256 Bytes of Data RAM
 - Four Open Drain Outputs Dedicated for Keyboard/Mouse Interface
 - Asynchronous Access to Two Data Registers and One Status Register
 - Supports Interrupt and Polling Access
 - 8 Bit Counter Timer
 - Port 92 Support
 - Fast Gate A20 and KRESET Outputs
- Motherboard GLUE Logic
 - IDE Reset Output
 - (4) Buffered PCI Reset Outputs with software controlled reset capability - default transparent
 - Front Panel Reset Debouncing and Power Good Signal Generation
 - Power Supply Turn On Circuitry with Support for power button on PS/2 Keyboard
 - Resume Reset Signal Generation
 - SMBus Isolation Circuitry (2 sets external and 1 set internal for Hardware Monitoring Block)
 - SMBus 2.0 compliant interface for Hardware Monitoring
 - LED Control (2)
- Fan Control
 - 5 PWM (Pulse width Modulation) Outputs
 - Low frequency and high frequency PWM support
 - 6 Fan Tachometer Inputs
 - Programmable automatic fan control based on temperature
 - Interrupt Pin for out-of-limit Fantach Events
 - Fantach events generate PME's

- Temperature Monitor
 - Monitoring of Two Remote Thermal Diodes
 - Processor temperature monitoring by PECl
 - Internal Ambient Temperature Measurement
 - Limit Comparison of all Monitored Values
 - Interrupt Pin for out-of-limit Temperature Indication
 - Thermal events generate PME's
 - Configurable offset for internal or external temperature channels.
- Voltage Monitor
 - Monitor Power supplies (2 at 1.125V, one at 5V, one each for Vccp, Vbat, VTR, and VCC)
 - Limit Comparison of all Monitored Values
 - Interrupt Pin for out-of-limit Voltage Indication
 - Voltage events generate PME's
- Security Features
 - Security Key Register (32 byte) for Device Authentication
- 3 VID (Voltage Identification) Inputs
- Phoenix Keyboard BIOS ROM
- 128 Pin QFP, Lead-Free RoHS Compliant Package

ORDER NUMBER:**SCH5027E-NW FOR 128 PIN, QFN LEAD-FREE ROHS COMPLIANT PACKAGE**

80 ARKAY DRIVE, HAUPPAUGE, NY 11788 (631) 435-6000, FAX (631) 273-3123

Copyright © 2009 SMSC or its subsidiaries. All rights reserved.

Circuit diagrams and other information relating to SMSC products are included as a means of illustrating typical applications. Consequently, complete information sufficient for construction purposes is not necessarily given. Although the information has been checked and is believed to be accurate, no responsibility is assumed for inaccuracies. SMSC reserves the right to make changes to specifications and product descriptions at any time without notice. Contact your local SMSC sales office to obtain the latest specifications before placing your product order. The provision of this information does not convey to the purchaser of the described semiconductor devices any licenses under any patent rights or other intellectual property rights of SMSC or others. All sales are expressly conditional on your agreement to the terms and conditions of the most recently dated version of SMSC's standard Terms of Sale Agreement dated before the date of your order (the "Terms of Sale Agreement"). The product may contain design defects or errors known as anomalies which may cause the product's functions to deviate from published specifications. Anomaly sheets are available upon request. SMSC products are not designed, intended, authorized or warranted for use in any life support or other application where product failure could cause or contribute to personal injury or severe property damage. Any and all such uses without prior written approval of an Officer of SMSC and further testing and/or modification will be fully at the risk of the customer. Copies of this document or other SMSC literature, as well as the Terms of Sale Agreement, may be obtained by visiting SMSC's website at <http://www.smisc.com>. SMSC is a registered trademark of Standard Microsystems Corporation ("SMSC"). Product names and company names are the trademarks of their respective holders.

SMSC DISCLAIMS AND EXCLUDES ANY AND ALL WARRANTIES, INCLUDING WITHOUT LIMITATION ANY AND ALL IMPLIED WARRANTIES OF MERCHANTABILITY, FITNESS FOR A PARTICULAR PURPOSE, TITLE, AND AGAINST INFRINGEMENT AND THE LIKE, AND ANY AND ALL WARRANTIES ARISING FROM ANY COURSE OF DEALING OR USAGE OF TRADE. IN NO EVENT SHALL SMSC BE LIABLE FOR ANY DIRECT, INCIDENTAL, INDIRECT, SPECIAL, PUNITIVE, OR CONSEQUENTIAL DAMAGES; OR FOR LOST DATA, PROFITS, SAVINGS OR REVENUES OF ANY KIND; REGARDLESS OF THE FORM OF ACTION, WHETHER BASED ON CONTRACT; TORT; NEGLIGENCE OF SMSC OR OTHERS; STRICT LIABILITY; BREACH OF WARRANTY; OR OTHERWISE; WHETHER OR NOT ANY REMEDY OF BUYER IS HELD TO HAVE FAILED OF ITS ESSENTIAL PURPOSE, AND WHETHER OR NOT SMSC HAS BEEN ADVISED OF THE POSSIBILITY OF SUCH DAMAGES.

General Description

The SCH5027E is a 3.3V (Super I/O Block is 5V tolerant) PC99/PC2001 compliant Super I/O controller with an LPC interface. SCH5027E also includes Hardware Monitoring capabilities, enhanced Security features, Power Control logic and Motherboard Glue logic.

The SCH5027E's hardware monitoring capability includes temperature, voltage and fan speed monitoring. It has the ability to alert the system to out-of-limit conditions and automatically control the speeds of multiple fans. There are four analog inputs for monitoring external voltages, two at 1.125V, one at 5V and one at 2.25V for V_{ccp} (core processor voltage). There is also internal monitoring of the SIO's VCC, VTR, and Vbat power supplies. The SCH5027E is capable of monitoring two external diodes, one internal ambient temperature sensor or retrieving temperatures from external processors that implement the PECl interface. The PECl implementation in the SCH5027E includes support for the PECl REQUEST# and PECl AVAILABLE signals that are used to wake processors from the C3/C4sleep states. There are three pulse width modulation (PWM) outputs with high frequency support that may be controlled by the auto fan block, as well as four fan tachometer inputs. There are two additional software controlled PWM inputs with associated tachometer inputs that may be used to monitor fans. The nHWM_INT pin is implemented to indicate out-of-limit temperature, voltage, and FANTACH conditions. The hardware monitoring block of the SCH5027E is accessible via the System Management Bus (SMBus). The same interrupt event reported on the nHWM_INT pin also creates PME wake-up events and speaker alarm annunciation.

The SCH5027E also allows for a two or three piece linear fan function.

The Motherboard Glue logic includes various power management and system logic including generation of nRSMRST, SMBus buffers, and buffered PCI reset outputs.

The SCH5027E incorporates complete legacy Super I/O functionality including an 8042 based keyboard and mouse controller, an IEEE 1284, EPP, and ECP compatible parallel port, one serial port that is 16C550A UART compatible, one IrDA 1.0 infrared ports, and a floppy disk controller with SMSC's true CMOS 765B core and enhanced digital data separator. The true CMOS 765B core provides 100% compatibility with IBM PC/XT and PC/AT architectures and is software and register compatible with SMSC's proprietary 82077AA core. System related functionality, which offers flexibility to the system designer, General Purpose I/O control functions, control of two LED's, and fan control using fan tachometer inputs and pulse width modulator (PWM) outputs.

The SCH5027E is ACPI 1.0/2.0 compatible and therefore supports multiple low power-down modes. It incorporates sophisticated power control circuitry (PCC), which includes support for keyboard and mouse wake-up events.

The SCH5027E supports the ISA Plug-and-Play Standard register set (Version 1.0a). The I/O Address, DMA Channel and hardware IRQ of each logical device in the SCH5027E may be reprogrammed through the internal configuration registers. There are up to 480 (960 - Parallel Port) I/O address location options, a Serialized IRQ interface, and Three DMA channels.

Block Diagram

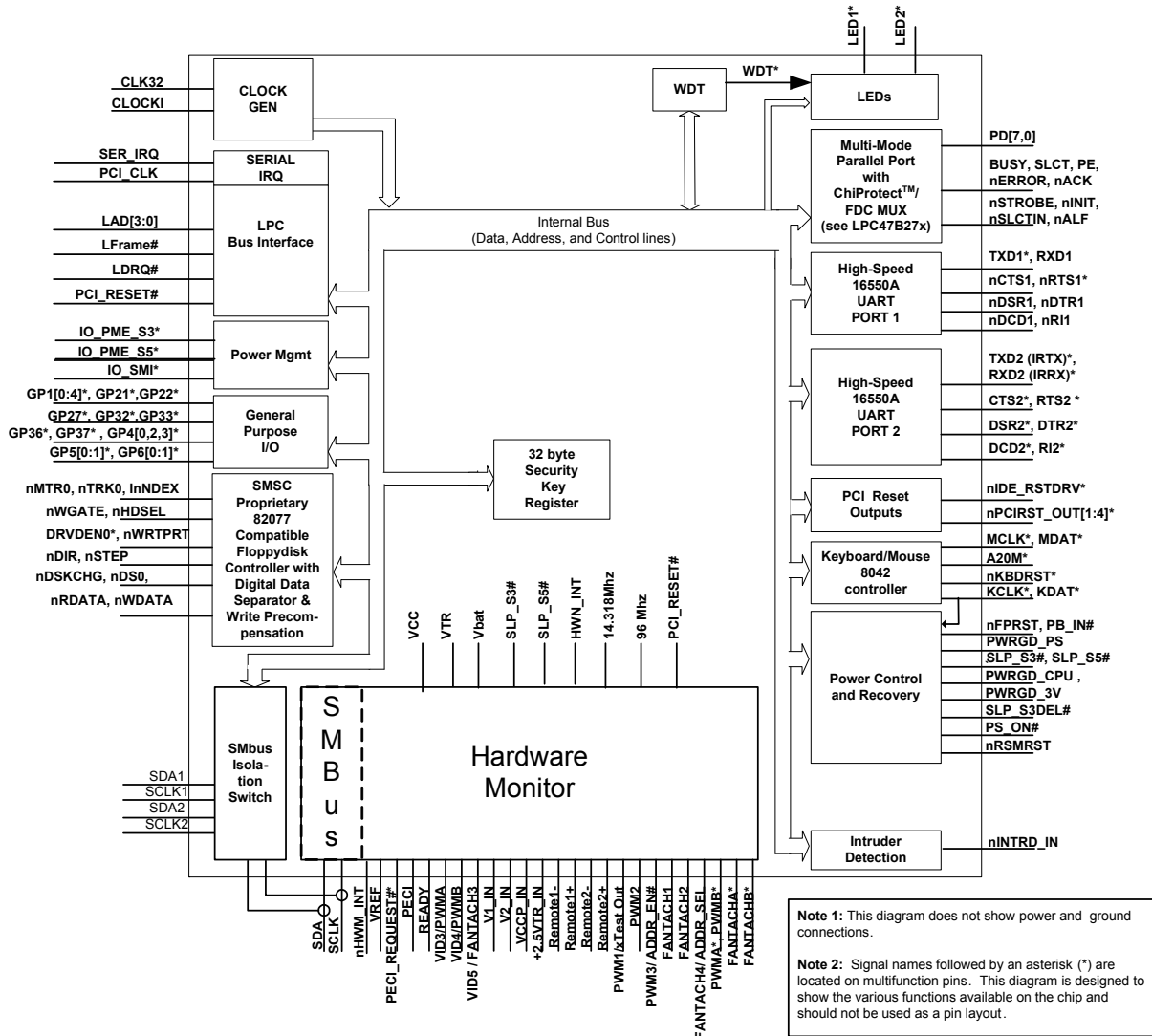

Figure 1 SCH5027E Block Diagram

Chapter 2 Package Outline

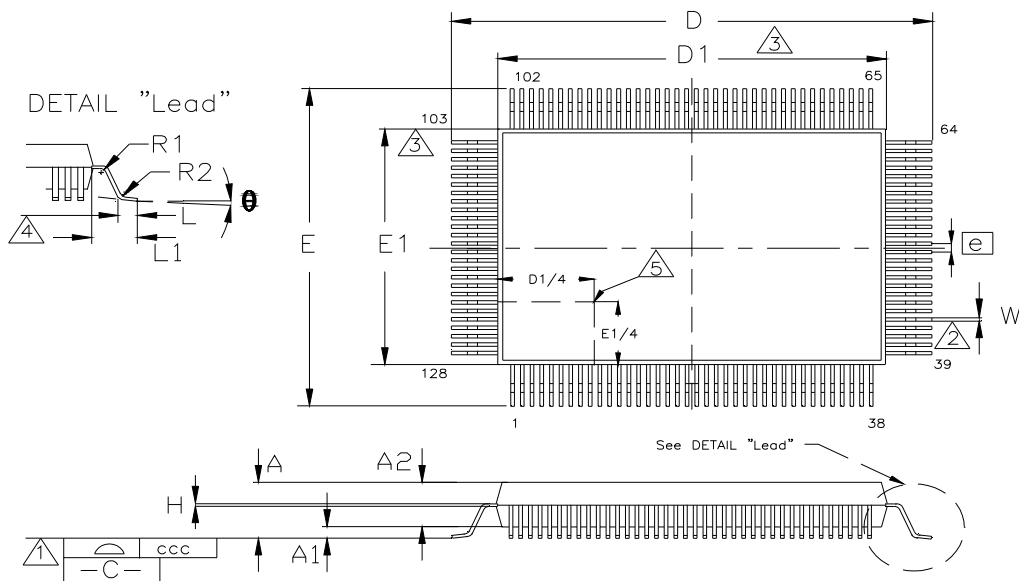

Figure 3 128 Pin QFP Package Outline, 14X20X2.7 Body, 3.2 mm Footprint

Table 1 128 Pin QFP Package Parameters

	MIN	NOMINAL	MAX	REMARKS
A	~	~	3.4	Overall Package Height
A1	0.05	~	0.5	Standoff
A2	2.55	~	3.05	Body Thickness
D	23.00	23.20	23.40	X Span
D1	19.90	20.00	20.10	X body Size
E	17.00	17.20	17.40	Y Span
E1	13.90	14.00	14.10	Y body Size
H	0.09	~	0.20	Lead Frame Thickness
L	0.73	0.88	1.03	Lead Foot Length
L1	~	1.60	~	Lead Length
e	0.50 Basic			Lead Pitch
q	0°	~	7°	Lead Foot Angle
W	0.10	~	0.30	Lead Width
R1	0.08	~	~	Lead Shoulder Radius
R2	0.08	~	0.30	Lead Foot Radius
ccc	~	~	0.08	Coplanarity

Notes:

1. Controlling Unit: millimeter.
2. Controlling Unit: millimeter.
3. Tolerance on the position of the leads is ± 0.04 mm maximum.
4. Package body dimensions D1 and E1 do not include the mold protrusion.
5. Maximum mold protrusion is 0.25 mm.
6. Dimension for foot length L measured at the gauge plane 0.25 mm above the seating plane.
7. Details of pin 1 identifier are optional but must be located within the zone indicated.

Компания «Life Electronics» занимается поставками электронных компонентов импортного и отечественного производства от производителей и со складов крупных дистрибьюторов Европы, Америки и Азии.

С конца 2013 года компания активно расширяет линейку поставок компонентов по направлению коаксиальный кабель, кварцевые генераторы и конденсаторы (керамические, пленочные, электролитические), за счёт заключения дистрибьюторских договоров

Мы предлагаем:

- Конкурентоспособные цены и скидки постоянным клиентам.
- Специальные условия для постоянных клиентов.
- Подбор аналогов.
- Поставку компонентов в любых объемах, удовлетворяющих вашим потребностям.
- Приемлемые сроки поставки, возможна ускоренная поставка.
- Доставку товара в любую точку России и стран СНГ.
- Комплексную поставку.
- Работу по проектам и поставку образцов.
- Формирование склада под заказчика.
- Сертификаты соответствия на поставляемую продукцию (по желанию клиента).
- Тестирование поставляемой продукции.
- Поставку компонентов, требующих военную и космическую приемку.
- Входной контроль качества.
- Наличие сертификата ISO.

В составе нашей компании организован Конструкторский отдел, призванный помогать разработчикам, и инженерам.

Конструкторский отдел помогает осуществить:

- Регистрацию проекта у производителя компонентов.
- Техническую поддержку проекта.
- Защиту от снятия компонента с производства.
- Оценку стоимости проекта по компонентам.
- Изготовление тестовой платы монтаж и пусконаладочные работы.



Тел: +7 (812) 336 43 04 (многоканальный)
Email: org@lifeelectronics.ru