

THIS DRAWING IS UNPUBLISHED. RELEASED FOR PUBLICATION 20
 © COPYRIGHT 20 BY - ALL RIGHTS RESERVED.

LOC		DIST		REVISIONS			
P	LTR	DESCRIPTION	DATE	DWN	APVD		
-	-	A	REVISED PER ECR-16-018289	30DEC2016	RK	PO	

1.70 DISTANCE FROM COG TO CENTER OF PICK UP ZONE

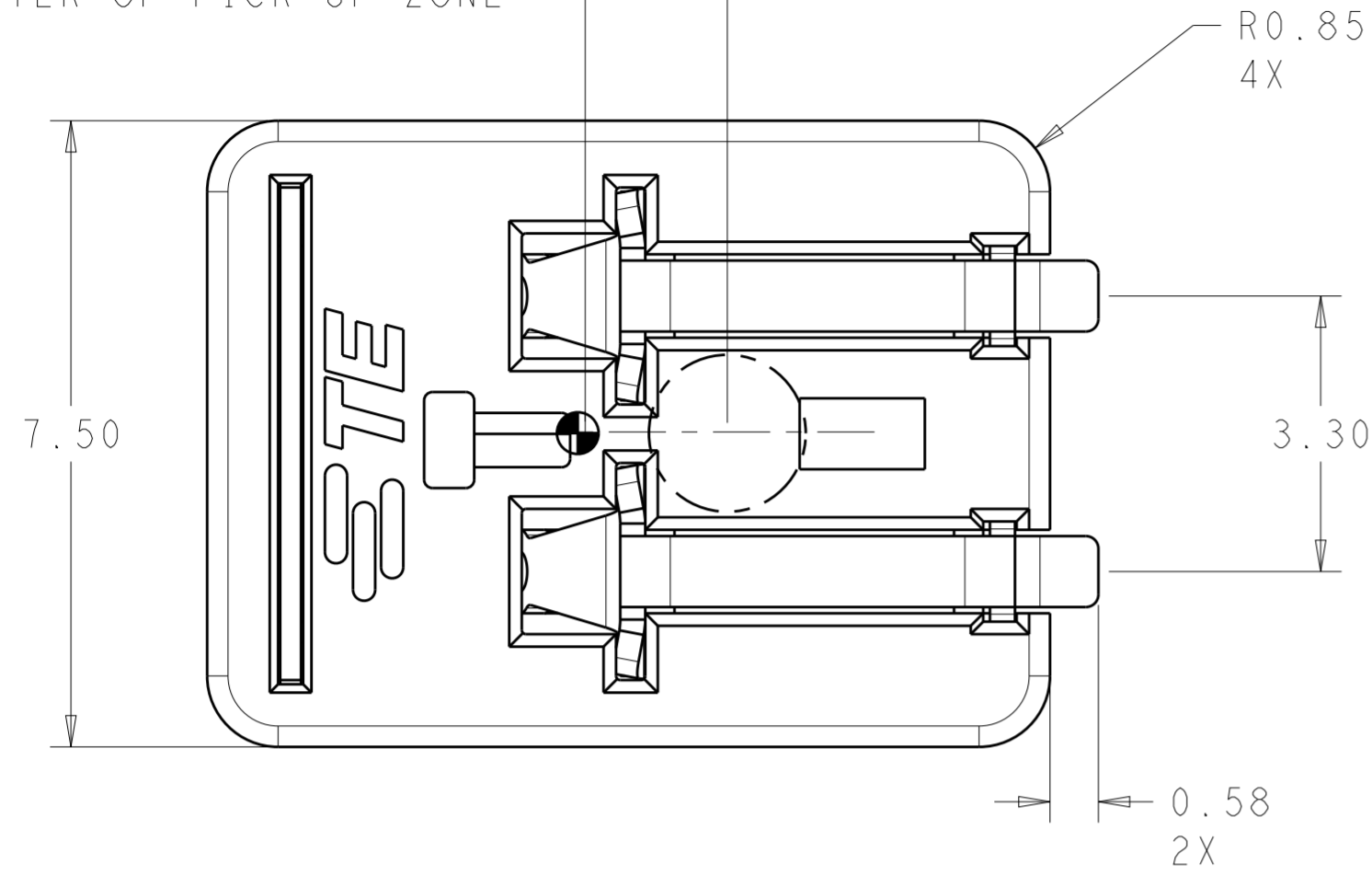

- 1 MATERIALS AND FINISH:
 -HOUSING AND COVER: THERMOPLASTIC, COLOR: NATURAL
 -CONTACTS: COPPER ALLOY, FINISH: Sn OVER Ni
 -HOLD DOWN: COPPER ALLOY, FINISH: Sn OVER Ni
- 2. MUST COMPLY WITH DIRECTIVE 2002/95/EC (ROHS)
- 3. THIS PRODUCT HAS NOT COMPLETED VALIDATION TESTING.
- 4. PACKAGED IN TAPE AND REEL
- 5 PCB EDGE TO BE DETERMINED BY CUSTOMER APPLICATION
- 6 TO BE USED WITH 1.0±10% (OR 0.8±10%) PCB THICKNESS
- 7 TO BE USED WITH 1.6±10% PCB THICKNESS
- 8 DIMENSION SHOWN IS RECOMMENDED SOLDER MASK OPENING

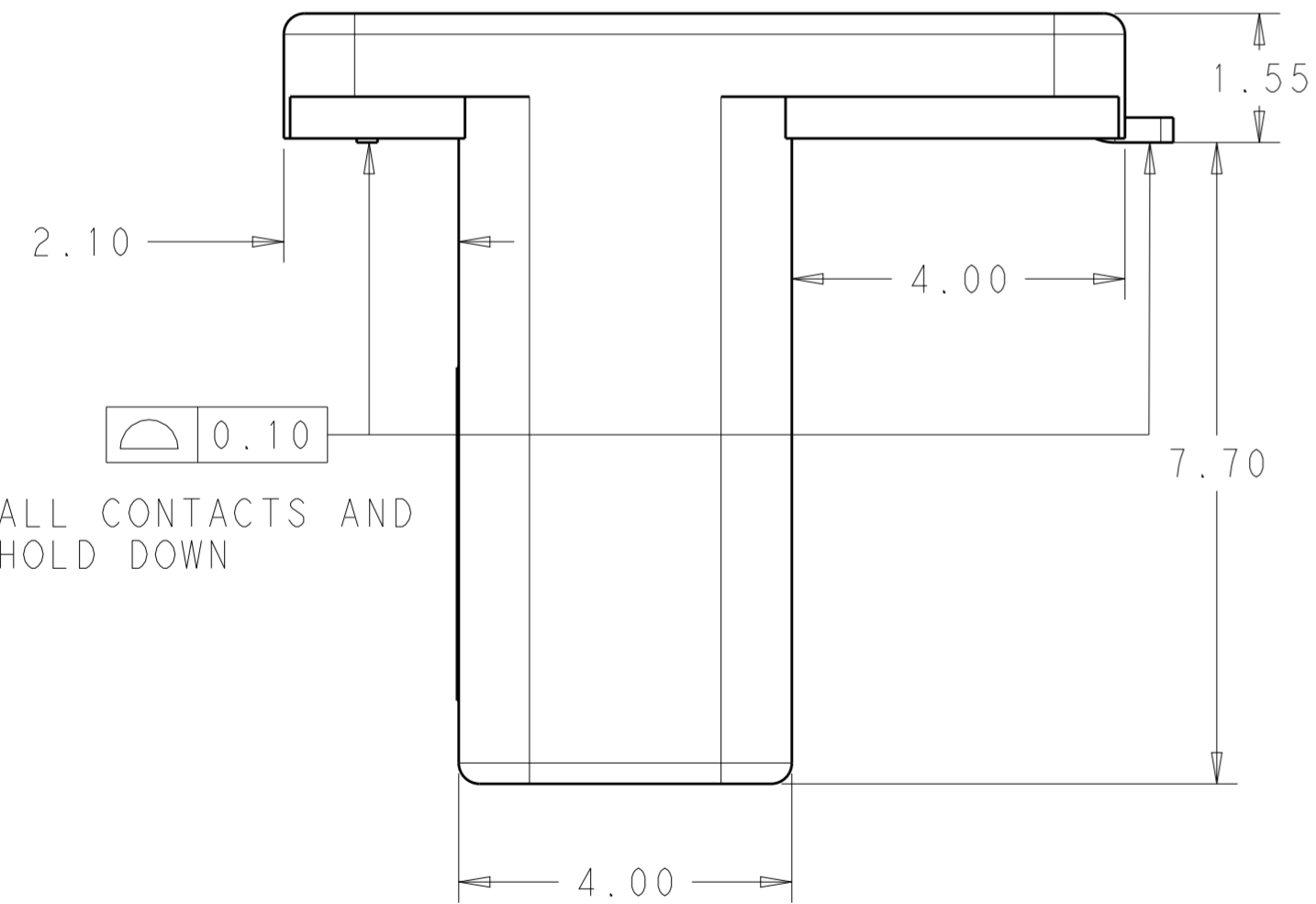

ALL CONTACTS AND HOLD DOWN

SEE VIEW E

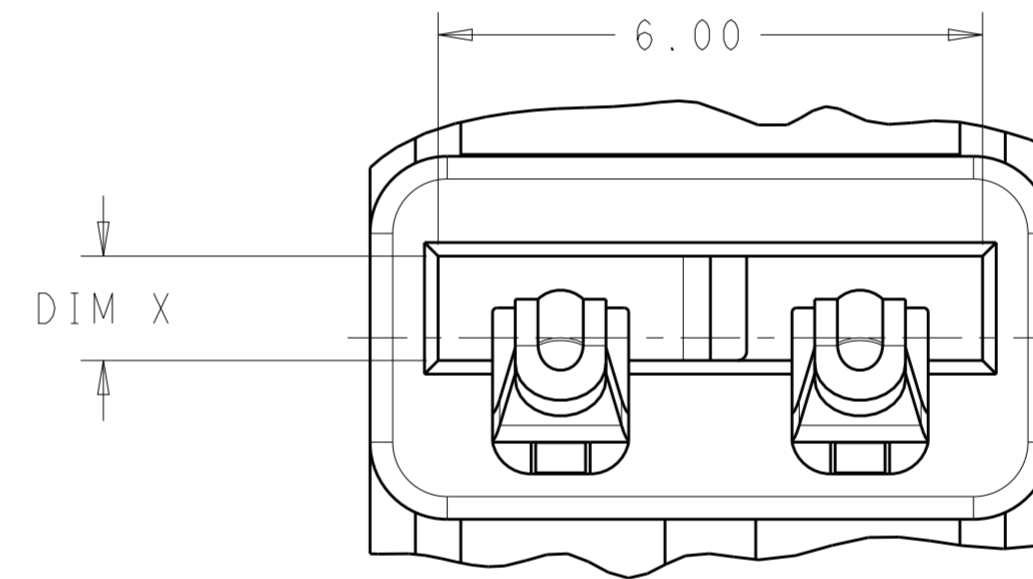

VIEW E
SCALE 12:1

2213188-1, -2

1.6	WITH COVER	1.44 - 1.75	1.81	2213188-4
1.0	WITH COVER	0.72 - 1.10	1.15	2213188-3
1.6	W/O COVER	1.44 - 1.75	1.81	2213188-2
1.0	W/O COVER	0.72 - 1.10	1.15	2213188-1
MARKING	COVER	DIM B	DIM X	PART NO.

THIS DRAWING IS A CONTROLLED DOCUMENT.		DWN C. DAILY 25OCT2012	TE Connectivity	
		CHK C. GINGRICH 25OCT2012		
DIMENSIONS: mm		TOLERANCES UNLESS OTHERWISE SPECIFIED:		NAME ASSEMBLY, CARD EDGE INVERTED THROUGH BOARD
		0 PLC ±	1 PLC ±0.2	PRODUCT SPEC 108-32041
		2 PLC ±0.15	3 PLC ±	APPLICATION SPEC 114-32054
		4 PLC ±	ANGLES ±2°	SIZE A200779
MATERIAL		FINISH		DRAWING NO C-2213188
				RESTRICTED TO
				SCALE 7:1 SHEET 1 OF 4 REV A

THIS DRAWING IS UNPUBLISHED. RELEASED FOR PUBLICATION 20
 © COPYRIGHT 20 BY - ALL RIGHTS RESERVED.

LOC		DIST		REVISIONS			
P	LTR	DESCRIPTION	DATE	DWN	APVD		
-	-	SEE SHEET 1	-	-	-		

R1.25

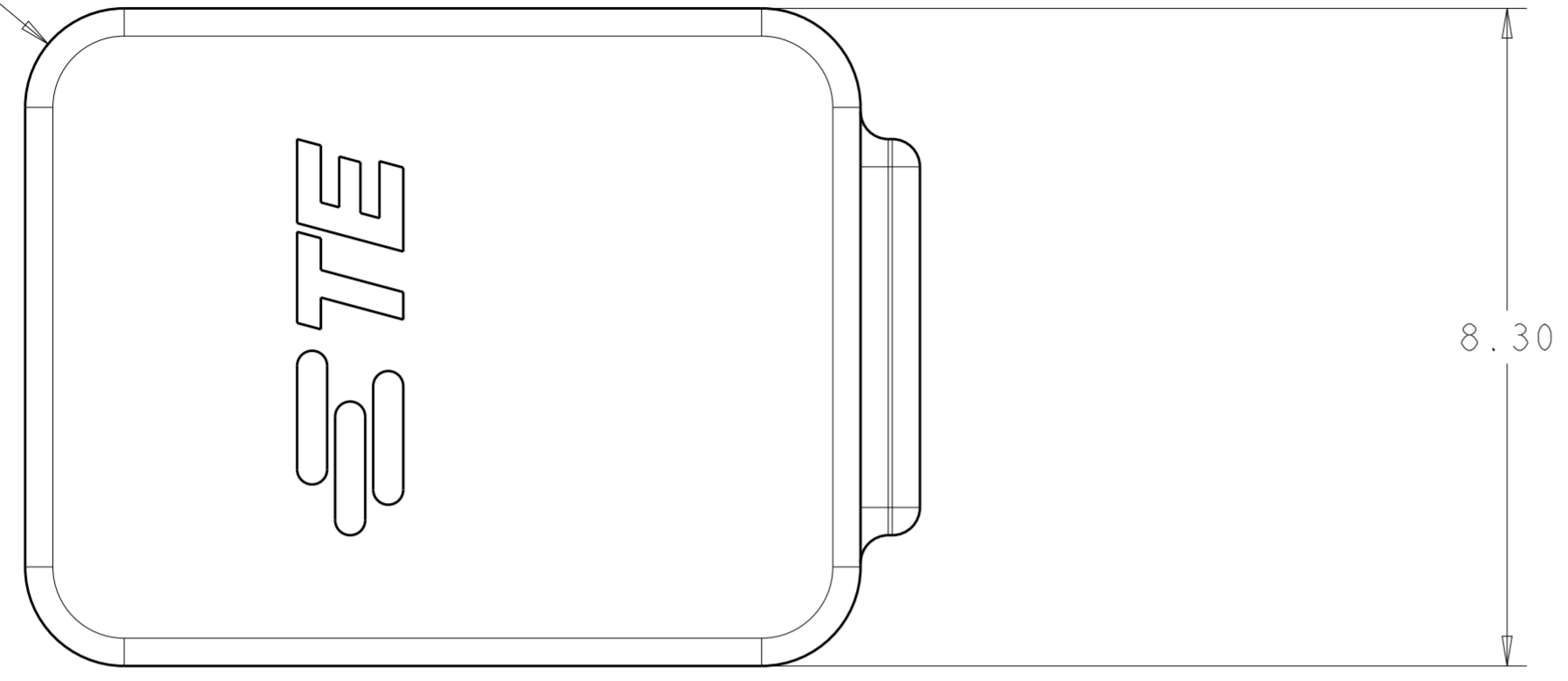

SCALE 12:1

2213188-3, -4

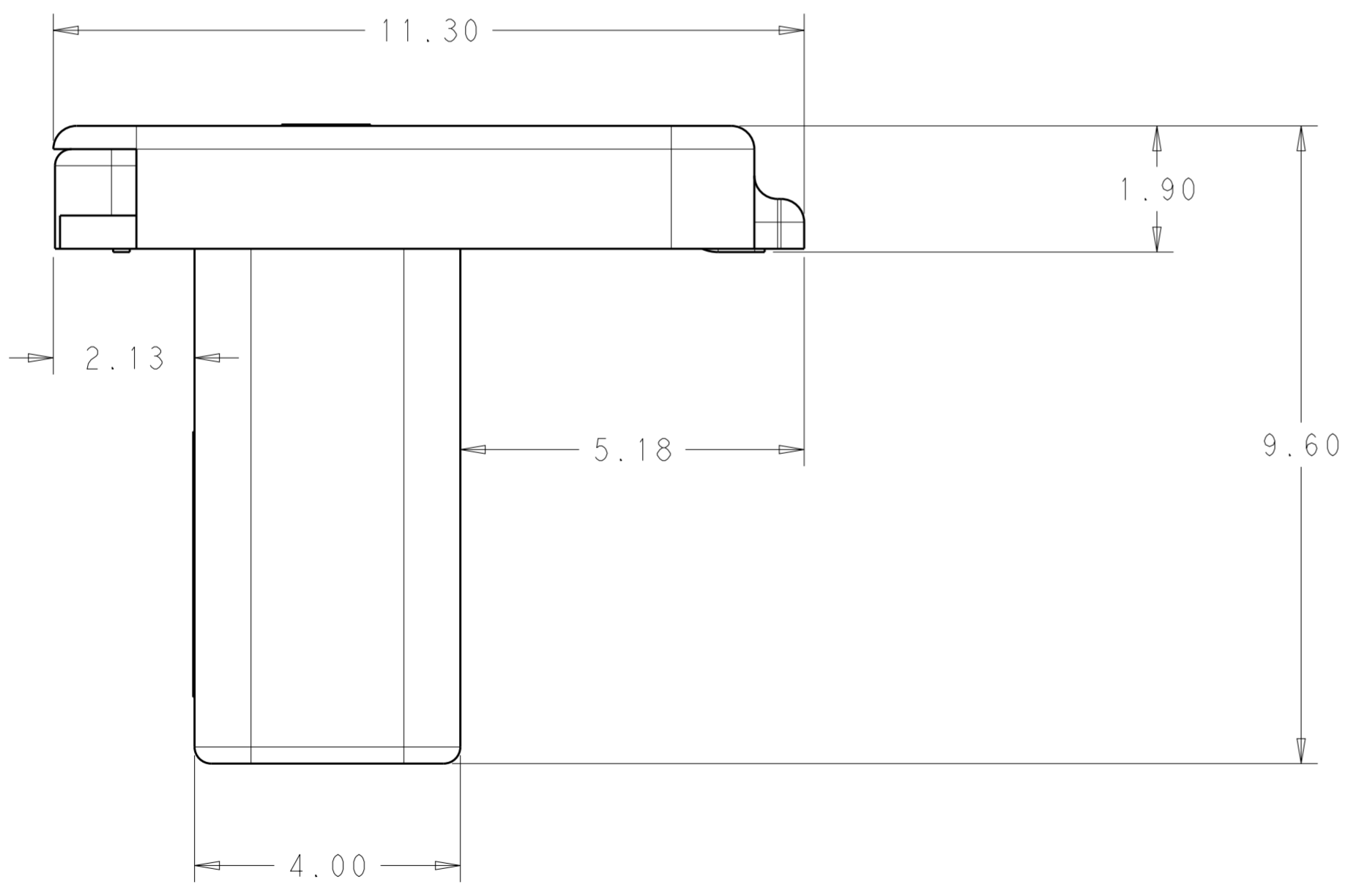

THIS DRAWING IS A CONTROLLED DOCUMENT.		DWN C. DAILY 25OCT2012	STC TE Connectivity	
		CHK C. GINGRICH 25OCT2012		
DIMENSIONS: mm		APVD -		NAME ASSEMBLY, CARD EDGE INVERTED THROUGH BOARD
TOLERANCES UNLESS OTHERWISE SPECIFIED: 0 PLC ± 1 PLC ±0.2 2 PLC ±0.15 3 PLC ± 4 PLC ± ANGLES ±2° FINISH		PRODUCT SPEC 108-32041		SIZE A200779
MATERIAL -		APPLICATION SPEC 114-32054		CAGE CODE C-2213188
		WEIGHT -		DRAWING NO C-2213188
		CUSTOMER DRAWING		RESTRICTED TO -
		SCALE 7:1		SHEET 2 OF 4 REV A

THIS DRAWING IS UNPUBLISHED. RELEASED FOR PUBLICATION 20
 © COPYRIGHT 20 BY - ALL RIGHTS RESERVED.

LOC		DIST		REVISIONS			
P	LTR	DESCRIPTION	DATE	DWN	APVD		
-	-	SEE SHEET 1	-	-	-		

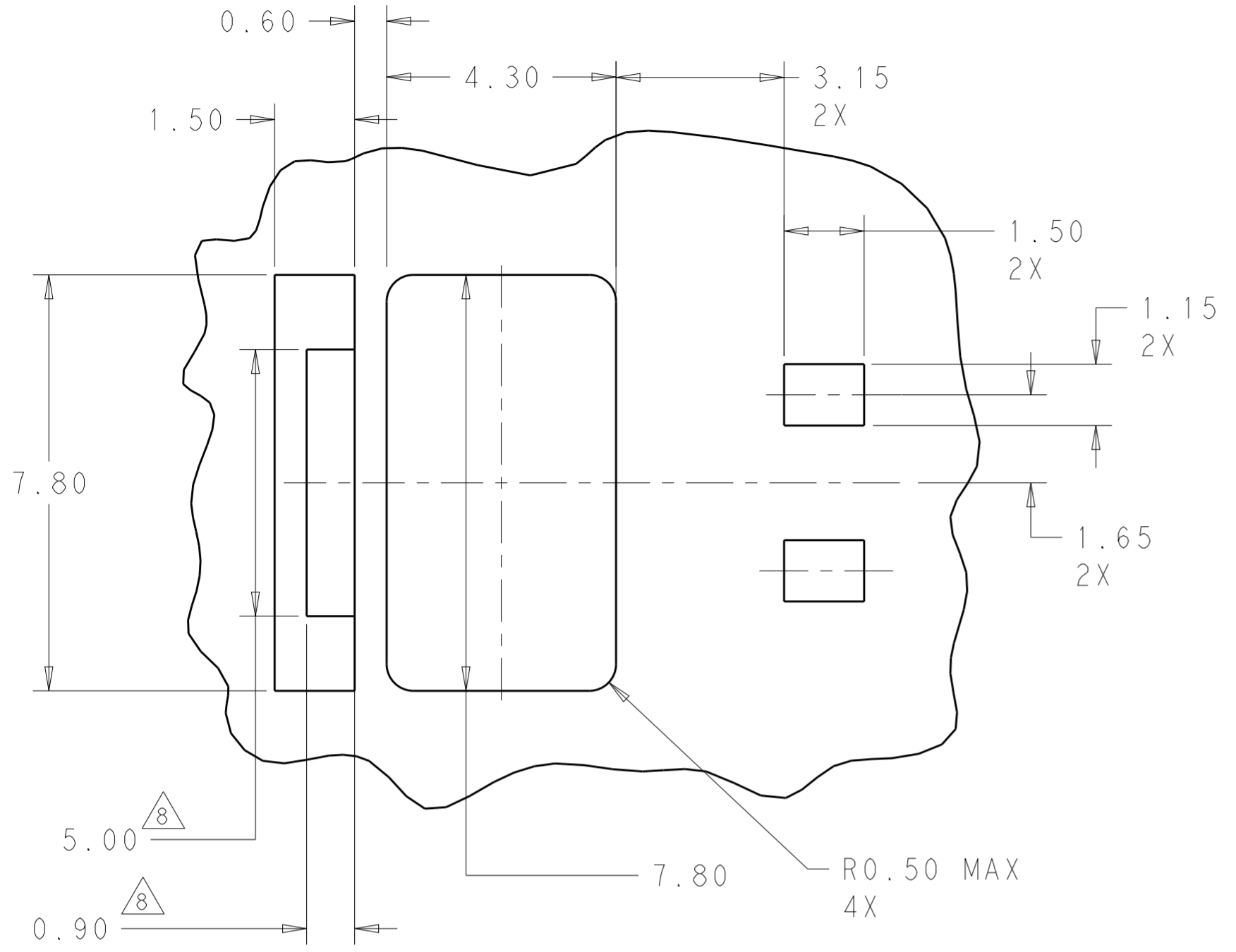

MOUNTING PCB LAYOUT
SCALE 10:1

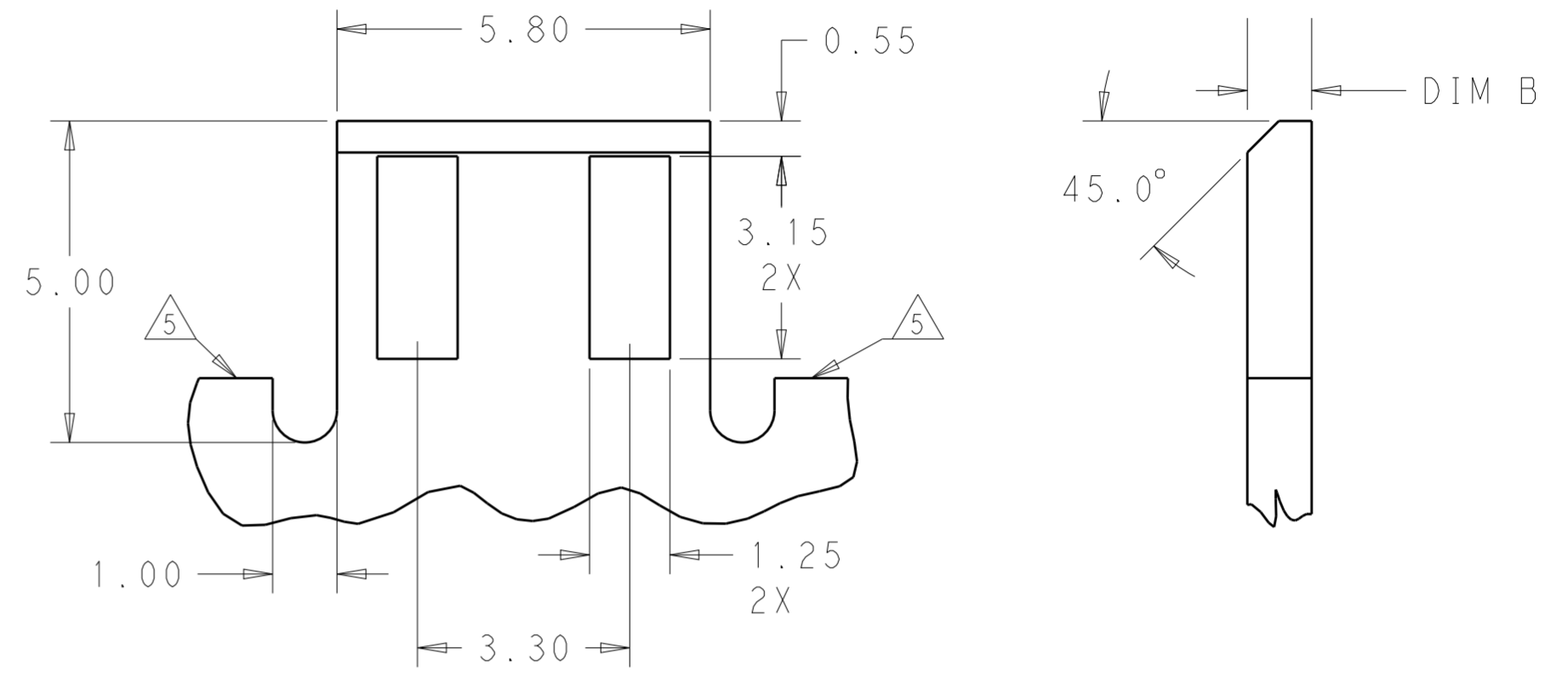

MATING PCB DETAILS (PREFERRED OPTION)
SCALE 10:1

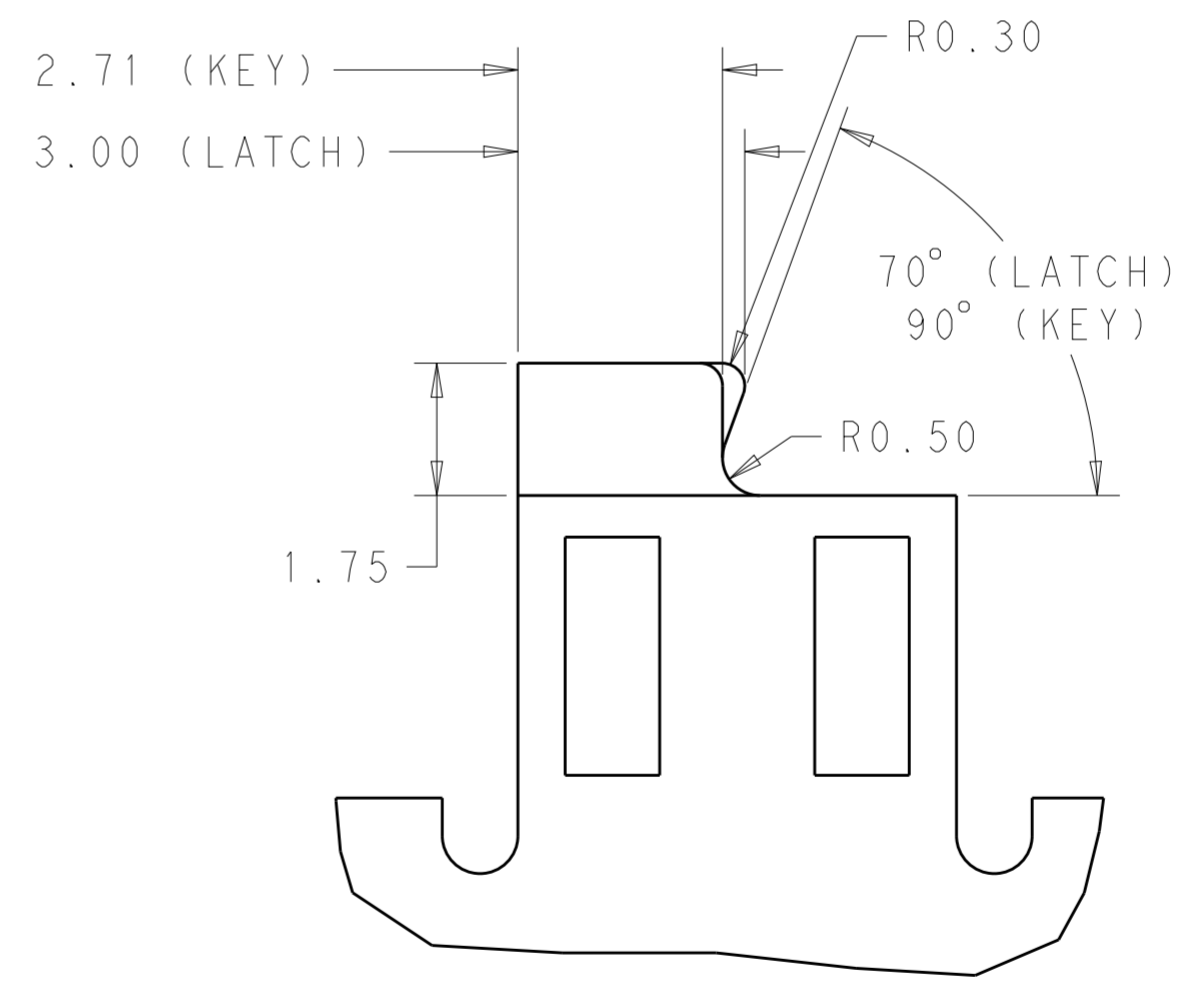

MATING PCB DETAILS (KEY AND LATCH OPTIONS)
SCALE 10:1

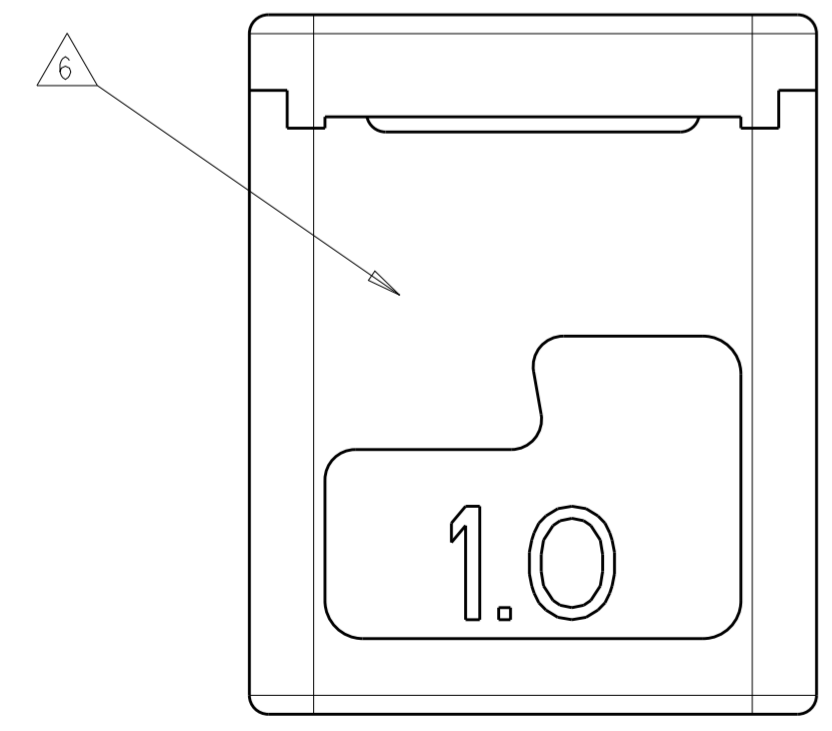

2213188-1, -3
SCALE 10:1

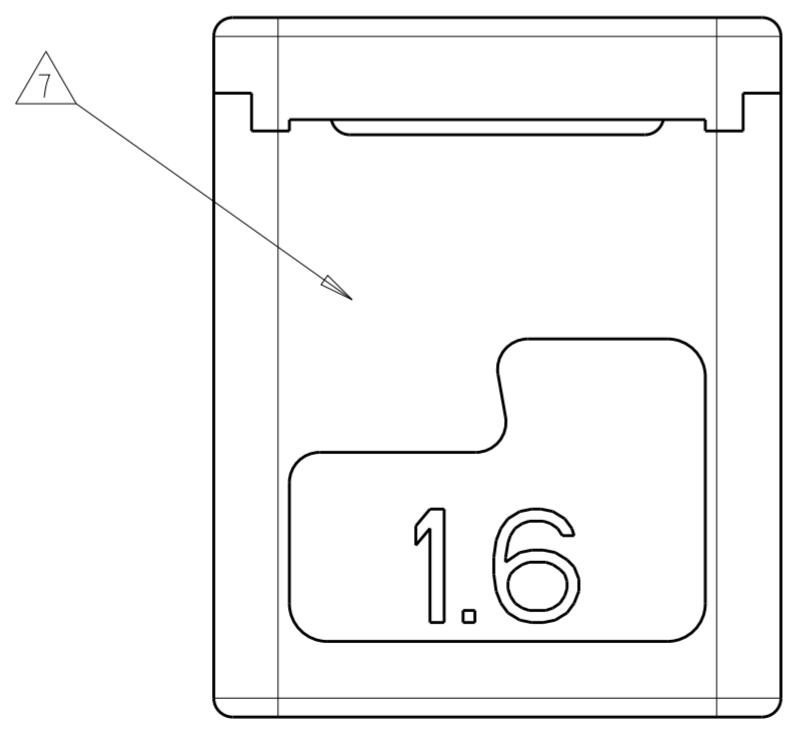

2213188-2, -4
SCALE 10:1

THIS DRAWING IS A CONTROLLED DOCUMENT.		DWN C. DAILY 25OCT2012	STE TE Connectivity	
		CHK C. GINGRICH 25OCT2012		
DIMENSIONS: mm	TOLERANCES UNLESS OTHERWISE SPECIFIED:	APVD -	NAME ASSEMBLY, CARD EDGE INVERTED THROUGH BOARD	RESTRICTED TO -
	0 PLC ± 1 PLC ±0.2 2 PLC ±0.15 3 PLC ± 4 PLC ±	PRODUCT SPEC 108-32041	SIZE A200779	CAGE CODE C-2213188
MATERIAL	ANGLES ±2° FINISH	APPLICATION SPEC 114-32054	DRAWING NO C-2213188	SCALE 7:1
		WEIGHT -	SHEET 3 OF 4	REV A
		CUSTOMER DRAWING		

THIS DRAWING IS UNPUBLISHED. RELEASED FOR PUBLICATION 20
 © COPYRIGHT 20 BY - ALL RIGHTS RESERVED.

LOC		DIST		REVISIONS			
P	LTR	DESCRIPTION	DATE	DWN	APVD		
-	-	SEE SHEET 1	-	-	-		

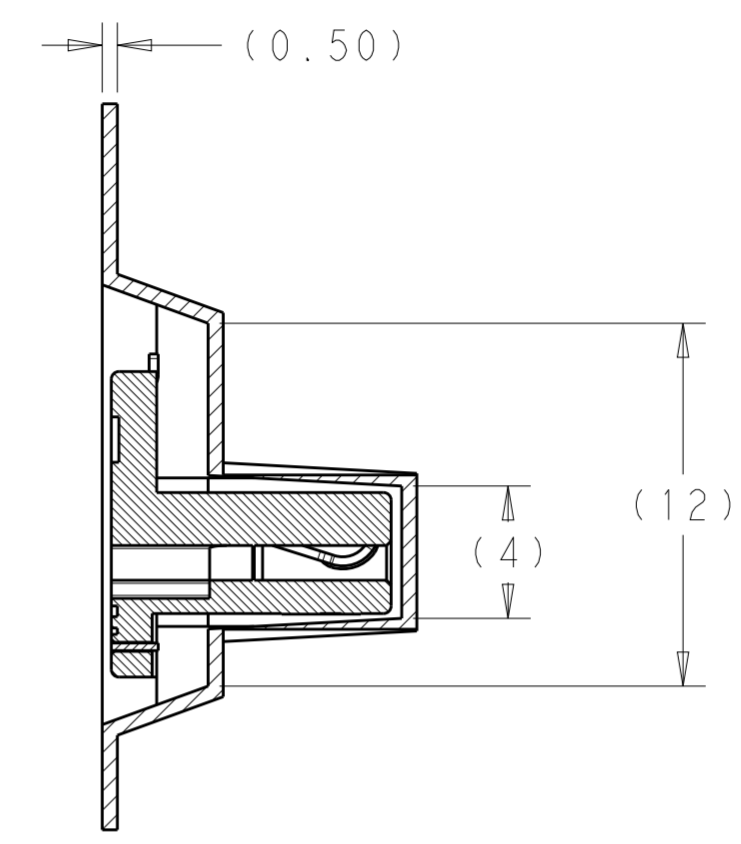
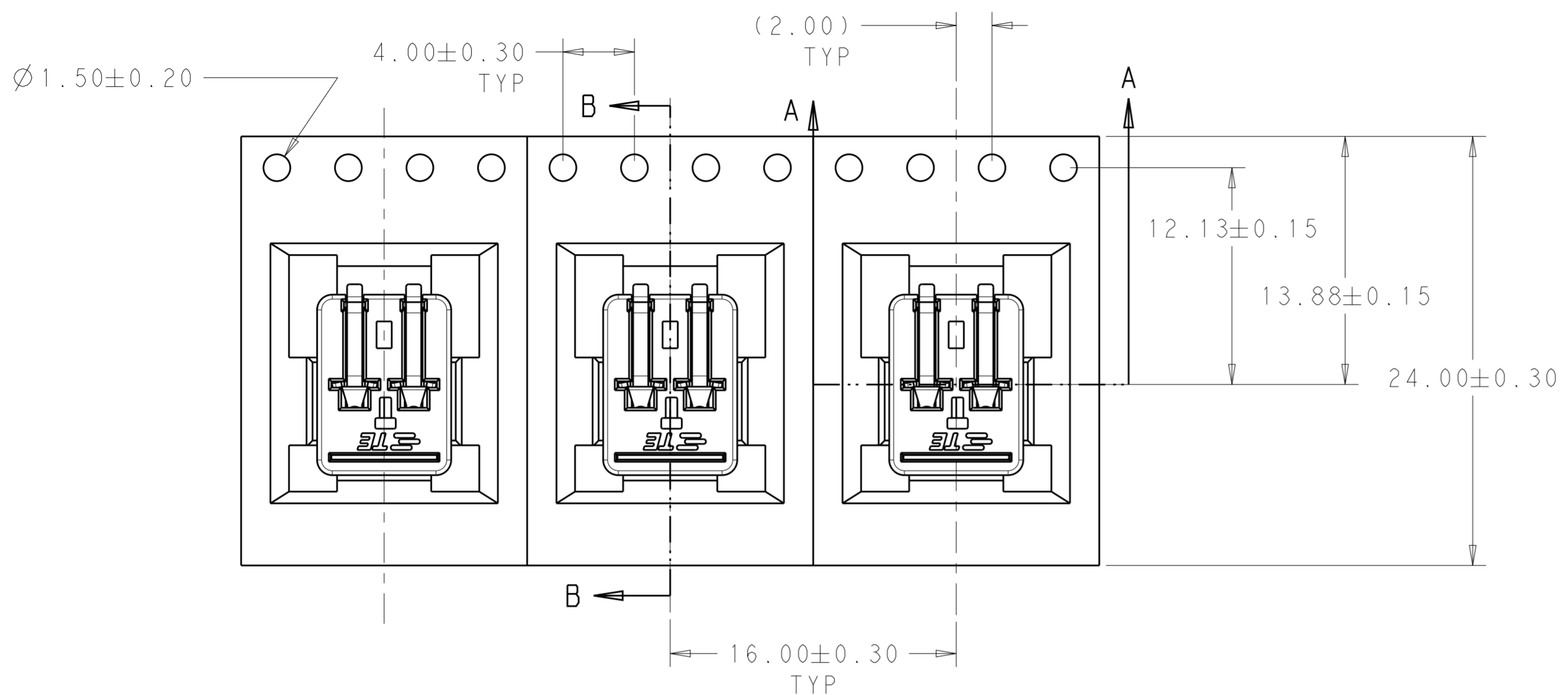

SECTION B-B

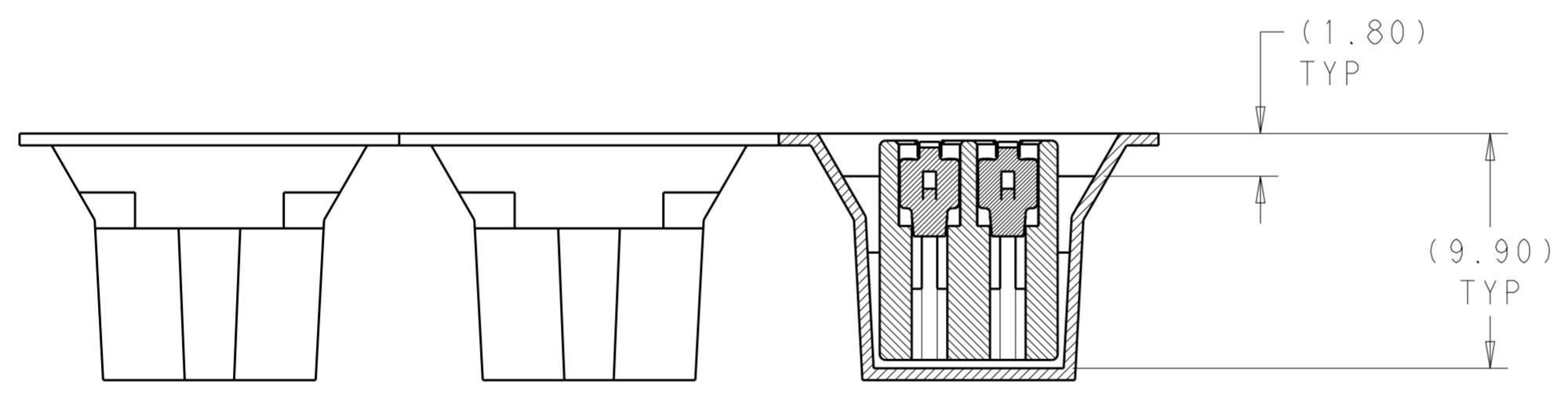

SECTION A-A

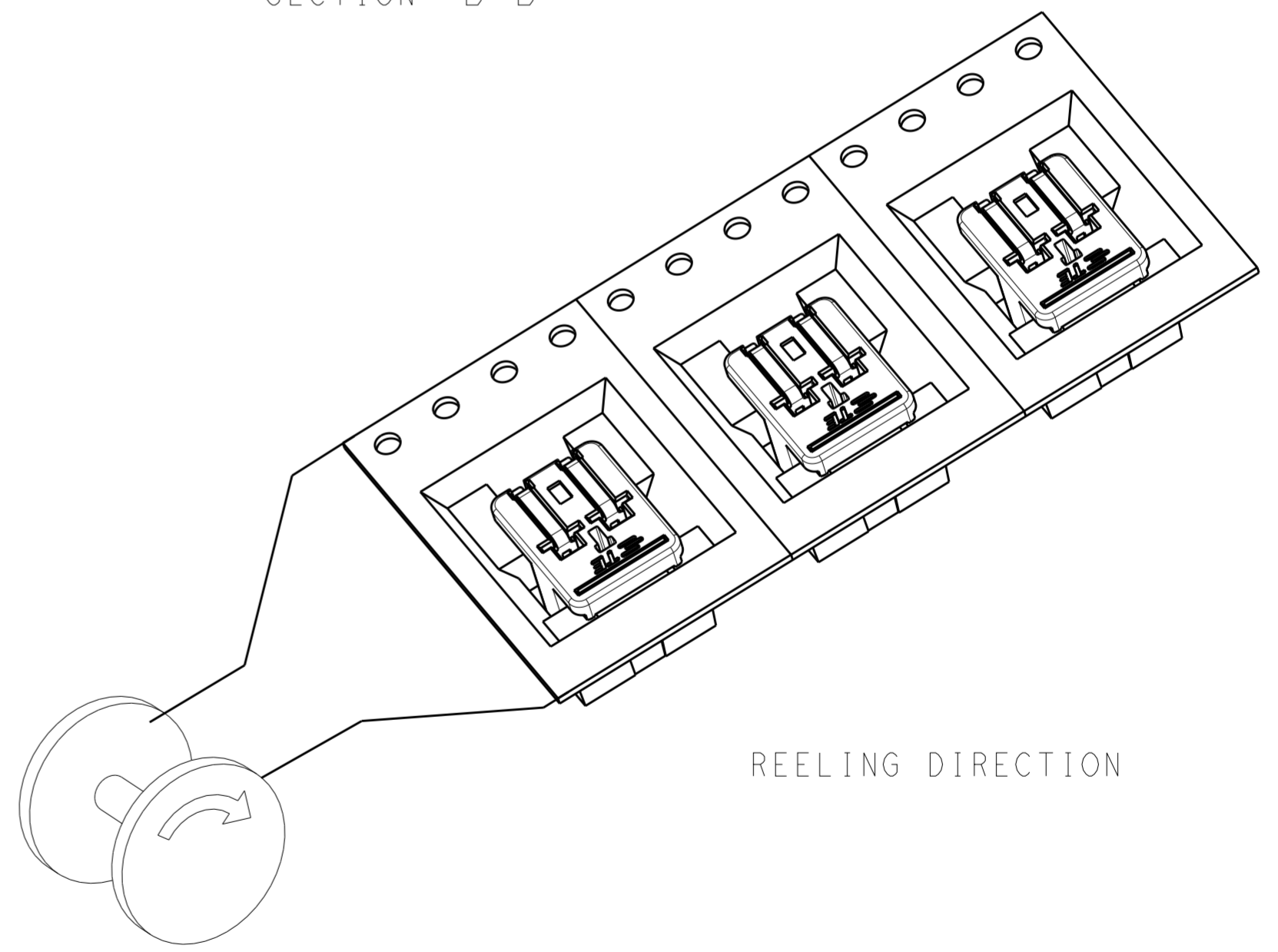

REELING DIRECTION

PACKAGING FOR 2213188-1 SHOWN

THIS DRAWING IS A CONTROLLED DOCUMENT.		DWN C. DAILY 25OCT2012	TE Connectivity	
		CHK C. GINGRICH 25OCT2012		
DIMENSIONS: mm		TOLERANCES UNLESS OTHERWISE SPECIFIED:		NAME ASSEMBLY, CARD EDGE INVERTED THROUGH BOARD
<ul style="list-style-type: none"> 0 PLC ± 1 PLC ±0.2 2 PLC ±0.15 3 PLC ± 4 PLC ± ANGLES ±2° FINISH 		PRODUCT SPEC 108-32041	SIZE A200779	
MATERIAL		APPLICATION SPEC 114-32054	DRAWING NO C-2213188	
		WEIGHT	RESTRICTED TO	
		CUSTOMER DRAWING	SCALE 7:1 SHEET 4 OF 4 REV A	

Компания «Life Electronics» занимается поставками электронных компонентов импортного и отечественного производства от производителей и со складов крупных дистрибьюторов Европы, Америки и Азии.

С конца 2013 года компания активно расширяет линейку поставок компонентов по направлению коаксиальный кабель, кварцевые генераторы и конденсаторы (керамические, пленочные, электролитические), за счёт заключения дистрибьюторских договоров

Мы предлагаем:

- Конкурентоспособные цены и скидки постоянным клиентам.
- Специальные условия для постоянных клиентов.
- Подбор аналогов.
- Поставку компонентов в любых объемах, удовлетворяющих вашим потребностям.
- Приемлемые сроки поставки, возможна ускоренная поставка.
- Доставку товара в любую точку России и стран СНГ.
- Комплексную поставку.
- Работу по проектам и поставку образцов.
- Формирование склада под заказчика.
- Сертификаты соответствия на поставляемую продукцию (по желанию клиента).
- Тестирование поставляемой продукции.
- Поставку компонентов, требующих военную и космическую приемку.
- Входной контроль качества.
- Наличие сертификата ISO.

В составе нашей компании организован Конструкторский отдел, призванный помогать разработчикам, и инженерам.

Конструкторский отдел помогает осуществить:

- Регистрацию проекта у производителя компонентов.
- Техническую поддержку проекта.
- Защиту от снятия компонента с производства.
- Оценку стоимости проекта по компонентам.
- Изготовление тестовой платы монтаж и пусконаладочные работы.



Тел: +7 (812) 336 43 04 (многоканальный)

Email: org@lifeelectronics.ru