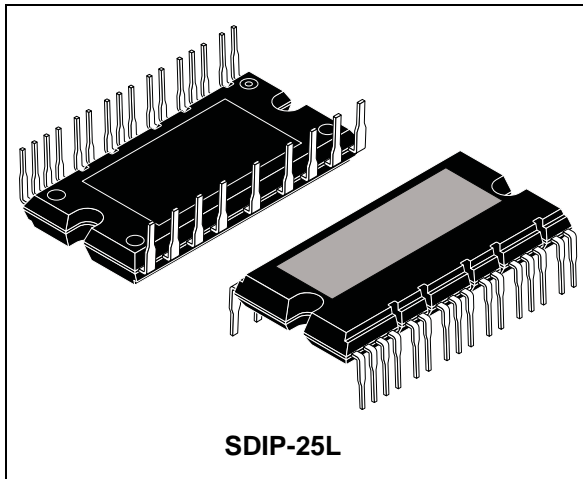


## SLLIMM™ small low-loss intelligent molded module IPM, 3-phase inverter, 10 A, 600 V short-circuit rugged IGBT

Datasheet - production data



### Applications

- 3-phase inverters for motor drives
- Home appliances, such as washing machines, refrigerators, air conditioners

### Description

This intelligent power module provides a compact, high performance AC motor drive in a simple, rugged design. Combining ST proprietary control ICs with the most advanced short-circuit-rugged IGBT system technology, this device is ideal for 3-phase inverters in applications such as home appliances and air conditioners. SLLIMM™ is a trademark of STMicroelectronics.

### Features

- IPM 10 A, 600 V, 3-phase IGBT inverter bridge including control ICs for gate driving and free-wheeling diodes
- Short-circuit rugged IGBT
- $V_{CE(sat)}$  negative temperature coefficient
- 3.3 V, 5 V, 15 V CMOS/TTL inputs comparators with hysteresis and pull-down resistor
- Undervoltage lockout
- Internal bootstrap diode
- Interlocking function
- DBC substrate leading to low thermal resistance
- Isolation rating of 2500  $V_{rms}/min$
- 4.7 k $\Omega$  NTC for temperature control
- UL recognized: UL1557 file E81734

**Table 1. Device summary**

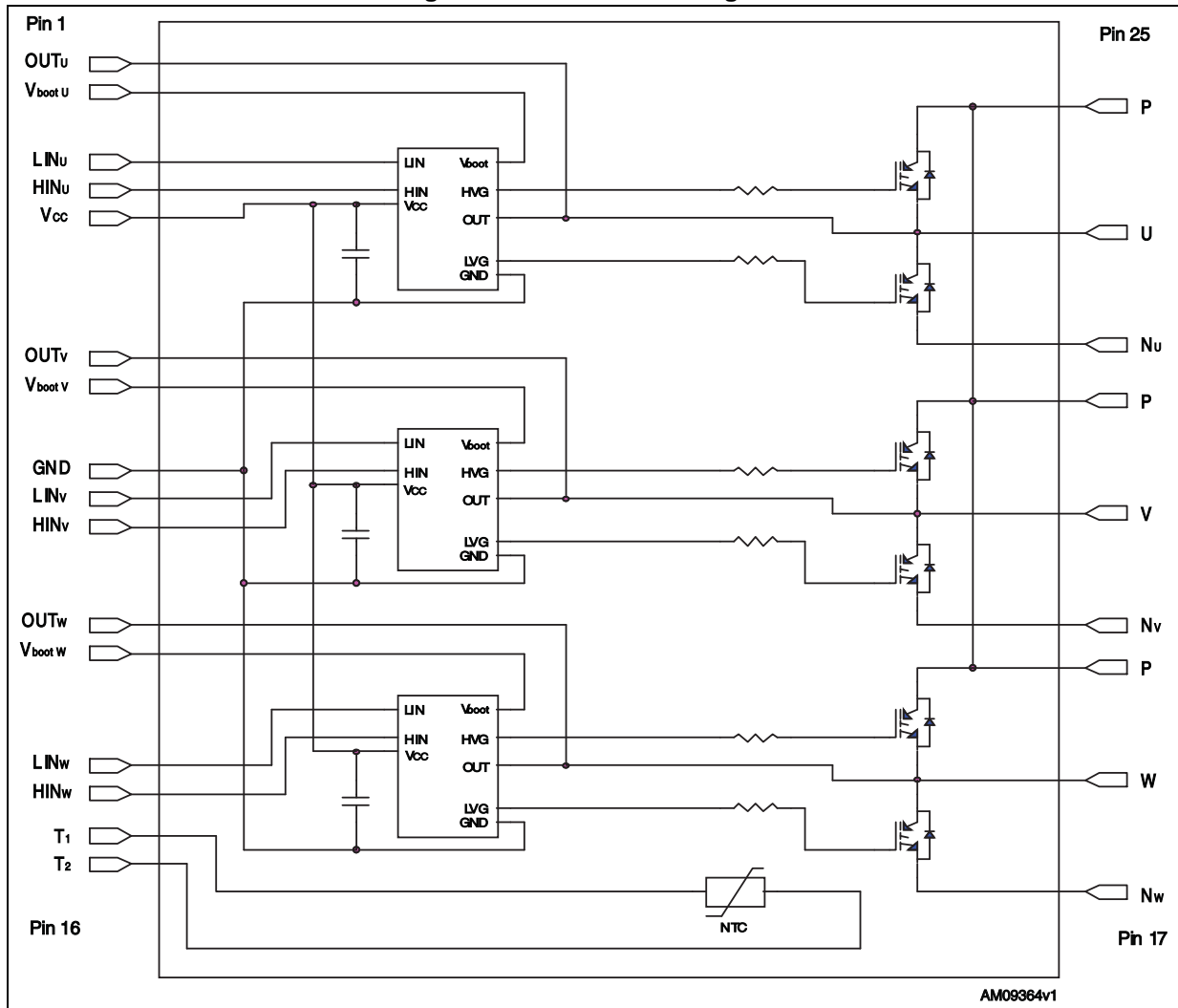
Order code	Marking	Package	Packing
STGIPS10K60A2	GIPS10K60A2	SDIP-25L	Tube

# Contents

- 1 Internal block diagram and pin configuration ..... 3**
- 2 Electrical ratings ..... 5**
  - 2.1 Absolute maximum ratings ..... 5
  - 2.2 Thermal data ..... 6
- 3 Electrical characteristics ..... 7**
  - 3.1 Control part ..... 9
    - 3.1.1 NTC thermistor ..... 9
- 4 Application information ..... 12**
  - 4.1 Recommendations ..... 13
- 5 Package information ..... 14**
  - 5.1 SDIP-25L package information ..... 14
  - 5.2 Packing information ..... 16
- 6 Revision history ..... 17**

# 1 Internal block diagram and pin configuration

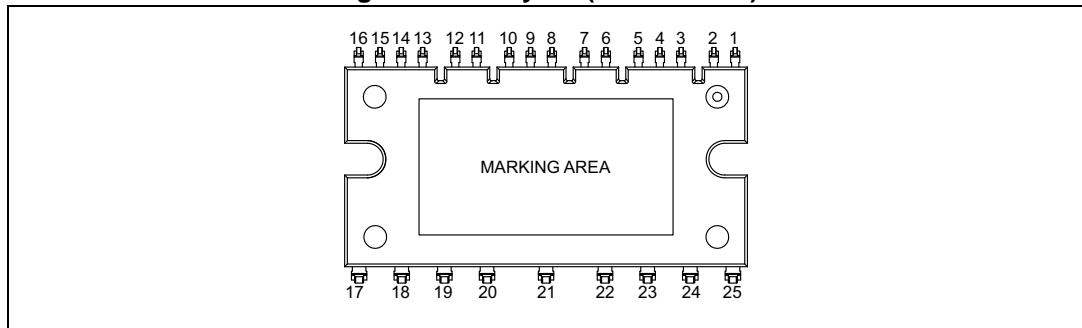
Figure 1. Internal block diagram



**Table 2. Pin description**

Pin	Symbol	Description
1	OUT <sub>U</sub>	High side reference output for U phase
2	V <sub>boot U</sub>	Bootstrap voltage for U phase
3	LIN <sub>U</sub>	Low side logic input for U phase
4	HIN <sub>U</sub>	High side logic input for U phase
5	V <sub>CC</sub>	Low voltage power supply
6	OUT <sub>V</sub>	High side reference output for V phase
7	V <sub>boot V</sub>	Bootstrap voltage for V phase
8	GND	Ground
9	LIN <sub>V</sub>	Low side logic input for V phase
10	HIN <sub>V</sub>	High side logic input for V phase
11	OUT <sub>W</sub>	High side reference output for W phase
12	V <sub>boot W</sub>	Bootstrap voltage for W phase
13	LIN <sub>W</sub>	Low side logic input for W phase
14	HIN <sub>W</sub>	High side logic input for W phase
15	T <sub>1</sub>	NTC thermistor terminal 1
16	T <sub>2</sub>	NTC thermistor terminal 2
17	N <sub>W</sub>	Negative DC input for W phase
18	W	W phase output
19	P	Positive DC input
20	N <sub>V</sub>	Negative DC input for V phase
21	V	V phase output
22	P	Positive DC input
23	N <sub>U</sub>	Negative DC input for U phase
24	U	U phase output
25	P	Positive DC input

**Figure 2. Pin layout (bottom view)**



## 2 Electrical ratings

### 2.1 Absolute maximum ratings

**Table 3. Inverter part**

Symbol	Parameter	Value	Unit
$V_{PN}$	Supply voltage applied between P - $N_U$ , $N_V$ , $N_W$	450	V
$V_{PN(surge)}$	Supply voltage (surge) applied between P - $N_U$ , $N_V$ , $N_W$	500	V
$V_{CES}$	Each IGBT collector emitter voltage ( $V_{IN}^{(1)} = 0$ )	600	V
$\pm I_C^{(2)}$	Each IGBT continuous collector current at $T_C = 25^\circ\text{C}$	10	A
$\pm I_{CP}^{(3)}$	Each IGBT pulsed collector current	20	A
$P_{TOT}$	Each IGBT total dissipation at $T_C = 25^\circ\text{C}$	33	W
$t_{scw}$	Short-circuit withstand time, $V_{CE} = 0.5 V_{(BR)CES}$ $T_j = 125^\circ\text{C}$ , $V_{CC} = V_{boot} = 15\text{ V}$ , $V_{IN(1)} = 5\text{ V}$	5	$\mu\text{s}$

1. Applied between  $HIN_i$ ,  $LIN_i$  and  $G_{ND}$  for  $i = U, V, W$ .
2. Calculated according to the iterative formula:

$$I_C(T_C) = \frac{T_{j(max)} - T_C}{R_{thj-c} \times V_{CE(sat)(max)}(T_{j(max)}, I_C(T_C))}$$

3. Pulse width limited by max junction temperature.

**Table 4. Control part**

Symbol	Parameter	Min.	Max	Unit
$V_{OUT}$	Output voltage applied between $OUT_U$ , $OUT_V$ , $OUT_W$ - GND	$V_{boot} - 18$	$V_{boot} + 0.3$	V
$V_{CC}$	Low voltage power supply	- 0.3	18	V
$V_{boot}$	Bootstrap voltage	- 0.3	618	V
$V_{IN}$	Logic input voltage applied between $HIN_i$ , $LIN_i$ and $G_{ND}$ for $i = U, V, W$	- 0.3	$V_{CC} + 0.3$	V
$dV_{OUT}/dt$	Allowed output slew rate	50	50	V/ns

**Table 5. Total system**

Symbol	Parameter	Value	Unit
$V_{ISO}$	Isolation withstand voltage applied between each pin and heatsink plate (AC voltage, $t = 60\text{ sec.}$ )	2500	V
$T_J$	Power chips operating junction temperature	-40 to 150	$^\circ\text{C}$
$T_C$	Module case operating temperature	-40 to 125	$^\circ\text{C}$

## 2.2 Thermal data

Table 6. Thermal data

Symbol	Parameter	Value	Unit
$R_{thJC}$	Thermal resistance junction-case single IGBT max.	3.8	°C/W
	Thermal resistance junction-case single diode max.	5.5	°C/W

### 3 Electrical characteristics

T<sub>j</sub> = 25°C unless otherwise specified.

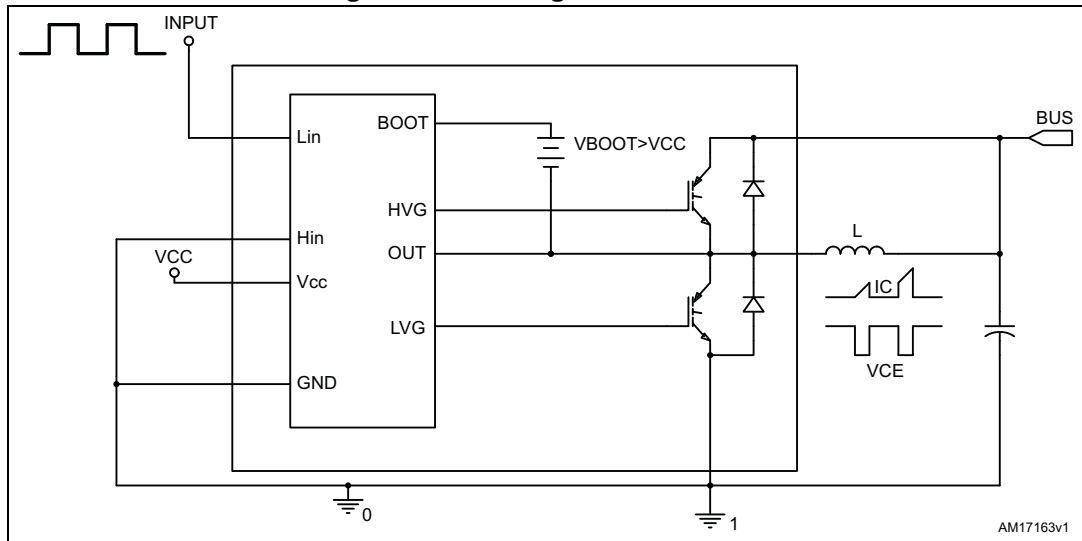
Table 7. Inverter part

Symbol	Parameter	Test conditions	Value			Unit
			Min.	Typ.	Max.	
V <sub>CE(sat)</sub>	Collector-emitter saturation voltage	V <sub>CC</sub> = V <sub>boot</sub> = 15 V, V <sub>IN</sub> <sup>(1)</sup> = 5 V, I <sub>C</sub> = 5 A	-	2.1	2.5	V
		V <sub>CC</sub> = V <sub>boot</sub> = 15 V, V <sub>IN</sub> <sup>(1)</sup> = 5 V, I <sub>C</sub> = 5 A, T <sub>j</sub> = 125 °C	-	1.8		
I <sub>CES</sub>	Collector-cut off current (V <sub>IN</sub> <sup>(1)</sup> = 0 "logic state")	V <sub>CE</sub> = 550 V V <sub>CC</sub> = V <sub>boot</sub> = 15 V	-		150	µA
V <sub>F</sub>	Diode forward voltage	V <sub>IN</sub> <sup>(1)</sup> = 0 "logic state", I <sub>C</sub> = 5 A	-		1.9	V
<b>Inductive load switching time and energy</b>						
t <sub>on</sub>	Turn-on time	V <sub>DD</sub> = 300 V, V <sub>CC</sub> = V <sub>boot</sub> = 15 V, V <sub>IN</sub> <sup>(1)</sup> = 0 ÷ 5 V, I <sub>C</sub> = 5 A (see <a href="#">Figure 4</a> )	-	320	-	ns
t <sub>c(on)</sub>	Crossover time (on)		-	70	-	
t <sub>off</sub>	Turn-off time		-	430	-	
t <sub>c(off)</sub>	Crossover time (off)		-	135	-	
t <sub>rr</sub>	Reverse recovery time		-	130	-	
E <sub>on</sub>	Turn-on switching losses		-	65	-	µJ
E <sub>off</sub>	Turn-off switching losses		-	75	-	

1. Applied between HIN<sub>i</sub>, LIN<sub>i</sub> and G<sub>ND</sub> for i = U, V, W.

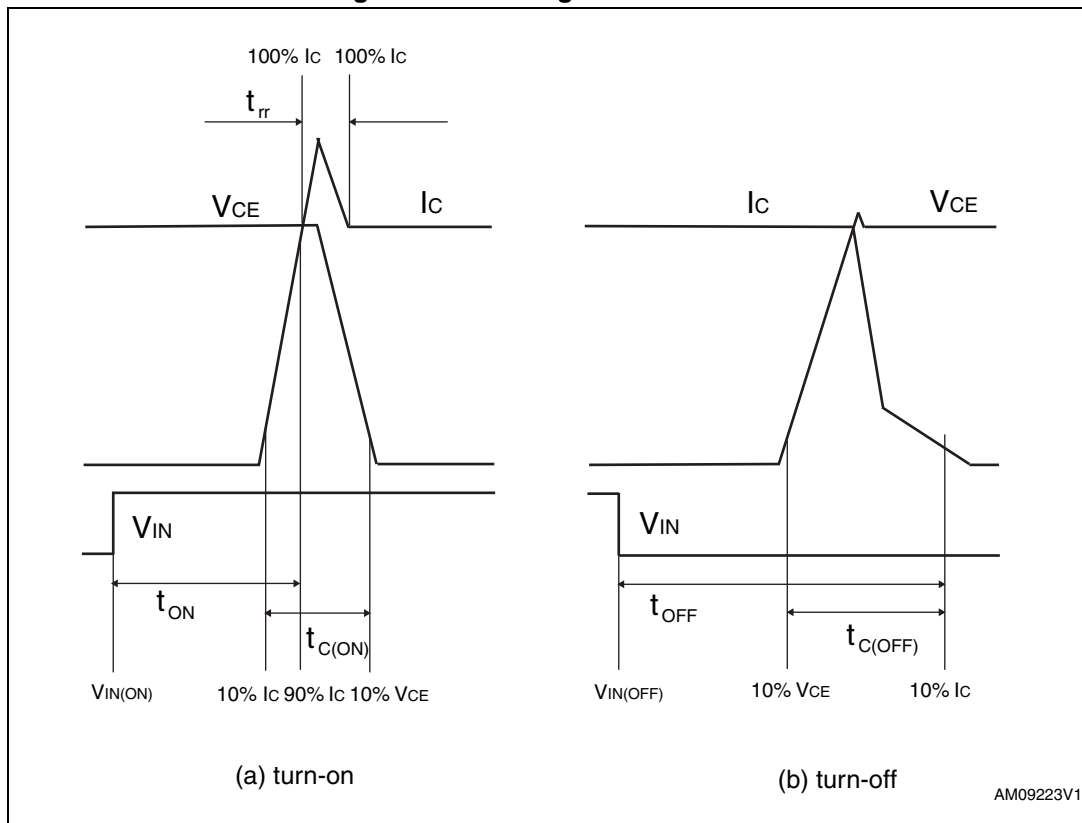
Note: t<sub>ON</sub> and t<sub>OFF</sub> include the propagation delay time of the internal drive. t<sub>C(ON)</sub> and t<sub>C(OFF)</sub> are the switching time of IGBT itself under the internally given gate driving condition.

Figure 3. Switching time test circuit



AM17163v1

Figure 4. Switching time definition



AM09223V1



### 3.1 Control part

**Table 8. Low supply voltage ( $V_{CC} = 15\text{ V}$  unless otherwise specified)**

Symbol	Parameter	Test conditions	Min.	Typ.	Max.	Unit
$V_{CCthON}$	Under voltage turn on threshold		9.1	9.6	10.1	V
$V_{CCthOFF}$	Under voltage turn off threshold		7.9	8.3	8.8	V
$V_{CChys}$	Under voltage hystereses		0.9			V
$I_{qccu}$	Under voltage quiescent supply current	$V_{CC} < 7.9\text{ V}$		0.75	1.2	mA
$I_{qcc}$	Quiescent current	$V_{CC} = 15\text{ V}$		1	1.5	mA

**Table 9. Bootstrap supply ( $V_{CC} = 15\text{ V}$  unless otherwise specified)**

Symbol	Parameter	Test conditions	Min.	Typ.	Max.	Unit
$V_{boot\_thON}$	Under voltage turn on threshold		8.5	9.5	10.5	V
$V_{boot\_thOFF}$	Under voltage turn off threshold		7.2	8.3	9.2	V
$V_{boot_hys}$	Under voltage hystereses		0.9			V
$I_{qboot}$	Quiescent current				250	$\mu\text{A}$
$R_{DS(on)}$	Bootstrap driver on resistance	$V_{CC} > 12.5\text{ V}$		125		$\Omega$

**Table 10. Logic input <sup>(1)</sup> ( $V_{CC} = 15\text{ V}$  unless otherwise specified)**

Symbol	Parameter	Test conditions	Min.	Typ.	Max.	Unit
$V_{il}$	Low level logic input voltage				1.1	V
$V_{ih}$	High level logic input voltage		1.8			V
$I_{il}$	Low level logic input current	$V_{IN}^{(2)} = 0$	-1			$\mu\text{A}$
$I_{ih}$	High level logic input current	$V_{IN}^{(1)} = 15\text{ V}$		20	70	$\mu\text{A}$

1. See [Figure 9: Dead time and interlocking definition](#).
2. Applied between  $HIN_i$ ,  $LIN_i$  and  $G_{ND}$  for  $i = U, V, W$

#### 3.1.1 NTC thermistor

**Table 11. NTC thermistor**

Symbol	Parameter	Test conditions	Min.	Typ.	Max.	Unit.
$R_{25}$	Resistance	$T = 25^\circ\text{C}$		4.7		$\text{k}\Omega$
$R_{125}$	Resistance	$T = 125^\circ\text{C}$		160		$\Omega$
B	B-constant	$T = 25^\circ\text{C}$ to $85^\circ\text{C}$		3950		K
T	Operating temperature		-40		150	$^\circ\text{C}$

Equation 1: resistance variation vs. temperature

$$R(T) = R_{25} \cdot e^{B \left( \frac{1}{T} - \frac{1}{298} \right)}$$

Where T are temperatures in Kelvin.

Figure 5. NTC resistance vs. temperature

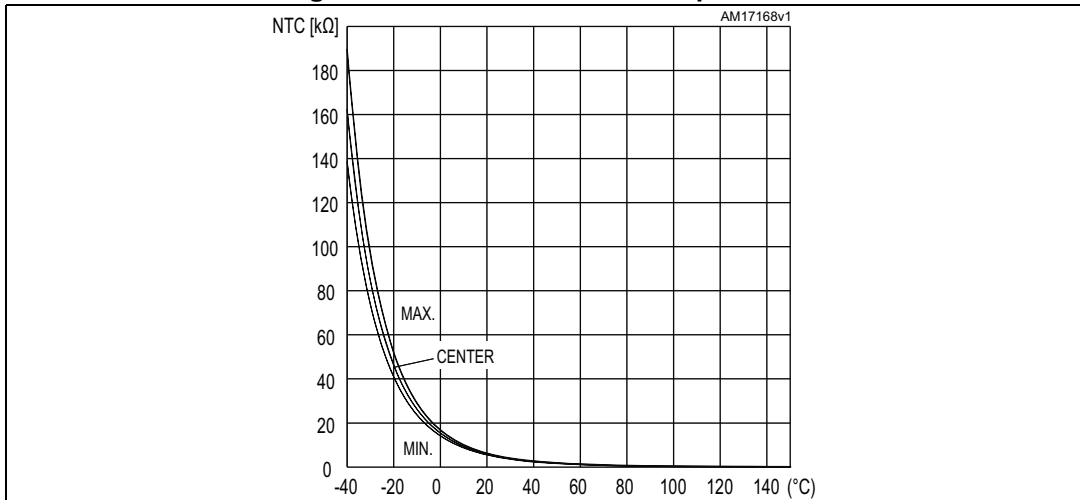
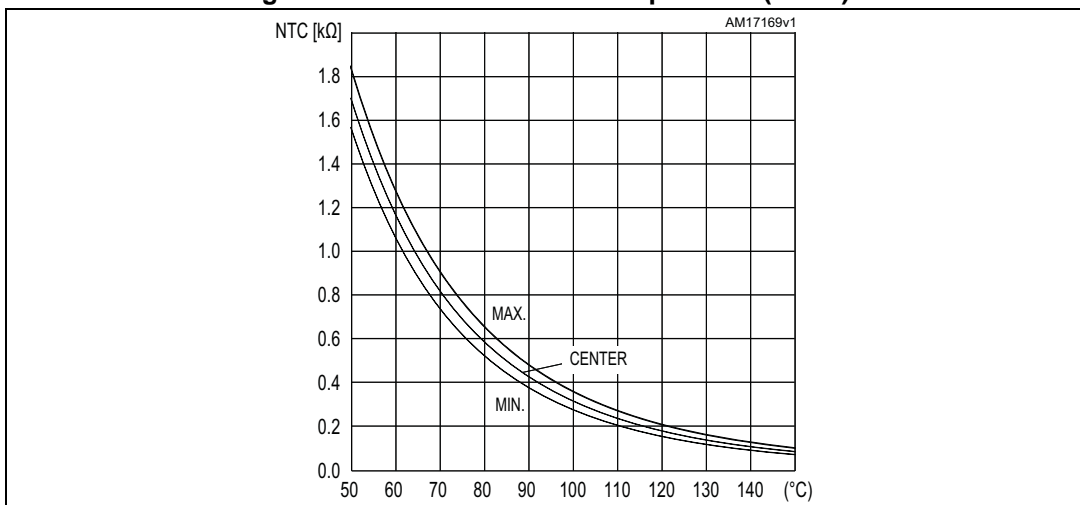
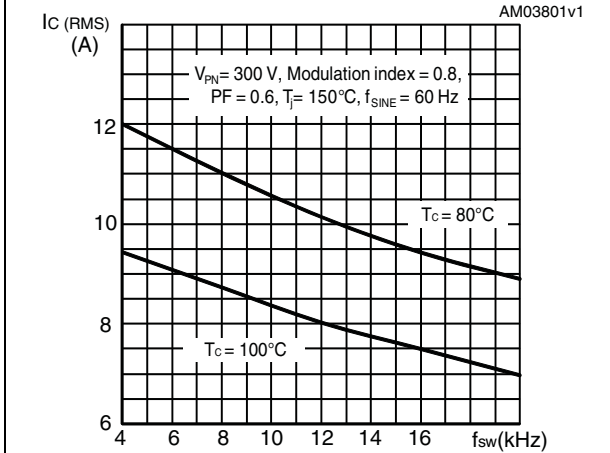


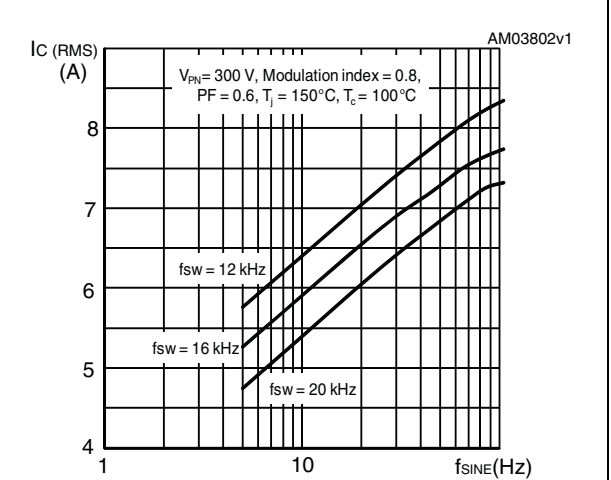
Figure 6. NTC resistance vs. temperature (zoom)



**Figure 7. Maximum  $I_{C(RMS)}$  current vs. switching frequency (1)**

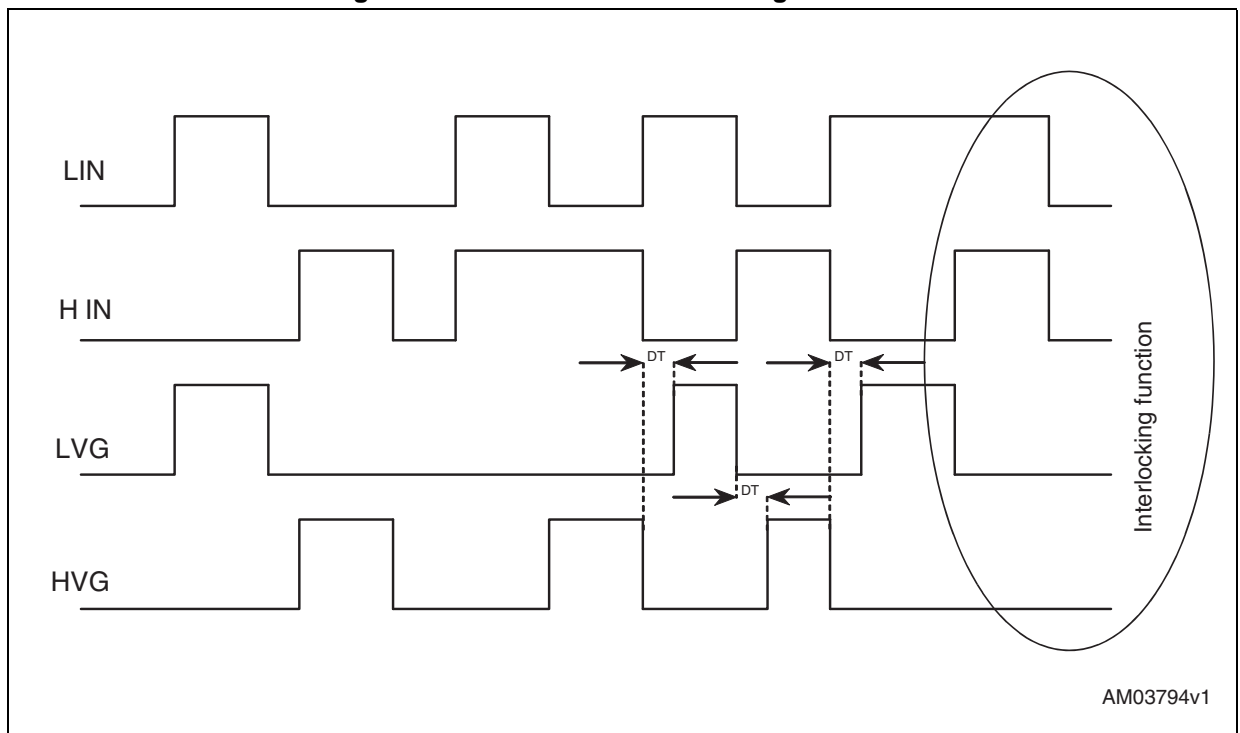


**Figure 8. Maximum  $I_{C(RMS)}$  current vs.  $f_{SINE}$  (1)**



1. Simulated curves refer to typical IGBT parameters and maximum  $R_{thj-c}$ .

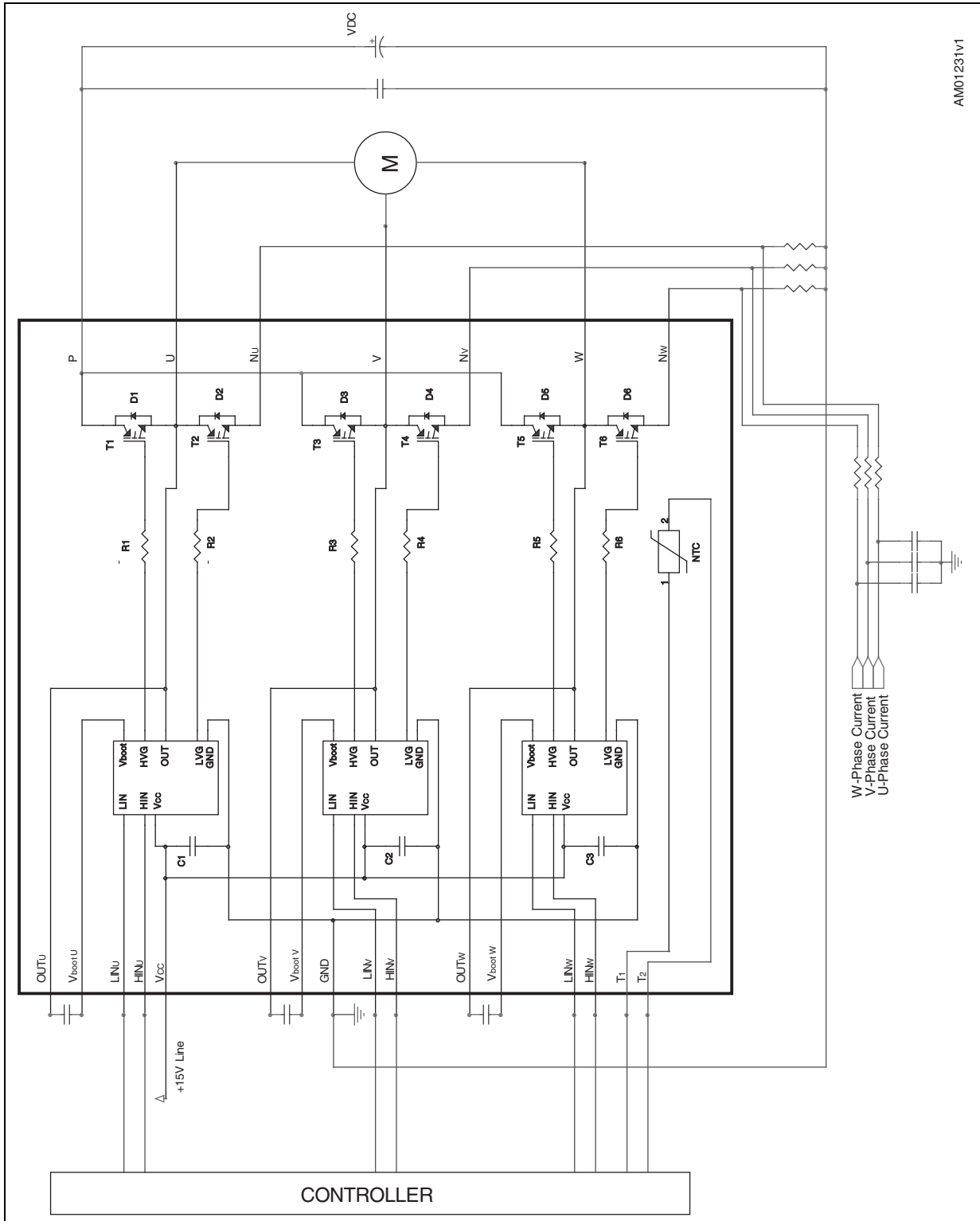
**Figure 9. Dead time and interlocking definition**



Minimum recommended dead time (DT) between low and high side logic input: 1  $\mu\text{s}$ .

# 4 Application information

Figure 10. Typical application circuit



## 4.1 Recommendations

- Input signal HIN,LIN are active-high logic. A 500 k $\Omega$  (typ.) pull down resistor is built-in for each high side input. If an external RC filter is used, for noise immunity, pay attention to the variation of the input signal level.
- To prevent the input signals oscillation, the wiring of each input should be as short as possible.
- By integrating an application specific type HVIC inside the module, direct coupling to MCU terminals without any opto-coupler is possible.
- Each capacitor should be located as nearby the pins of IPM as possible.
- Low inductance shunt resistors should be used for phase leg current sensing.
- Electrolytic bus capacitors should be mounted as close to the module bus terminals as possible. Additional high frequency ceramic capacitor mounted close to the module pins will further improve performance.

**Table 12. Recommended operating conditions**

Symbol	Parameter	Conditions	Min.	Typ.	Max.	Unit
$V_{PN}$	Supply Voltage	Applied between P-Nu, Nv, Nw		300	400	V
$V_{CC}$	Control supply voltage	Applied between $V_{CC}$ -GND	12	15	17	V
$V_{BS}$	High side bias voltage	Applied between $V_{BOOTi}$ - $OUT_i$ for $i = U, V, W$	11.5		17	V
$t_{dead}$	Blanking time to prevent Arm-short	For each input signal	1			$\mu$ s
$f_{PWM}$	PWM input signal	-40°C < $T_c$ < 100°C -40°C < $T_j$ < 125°C			20	kHz
$T_c$	Case operation temperature				100	°C

For further details, refer to AN3338.

## 5 Package information

In order to meet environmental requirements, ST offers these devices in different grades of ECOPACK® packages, depending on their level of environmental compliance. ECOPACK® specifications, grade definitions and product status are available at: [www.st.com](http://www.st.com). ECOPACK is an ST trademark.

Please refer to dedicated technical note TN0107 for mounting instructions.

### 5.1 SDIP-25L package information

Figure 11. SDIP-25L package outline

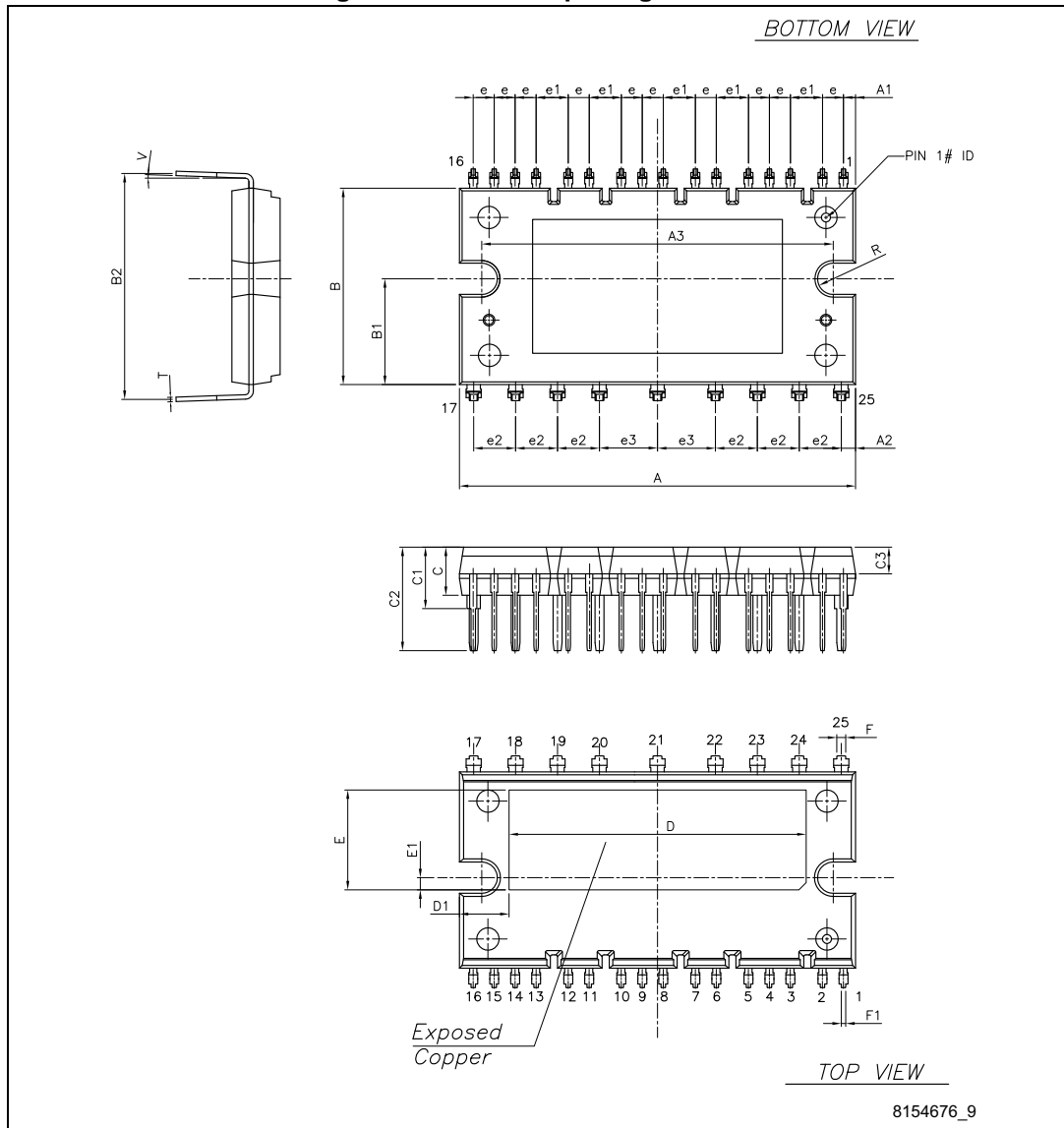
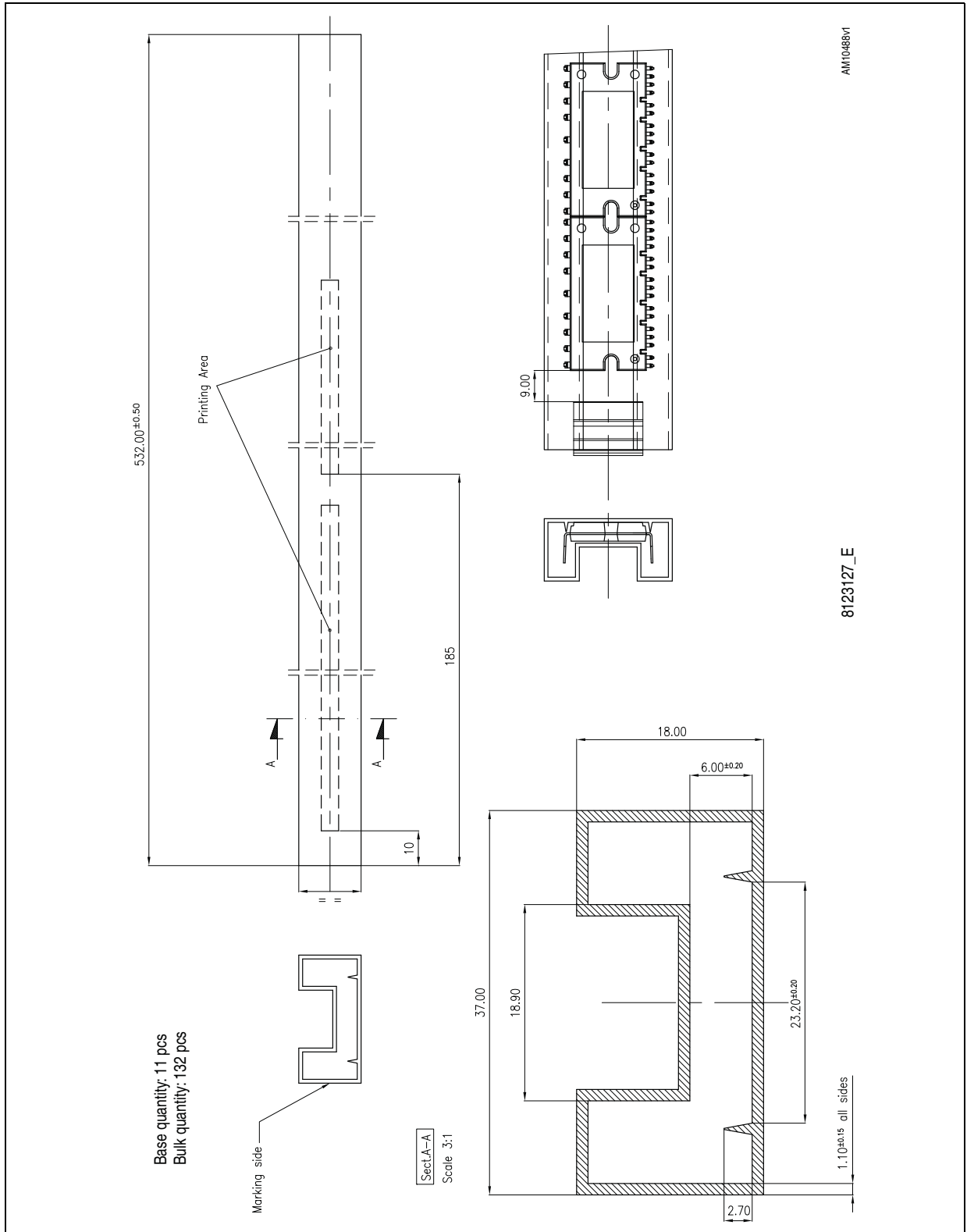


Table 13. SDIP-25L mechanical data

Dim.	mm		
	Min.	Typ.	Max.
A	43.90	44.40	44.90
A1	1.15	1.35	1.55
A2	1.40	1.60	1.80
A3	38.90	39.40	39.90
B	21.50	22.00	22.50
B1	11.25	11.85	12.45
B2	24.83	25.23	25.63
C	5.00	5.40	6.00
C1	6.50	7.00	7.50
C2	11.20	11.70	12.20
C3	2.90	3.00	3.10
e	2.15	2.35	2.55
e1	3.40	3.60	3.80
e2	4.50	4.70	4.90
e3	6.30	6.50	6.70
D		33.30	
D1		5.55	
E		11.20	
E1		1.40	
F	0.85	1.00	1.15
F1	0.35	0.50	0.65
R	1.55	1.75	1.95
T	0.45	0.55	0.65
V	0°		6°

## 5.2 Packing information

Figure 12. SDIP-25L packing information





## 6 Revision history

**Table 14. Document revision history**

Date	Revision	Changes
09-Dec-2013	1	Initial release.
18-Feb-2014	2	– Document status promoted from target specification to preliminary data – Minor text changes
14-Apr-2015	3	Text edits and formatting changes throughout document Updated <a href="#">Figure 2: Pin layout (bottom view)</a> Updated <a href="#">Section 5: Package information</a>

**IMPORTANT NOTICE – PLEASE READ CAREFULLY**

STMicroelectronics NV and its subsidiaries ("ST") reserve the right to make changes, corrections, enhancements, modifications, and improvements to ST products and/or to this document at any time without notice. Purchasers should obtain the latest relevant information on ST products before placing orders. ST products are sold pursuant to ST's terms and conditions of sale in place at the time of order acknowledgement.

Purchasers are solely responsible for the choice, selection, and use of ST products and ST assumes no liability for application assistance or the design of Purchasers' products.

No license, express or implied, to any intellectual property right is granted by ST herein.

Resale of ST products with provisions different from the information set forth herein shall void any warranty granted by ST for such product.

ST and the ST logo are trademarks of ST. All other product or service names are the property of their respective owners.

Information in this document supersedes and replaces information previously supplied in any prior versions of this document.

© 2015 STMicroelectronics – All rights reserved

Компания «Life Electronics» занимается поставками электронных компонентов импортного и отечественного производства от производителей и со складов крупных дистрибьюторов Европы, Америки и Азии.

С конца 2013 года компания активно расширяет линейку поставок компонентов по направлению коаксиальный кабель, кварцевые генераторы и конденсаторы (керамические, пленочные, электролитические), за счёт заключения дистрибьюторских договоров

Мы предлагаем:

- Конкурентоспособные цены и скидки постоянным клиентам.
- Специальные условия для постоянных клиентов.
- Подбор аналогов.
- Поставку компонентов в любых объемах, удовлетворяющих вашим потребностям.
- Приемлемые сроки поставки, возможна ускоренная поставка.
- Доставку товара в любую точку России и стран СНГ.
- Комплексную поставку.
- Работу по проектам и поставку образцов.
- Формирование склада под заказчика.
- Сертификаты соответствия на поставляемую продукцию (по желанию клиента).
- Тестирование поставляемой продукции.
- Поставку компонентов, требующих военную и космическую приемку.
- Входной контроль качества.
- Наличие сертификата ISO.

В составе нашей компании организован Конструкторский отдел, призванный помогать разработчикам, и инженерам.

Конструкторский отдел помогает осуществить:

- Регистрацию проекта у производителя компонентов.
- Техническую поддержку проекта.
- Защиту от снятия компонента с производства.
- Оценку стоимости проекта по компонентам.
- Изготовление тестовой платы монтаж и пусконаладочные работы.



Тел: +7 (812) 336 43 04 (многоканальный)

Email: [org@lifeelectronics.ru](mailto:org@lifeelectronics.ru)