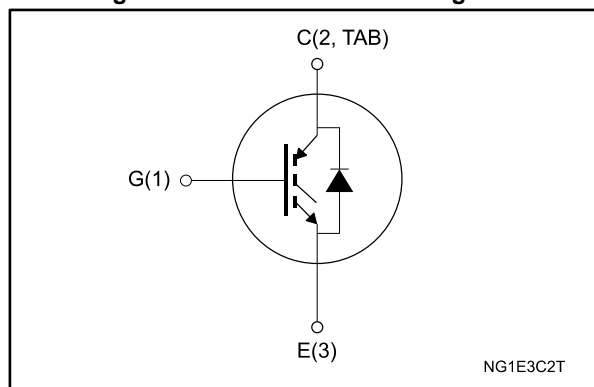

Figure 1: Internal schematic diagram



Features

- Low on voltage drop ($V_{CE(sat)}$)
- Low C_{RES} / C_{IES} ratio (no cross-conduction susceptibility)
- Short-circuit withstand time 10 μ s
- IGBT co-packaged with ultrafast free-wheeling diode

Applications

- High frequency inverters
- Motor drives

Description

These devices are very fast IGBTs developed using advanced PowerMESH™ technology. This process guarantees an excellent trade-off between switching performance and low on-state behavior.

Table 1: Device summary

Order code	Marking	Package	Packing
STGB19NC60KDT4	GB19NC60KD	D ² PAK	Tape and reel
STGF19NC60KD	GF19NC60KD	TO-220FP	Tube
STGP19NC60KD	GP19NC60KD	TO-220	

Contents

1 Electrical ratings 3

2 Electrical characteristics 4

 2.1 Electrical characteristics (curves) 7

3 Test circuits 10

4 Package information 11

 4.1 D²PAK (TO-263) type A package information 11

 4.2 D²PAK (TO-263) type B package information 14

 4.3 D²PAK type A packing information 17

 4.4 D²PAK type B packing information 19

 4.5 TO-220FP package information 21

 4.6 TO-220 type A package information 23

5 Revision history 25

1 Electrical ratings

Table 2: Absolute maximum ratings

Symbol	Parameter	Value		Unit
		D ² PAK, TO-220	TO-220FP	
V _{CEs}	Collector-emitter voltage (V _{GE} = 0 V)	600		V
I _C ⁽¹⁾	Continuous collector current at T _C = 25 °C	35	16	A
	Continuous collector current at T _C = 100 °C	20	10	A
I _{CL} ⁽²⁾	Turn-off latching current	75		A
I _{CP} ⁽³⁾	Pulsed collector current	75		A
V _{GE}	Gate-emitter voltage	±20		V
I _F	Diode RMS forward current at T _C = 25 °C	20		A
I _{FSM}	Surge non repetitive forward current t _p = 10 ms sinusoidal	50		A
P _{TOT}	Total dissipation at T _C = 25 °C	125	32	W
V _{ISO}	Insulation withstand voltage (RMS) from all three leads to external heat-sink (t = 1 s; T _C = 25 °C)		2500	V
t _{scw}	Short-circuit withstand time V _{CE} = 300 V, T _J = 125 °C, R _G = 10 Ω, V _{GE} = 12 V	10		µs
T _{stg}	Storage temperature range	- 55 to 150		°C
T _J	Operating junction temperature range			

Notes:

⁽¹⁾Calculated according to the iterative formula:

$$I_C(T_C) = \frac{T_{J(max)} - T_C}{R_{thj-c} \times V_{CE(sat)(max)}(T_{J(max)}, I_C(T_C))}$$

⁽²⁾V_{clamp} = 80 % V_{CEs}, V_{GE} = 15 V, R_G = 10 Ω, T_J = 150 °C.

⁽³⁾Pulse width limited by maximum junction temperature.

Table 3: Thermal data

Symbol	Parameter	Value		Unit
		D ² PAK, TO-220	TO-220FP	
R _{thj-case}	Thermal resistance junction-case IGBT	1	3.9	°C/W
R _{thj-case}	Thermal resistance junction-case diode	3	5.6	
R _{thj-amb}	Thermal resistance junction-ambient	62.5		

2 Electrical characteristics

T_C = 25 °C unless otherwise specified

Table 4: Static characteristics

Symbol	Parameter	Test conditions	Min.	Typ.	Max.	Unit
V _{(BR)CES}	Collector-emitter breakdown voltage	I _C = 1 mA, V _{GE} = 0 V	600			V
V _{CE(sat)}	Collector-emitter saturation voltage	V _{GE} = 15 V, I _C = 12 A		2.0	2.75	V
		V _{GE} = 15 V, I _C = 12 A, T _C = 125 °C		1.65		
V _{GE(th)}	Gate threshold voltage	V _{CE} = V _{GE} , I _C = 250 μA	4.5		6.5	V
I _{CES}	Collector cut-off current	V _{CE} = 600 V, V _{GE} = 0 V			150	μA
		V _{CE} = 600 V, V _{GE} = 0 V, T _C = 125 °C ⁽¹⁾			1	mA
I _{GES}	Gate-emitter leakage current	V _{CE} = 0 V, V _{GE} = ±20 V			±100	nA

Notes:

⁽¹⁾Defined by design, not subject to production test.

Table 5: Dynamic characteristics

Symbol	Parameter	Test conditions	Min.	Typ.	Max.	Unit
C _{ies}	Input capacitance	V _{CE} = 25 V, f = 1 MHz, V _{GE} = 0 V	-	1170	-	pF
C _{oes}	Output capacitance		-	127	-	
C _{res}	Reverse transfer capacitance		-	28	-	
Q _g	Total gate charge	V _{CE} = 480 V, I _C = 12 A, V _{GE} = 0 to 15 V (see Figure 20: "Gate charge test circuit")	-	55	-	nC
Q _{ge}	Gate-emitter charge		-	11	-	
Q _{gc}	Gate-collector charge		-	26	-	

Table 6: Switching on/off (inductive load)

Symbol	Parameter	Test conditions	Min.	Typ.	Max.	Unit
$t_{d(on)}$	Turn-on delay time	$V_{CC} = 480\text{ V}$, $I_C = 12\text{ A}$, $R_G = 10\ \Omega$, $V_{GE} = 15\text{ V}$ (see <i>Figure 19: "Test circuit for inductive load switching"</i> and <i>Figure 21: "Switching waveform"</i>)	-	30	-	ns
t_r	Current rise time		-	8	-	ns
$(di/dt)_{on}$	Turn-on current slope		-	1450	-	A/ μ s
$t_{d(on)}$	Turn-on delay time	$V_{CC} = 480\text{ V}$, $I_C = 12\text{ A}$, $R_G = 10\ \Omega$, $V_{GE} = 15\text{ V}$, $T_C = 125\text{ }^\circ\text{C}$ (see <i>Figure 19: "Test circuit for inductive load switching"</i> and <i>Figure 21: "Switching waveform"</i>)	-	30	-	ns
t_r	Current rise time		-	8	-	ns
$(di/dt)_{on}$	Turn-on current slope		-	1380	-	A/ μ s
$t_{r(Voff)}$	Off voltage rise time	$V_{CC} = 480\text{ V}$, $I_C = 12\text{ A}$, $R_G = 10\ \Omega$, $V_{GE} = 15\text{ V}$ (see <i>Figure 19: "Test circuit for inductive load switching"</i> and <i>Figure 21: "Switching waveform"</i>)	-	35	-	ns
$t_{d(off)}$	Turn-off delay time		-	105	-	ns
t_f	Current fall time		-	85	-	ns
$t_{r(Voff)}$	Off voltage rise time	$V_{CC} = 480\text{ V}$, $I_C = 12\text{ A}$, $R_G = 10\ \Omega$, $V_{GE} = 15\text{ V}$, $T_C = 125\text{ }^\circ\text{C}$ (see <i>Figure 19: "Test circuit for inductive load switching"</i> and <i>Figure 21: "Switching waveform"</i>)	-	65	-	ns
$t_{d(off)}$	Turn-off delay time		-	145	-	ns
t_f	Current fall time		-	125	-	ns

Table 7: Switching energy (inductive load)

Symbol	Parameter	Test conditions	Min.	Typ.	Max.	Unit
$E_{on(1)}$	Turn-on switching energy	$V_{CC} = 480\text{ V}$, $I_C = 12\text{ A}$, $R_G = 10\ \Omega$, $V_{GE} = 15\text{ V}$ (see <i>Figure 19: "Test circuit for inductive load switching"</i>)	-	165	-	μ J
$E_{off(2)}$	Turn-off switching energy		-	255	-	μ J
E_{ts}	Total switching energy		-	420	-	μ J
$E_{on(1)}$	Turn-on switching energy	$V_{CC} = 480\text{ V}$, $I_C = 12\text{ A}$, $R_G = 10\ \Omega$, $V_{GE} = 15\text{ V}$, $T_C = 125\text{ }^\circ\text{C}$ (see <i>Figure 19: "Test circuit for inductive load switching"</i>)	-	250	-	μ J
$E_{off(2)}$	Turn-off switching energy		-	445	-	μ J
E_{ts}	Total switching energy		-	695	-	μ J

Notes:

- (1) Including the reverse recovery of the diode.
- (2) Including the tail of the collector current.

Table 8: Collector-emitter diode

Symbol	Parameter	Test conditions	Min.	Typ.	Max.	Unit
V _F	Forward on-voltage	I _F =12 A	-	1.9	-	V
		I _F =12 A, T _C =125 °C	-	1.6	-	V
t _{rr}	Reverse recovery time	I _F =12 A, V _R =40 V, di/dt=100 A/μs (see Figure 22: "Diode reverse recovery waveform")	-	31	-	ns
Q _{rr}	Reverse recovery charge		-	30	-	nC
I _{rrm}	Reverse recovery current		-	2	-	A
t _{rr}	Reverse recovery time	I _F =12 A, V _R =40 V, T _C =125 °C, di/dt=100 A/μs (see Figure 22: "Diode reverse recovery waveform")	-	50	-	ns
Q _{rr}	Reverse recovery charge		-	70	-	nC
I _{rrm}	Reverse recovery current		-	4	-	A

2.1 Electrical characteristics (curves)

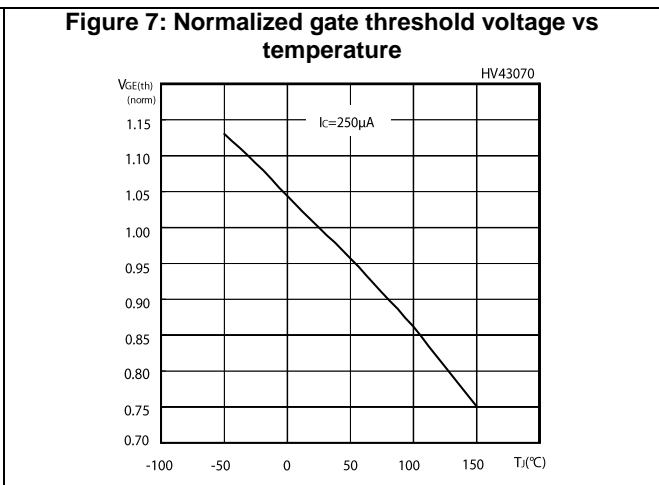
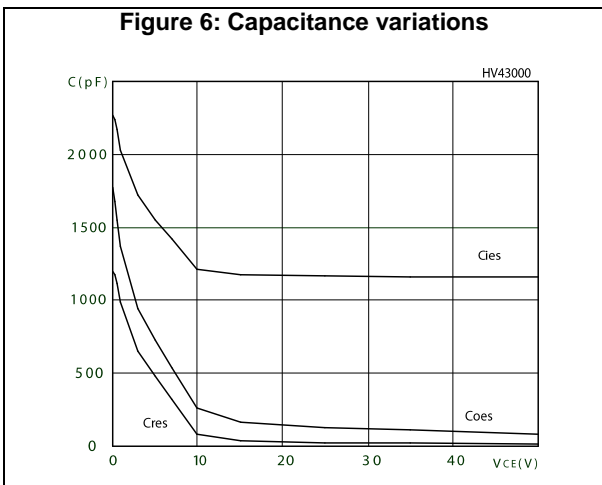
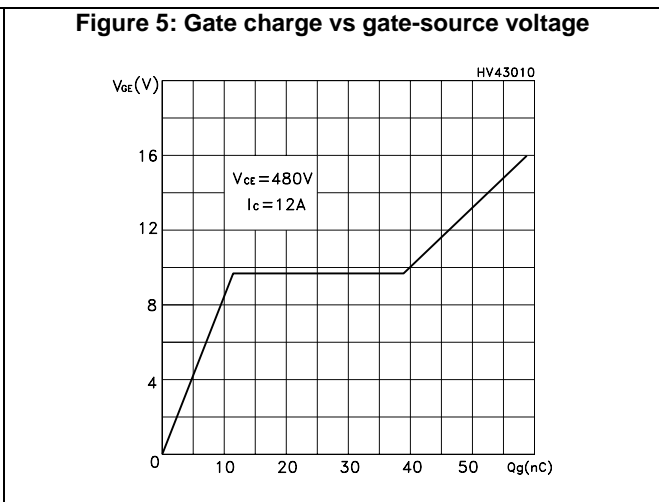
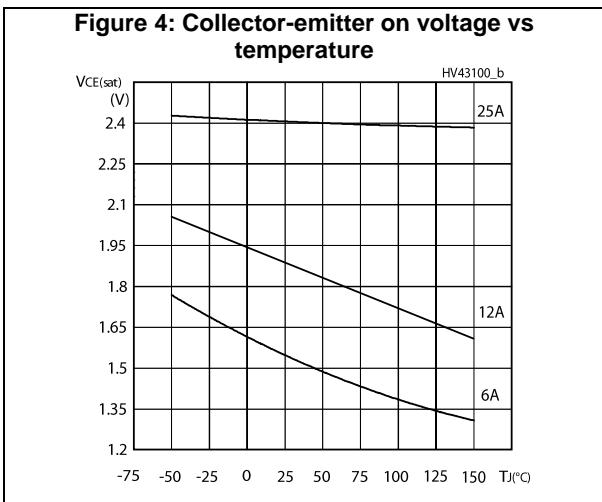
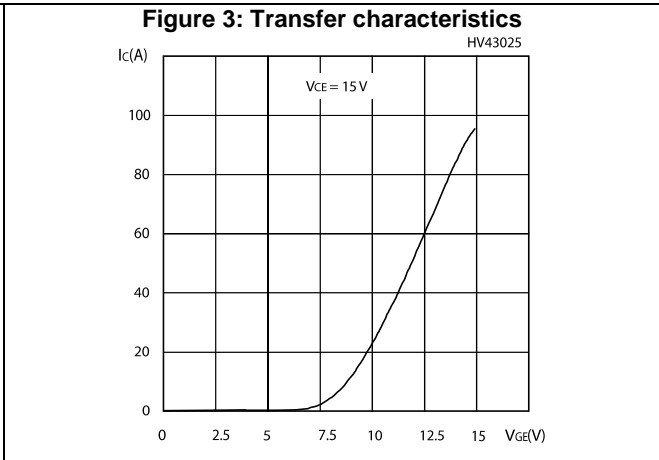
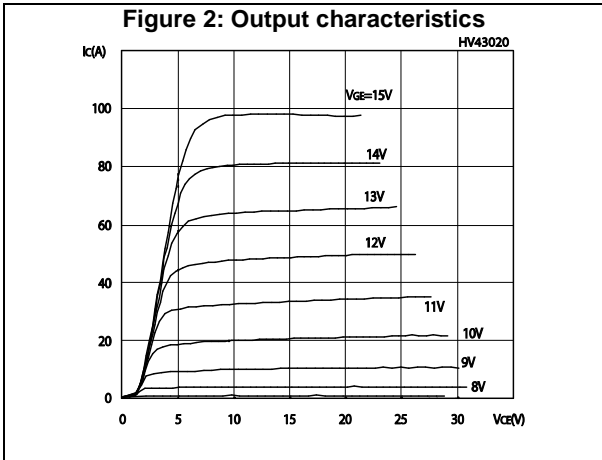

Figure 8: Collector-emitter on voltage vs collector current

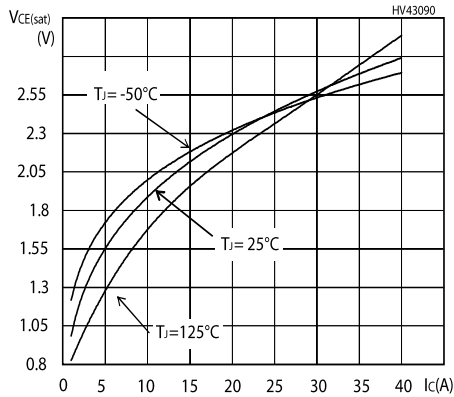

Figure 9: Normalized breakdown voltage vs temperature

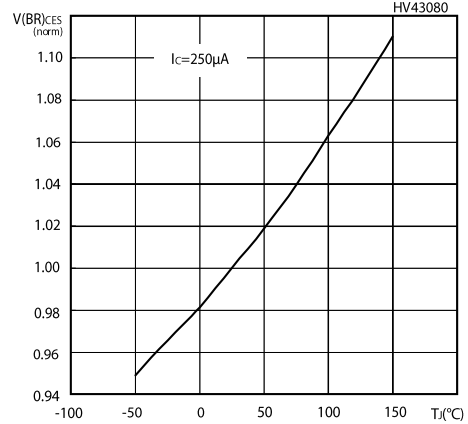

Figure 10: Switching energy vs temperature

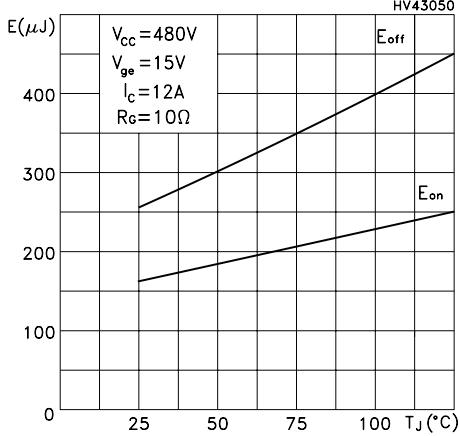

Figure 11: Switching energy vs. gate resistance

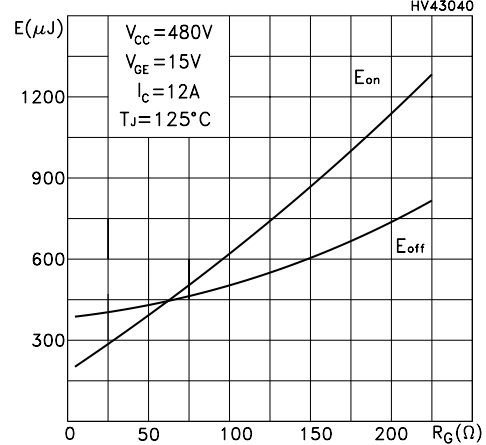

Figure 12: Switching energy vs collector current

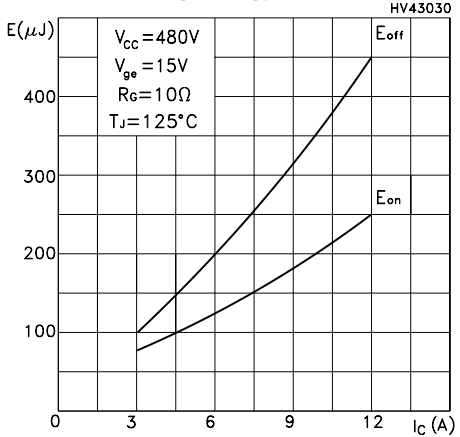

Figure 13: Turn-off SOA

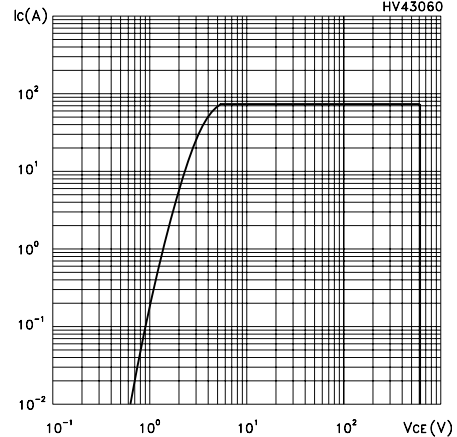

Figure 14: Emitter-collector diode characteristics

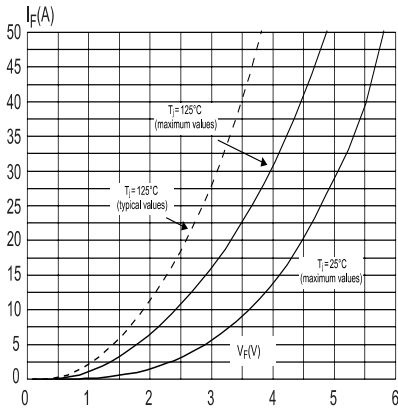

Figure 15: Thermal impedance for TO-220, D²PAK

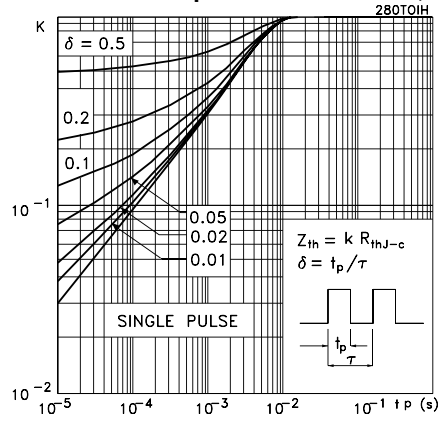

Figure 16: Thermal impedance for TO-220FP

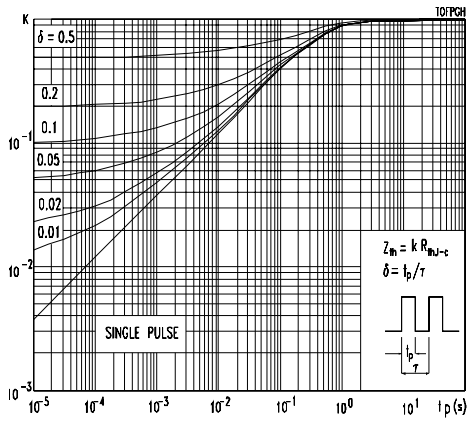

Figure 17: Maximum DC collector current vs T_{CASE} for TO-220FP

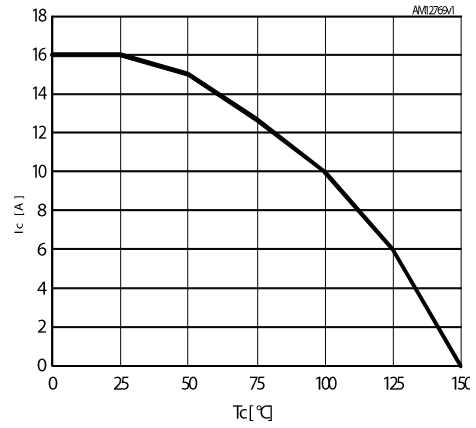
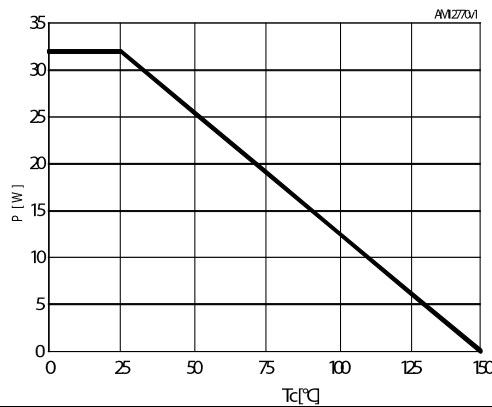
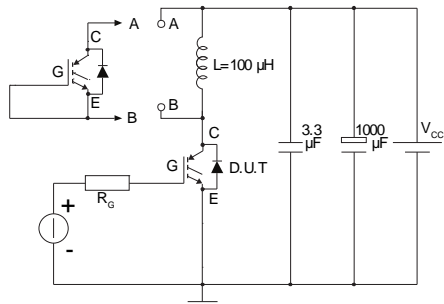

Figure 18: Maximum power dissipation vs T_{CASE} for TO-220FP



3 Test circuits

Figure 19: Test circuit for inductive load switching



AM01504v1

Figure 20: Gate charge test circuit

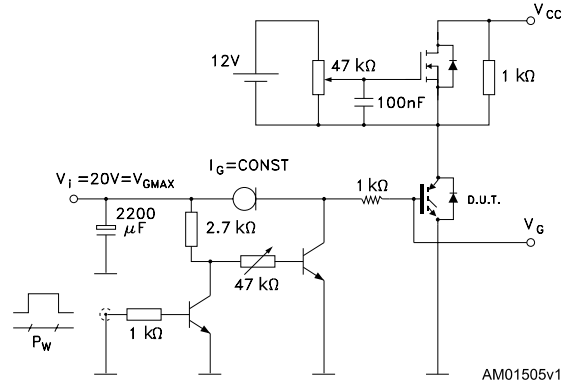

AM01505v1

Figure 21: Switching waveform

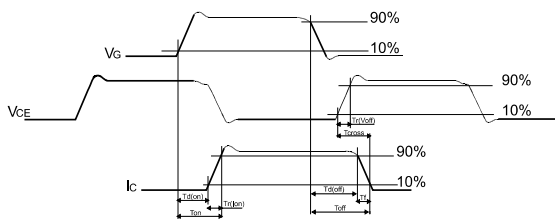

AM01506v1

Figure 22: Diode reverse recovery waveform

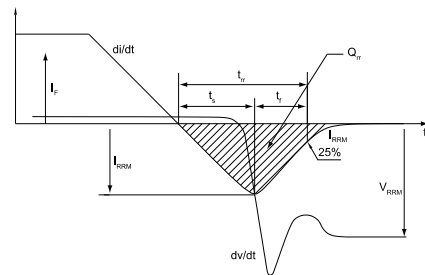

AM01507v1

4 Package information

In order to meet environmental requirements, ST offers these devices in different grades of ECOPACK® packages, depending on their level of environmental compliance. ECOPACK® specifications, grade definitions and product status are available at: www.st.com. ECOPACK® is an ST trademark.

4.1 D²PAK (TO-263) type A package information

Figure 23: D²PAK (TO-263) type A package outline



Table 9: D²PAK (TO-263) type A package mechanical data

Dim.	mm		
	Min.	Typ.	Max.
A	4.40		4.60
A1	0.03		0.23
b	0.70		0.93
b2	1.14		1.70
c	0.45		0.60
c2	1.23		1.36
D	8.95		9.35
D1	7.50	7.75	8.00
D2	1.10	1.30	1.50
E	10.00		10.40
E1	8.50	8.70	8.90
E2	6.85	7.05	7.25
e		2.54	
e1	4.88		5.28
H	15.00		15.85
J1	2.49		2.69
L	2.29		2.79
L1	1.27		1.40
L2	1.30		1.75
R		0.40	
V2	0°		8°

Figure 24: D²PAK (TO-263) type A recommended footprint (dimensions are in mm)

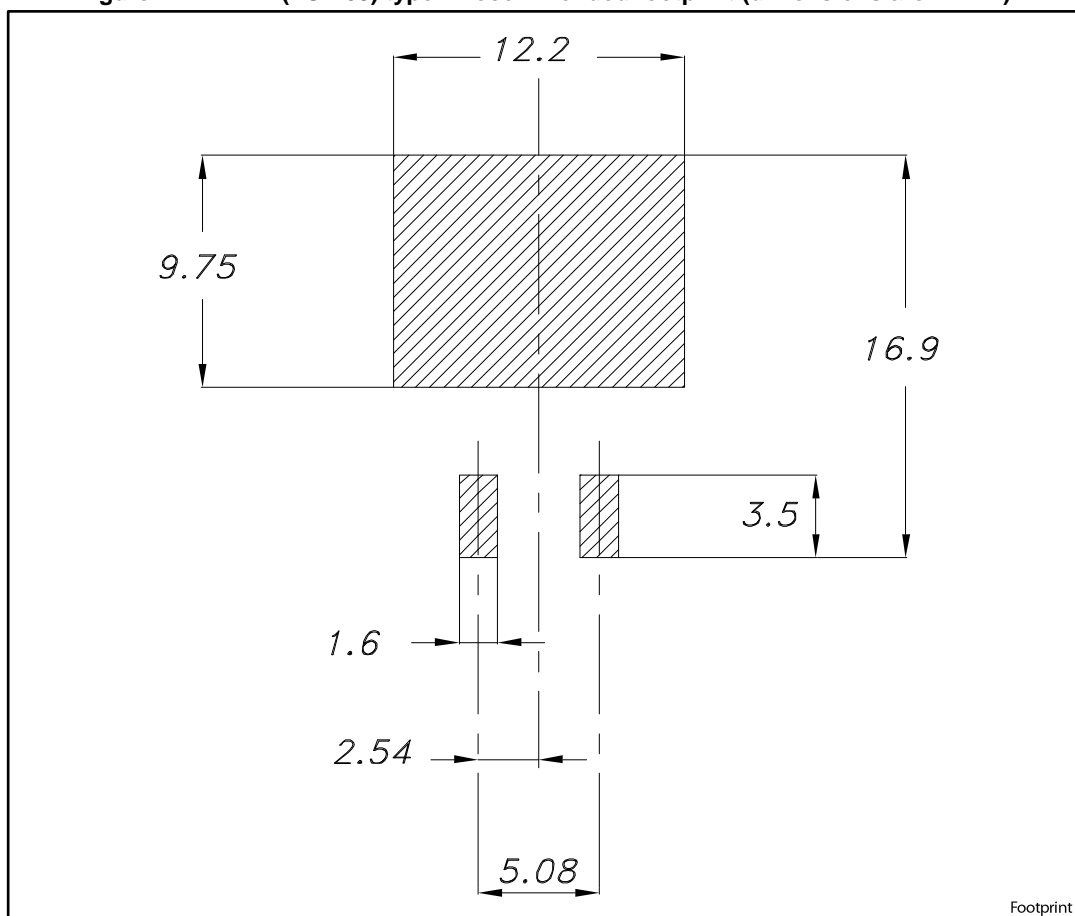

4.2 D²PAK (TO-263) type B package information

Figure 25: D²PAK (TO-263) type B package outline

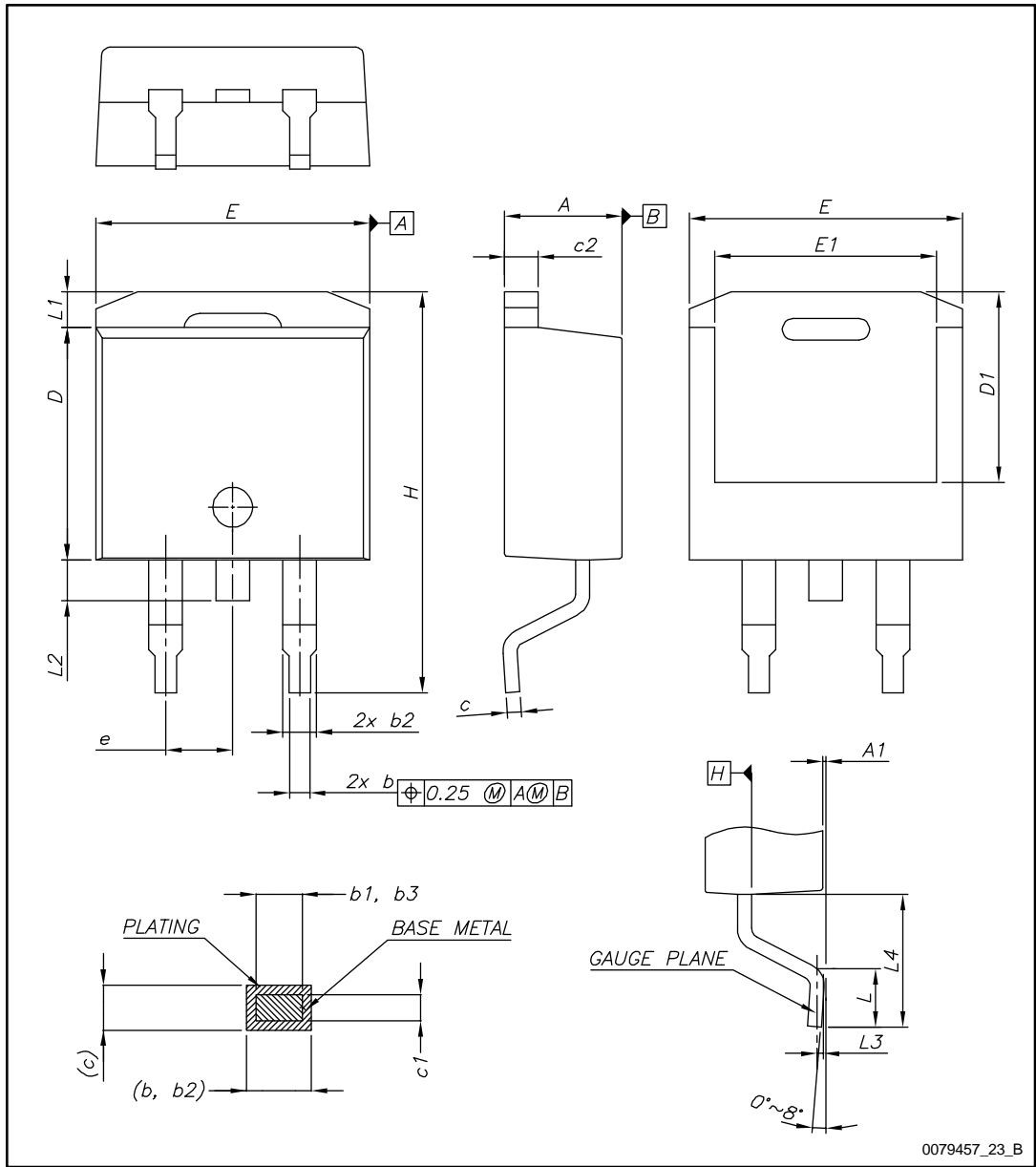
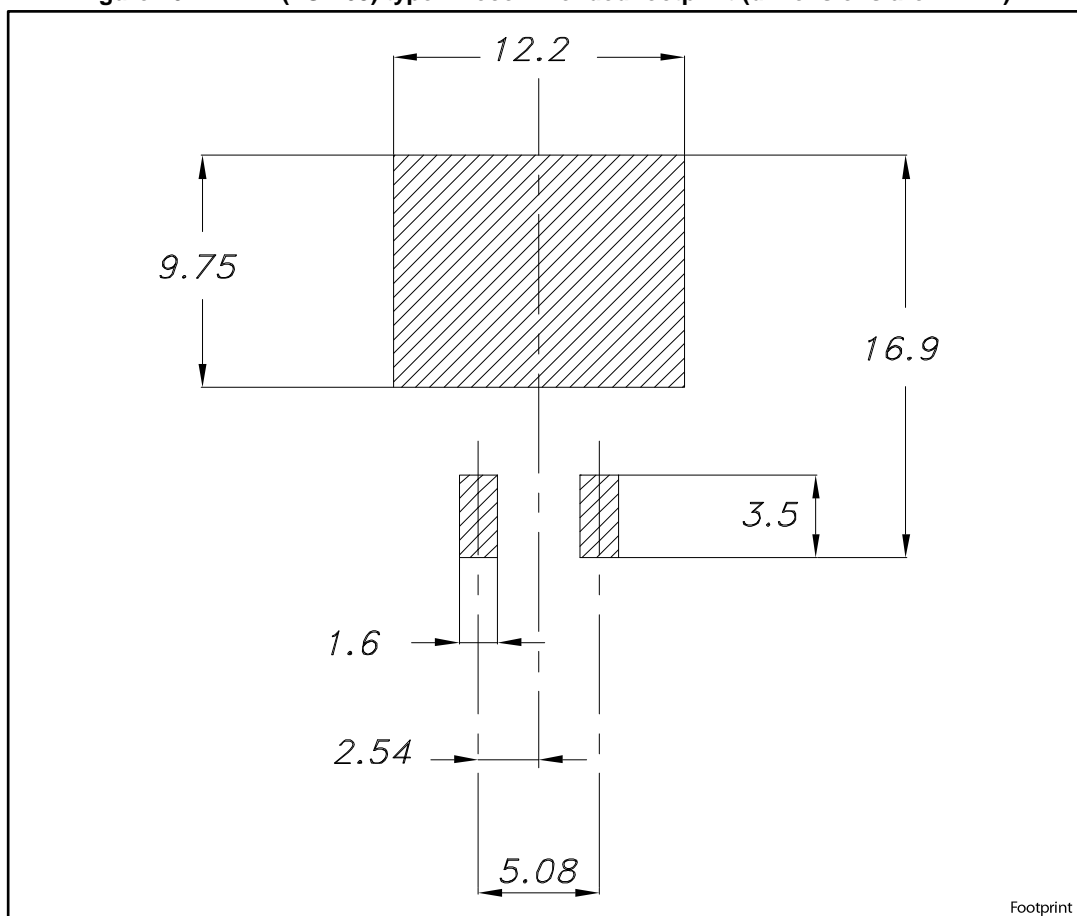

Table 10: D²PAK (TO-263) type B mechanical data

Dim.	mm		
	Min.	Typ.	Max.
A	4.36		4.56
A1	0		0.25
b	0.70		0.90
b1	0.51		0.89
b2	1.17		1.37
b3	1.36		1.46
c	0.38		0.694
c1	0.38		0.534
c2	1.19		1.34
D	8.60		9.00
D1	6.90		7.50
E	10.15		10.55
E1	8.10		8.70
e	2.54 BSC		
H	15.00		15.60
L	1.90		2.50
L1			1.65
L2			1.78
L3		0.25	
L4	4.78		5.28

Figure 26: D²PAK (TO-263) type B recommended footprint (dimensions are in mm)



4.3 D²PAK type A packing information

Figure 27: D²PAK type A tape outline

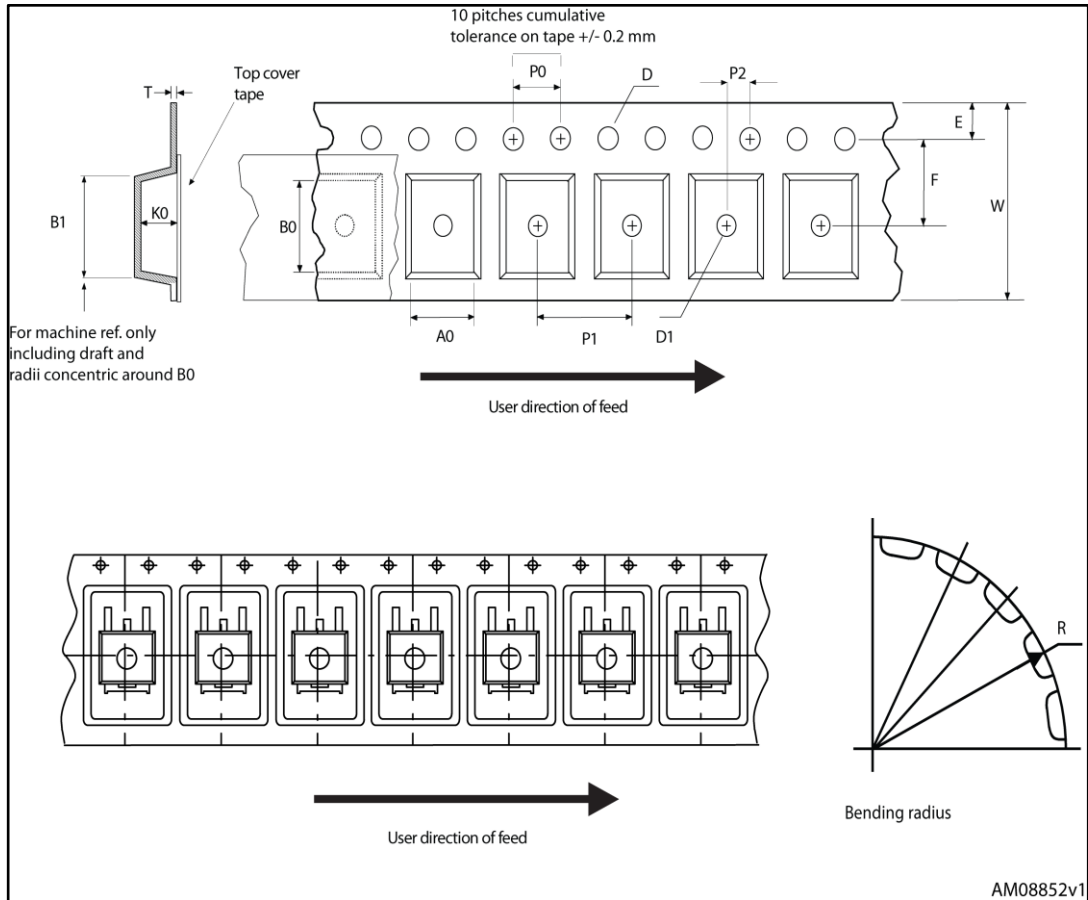

Figure 28: D²PAK type A reel outline

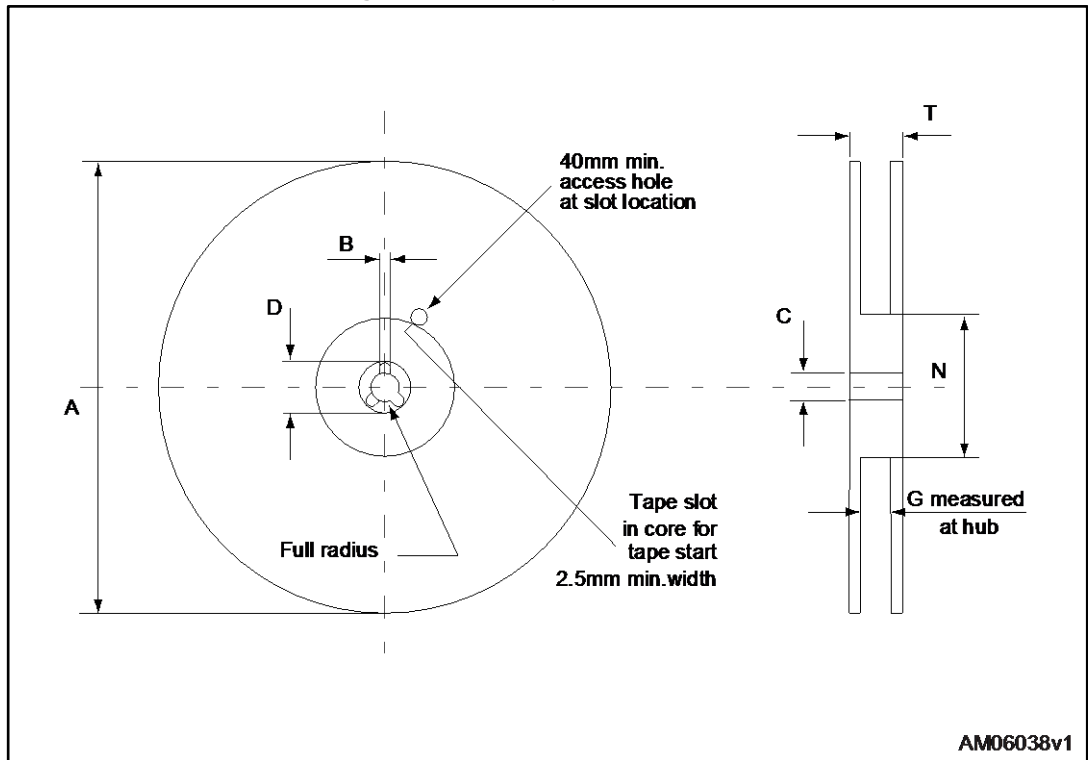

Table 11: D²PAK type A tape and reel mechanical data

Tape			Reel		
Dim.	mm		Dim.	mm	
	Min.	Max.		Min.	Max.
A0	10.5	10.7	A		330
B0	15.7	15.9	B	1.5	
D	1.5	1.6	C	12.8	13.2
D1	1.59	1.61	D	20.2	
E	1.65	1.85	G	24.4	26.4
F	11.4	11.6	N	100	
K0	4.8	5.0	T		30.4
P0	3.9	4.1			
P1	11.9	12.1	Base quantity		1000
P2	1.9	2.1	Bulk quantity		1000
R	50				
T	0.25	0.35			
W	23.7	24.3			

4.4 D²PAK type B packing information

Figure 29: D²PAK type B tape outline

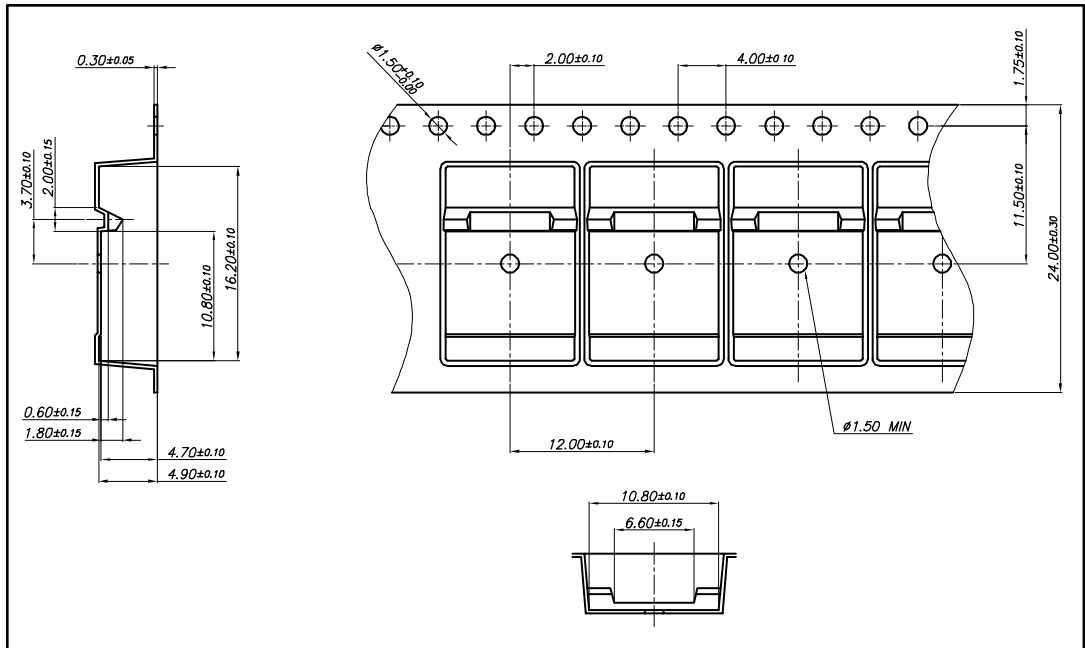
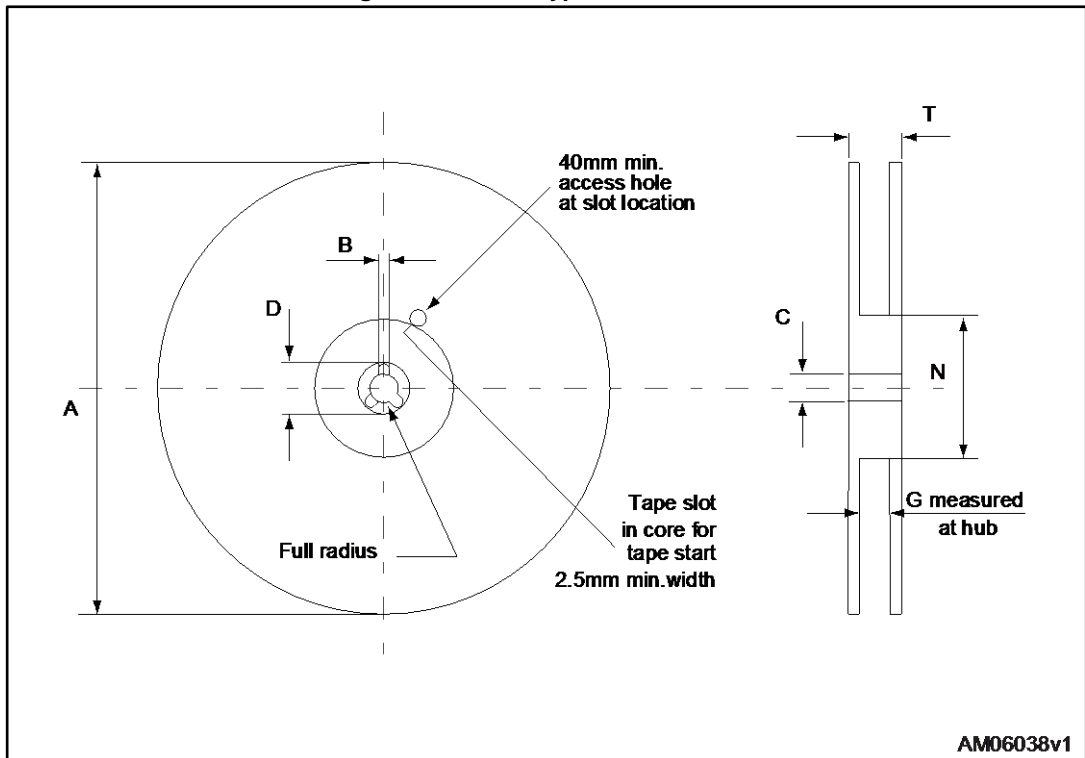

Figure 30: D²PAK type B reel outline



AM06038v1

Table 12: D²PAK type B reel mechanical data

Dim.	mm	
	Min.	Max.
A		330
B	1.5	
C	12.8	13.2
D	20.2	
G	24.4	26.4
N	100	
T		30.4

4.5 TO-220FP package information

Figure 31: TO-220FP package outline

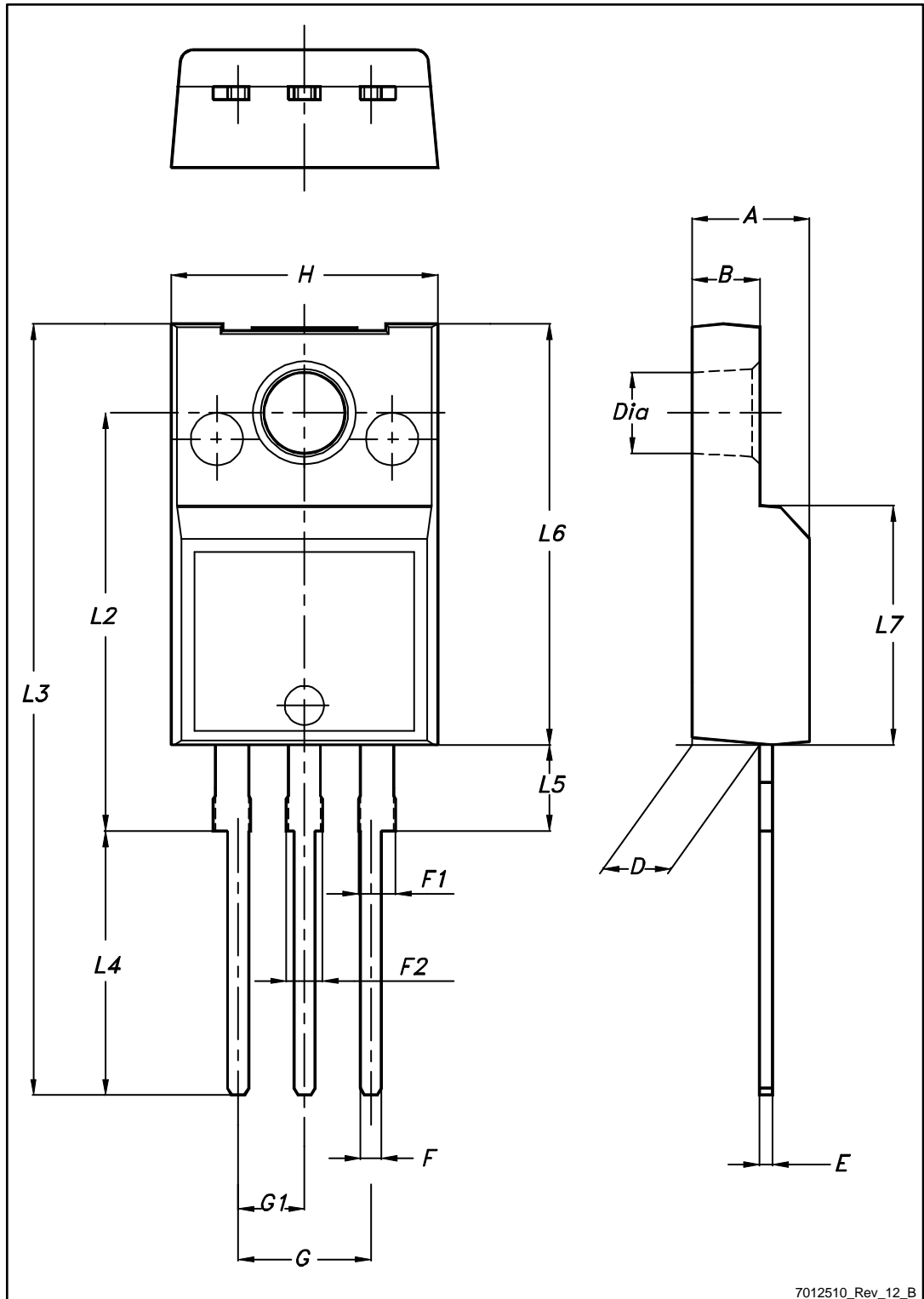

7012510_Rev_12_B

Table 13: TO-220FP package mechanical data

Dim.	mm		
	Min.	Typ.	Max.
A	4.4		4.6
B	2.5		2.7
D	2.5		2.75
E	0.45		0.7
F	0.75		1
F1	1.15		1.70
F2	1.15		1.70
G	4.95		5.2
G1	2.4		2.7
H	10		10.4
L2		16	
L3	28.6		30.6
L4	9.8		10.6
L5	2.9		3.6
L6	15.9		16.4
L7	9		9.3
Dia	3		3.2

4.6 TO-220 type A package information

Figure 32: TO-220 type A package outline



0015988_typeA_Rev_21

Table 14: TO-220 type A package mechanical data

Dim.	mm		
	Min.	Typ.	Max.
A	4.40		4.60
b	0.61		0.88
b1	1.14		1.55
c	0.48		0.70
D	15.25		15.75
D1		1.27	
E	10.00		10.40
e	2.40		2.70
e1	4.95		5.15
F	1.23		1.32
H1	6.20		6.60
J1	2.40		2.72
L	13.00		14.00
L1	3.50		3.93
L20		16.40	
L30		28.90	
øP	3.75		3.85
Q	2.65		2.95

5 Revision history

Table 15: Document revision history

Date	Revision	Changes
08-May-2008	1	Initial release
28-May-2008	2	– Value on Table 3: Thermal resistance has been changed. – Inserted Figure 16: Thermal impedance for TO-220, D ² PAK and Figure 17: Thermal impedance for TO-220FP
31-Jul-2012	3	Added: Figure 18 and Figure 19 on page 8.
17-Jul-2017	4	Modified internal schematic diagram on cover page Modified <i>Table 2: "Absolute maximum ratings"</i> , <i>Table 3: "Thermal data"</i> , and <i>Table 4: "Static characteristics"</i> . Modified <i>Figure 3: "Transfer characteristics"</i> , <i>Figure 4: "Collector-emitter on voltage vs temperature"</i> and <i>Figure 8: "Collector-emitter on voltage vs collector current"</i> . Updated <i>Section 4: "Package information"</i> . Minor text changes.

IMPORTANT NOTICE – PLEASE READ CAREFULLY

STMicroelectronics NV and its subsidiaries ("ST") reserve the right to make changes, corrections, enhancements, modifications, and improvements to ST products and/or to this document at any time without notice. Purchasers should obtain the latest relevant information on ST products before placing orders. ST products are sold pursuant to ST's terms and conditions of sale in place at the time of order acknowledgement.

Purchasers are solely responsible for the choice, selection, and use of ST products and ST assumes no liability for application assistance or the design of Purchasers' products.

No license, express or implied, to any intellectual property right is granted by ST herein.

Resale of ST products with provisions different from the information set forth herein shall void any warranty granted by ST for such product.

ST and the ST logo are trademarks of ST. All other product or service names are the property of their respective owners.

Information in this document supersedes and replaces information previously supplied in any prior versions of this document.

© 2017 STMicroelectronics – All rights reserved

Компания «Life Electronics» занимается поставками электронных компонентов импортного и отечественного производства от производителей и со складов крупных дистрибьюторов Европы, Америки и Азии.

С конца 2013 года компания активно расширяет линейку поставок компонентов по направлению коаксиальный кабель, кварцевые генераторы и конденсаторы (керамические, пленочные, электролитические), за счёт заключения дистрибьюторских договоров

Мы предлагаем:

- Конкурентоспособные цены и скидки постоянным клиентам.
- Специальные условия для постоянных клиентов.
- Подбор аналогов.
- Поставку компонентов в любых объемах, удовлетворяющих вашим потребностям.
- Приемлемые сроки поставки, возможна ускоренная поставка.
- Доставку товара в любую точку России и стран СНГ.
- Комплексную поставку.
- Работу по проектам и поставку образцов.
- Формирование склада под заказчика.
- Сертификаты соответствия на поставляемую продукцию (по желанию клиента).
- Тестирование поставляемой продукции.
- Поставку компонентов, требующих военную и космическую приемку.
- Входной контроль качества.
- Наличие сертификата ISO.

В составе нашей компании организован Конструкторский отдел, призванный помогать разработчикам, и инженерам.

Конструкторский отдел помогает осуществить:

- Регистрацию проекта у производителя компонентов.
- Техническую поддержку проекта.
- Защиту от снятия компонента с производства.
- Оценку стоимости проекта по компонентам.
- Изготовление тестовой платы монтаж и пусконаладочные работы.



Тел: +7 (812) 336 43 04 (многоканальный)

Email: org@lifeelectronics.ru