

THE INFORMATION CONTAINED HEREIN IS CONSIDERED 'PROPRIETARY' TO BEL FUSE INC. AND SHALL NOT BE COPIED, REPRODUCED OR DISCLOSED WITHOUT THE WRITTEN APPROVAL OF BEL FUSE INC.

RoHS

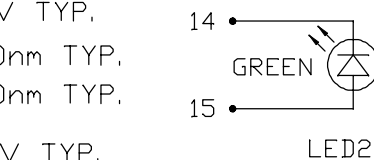

LED1 POLARITY			LED2 POLARITY		
PIN 12	PIN 13	COLOR	PIN 14	PIN 15	COLOR
-	+	GREEN	-	+	GREEN
+	-	YELLOW			

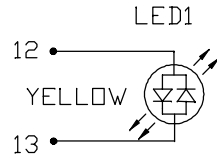

**ELECTRICAL CHARACTERISTICS @ 25°C**

URNS RATIO	1CT : 1CT ±2%
OCL @ 100kHz/100mVRMS	
8mA DC BIAS	350µH MIN.
INSERTION LOSS	
100KHz TO 100MHz	-1.5 dB MAX.
RETURN LOSS (MIN.)	
2MHz-30MHz	-16 dB MIN.
60MHz-80MHz	-10 dB MIN.
CROSS TALK	
100KHz - 100MHz	-30 dB MIN.
HIPOT (ISOLATION VOLTAGE)	2250 VDC
100% OF PRODUCTION TESTED TO COMPLY WITH IEEE 802.3 ISOLATION REQUIREMENTS	
BALANCED DC LINE CURRENT	350mA MAX. @ 57 VDC CONTINUOUS
	500mA MAX. @ 57 VDC FOR 200 MILLSECONDS
LED 1	
VF (FORWARD VOLTAGE)	IF=20mA GREEN 2.2V TYP.
	IF=20mA YELLOW 2.1V TYP.
λ (DOMINANT WAVELENGTH)	IF=20mA GREEN 570nm TYP.
	IF=20mA YELLOW 590nm TYP.
LED 2	
VF (FORWARD VOLTAGE)	IF=20mA GREEN 2.2V TYP.
λ (DOMINANT WAVELENGTH)	IF=20mA GREEN 570nm TYP.
OPERATING TEMPERATURE: 0°C TO +70°C.	

**SCHEMATIC**

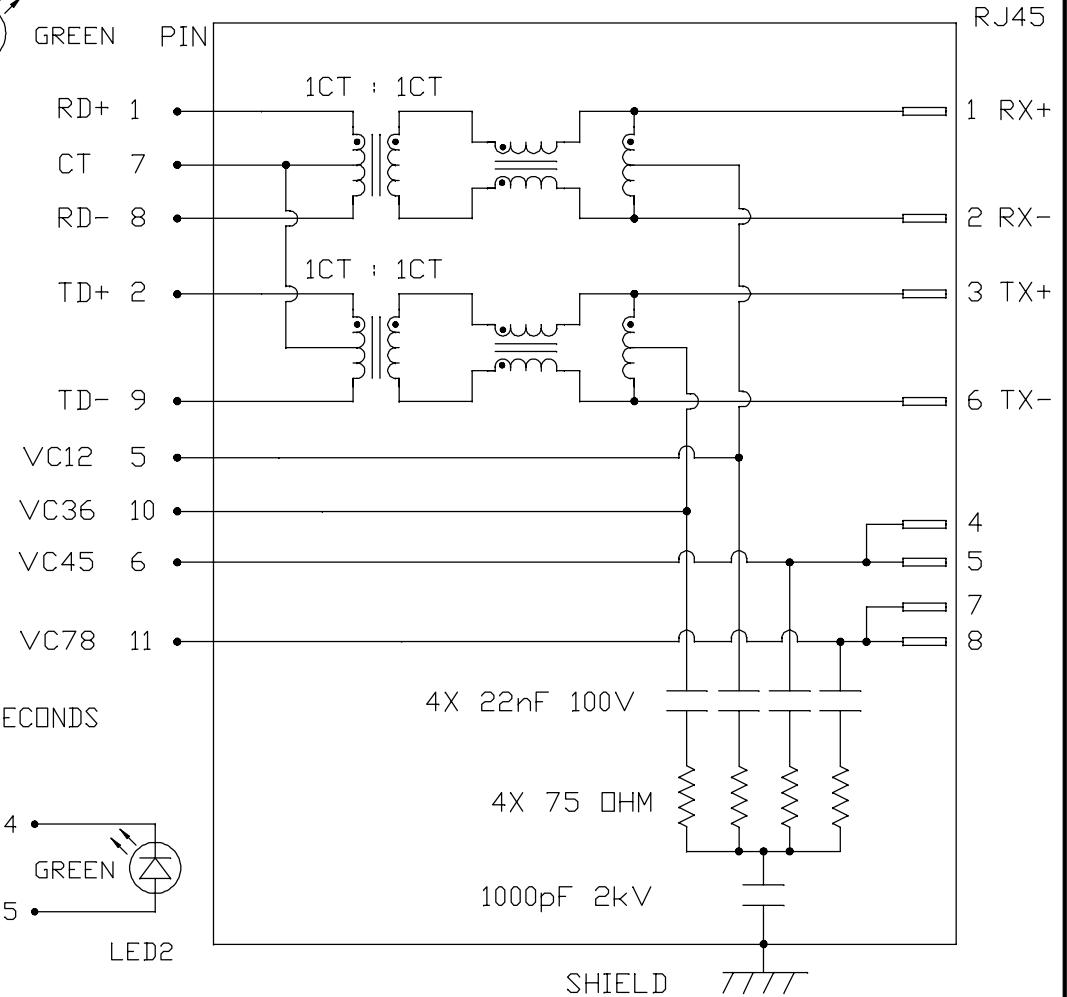

ORIGINATED BY  
CHOW WANCHUNG  
DATE 2016-08-11  
DRAWN BY  
SKY YOU  
DATE 2016-08-11

TITLE  
10/100 MagJack®  
PoE  
0826-1L1T-57-F

PART NO. / DRAWING NO.  
08261L1T57-F  
FILE NAME  
08261L1T57-F\_F.DWG

STANDARD DIM. [ ] METRIC DIM.  
TOL. IN INCH AS REF.  
.x UNIT : INCH [mm]  
.XX SCALE : N/A  
.XXX SIZE : A4

REV. : F PAGE : 2



THE INFORMATION CONTAINED HEREIN IS CONSIDERED "PROPRIETARY" TO BEL FUSE INC. AND SHALL NOT BE COPIED, REPRODUCED OR DISCLOSED WITHOUT THE WRITTEN APPROVAL OF BEL FUSE INC.

MECHANICAL SPECIFICATION

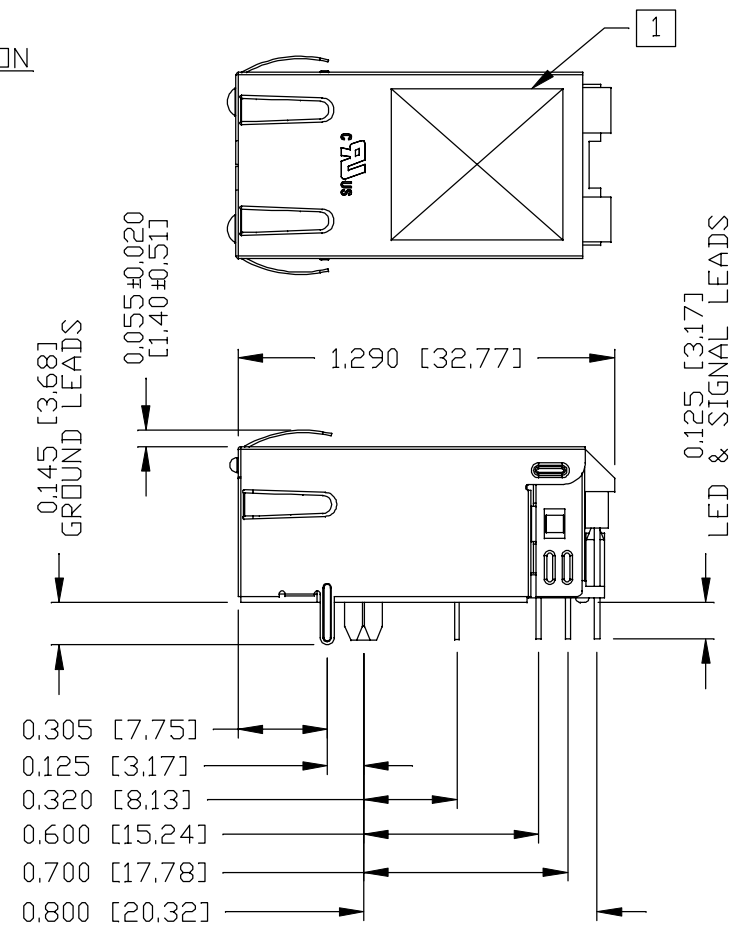
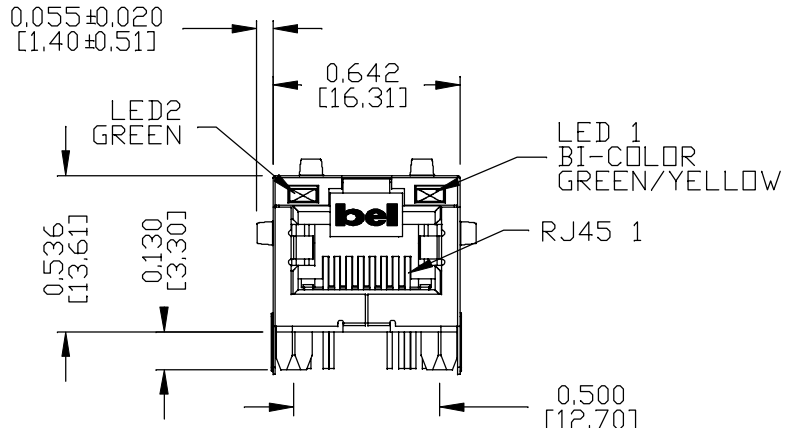

NOTES:

- PLASTIC HOUSING: THERMOPLASTIC PA, BLACK  
FLAMMABILITY RATING UL 94V-0
- CONTACTS: 50 MICRO-INCH HARD GOLD PLATING OR EQUIVALENT,  
30 MICRO-INCH MIN NICKEL UNDERPLATE.
- OUTPUT PINS: TIN-COATED COPPER WIRE, DIA 0.018 INCH,  
100 MICRO-INCH MIN MATTE TIN, PINS ARE SOLDER DIPPED.
- METAL SHIELD: NICKEL PLATED ON COPPER ALLOY,  
(ALL GROUND LEADS ARE SOLDER DIPPED)

1. MARK PART WITH MFG LOGO, MFG NAME, PART NUMBER, AND DATE CODE.

- 1. UL RECOGNIZED - FILE #E196366 AND E169987.
- 2. THE PRODUCT IS RoHS COMPLIANT.
- 3. JACK CAVITY CONFORMS TO FCC RULES AND REGULATIONS.
- 4. THE PART IS RECOMMENDED FOR WAVE SOLDERING. THE SUGGESTED PEAK WAVE SOLDERING CONDITION IS 260°C MAX AND 10 SECONDS MAX.

REV. : F PAGE : 3

ORIGINATED BY  
JESSE LI  
DATE 2016-08-11  
DRAWN BY  
JOLLY LUO  
DATE 2016-08-11

TITLE  
10/100 MagJack®  
PoE  
0826-1L1T-57-F

PART NO. / DRAWING NO.  
08261L1T57-F  
FILE NAME  
08261L1T57-F\_F.DWG

STANDARD DIM. TOL. IN INCH		[ ] METRIC DIM. AS REF.
.X		UNIT : INCH [mm]
.XX		SCALE : N/A
.XXX	±0.010	SIZE : A4



THE INFORMATION CONTAINED HEREIN IS CONSIDERED "PROPRIETARY" TO BEL FUSE INC. AND SHALL NOT BE COPIED, REPRODUCED OR DISCLOSED WITHOUT THE WRITTEN APPROVAL OF BEL FUSE INC.

RoHS

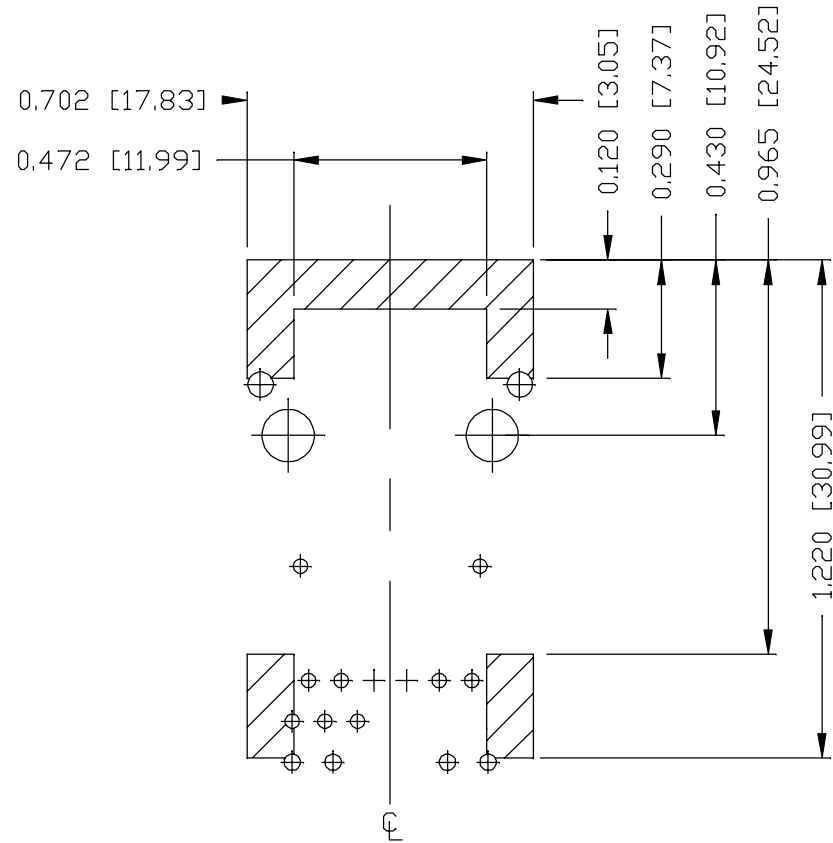

NOTES

THE SHADED AREA ON THE CUSTOMER BOARD ARE RECOMMENDED TO BE CLEAR OFF ANY VIA HOLE OR COMPONENT PAD.

ORIGINATED BY  
JESSE LI  
DATE 2016-08-11

DRAWN BY  
JOLLY LUO  
DATE 2016-08-11

TITLE  
10/100 MagJack®  
PoE  
0826-1L1T-57-F

PART NO. / DRAWING NO.  
08261L1T57-F  
FILE NAME  
08261L1T57-F\_F.DWG

STANDARD DIM. TOL. IN INCH	[ ] METRIC DIM. AS REF.
.X	UNIT : INCH [mm]
.XX	SCALE : N/A
.XXX	±0.004

REV. : F	PAGE : 4
----------	----------

a bel group

THE INFORMATION CONTAINED HEREIN IS CONSIDERED "PROPRIETARY" TO BEL FUSE INC. AND SHALL NOT BE COPIED, REPRODUCED OR DISCLOSED WITHOUT THE WRITTEN APPROVAL OF BEL FUSE INC.

RoHS



RECOMMENDED PCB FOOTPRINT  
COMPONENT SIDE VIEW

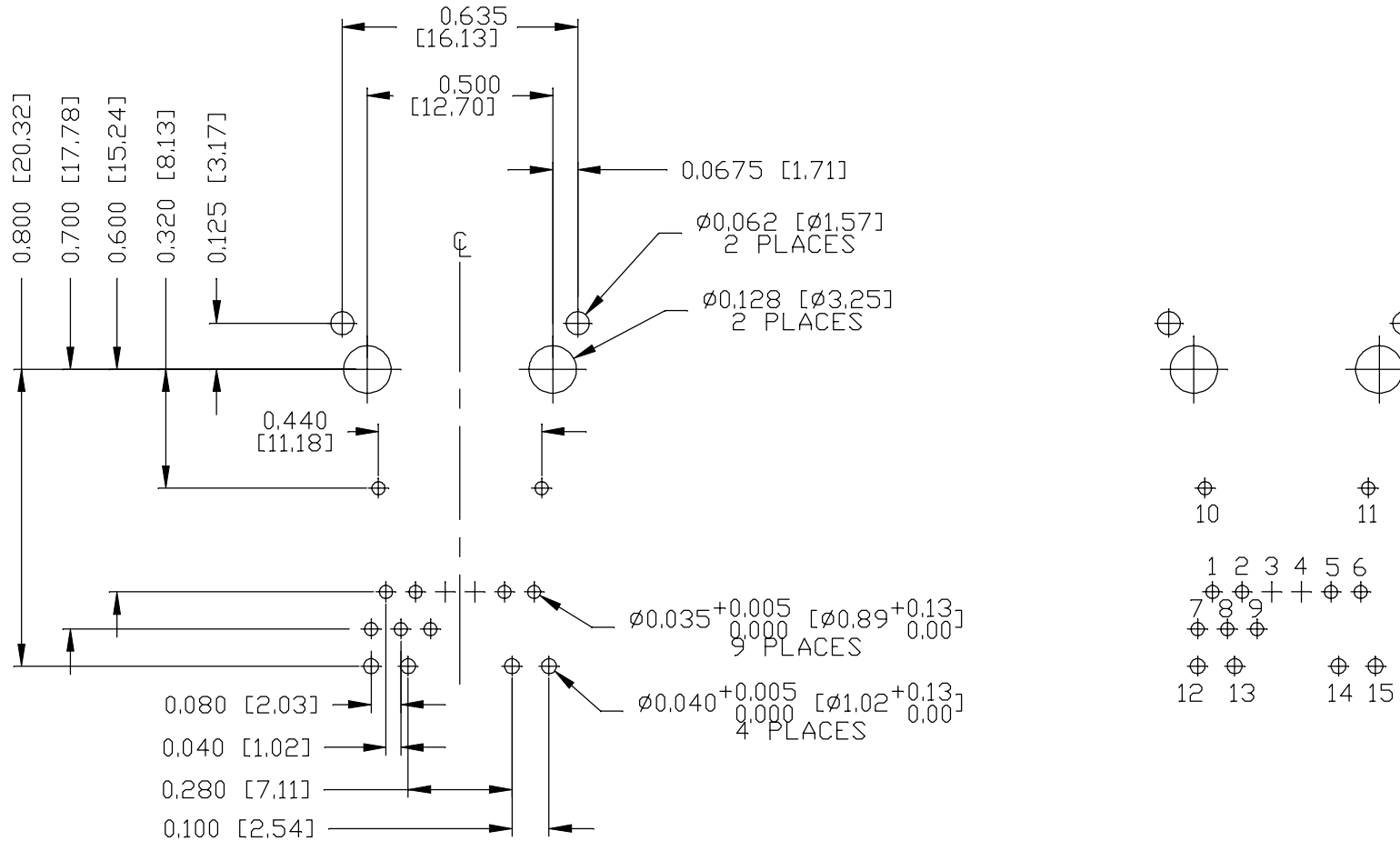

ORIGINATED BY  
JESSE LI  
DATE 2016-08-11  
DRAWN BY  
JOLLY LUD  
DATE 2016-08-11

TITLE  
10/100 MagJack®  
PoE  
0826-1L1T-57-F

PART NO. / DRAWING NO.  
08261L1T57-F  
FILE NAME  
08261L1T57-F\_F.DWG

STANDARD DIM. TOL. IN INCH		[ ] METRIC DIM. AS REF.
.X		UNIT : INCH [mm]
.XX		SCALE : N/A
.XXX	±0.004	SIZE : A4

REV. : F PAGE : 5



THE INFORMATION CONTAINED HEREIN IS CONSIDERED "PROPRIETARY" TO BEL FUSE INC. AND SHALL NOT BE COPIED, REPRODUCED OR DISCLOSED WITHOUT THE WRITTEN APPROVAL OF BEL FUSE INC.

RoHS



SUGGESTED PANEL OPENING

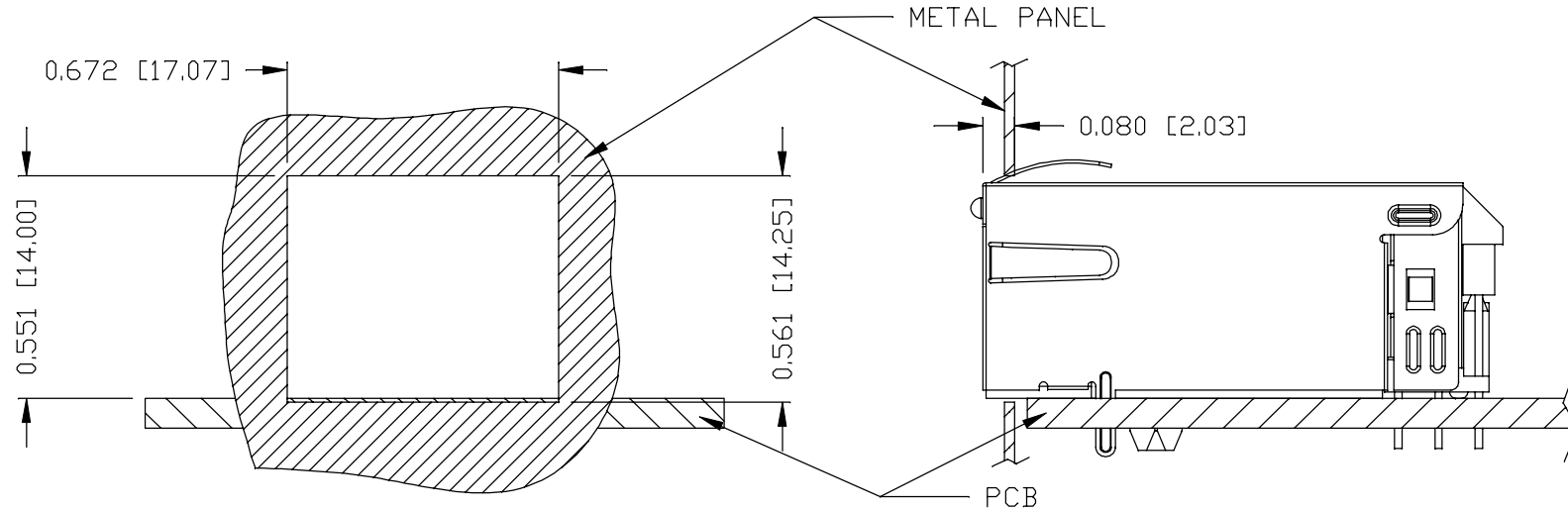

NOTE:

THE DISTANCE OF PANEL INSIDE SURFACE RELATIVE TO FRONT SURFACE OF PART IS ONLY A SUGGESTION. IN CASE THIS DISTANCE IS DIFFERENT, THE REQUIRED PANEL OPENING DIMENSIONS CHANGE ACCORDINGLY.

PACKING INFORMATION

PACKING TRAY : 0200-9999-F6 (TOP)  
0200-9999-F7 (BOTTOM)

PACKING QUANTITY : 40 PCS FINISHED GOODS PER TRAY  
10 TRAYS (400 PCS FINISHED GOODS) PER CARTON BOX

NOTE : CARDBOARDS ARE PLACED BETWEEN LAYERS OF PACKING TRAY INSIDE CARTON BOX  
(INCLUDE THE UPPERMOST AND LOWERMOST TRAY)

REV. : F PAGE : 6

ORIGINATED BY  
JESSE LI  
DATE 2016-08-11  
DRAWN BY  
JOLLY LUO  
DATE 2016-08-11

TITLE  
10/100 MagJack®  
PoE  
0826-1L1T-57-F

PART NO. / DRAWING NO.  
08261L1T57-F  
FILE NAME  
08261L1T57-F\_F.DWG

STANDARD DIM. TOL. IN INCH	[ ] METRIC DIM. AS REF.
.X	UNIT : INCH [mm]
.XX	SCALE : N/A
.XXX ±0.004	SIZE : A4



Компания «Life Electronics» занимается поставками электронных компонентов импортного и отечественного производства от производителей и со складов крупных дистрибьюторов Европы, Америки и Азии.

С конца 2013 года компания активно расширяет линейку поставок компонентов по направлению коаксиальный кабель, кварцевые генераторы и конденсаторы (керамические, пленочные, электролитические), за счёт заключения дистрибьюторских договоров

Мы предлагаем:

- Конкуренспособные цены и скидки постоянным клиентам.
- Специальные условия для постоянных клиентов.
- Подбор аналогов.
- Поставку компонентов в любых объемах, удовлетворяющих вашим потребностям.
- Приемлемые сроки поставки, возможна ускоренная поставка.
- Доставку товара в любую точку России и стран СНГ.
- Комплексную поставку.
- Работу по проектам и поставку образцов.
- Формирование склада под заказчика.
- Сертификаты соответствия на поставляемую продукцию (по желанию клиента).
- Тестирование поставляемой продукции.
- Поставку компонентов, требующих военную и космическую приемку.
- Входной контроль качества.
- Наличие сертификата ISO.

В составе нашей компании организован Конструкторский отдел, призванный помогать разработчикам, и инженерам.

Конструкторский отдел помогает осуществить:

- Регистрацию проекта у производителя компонентов.
- Техническую поддержку проекта.
- Защиту от снятия компонента с производства.
- Оценку стоимости проекта по компонентам.
- Изготовление тестовой платы монтаж и пусконаладочные работы.



Тел: +7 (812) 336 43 04 (многоканальный)

Email: [org@lifeelectronics.ru](mailto:org@lifeelectronics.ru)