

# TDK511xF Series

High Power 315/434/868 MHz,  
ASK/FSK Transmitters (-40 ... +125°C)

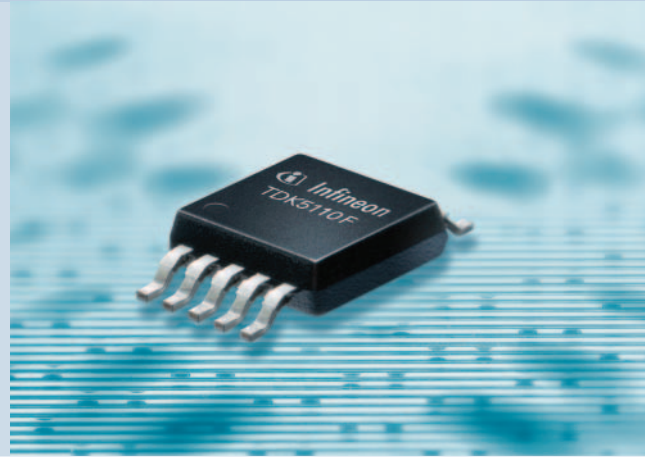

**WIRELESS CONTROL** – The TDK511xF series is a family of high power ASK/FSK transmitters for the frequency bands 311 – 317 MHz, 433 – 435 MHz and 868 – 870 MHz. The IC offers a high level of integration and needs only a few external components. The device contains a fully integrated PLL synthesizer and a high efficiency power amplifier to drive a loop antenna. A special circuit design and a unique power amplifier design are used to save current consumption and therefore to save battery life. Additional features like power down mode and divided clock output are implemented. The IC can be used for both ASK and FSK modulation.

## Applications

- Remote Keyless Entry (RKE) systems
- Tire Pressure Monitoring (TPM) systems
- Remote control systems
- Alarm systems
- Communication systems

## Ordering Information

Type	Ordering Code	Package
TDK5110F	SP000056180	PG-TSSOP-10
TDK5111F	SP000056181	PG-TSSOP-10
TDK5116F	SP000056182	PG-TSSOP-10

## Evaluation Kits

Type	Modulation	Frequency	Ordering Code
TDK5110F-TDA5210	FSK	434 MHz	SP000086722
TDK5111F-TDA5211	FSK	315 MHz	SP000086723
TDK5116F-TDA5210	FSK	868 KHz	SP000087099

## Features

- Frequency range  
311 – 317 MHz/433 – 435 MHz/868 – 870 MHz
- ASK and FSK modulation
- High efficiency power amplifier typically  
10 dBm @ 3 V
- Fully integrated frequency synthesizer
- VCO without external components
- Fully integrated frequency synthesizer
- Power down mode
- Divided clock output for  $\mu$ C
- Low external component count
- Integrated FSK-switch
- Low supply current typ. 14 mA @ 3 V
- Voltage supply range 2.1 – 4 V
- Temperature range -40 ... +125°C

[www.infineon.com/wireless](http://www.infineon.com/wireless)

# Wireless Control



Never stop thinking

## Block Diagram TDK5110F

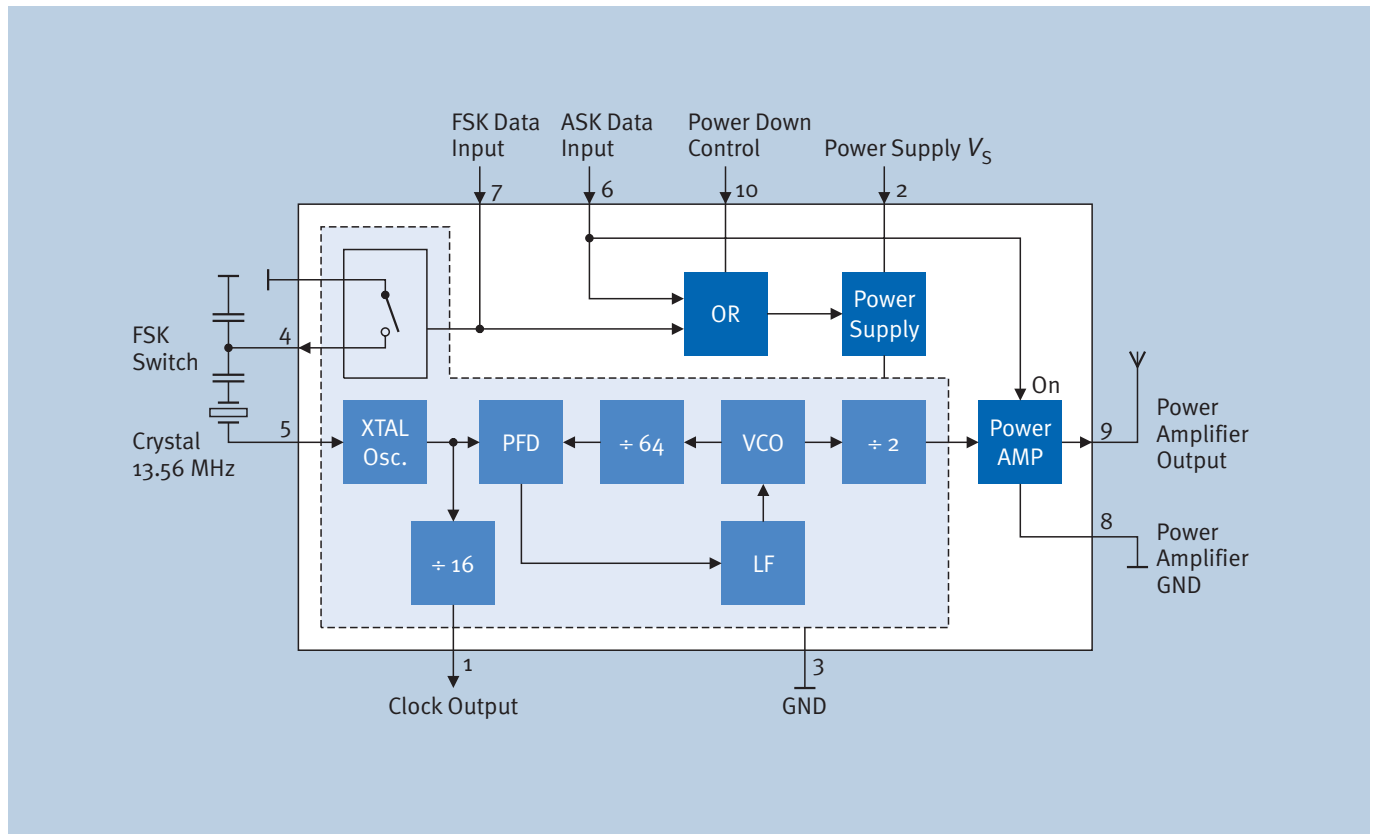

Type	TDK5110F	TDK5111F	TDK5116F
Frequency Range	433 – 435 MHz	311 – 317 MHz	868 – 870 MHz
Data Rate	20 kHz (ASK/FSK)	20 kHz (ASK/FSK)	20 kHz (ASK/FSK)
Supply Voltage	2.1 – 4 V	2.1 – 4 V	2.1 – 4 V
Supply Current typ. (PLL Enable Mode/Transmit Mode $V_s = 3 V$ )	4/14.2 mA	4/14 mA	4/14 mA
Power Down Current	4 $\mu A$	4 $\mu A$	4 $\mu A$
RF Transmit Power typ.	10.0 dBm	10.0 dBm	10.0 dBm
Package	PG-TSSOP-10	PG-TSSOP-10	PG-TSSOP-10
Temperature Range	-40°C ... +125°C	-40°C ... +125°C	-40°C ... +125°C

How to reach us:  
<http://www.infineon.com>

Published by  
 Infineon Technologies AG  
 81726 München, Germany

© Infineon Technologies AG 2006.  
 All Rights Reserved.

### Legal Disclaimer

The information given in this Product Brief shall in no event be regarded as a guarantee of conditions or characteristics ("Beschaffenheitsgarantie"). With respect to any examples or hints given herein, any typical values stated herein and/or any information regarding the application of the device, Infineon Technologies hereby disclaims any and all warranties and liabilities of any kind, including without limitation warranties of non-infringement of intellectual property rights of any third party.

### Information

For further information on technology, delivery terms and conditions and prices please contact your nearest Infineon Technologies Office ([www.infineon.com](http://www.infineon.com)).

### Warnings

Due to technical requirements components may contain dangerous substances. For information on the types in question please contact your nearest Infineon Technologies Office.

Infineon Technologies Components may only be used in life-support devices or systems with the express written approval of Infineon Technologies, if a failure of such components can reasonably be expected to cause the failure of that life-support device or system, or to affect the safety or effectiveness of that device or system. Life support devices or systems are intended to be implanted in the human body, or to support and/or maintain and sustain and/or protect human life. If they fail, it is reasonable to assume that the health of the user or other persons may be endangered.

Ordering No. B138-H8689-G1-X-7600  
 Printed in Germany  
 PS 0506.5 nb

Компания «Life Electronics» занимается поставками электронных компонентов импортного и отечественного производства от производителей и со складов крупных дистрибьюторов Европы, Америки и Азии.

С конца 2013 года компания активно расширяет линейку поставок компонентов по направлению коаксиальный кабель, кварцевые генераторы и конденсаторы (керамические, пленочные, электролитические), за счёт заключения дистрибьюторских договоров

Мы предлагаем:

- Конкурентоспособные цены и скидки постоянным клиентам.
- Специальные условия для постоянных клиентов.
- Подбор аналогов.
- Поставку компонентов в любых объемах, удовлетворяющих вашим потребностям.
- Приемлемые сроки поставки, возможна ускоренная поставка.
- Доставку товара в любую точку России и стран СНГ.
- Комплексную поставку.
- Работу по проектам и поставку образцов.
- Формирование склада под заказчика.
- Сертификаты соответствия на поставляемую продукцию (по желанию клиента).
- Тестирование поставляемой продукции.
- Поставку компонентов, требующих военную и космическую приемку.
- Входной контроль качества.
- Наличие сертификата ISO.

В составе нашей компании организован Конструкторский отдел, призванный помогать разработчикам, и инженерам.

Конструкторский отдел помогает осуществить:

- Регистрацию проекта у производителя компонентов.
- Техническую поддержку проекта.
- Защиту от снятия компонента с производства.
- Оценку стоимости проекта по компонентам.
- Изготовление тестовой платы монтаж и пусконаладочные работы.



Тел: +7 (812) 336 43 04 (многоканальный)

Email: [org@lifeelectronics.ru](mailto:org@lifeelectronics.ru)