

N-channel 80 V, 0.0017  $\Omega$  typ., 180 A, STripFET™ F7  
Power MOSFETs in H<sup>2</sup>PAK-2, H<sup>2</sup>PAK-6 and TO-220 packages

Datasheet – production data

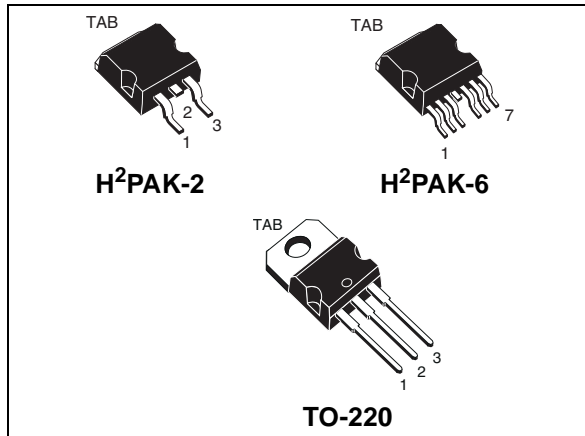
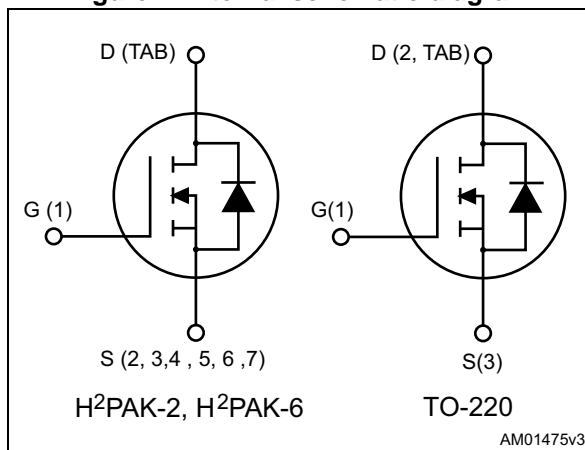

Figure 1. Internal schematic diagram



## Features

Order codes	V <sub>DS</sub>	R <sub>DS(on)</sub> max	I <sub>D</sub>
STH270N8F7-2	80 V	0.0021 $\Omega$	180 A
STH270N8F7-6			
STP270N8F7		0.0025 $\Omega$	

- Among the lowest R<sub>DS(on)</sub> on the market
- Excellent figure of merit (FoM)
- Low C<sub>rss</sub>/C<sub>iss</sub> ratio for EMI immunity
- High avalanche ruggedness

## Applications

- Switching applications

## Description

These N-channel Power MOSFETs utilize STripFET™ F7 technology with an enhanced trench gate structure that results in very low on-state resistance, while also reducing internal capacitance and gate charge for faster and more efficient switching.

Table 1. Device summary

Order codes	Marking	Package	Packaging
STH270N8F7-2	270N8F7	H <sup>2</sup> PAK-2	Tape and reel
STH270N8F7-6		H <sup>2</sup> PAK-6	
STP270N8F7		TO-220	Tube

# Contents

- 1      Electrical ratings ..... 3**
- 2      Electrical characteristics ..... 4**
- 3      Electrical characteristics (curves) ..... 6**
- 4      Test circuits ..... 9**
- 5      Package information ..... 10**
  - 5.1    H<sup>2</sup>PAK-2 package information ..... 11
  - 5.2    H<sup>2</sup>PAK-6 package information ..... 14
  - 5.3    TO-220 type A package information ..... 17
- 6      Packing information ..... 19**
- 7      Revision history ..... 21**

# 1 Electrical ratings

**Table 2. Absolute maximum ratings**

Symbol	Parameter	Value	Unit
$V_{DS}$	Drain-source voltage	80	V
$V_{GS}$	Gate-source voltage	$\pm 20$	V
$I_D^{(1)}$	Drain current (continuous)	180	A
$I_D^{(1)}$	Drain current (continuous) at $T_C = 100\text{ }^\circ\text{C}$	180	A
$I_{DM}^{(2)}$	Drain current (pulsed)	720	A
$P_{TOT}^{(3)}$	Total dissipation at $T_C = 25\text{ }^\circ\text{C}$	315	W
$E_{AS}^{(4)}$	Single pulse avalanche energy	1.16	J
$T_J$	Operating junction temperature	-55 to 175	$^\circ\text{C}$
$T_{stg}$	Storage temperature		$^\circ\text{C}$

1. Limited by package
2. Pulse width limited by safe operating area
3. This value is rated according to  $R_{thj-c}$
4. Starting  $T_j = 25\text{ }^\circ\text{C}$ ,  $I_d = 65\text{ A}$ ,  $V_{dd} = 50\text{ V}$

**Table 3. Thermal resistance**

Symbol	Parameter	Value		Unit
		H <sup>2</sup> PAK-2, H <sup>2</sup> PAK-6	TO-220	
$R_{thj-case}$	Thermal resistance junction-case	0.48		$^\circ\text{C/W}$
$R_{thj-pcb}^{(1)}$	Thermal resistance junction-pcb	35		$^\circ\text{C/W}$
$R_{thj-amb}$	Thermal resistance junction-ambient max		62.5	$^\circ\text{C/W}$

1. When mounted on FR-4 board of 1 inch<sup>2</sup>, 2oz Cu

## 2 Electrical characteristics

( $T_{CASE}=25\text{ °C}$  unless otherwise specified)

**Table 4. On/off states**

Symbol	Parameter	Test conditions	Min.	Typ.	Max.	Unit
$V_{(BR)DSS}$	Drain-source breakdown voltage ( $V_{GS}=0$ )	$I_D = 250\ \mu\text{A}$	80			V
$I_{DSS}$	Zero gate voltage drain current ( $V_{GS}=0$ )	$V_{DS} = 80\text{ V}$ $V_{DS} = 80\text{ V}; T_C=125\text{ °C}$			10 100	$\mu\text{A}$ $\mu\text{A}$
$I_{GSS}$	Gate body leakage current ( $V_{DS}=0$ )	$V_{GS} = +20\text{ V}$			100	nA
$V_{GS(th)}$	Gate threshold voltage	$V_{DS}=V_{GS}, I_D = 250\ \mu\text{A}$	2		4	V
$R_{DS(on)}$	Static drain-source on-resistance	For H <sup>2</sup> PAK-2, H <sup>2</sup> PAK-6: $V_{GS} = 10\text{ V}, I_D = 90\text{ A}$		0.0017	0.0021	$\Omega$
		For TO-220: $V_{GS} = 10\text{ V}, I_D = 90\text{ A}$		0.0021	0.0025	

**Table 5. Dynamic**

Symbol	Parameter	Test conditions	Min.	Typ.	Max.	Unit
$C_{iss}$	Input capacitance	$V_{DS}=50\text{ V}, f=1\text{ MHz},$ $V_{GS}=0$	-	13600	-	pF
$C_{oss}$	Output capacitance		-	2050	-	pF
$C_{rss}$	Reverse transfer capacitance		-	236	-	pF
$Q_g$	Total gate charge	$V_{DD}=40\text{ V}, I_D = 180\text{ A}$ $V_{GS} = 10\text{ V}$ <i>Figure 19</i>	-	193	-	nC
$Q_{gs}$	Gate-source charge		-	96	-	nC
$Q_{gd}$	Gate-drain charge		-	46	-	nC

**Table 6. Switching times**

Symbol	Parameter	Test conditions	Min.	Typ.	Max.	Unit
$t_{d(on)}$	Turn-on delay time	$V_{DD}=40\text{ V}, I_D = 90\text{ A},$ $R_G=4.7\ \Omega, V_{GS} = 10\text{ V}$ <i>Figure 18</i>	-	56	-	ns
$t_r$	Rise time		-	180	-	ns
$t_{d(off)}$	Turn-off delay time		-	98	-	ns
$t_f$	Fall time		-	42	-	ns

**Table 7. Source drain diode**

Symbol	Parameter	Test conditions	Min	Typ.	Max	Unit
$I_{SD}$	Source-drain current		-		180	A
$I_{SDM}^{(1)}$	Source-drain current (pulsed)		-		720	A
$V_{SD}^{(2)}$	Forward on voltage	$I_{SD} = 90 \text{ A}, V_{GS}=0$	-		1.2	V
$t_{rr}$	Reverse recovery time	$I_{SD} = 180 \text{ A},$ $di/dt = 100 \text{ A}/\mu\text{s},$ $V_{DD}=64 \text{ V}, T_j=150 \text{ }^\circ\text{C}$	-	78		ns
$Q_{rr}$	Reverse recovery charge		-	182		nC
$I_{RRM}$	Reverse recovery current		-	4.7		A

1. Pulse width limited by safe operating area
2. Pulsed: pulse duration=300 $\mu\text{s}$ , duty cycle 1.5%

### 3 Electrical characteristics (curves)

Figure 2. Safe operating area for H<sup>2</sup>PAK-2 and H<sup>2</sup>PAK-6

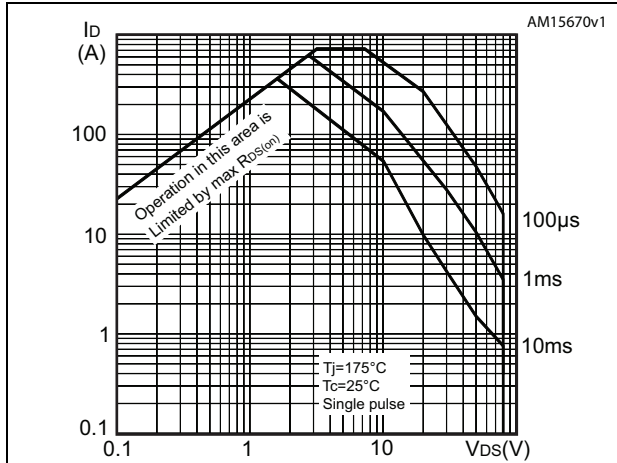

Figure 3. Safe operating area for TO-220

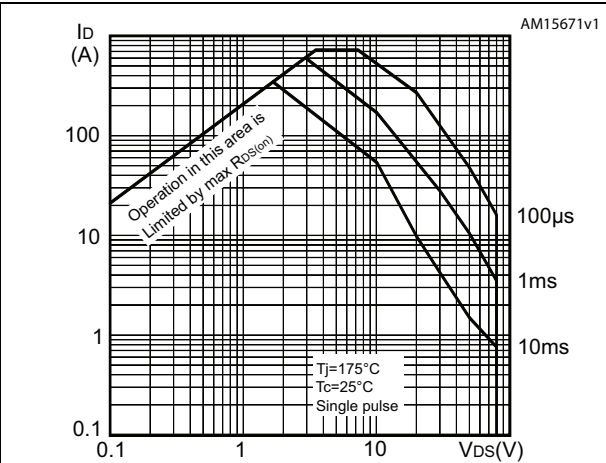

Figure 4. Thermal impedance

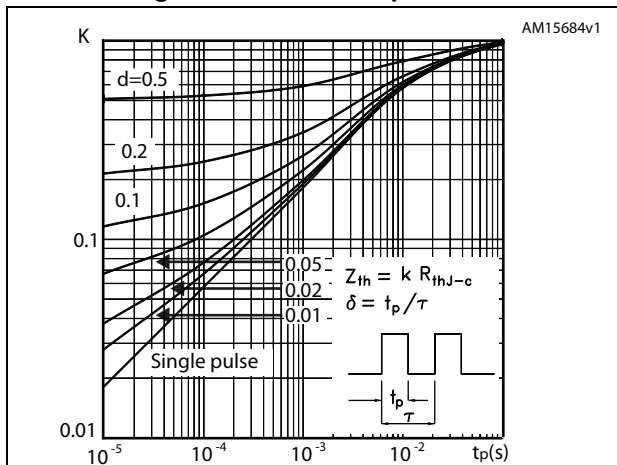

Figure 5. Gate charge vs gate-source voltage

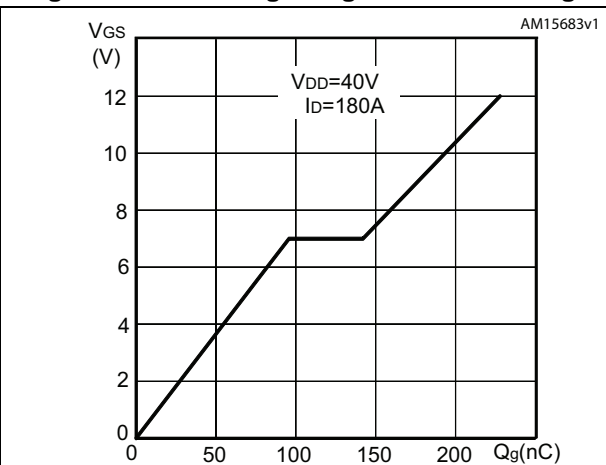

Figure 6. Output characteristics for TO-220

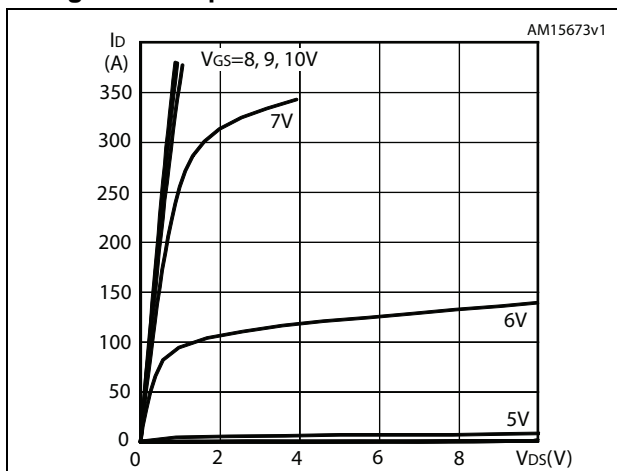

Figure 7. Transfer characteristics for TO-220

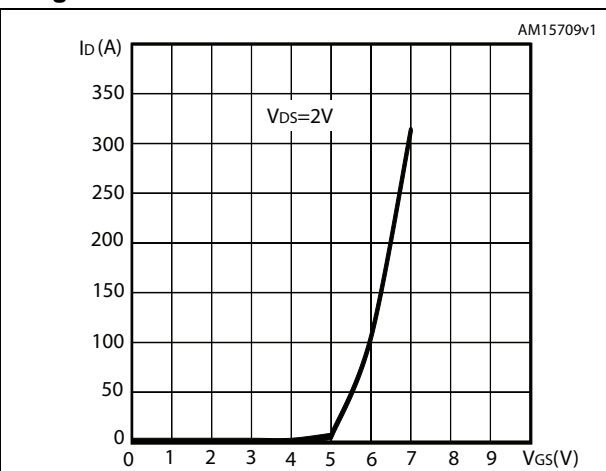

Figure 8. Output characteristics for H<sup>2</sup>PAK-2 and H<sup>2</sup>PAK-6

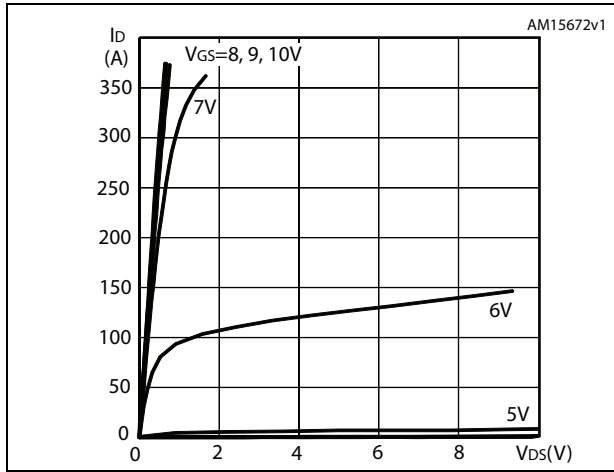

Figure 9. Transfer characteristics for H<sup>2</sup>PAK-2 and H<sup>2</sup>PAK-6

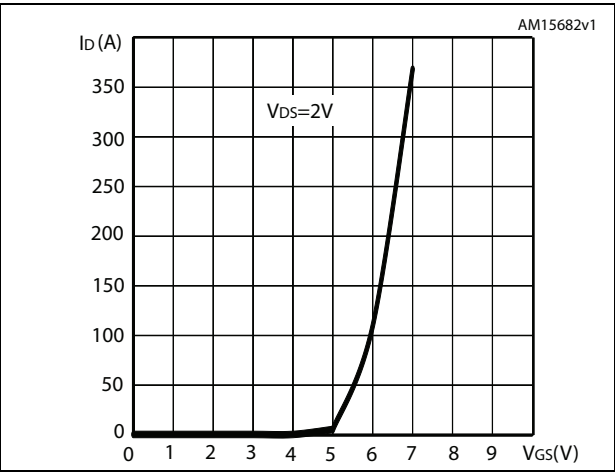

Figure 10. Normalized V<sub>(BR)DSS</sub> vs temperature

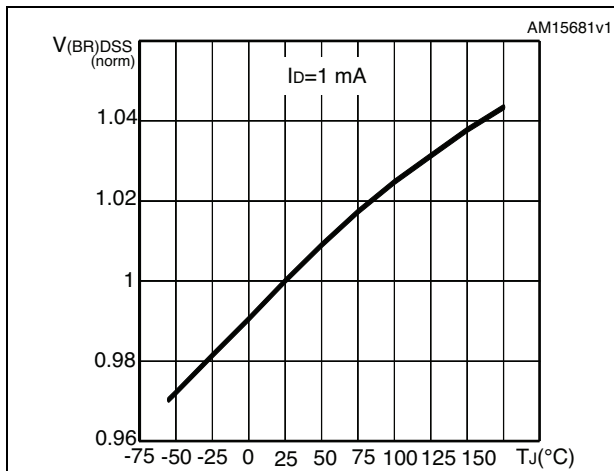

Figure 11. Static drain-source on-resistance for H<sup>2</sup>PAK-2 and H<sup>2</sup>PAK-6

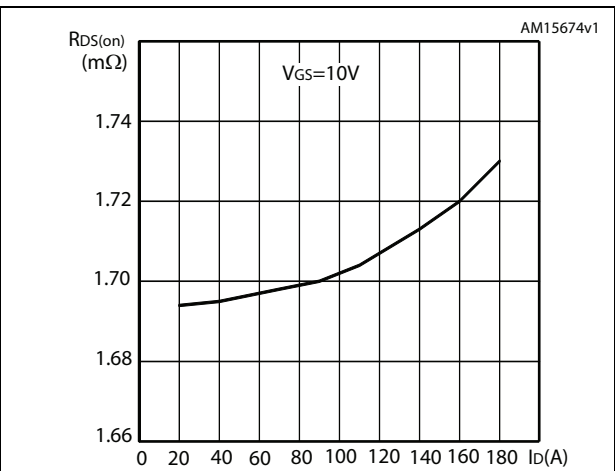

Figure 12. Static drain-source on-resistance for TO-220

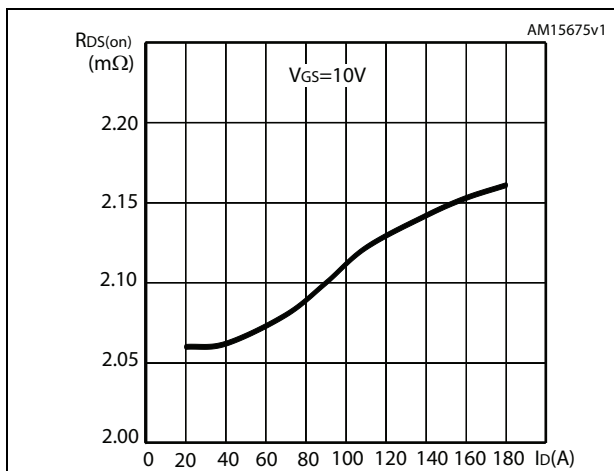

Figure 13. Capacitance variations

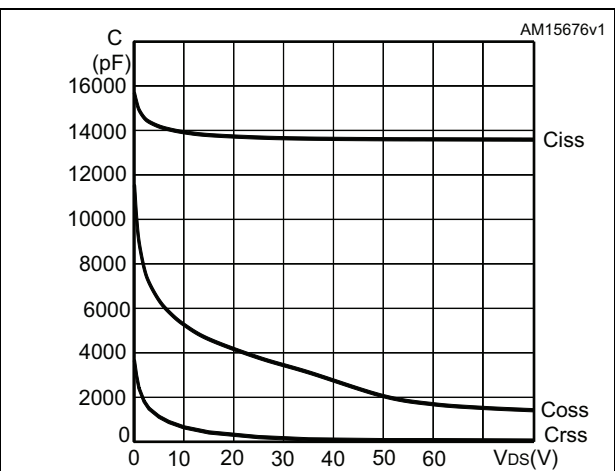

Figure 14. Source-drain diode forward characteristics

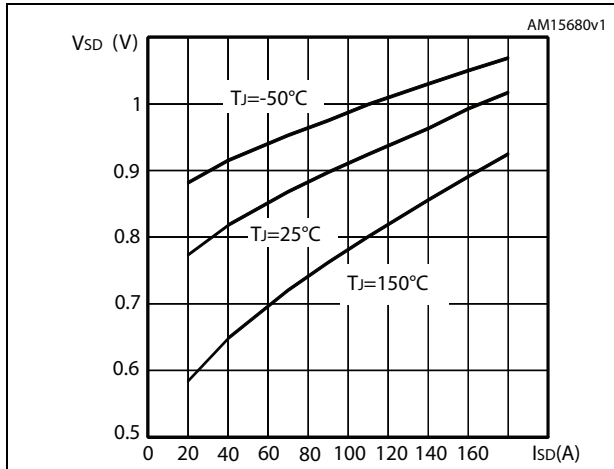

Figure 15. Normalized gate threshold voltage vs temperature

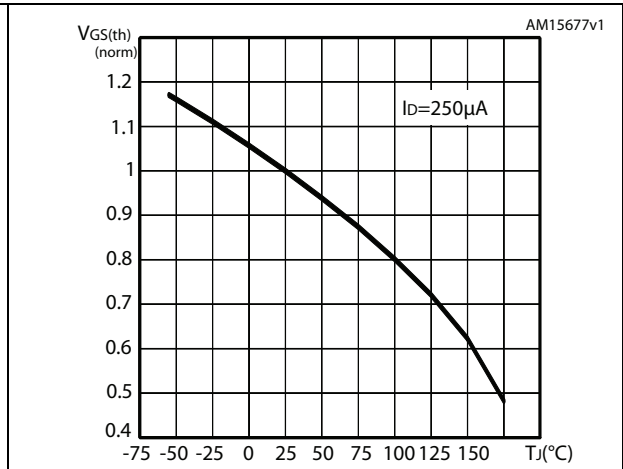

Figure 16. Normalized on-resistance vs temperature for H<sup>2</sup>PAK-2 and H<sup>2</sup>PAK-6

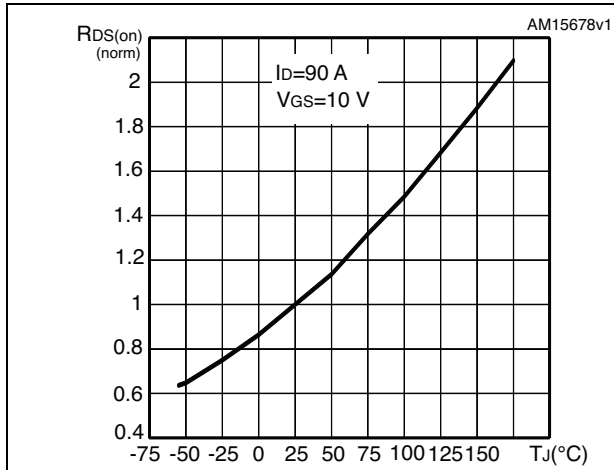
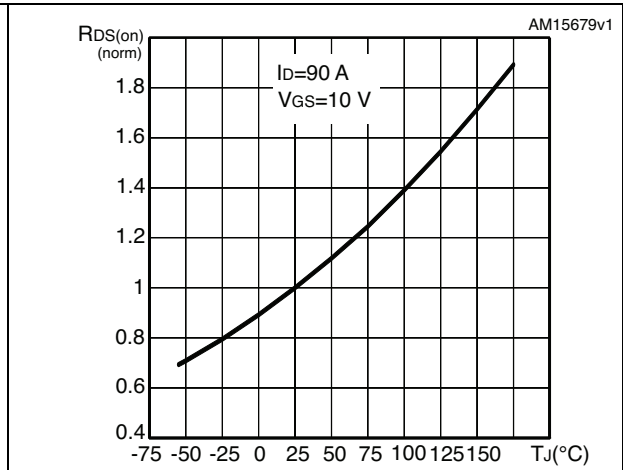
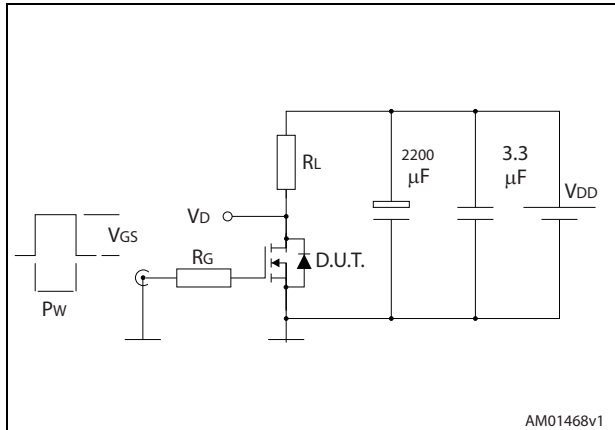

Figure 17. Normalized on-resistance vs temperature for TO-220



# 4 Test circuits

**Figure 18. Switching times test circuit for resistive load**



**Figure 19. Gate charge test circuit**

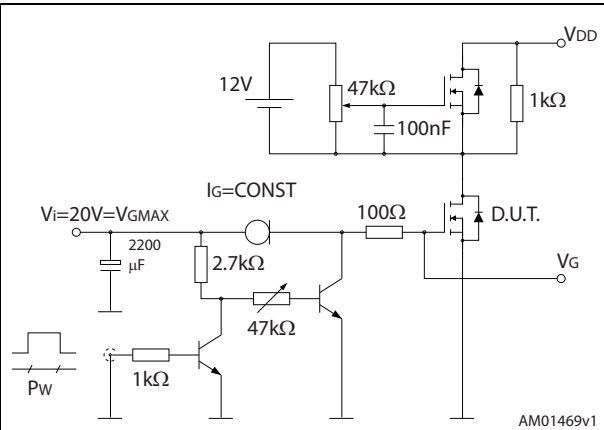

**Figure 20. Test circuit for inductive load switching and diode recovery times**

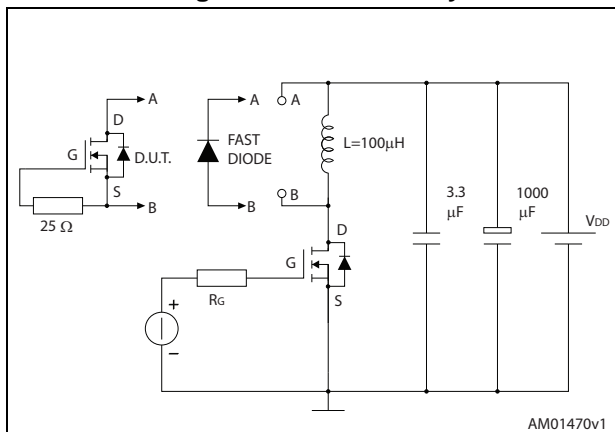

**Figure 21. Unclamped inductive load test circuit**

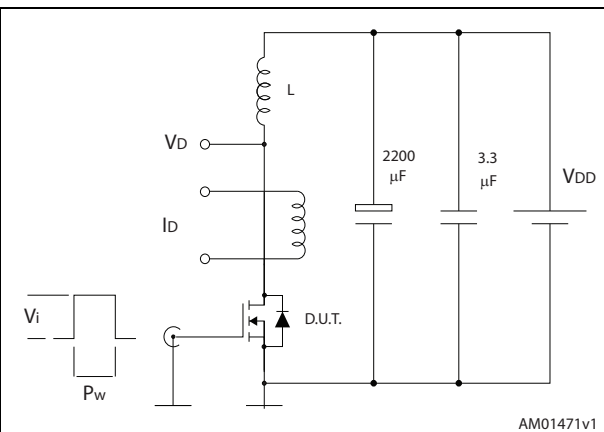

**Figure 22. Unclamped inductive waveform**

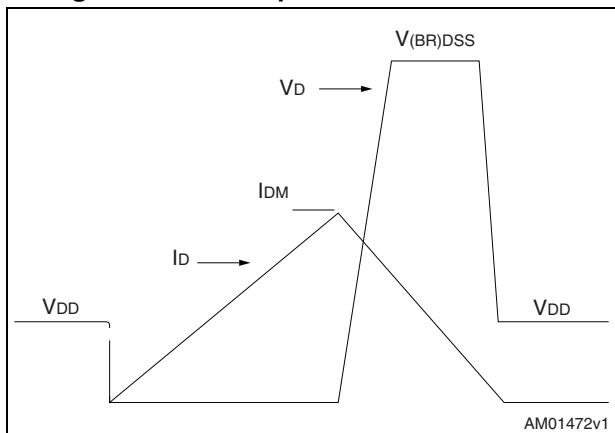

**Figure 23. Switching time waveform**

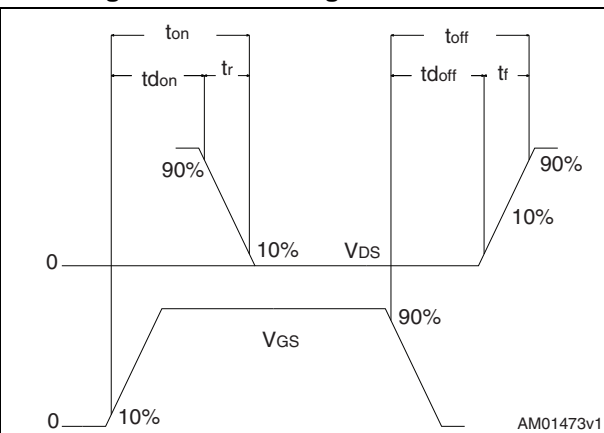

## 5 Package information

In order to meet environmental requirements, ST offers these devices in different grades of ECOPACK<sup>®</sup> packages, depending on their level of environmental compliance. ECOPACK<sup>®</sup> specifications, grade definitions and product status are available at: [www.st.com](http://www.st.com). ECOPACK<sup>®</sup> is an ST trademark.

### 5.1 H<sup>2</sup>PAK-2 package information

Figure 24. H<sup>2</sup>PAK-2 package information

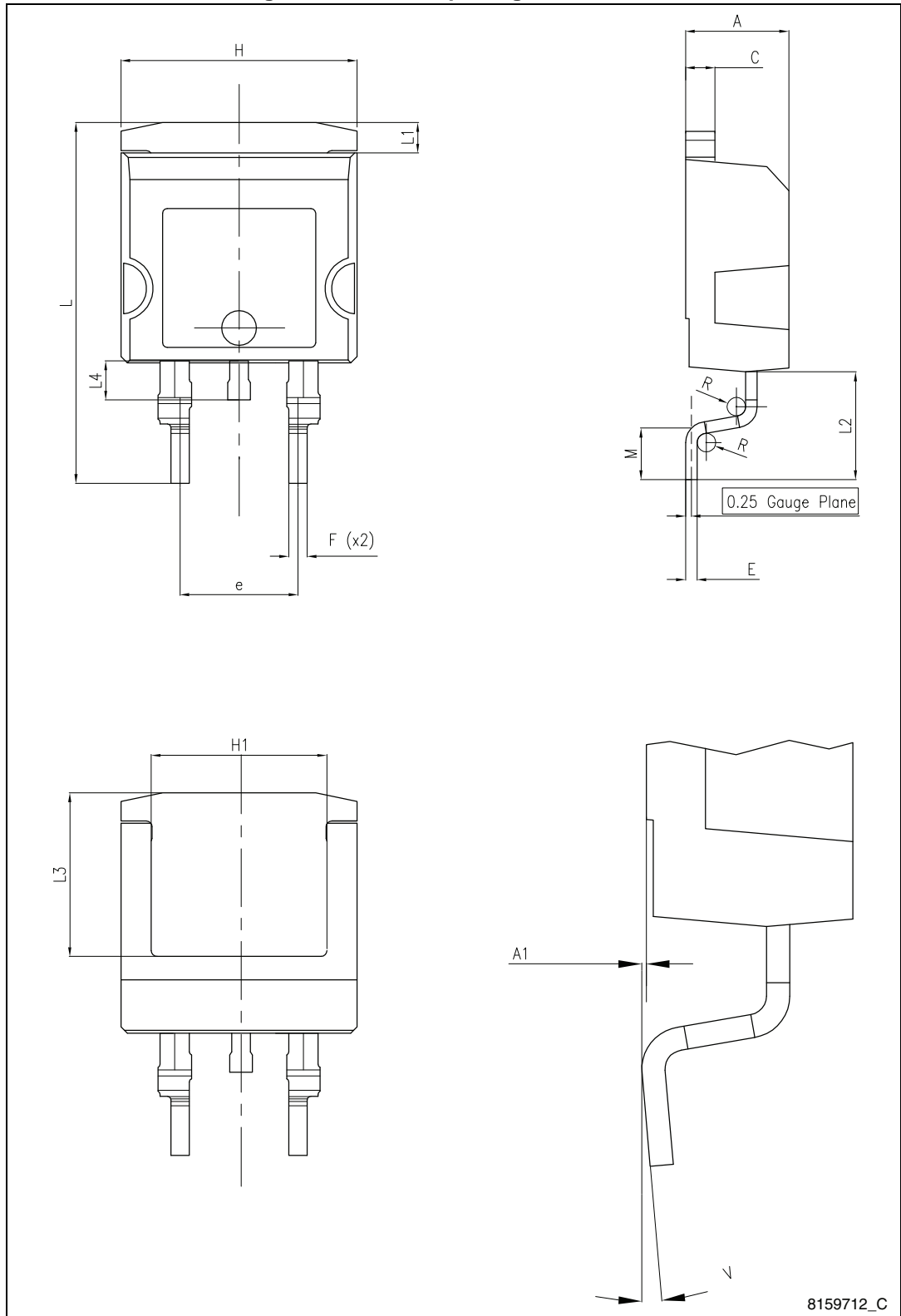
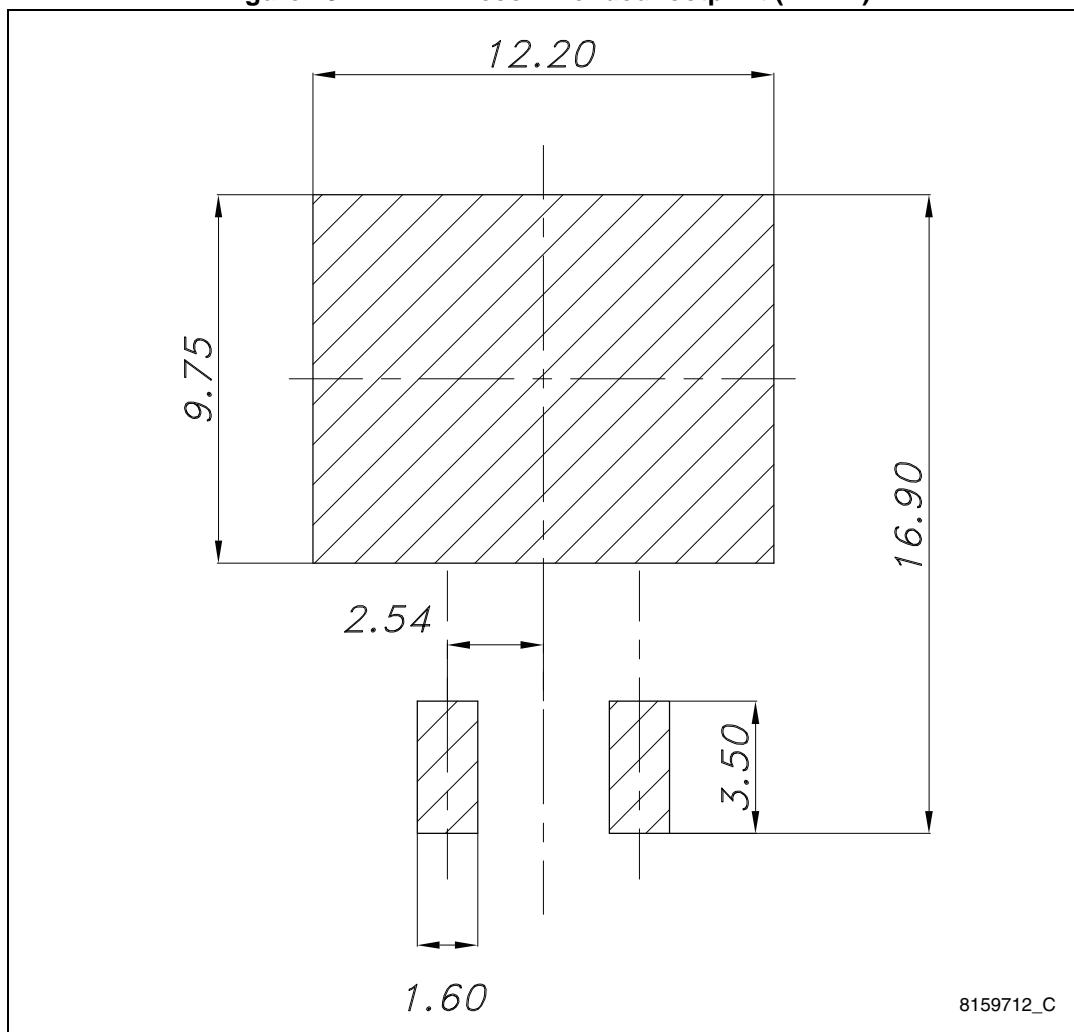

Table 8. H<sup>2</sup>PAK-2 package mechanical data

Dim.	mm		
	Min.	Typ.	Max.
A	4.30		4.80
A1	0.03		0.20
C	1.17		1.37
e	4.98		5.18
E	0.50		0.90
F	0.78		0.85
H	10.00		10.40
H1	7.40		7.80
L	15.30		15.80
L1	1.27		1.40
L2	4.93		5.23
L3	6.85		7.25
L4	1.5		1.7
M	2.6		2.9
R	0.20		0.60
V	0°		8°

Figure 25. H<sup>2</sup>PAK-2 recommended footprint (in mm)



## 5.2 H<sup>2</sup>PAK-6 package information

Figure 26. H<sup>2</sup>PAK-6 package outline

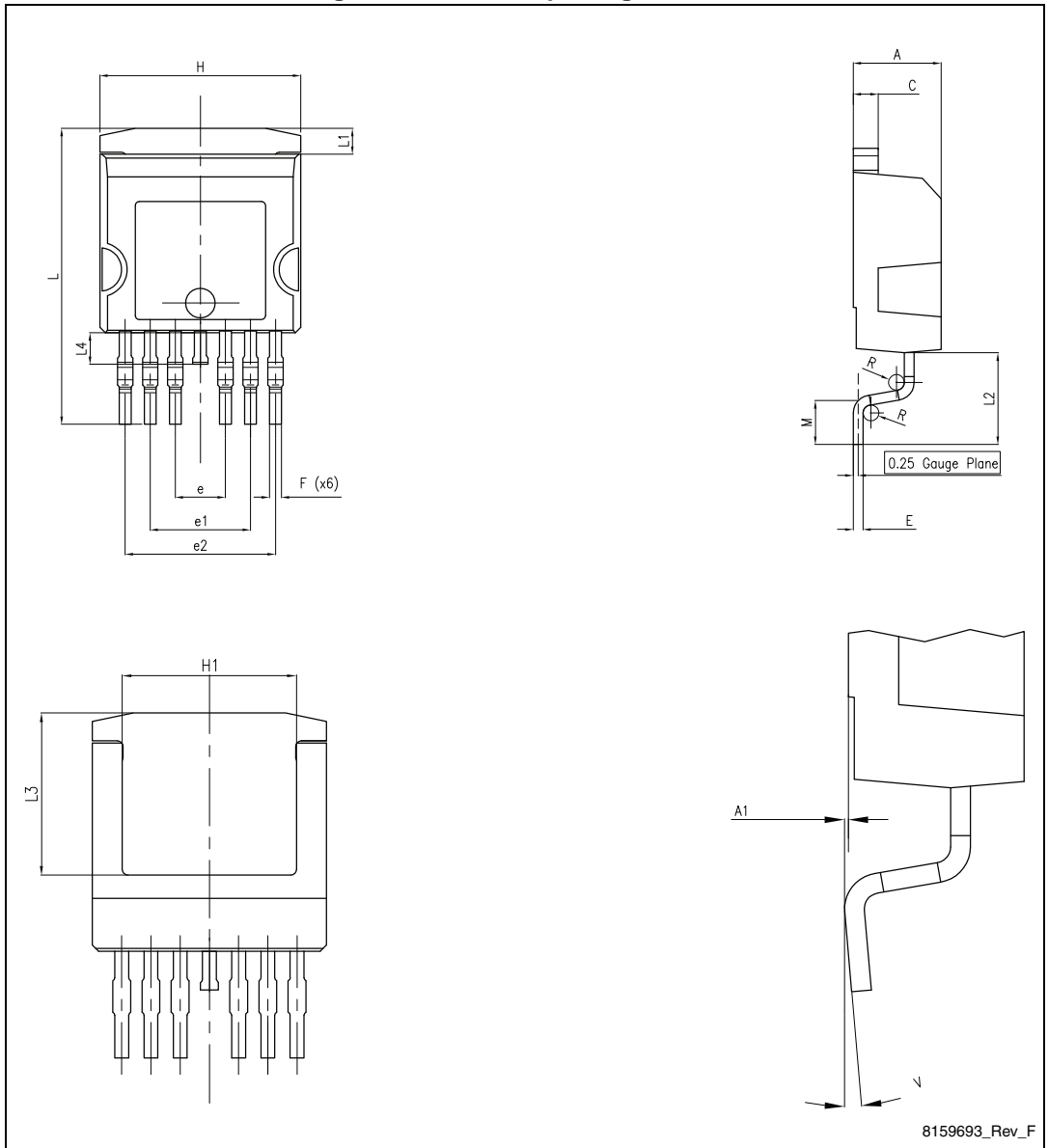

8159693\_Rev\_F

Table 9. H<sup>2</sup>PAK-6 package mechanical data

Dim.	mm		
	Min.	Typ.	Max.
A	4.30		4.80
A1	0.03		0.20
C	1.17		1.37
e	2.34		2.74
e1	4.88		5.28
e2	7.42		7.82
E	0.45		0.60
F	0.50		0.70
H	10.00		10.40
H1	7.40		7.80
L	14.75		15.25
L1	1.27		1.40
L2	4.35		4.95
L3	6.85		7.25
L4	1.5		1.75
M	1.90		2.50
R	0.20		0.60
V	0°		8°

Figure 27. H<sup>2</sup>PAK-6 recommended footprint (dimensions are in mm)

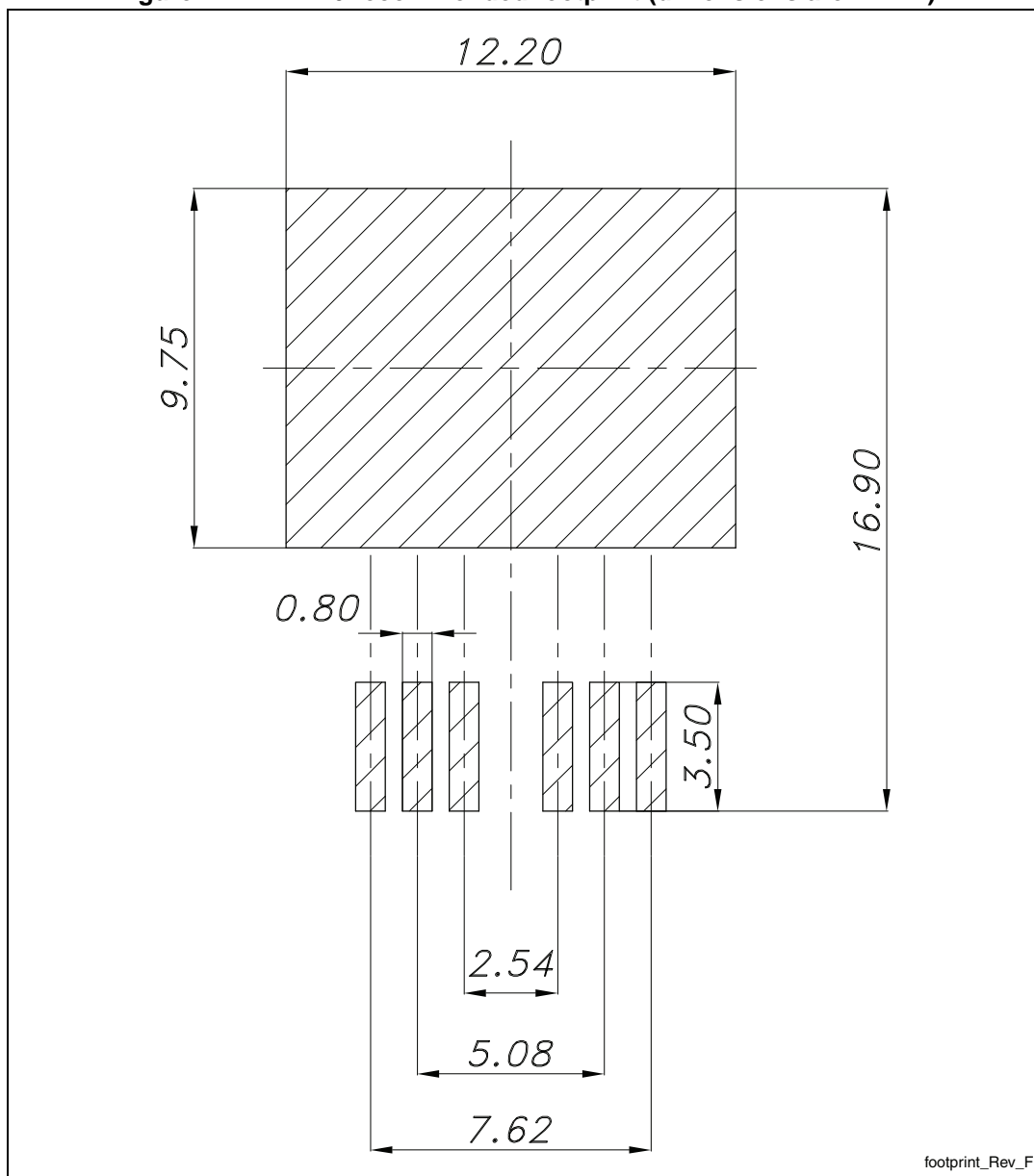

### 5.3 TO-220 type A package information

Figure 28. TO-220 type A package outline

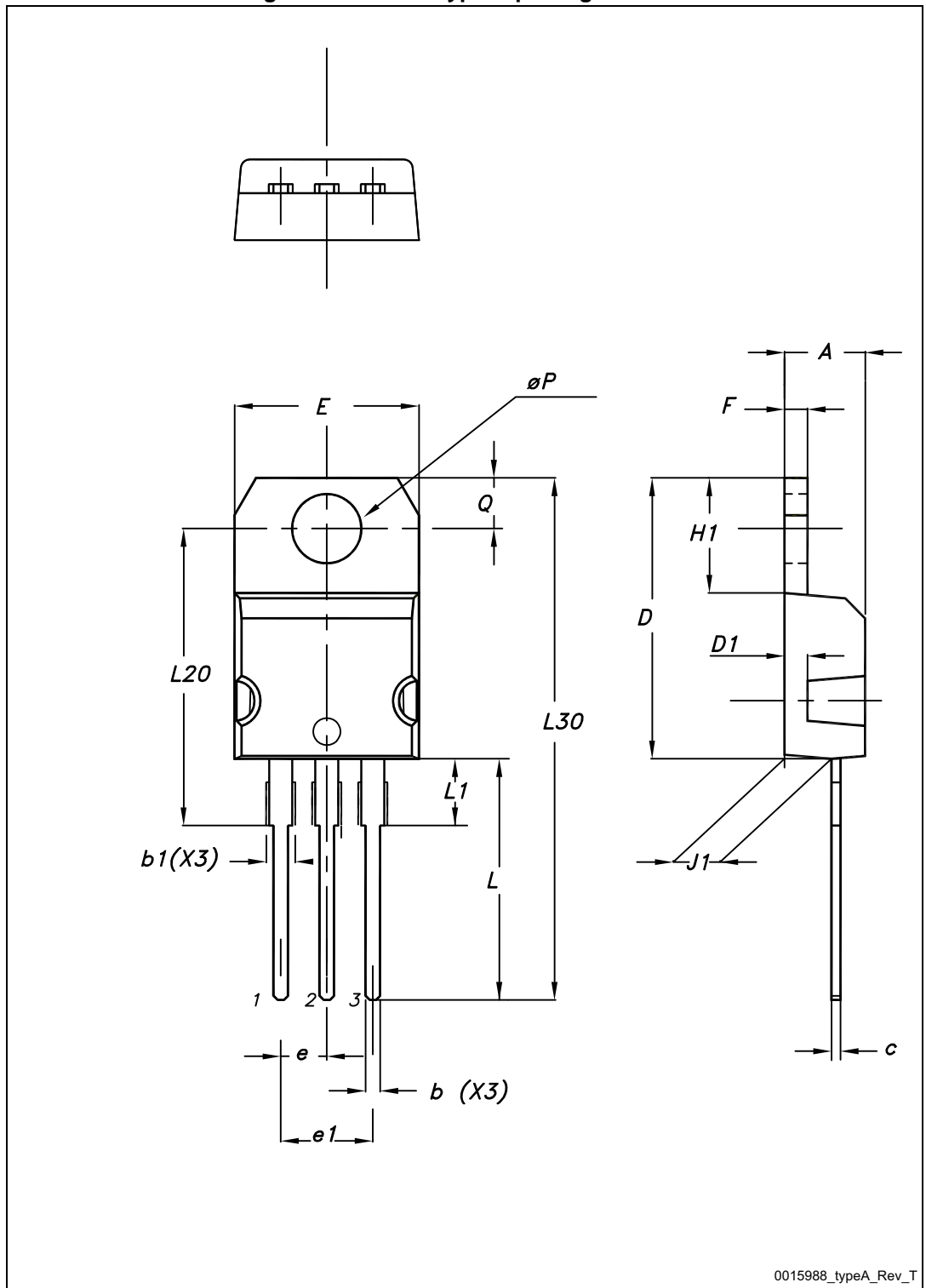

Table 10. TO-220 type A mechanical data

Dim.	mm		
	Min.	Typ.	Max.
A	4.40		4.60
b	0.61		0.88
b1	1.14		1.70
c	0.48		0.70
D	15.25		15.75
D1		1.27	
E	10		10.40
e	2.40		2.70
e1	4.95		5.15
F	1.23		1.32
H1	6.20		6.60
J1	2.40		2.72
L	13		14
L1	3.50		3.93
L20		16.40	
L30		28.90	
ØP	3.75		3.85
Q	2.65		2.95

# 6 Packing information

Figure 29. Tape

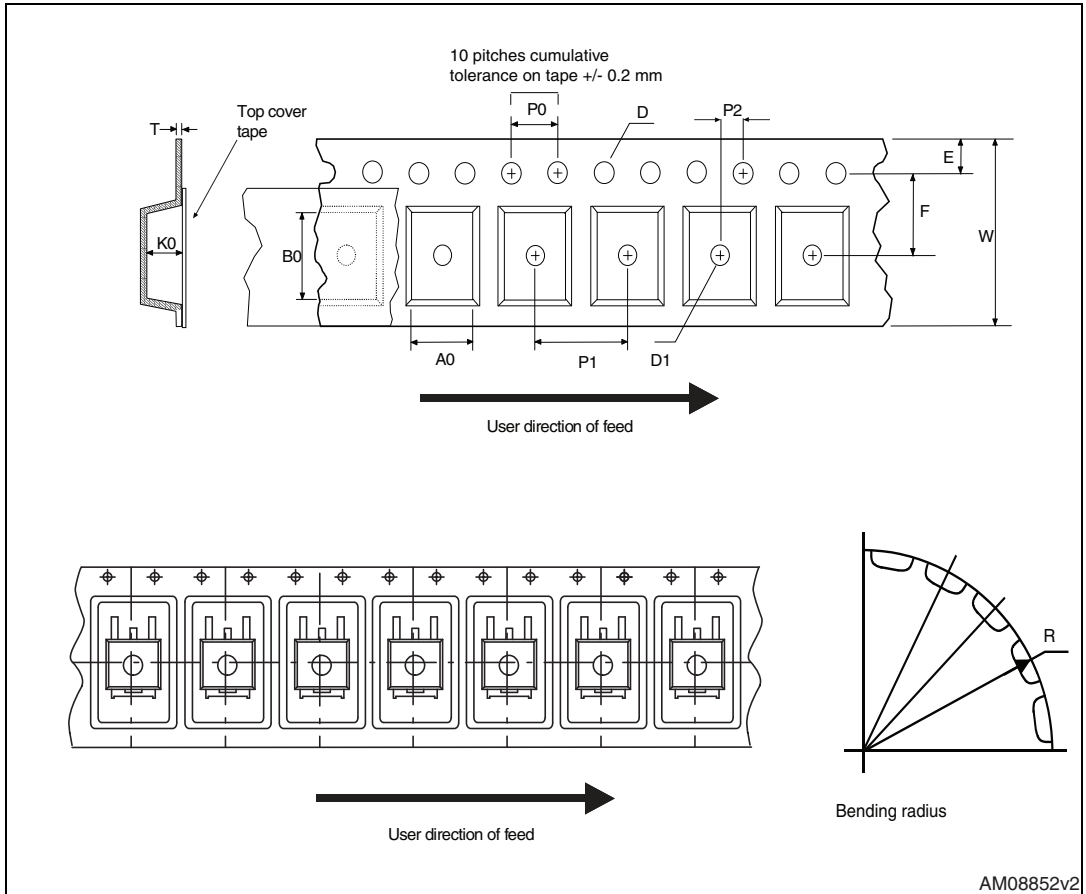

Figure 30. Reel

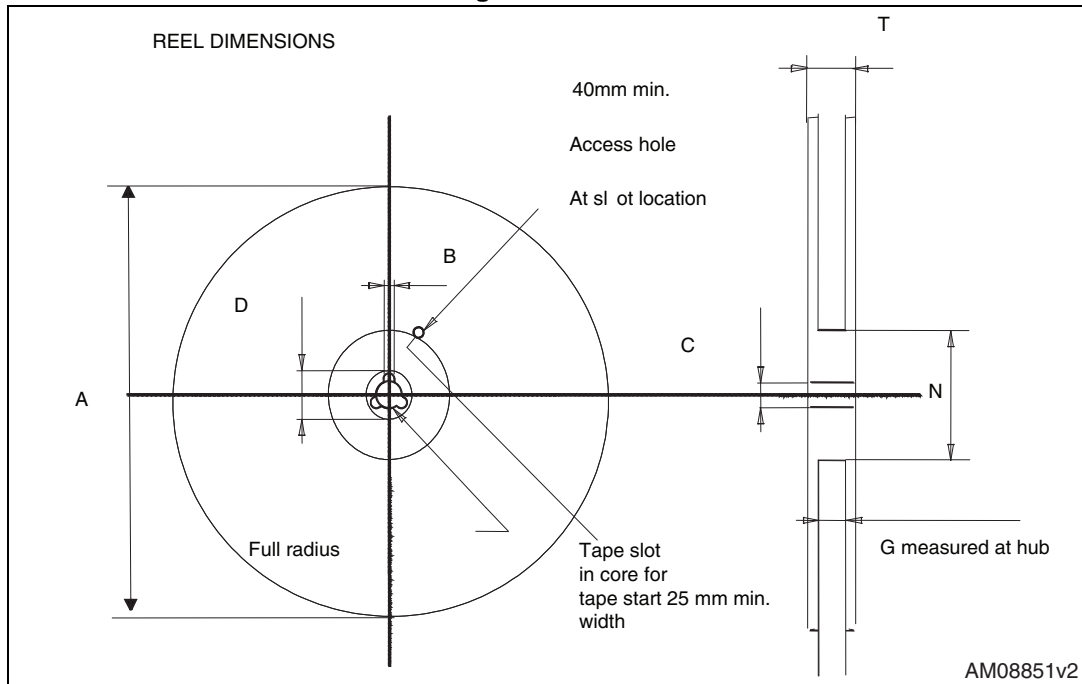

Table 11. H<sup>2</sup>PAK-2 and H<sup>2</sup>PAK-6 tape and reel mechanical data

Tape			Reel		
Dim.	mm		Dim.	mm	
	Min.	Max.		Min.	Max.
A0	10.5	10.7	A		330
B0	15.7	15.9	B	1.5	
D	1.5	1.6	C	12.8	13.2
D1	1.59	1.61	D	20.2	
E	1.65	1.85	G	24.4	26.4
F	11.4	11.6	N	100	
K0	4.8	5.0	T		30.4
P0	3.9	4.1			
P1	11.9	12.1		Base qty	1000
P2	1.9	2.1		Bulk qty	1000
R	50				
T	0.25	0.35			
W	23.7	24.3			

## 7 Revision history

**Table 12. Document revision history**

Date	Revision	Changes
03-Dec-2012	1	First release.
09-Apr-2013	2	<ul style="list-style-type: none"> <li>– Modified: <math>R_{DS(on)}</math> max values on <a href="#">Features</a> table, <math>I_{DSS}</math>, <math>I_{GSS}</math> values on <a href="#">Table 4</a>, <math>R_{DS(on)}</math> value for H<sup>2</sup>PAK-2, the entire typical values on <a href="#">Table 5</a> and <a href="#">6</a>, <math>V_{SD}</math> test conditions and max values, <math>T_{RR}</math>, <math>Q_{RR}</math>, <math>I_{RRM}</math> typical values on <a href="#">Table 7</a></li> <li>– Inserted: <a href="#">Section 3: Electrical characteristics (curves)</a></li> <li>– Document status promoted to preliminary data to production data</li> <li>– Added: H<sup>2</sup>PAK-6 package</li> <li>– Minor text changes</li> </ul>
11-Oct-2013	3	<ul style="list-style-type: none"> <li>– Modified: <math>C_{rSS}</math> typical value in <a href="#">Table 5</a></li> <li>– Updated: <a href="#">Section 5: Package information</a></li> <li>– Updated: <a href="#">Figure 18</a>, <a href="#">19</a>, <a href="#">20</a> and <a href="#">21</a></li> <li>– Minor text changes</li> </ul>
14-May-2015	4	<ul style="list-style-type: none"> <li>– Updated title, features and description in cover page.</li> <li>– Minor text changes</li> </ul>

**IMPORTANT NOTICE – PLEASE READ CAREFULLY**

STMicroelectronics NV and its subsidiaries ("ST") reserve the right to make changes, corrections, enhancements, modifications, and improvements to ST products and/or to this document at any time without notice. Purchasers should obtain the latest relevant information on ST products before placing orders. ST products are sold pursuant to ST's terms and conditions of sale in place at the time of order acknowledgement.

Purchasers are solely responsible for the choice, selection, and use of ST products and ST assumes no liability for application assistance or the design of Purchasers' products.

No license, express or implied, to any intellectual property right is granted by ST herein.

Resale of ST products with provisions different from the information set forth herein shall void any warranty granted by ST for such product.

ST and the ST logo are trademarks of ST. All other product or service names are the property of their respective owners.

Information in this document supersedes and replaces information previously supplied in any prior versions of this document.

© 2015 STMicroelectronics – All rights reserved

Компания «Life Electronics» занимается поставками электронных компонентов импортного и отечественного производства от производителей и со складов крупных дистрибьюторов Европы, Америки и Азии.

С конца 2013 года компания активно расширяет линейку поставок компонентов по направлению коаксиальный кабель, кварцевые генераторы и конденсаторы (керамические, пленочные, электролитические), за счёт заключения дистрибьюторских договоров

Мы предлагаем:

- Конкурентоспособные цены и скидки постоянным клиентам.
- Специальные условия для постоянных клиентов.
- Подбор аналогов.
- Поставку компонентов в любых объемах, удовлетворяющих вашим потребностям.
- Приемлемые сроки поставки, возможна ускоренная поставка.
- Доставку товара в любую точку России и стран СНГ.
- Комплексную поставку.
- Работу по проектам и поставку образцов.
- Формирование склада под заказчика.
- Сертификаты соответствия на поставляемую продукцию (по желанию клиента).
- Тестирование поставляемой продукции.
- Поставку компонентов, требующих военную и космическую приемку.
- Входной контроль качества.
- Наличие сертификата ISO.

В составе нашей компании организован Конструкторский отдел, призванный помогать разработчикам, и инженерам.

Конструкторский отдел помогает осуществить:

- Регистрацию проекта у производителя компонентов.
- Техническую поддержку проекта.
- Защиту от снятия компонента с производства.
- Оценку стоимости проекта по компонентам.
- Изготовление тестовой платы монтаж и пусконаладочные работы.



Тел: +7 (812) 336 43 04 (многоканальный)

Email: [org@lifeelectronics.ru](mailto:org@lifeelectronics.ru)