

LCD-MODULE 2x16 - 6.68mm INCL. CONTROLLER HD44780

no mounting
required



EA DIP162J-DN3LW
75 x 27 x 11 mm

EA DIP162-DN3LW
75 x 27 x 11 mm



EA DIP162-DHNLED
68 x 27 x 11 mm

FEATURES

- * HIGH CONTRAST LCD SUPERTWIST DISPLAY
- * EA DIP162-DNLED: YELLOW/GREEN WITH LED BACKLIGHT
- * EA DIP162-DN3LW AND DIP162J-DN3LW WITH WHITE LED B/L., LOW POWER
- * INCL. HD 44780 OR COMPATIBLE CONTROLLER
- * INTERFACE FOR 4- AND 8-BIT DATA BUS
- * POWER SUPPLY +5V OR $\pm 2.7V$ OR $\pm 3.3V$
- * OPERATING TEMPERATURE $0\sim+50^{\circ}C$ (-DN3LW, -DHNLED: $-20\sim+70^{\circ}C$)
- * LED BACKLIGHT Y/G max. 150mA@+25°C
- * LED BACKLIGHT WHITE max. 45mA@+25°C
- * SOME MORE MODULES WITH SAME MECHANIC AND SAME PINOUT:
 - DOTMATRIX 1x8, 4x20
 - GRAPHIC 122x32
- * NO SCREWS REQUIRED: SOLDER ON IN PCB ONLY
- * DETACHABLE VIA 9-PIN SOCKET EA B200-9 (2 PCS. REQUIRED)

ORDERING INFORMATION

LCD MODULE 2x16 - 6.68mm WITH BACKLIGHT Y/G
 SAME BUT WITH T_{OP.} -20..+70°C INCL. TEMP. COMPENSATION
 SAME IN BLUE-WHITE OPTIC, T_{OP.} -20..+70°C INCL. TEMP. COMP.
 SAME IN BLACK&WHITE, T_{OP.} -20..+70°C INCL. TEMP. COMP.
 9-PIN SOCKET, HEIGHT 4.3mm (1 PC.)
 SUITABLE BEZEL (WINDOW 60.0x14.8 mm)
 ADAPTOR PCB WITH STANDARD PINOUT PITCH 2.54mm

EA DIP162-DNLED
 EA DIP162-DHNLED
 EA DIP162-DN3LW
 EA DIP162J-DN3LW
 EA B200-9
 EA 017-2UKE
 EA 9907-DIP

**ELECTRONIC
ASSEMBLY**
making things easy

Pinout

Pin	Symbol	Level	Function	Pin	Symbol	Level	Function
1	VSS	L	Power Supply 0V (GND)	10	D3	H / L	Display Data
2	VDD	H	Power Supply +5V	11	D4 (D0)	H / L	Display Data
3	VEE	-	Contrast adjust. (about 0V)	12	D5 (D1)	H / L	Display Data
4	RS	H / L	H=Command, L=Data	13	D6 (D2)	H / L	Display Data
5	R/W	H / L	H=Read, L=Write	14	D7 (D3)	H / L	Display Data, MSB
6	E	H	Enable (falling edge)	15	-	-	NC (see EA DIP122-5N)
7	D0	H / L	Display Data, LSB	16	-	-	NC (see EA DIP122-5N)
8	D1	H / L	Display Data	17	A	-	LED B/L+ Resistor required
9	D2	H / L	Display Data	18	C	-	LED B/L -

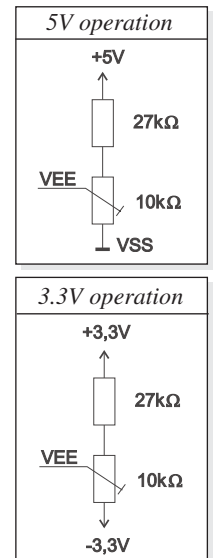

Contrast Adjustment

Contrast voltage for all displays of EA DIP162-D series is typ. 5V. That means that for 3.3V operation an additional negative voltage of min. 1.7V is required.

Display modules for -20..+70°C are equipped with an on-board temperature compensation. So there's no more need for contrast adjustment while operation anymore.

Backlight

Using the LED backlight requires an current source or external current-limiting resistor. Forward voltage for yellow/green backlight is 3.9~4.2V and for white LED backlight 3.0~3.6V. Please take care of derating for $T_a > +25^\circ\text{C}$

Note: Do never drive backlight direct to 5V; immediately damage my happen !

Character set

Character set shown below is already built in. In addition to that you are able to define up to 8 characters by yourself.

Lower 4 bit	Upper 4 bit	0000 (\$0x)	0010 (\$2x)	0011 (\$3x)	0100 (\$4x)	0101 (\$5x)	0110 (\$6x)	0111 (\$7x)	1010 (\$Ax)	1011 (\$Bx)	1100 (\$Cx)	1101 (\$Dx)	1110 (\$Ex)	1111 (\$Fx)
xxxx0000 (\$x0)	CG RAM (0)		0	1	P	~	P		-	9	3	4	u	p
xxxx0001 (\$x1)	(1)	!	1	A	Q	a	4		.	7	7	4	ä	q
xxxx0010 (\$x2)	(2)	"	2	B	R	b	r		r	i	u	x	p	0
xxxx0011 (\$x3)	(3)	#	3	C	S	c	s		j	u	t	e	e	w
xxxx0100 (\$x4)	(4)	\$	4	D	T	d	t		\	I	t	f	h	o
xxxx0101 (\$x5)	(5)	%	5	E	U	e	u		.	o	a	u	c	ü
xxxx0110 (\$x6)	(6)	&	6	F	V	f	v		7	o	o	o	p	z
xxxx0111 (\$x7)	(7)	'	7	G	W	g	w		7	k	7	7	g	π
xxxx1000 (\$x8)	CG RAM (0)	(8	H	X	h	x		i	o	7	u	r	7
xxxx1001 (\$x9)	(1))	9	I	Y	i	y		o	7	u	u	'	y
xxxx1010 (\$xA)	(2)	*	:	J	Z	j	z		e	o	n	o	j	7
xxxx1011 (\$xB)	(3)	+	;	K	[k	[o	7	o	o	*	7
xxxx1100 (\$xC)	(4)	,	<	L	¥	l	l		7	7	7	7	7	7
xxxx1101 (\$xD)	(5)	-	=	M	J	m	7		u	7	7	7	7	7
xxxx1110 (\$xE)	(6)	.	>	N	^	n	7		o	7	7	7	7	7
xxxx1111 (\$xF)	(7)	/	?	O	_	o	7		7	7	7	7	7	7

Table of command

Instruction	Code										Description	Execute Time (max.)
	RS	R/W	DB 7	DB 6	DB 5	DB 4	DB 3	DB 2	DB 1	DB 0		
Clear Display	0	0	0	0	0	0	0	0	0	1	Clears all display and returns the cursor to the home position (Address 0).	1.64ms
Cursor At Home	0	0	0	0	0	0	0	0	1	*	Returns the Cursor to the home position (Address 0). Also returns the display being shifted to the original position. DD RAM contents remain unchanged.	1.64ms
Entry Mode Set	0	0	0	0	0	0	0	1	I/D	S	Sets the Cursor move direction and specifies or not to shift the display. These operation are performed during data write and read.	40µs
Display On/Off Control	0	0	0	0	0	0	1	D	C	B	Sets ON/OFF of all display (D) cursor ON/OFF (C), and blink of cursor position character (B).	40µs
Cursor / Display Shift	0	0	0	0	0	1	S/C	R/L	*	*	Moves the Cursor and shifts the display without changing DD RAM contents.	40µs
Function Set	0	0	0	0	1	DL	N	F	*	*	Sets interface data length (DL) number of display lines (L) and character font (F).	40µs
CG RAM Address Set	0	0	0	1	ACG					Sets the CG RAM address. CG RAM data is sent and received after this setting.		40µs
DD RAM Address Set	0	0	1	ADD					Sets the DD RAM address. DD RAM data is sent and received after this setting.		40µs	
Busy Flag / Address Read	0	1	BF	AC					Reads Busy flag (BF) indicating internal operation is being performed and reads address counter contents.		-	
CG RAM / DD RAM Data write	1	0	Write Data					Writes data into DD RAM or CG RAM		40µs		
CG RAM / DD RAM Data Read	1	1	Read Data					Reads data from DD RAM or CG RAM		40µs		

Creating your own characters

All these character display modules got the feature to create 8 own characters (ASCII Codes 0..7) in addition to the 192 ROM fixed codes.

- 1.) The command "CG RAM Address Set" defines the ASCII code (Bit 3,4,5) and the dot line (Bit 0,1,2) of the new character. Example demonstrates creating ASCII code \$00.
- 2.) Doing 8 times the write command "Data Write" defines line by line the new character. 8th. byte stands for the cursor line.
- 3.) The new defined character can be used as a "normal" ASCII code (0..7); use with "DD RAM Address Set" and "Data Write".

Set CG RAM Address		Data
Adresse	Hex	
0 1 0 0 0	\$40	
	\$41	
	\$42	
	\$43	
	\$44	
	\$45	
	\$46	
	\$47	

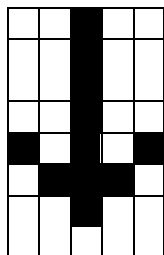

Data								Hex
Bit								
7	6	5	4	3	2	1	0	Hex
0	0	1	0	0	0	0	\$04	
0	0	1	0	0	0	0	\$04	
0	0	1	0	0	0	0	\$04	
0	0	1	0	0	0	0	\$04	
1	0	1	0	1	0	1	\$15	
0	1	1	1	1	0	0	\$0E	
0	0	1	0	0	0	0	\$04	
0	0	0	0	0	0	0	\$00	

INITIALISATION FOR A 2 LINE DISPLAY / 8-BIT MODE

Command	RS	R/W	DB7	DB6	DB5	DB4	DB3	DB2	DB1	DB0	Remark
Function Set	0	0	0	0	1	1	1	0	0	0	8-Bit Data Length, 2/4 lines, 5x7 Font
Display ON/OFF	0	0	0	0	0	0	1	1	1	1	Display on, Cursor visible, Cursor blink
Clear Display	0	0	0	0	0	0	0	0	0	1	Clear Display, Cursor Home
Entry Mode Set	0	0	0	0	0	0	0	1	1	0	Cursor Auto-Increment

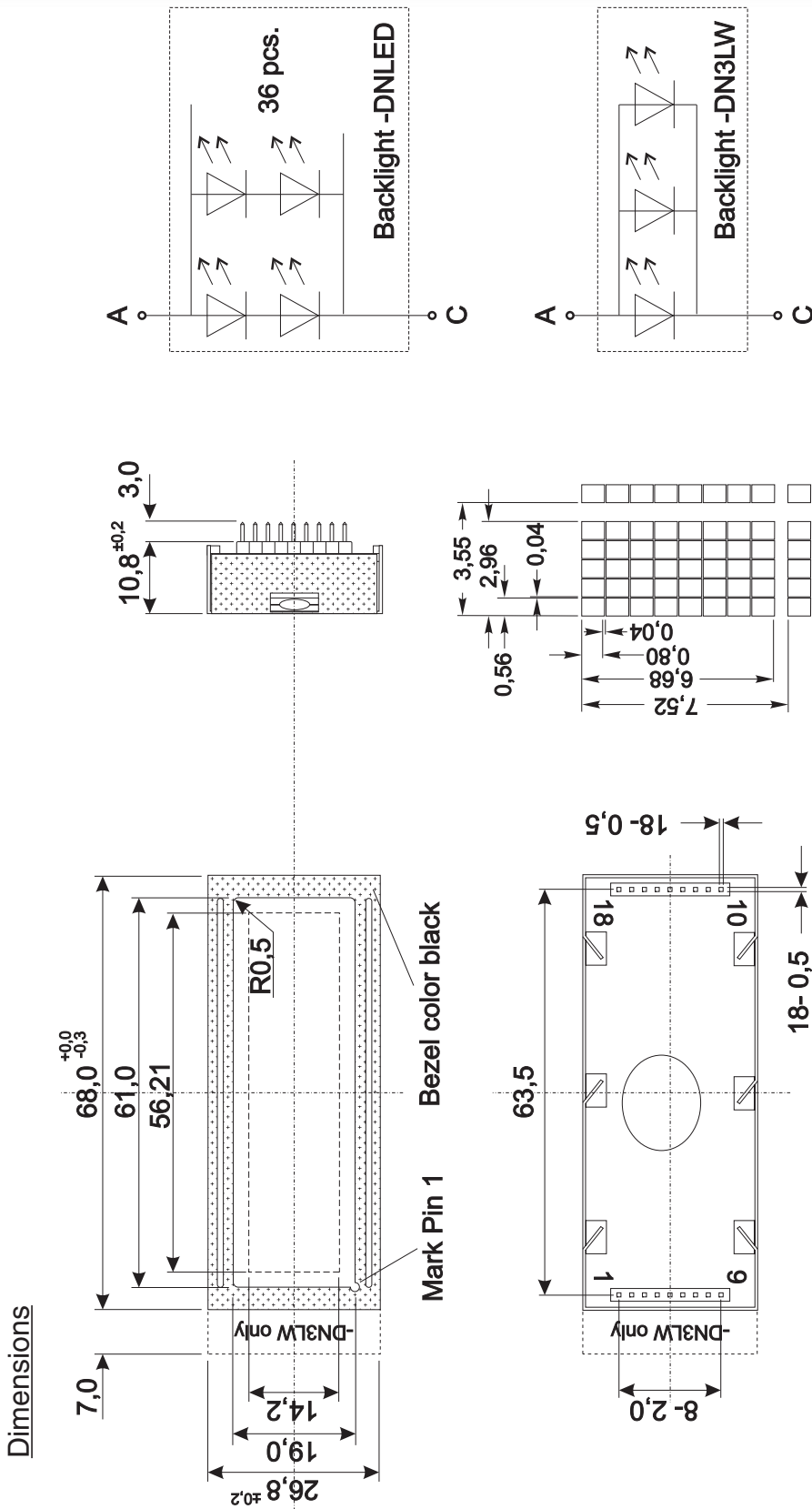

all dimensions are in mm



Test board for standard pinout 2.54mm
EA 9907-DIP

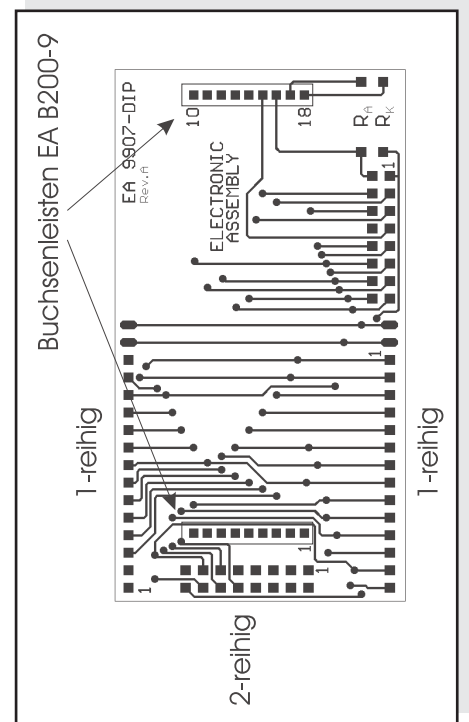

Компания «Life Electronics» занимается поставками электронных компонентов импортного и отечественного производства от производителей и со складов крупных дистрибьюторов Европы, Америки и Азии.

С конца 2013 года компания активно расширяет линейку поставок компонентов по направлению коаксиальный кабель, кварцевые генераторы и конденсаторы (керамические, пленочные, электролитические), за счёт заключения дистрибьюторских договоров

Мы предлагаем:

- Конкурентоспособные цены и скидки постоянным клиентам.
- Специальные условия для постоянных клиентов.
- Подбор аналогов.
- Поставку компонентов в любых объемах, удовлетворяющих вашим потребностям.
- Приемлемые сроки поставки, возможна ускоренная поставка.
- Доставку товара в любую точку России и стран СНГ.
- Комплексную поставку.
- Работу по проектам и поставку образцов.
- Формирование склада под заказчика.
- Сертификаты соответствия на поставляемую продукцию (по желанию клиента).
- Тестирование поставляемой продукции.
- Поставку компонентов, требующих военную и космическую приемку.
- Входной контроль качества.
- Наличие сертификата ISO.

В составе нашей компании организован Конструкторский отдел, призванный помогать разработчикам, и инженерам.

Конструкторский отдел помогает осуществить:

- Регистрацию проекта у производителя компонентов.
- Техническую поддержку проекта.
- Защиту от снятия компонента с производства.
- Оценку стоимости проекта по компонентам.
- Изготовление тестовой платы монтаж и пусконаладочные работы.



Тел: +7 (812) 336 43 04 (многоканальный)

Email: org@lifeelectronics.ru