

Ultra Low Current XO 10 MHz to 52 MHz

FEATURES

- Low phase noise (-130 dBc @ 10kHz offset).
- CMOS output with OE tri-state control.
- Selectable oscillator “on” or “off” (Sleep Mode) feature in output disable mode
- Ultra Low current consumption (<2mA, <1.5mA at 27MHz, 3.3V respectively for PLL600-27 and PLL600-37)
- Ultra Low disable mode current (<2uA when disabled with osc. off)
- 10 to 52MHz fundamental or 3rd OT crystal input.
- 12mA drive capability at TTL output.
- Low jitter (RMS): 2.5ps period jitter.
- 1.8V, 2.5V and 3.3V DC operation.
- Available in 8 pin SOIC, 6 pin SOT or DIE.

DESCRIPTION

The PLL600-27/-37 form a low cost family of XO IC’s, designed to consume the lowest current on the market for the 10MHz to 52MHz range. It accepts fundamental resonant mode crystal input from 10 to 52MHz. Providing less than -130dBc at 10kHz offset at 30MHz and with a very low jitter (2.5 ps RMS period jitter) makes this chip ideal for applications requiring low current frequency sources.

BLOCK DIAGRAM

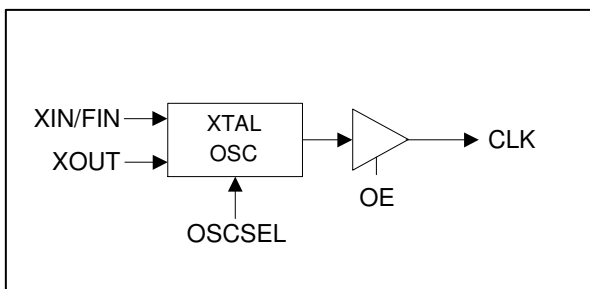

PIN ASSIGNMENT (PACKAGE)

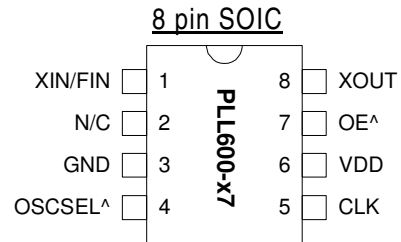

^ : denotes internal pull-up

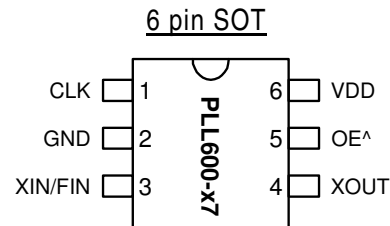

^: denotes internal Pull-up

SELECTION TABLE

OE^	OSCSEL^*	OUTPUT
0	0	Disabled - osc. off
0	1	Disabled - osc. on
1	0	Enabled
1	1	Enabled

^ Internal Pull-up, default value is ‘1’ when not connected.
* Not available in 6 pin SOT package.

Ultra Low Current XO 10 MHz to 52 MHz
PIN/PAD DESCRIPTION

Name	Pin #		Type	Description
	8 pin SOIC	6 pin SOT		
XIN	1	4	I	Crystal input or reference clock input pin.
N/C	2	n/a	I	No connect.
GND	3	2	P	Ground.
OSCSEL	4	n/a	I	Disable mode select. See Table on page 1.
CLK	5	1	O	Output clock.
VDD	6	6	P	Power supply.
OE	7	5	I	Output Enable input. See Table on page 1.
XOUT	8	3	I	Crystal output.

OE and OSCSEL have internal pull-ups, so the default value is '1' when not connected (OSCSEL not available on 6 pin package).

ELECTRICAL SPECIFICATIONS
1. Absolute Maximum Ratings

PARAMETERS	SYMBOL	MIN.	MAX.	UNITS
Supply Voltage	V_{DD}		4.6	V
Input Voltage, dc	V_I	-0.5	$V_{DD}+0.5$	V
Output Voltage, dc	V_O	-0.5	$V_{DD}+0.5$	V
Storage Temperature	T_S	-65	150	°C
Ambient Operating Temperature*	T_A	-40	85	°C
Junction Temperature	T_J		125	°C
Lead Temperature (soldering, 10s)			260	°C
ESD Protection, Human Body Model			2	kV

Exposure of the device under conditions beyond the limits specified by Maximum Ratings for extended periods may cause permanent damage to the device and affect product reliability. These conditions represent a stress rating only, and functional operations of the device at these or any other conditions above the operational limits noted in this specification is not implied.

* **Note:** Operating Temperature is guaranteed by design for all parts (COMMERCIAL and INDUSTRIAL), but tested for COMMERCIAL grade only.

2. AC Electrical Specifications

PARAMETERS	CONDITIONS	MIN.	TYP.	MAX.	UNITS
Input Crystal Frequency		10		52	MHz
Settling time	At power-up (Vdd reaches 1.62V)			10	ms
	Disable to enable, osc. Off			10	ms
	Disable to enable, osc. On			500	µs
Output Clock Rise/Fall Time	0.8V ~ 2.0V with 10 pF load		1.15		ns
	0.3V ~ 3.0V with 15 pF load		2.4		
VDD sensitivity	Frequency vs. VDD +/- 10%	0.8		0.8	ppm
Output Clock Duty Cycle	Measured @ 50% V_{DD}	45	50	55	%

Ultra Low Current XO 10 MHz to 52 MHz
3. Jitter and Phase Noise Specifications

PARAMETERS	CONDITIONS	MIN.	TYP.	MAX.	UNITS
RMS Period Jitter (1 sigma – 1000 samples)	With capacitive decoupling between VDD and GND.		2.1	2.5	ps
Phase Noise relative to carrier	30MHz @100Hz offset		-80		dBc/Hz
Phase Noise relative to carrier	30MHz @1kHz offset		-110		dBc/Hz
Phase Noise relative to carrier	30MHz @10kHz offset		-130		dBc/Hz
Phase Noise relative to carrier	30MHz @100kHz offset		-138		dBc/Hz
Phase Noise relative to carrier	30MHz @1MHz offset		-145		dBc/Hz

4. DC Specification

PARAMETERS	SYMBOL	CONDITIONS	MIN.	TYP.	MAX.	UNITS
Supply Current, Dynamic, with Loaded Outputs (at VDD = 3.3V) Respectively for PLL600 -27/-37	I _{DD}	At 10MHz, Cload=15pF		1.0 / 0.75	1.1 / 0.9	mA
		At 13.5MHz, Cload=15pF		1.2 / 0.8	1.3 / 1.0	
		At 17.7MHz, Cload=15pF		1.5 / 1.0	1.6 / 1.1	
		At 27MHz, Cload=15pF		2.0 / 1.2	2.1 / 1.3	
		At 48MHz, Cload=15pF		3.5 / 2.1	3.6 / 2.2	
Supply Current in tri- state	I _{DD}	Output disabled, Osc. off		2	4	μA
		Output disabled, Osc. On			520	μA
Operating Voltage	V _{DD}		1.62		3.63	V
Output High Voltage	V _{OH}	I _{OH} = -12mA* (3.3V)	2.4			V
		-37*, I _{OH} = -12mA* (3.3V)	2.4	2.9		V
Output Low Voltage	V _{OL}	I _{OL} = 12mA* (3.3V)			0.4	V
		-37*, I _{OL} = 12mA* (3.3V)		0.32	0.4	V
Output High Voltage at CMOS level (PLL600-27)	V _{OHC}	I _{OH} = -4mA	V _{DD} - 0.4			V
Output drive current (PLL600-27)		At TTL level (3.3V)	12	17		mA
Short Circuit Current		(3.3V)		±50		mA

* Note: PLL600-37 has non-standard CMOS VOH and VOL levels for lower current consumption, but meets CMOS input stage needs. PLL600-37 should be used to drive pure capacitive loads only.

5. Crystal Specifications

PARAMETERS	SYMBOL	MIN.	TYP.	MAX.	UNITS
Crystal Resonator Frequency	F _{XIN}	10		52	MHz
Crystal Loading Rating	C _{L(xtal)}		8.5		pF
Maximum Sustainable Drive Level				200	μW
Operating Drive Level			50		μW
C0 (for frequencies below 30MHz)				5	pF
C0 (for frequencies above 30MHz)				4	pF
ESR	R _s			30	Ω

Note: A detailed crystal specification document is also available for this part

Ultra Low Current XO 10 MHz to 52 MHz

PACKAGE INFORMATION

8-PIN SOIC (dimensions in mm)

Symbol	Narrow SOIC	
	Min.	Max.
A	1.47	1.73
A1	0.10	0.25
B	0.33	0.51
C	0.19	0.25
D	4.80	4.95
E	3.80	4.00
H	5.80	6.20
L	0.38	1.27
e	1.27 BSC	

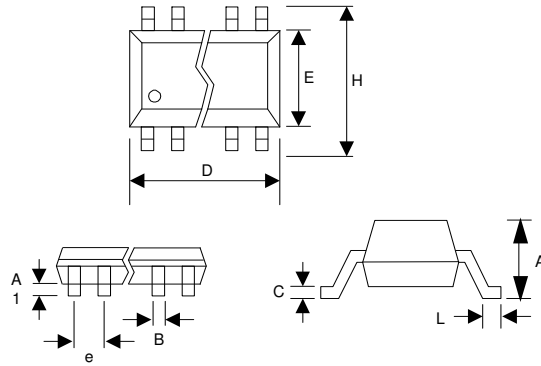

6-PIN SOIC (dimensions in mm)

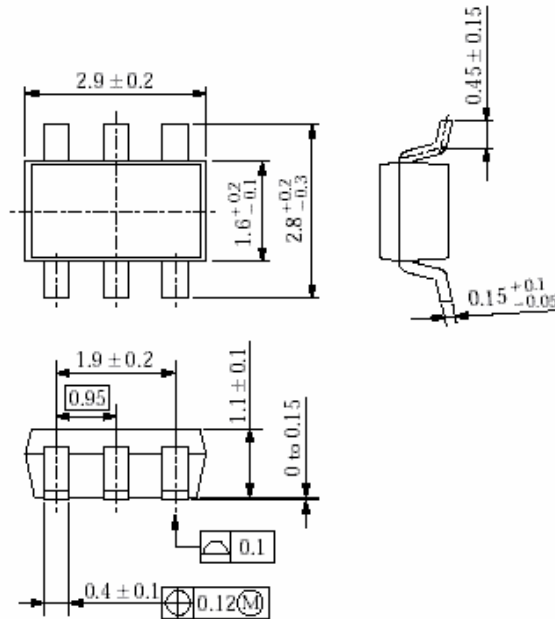

Ultra Low Current XO 10 MHz to 52 MHz

ORDERING INFORMATION

For part ordering, please contact our Sales Department:

47745 Fremont Blvd., Fremont, CA 94538, USA

Tel: (510) 492-0990 Fax: (510) 492-0991

PART NUMBER

The order number for this device is a combination of the following:
Device number, Package type and Operating temperature range

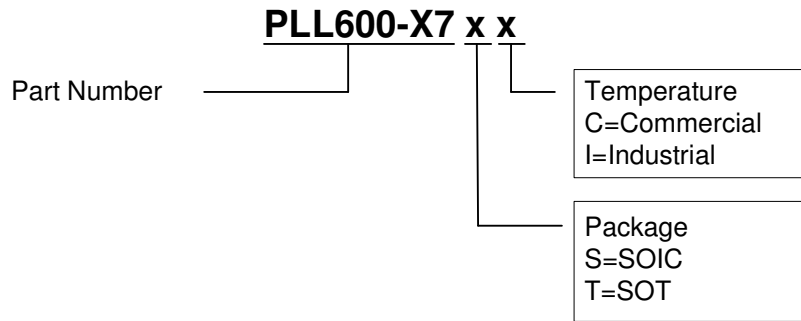

Order Number	Marking	Package Option
PLL600-27SC	P600-27 SC	8-Pin SOIC (Tube)
PLL600-27SC-R	P600-27 SC	8-Pin SOIC (Tape and Reel)
PLL600-27TC	A27A1	6-Pin SOT (Bulk)
PLL600-37SC	P600-37 SC	8-Pin SOIC (Tube)
PLL600-37SC-R	P600-37 SC	8-Pin SOIC (Tape and Reel)
PLL600-37TC	A37A2	6-Pin SOT (Bulk)

PhaseLink Corporation, reserves the right to make changes in its products or specifications, or both at any time without notice. The information furnished by PhaseLink is believed to be accurate and reliable. However, PhaseLink makes no guarantee or warranty concerning the accuracy of said information and shall not be responsible for any loss or damage of whatever nature resulting from the use of, or reliance upon this product.

LIFE SUPPORT POLICY: PhaseLink's products are not authorized for use as critical components in life support devices or systems without the express written approval of the President of PhaseLink Corporation.

Компания «Life Electronics» занимается поставками электронных компонентов импортного и отечественного производства от производителей и со складов крупных дистрибьюторов Европы, Америки и Азии.

С конца 2013 года компания активно расширяет линейку поставок компонентов по направлению коаксиальный кабель, кварцевые генераторы и конденсаторы (керамические, пленочные, электролитические), за счёт заключения дистрибьюторских договоров

Мы предлагаем:

- Конкурентоспособные цены и скидки постоянным клиентам.
- Специальные условия для постоянных клиентов.
- Подбор аналогов.
- Поставку компонентов в любых объемах, удовлетворяющих вашим потребностям.
- Приемлемые сроки поставки, возможна ускоренная поставка.
- Доставку товара в любую точку России и стран СНГ.
- Комплексную поставку.
- Работу по проектам и поставку образцов.
- Формирование склада под заказчика.
- Сертификаты соответствия на поставляемую продукцию (по желанию клиента).
- Тестирование поставляемой продукции.
- Поставку компонентов, требующих военную и космическую приемку.
- Входной контроль качества.
- Наличие сертификата ISO.

В составе нашей компании организован Конструкторский отдел, призванный помогать разработчикам, и инженерам.

Конструкторский отдел помогает осуществить:

- Регистрацию проекта у производителя компонентов.
- Техническую поддержку проекта.
- Защиту от снятия компонента с производства.
- Оценку стоимости проекта по компонентам.
- Изготовление тестовой платы монтаж и пусконаладочные работы.



Тел: +7 (812) 336 43 04 (многоканальный)

Email: org@lifeelectronics.ru