



**L-BAND 4 W SINGLE CONTROL HIGH POWER SPDT SWITCH**

**DESCRIPTION**

The  $\mu$ PG2156TB is an L-band single control SPDT GaAs FET switch which was developed for digital cellular or cordless telephone application. The device can operate from 800 MHz to 2.5 GHz, having the low insertion loss and high linearity.

**FEATURES**

- Low insertion loss : L<sub>INS</sub> = 0.45 dB TYP. @ V<sub>cont</sub> = +2.6 V/0 V, f = 1.0 GHz, IN-OUT1  
: L<sub>INS</sub> = 0.35 dB TYP. @ V<sub>cont</sub> = +2.6 V/0 V, f = 1.0 GHz, IN-OUT2  
: L<sub>INS</sub> = 0.45 dB TYP. @ V<sub>cont</sub> = +2.6 V/0 V, f = 2.0 GHz, IN-OUT1/2
- High power switching : P<sub>in(0.1 dB)</sub> = 37 dBm TYP. @ V<sub>cont</sub> = +2.6 V/0 V, f = 1.0 GHz, IN-OUT1/2
- 6-pin super minimold package (2.1 × 2.0 × 0.9 mm)

**APPLICATION**

- GSM Triple/Quad band digital cellular

**ORDERING INFORMATION**

Part Number	Order Number	Package	Marking	Supplying Form
$\mu$ PG2156TB-E4	$\mu$ PG2156TB-E4-A	6-pin super minimold (Pb-Free)	G4V	<ul style="list-style-type: none"><li>• Embossed tape 8 mm wide</li><li>• Pin 4, 5, 6 face the perforation side of the tape</li><li>• Qty 3 kpcs/reel</li></ul>

**Remark** To order evaluation samples, contact your nearby sales office.

Part number for sample order:  $\mu$ PG2156TB-A

**Caution: Observe precautions when handling because these devices are sensitive to electrostatic discharge**

The information in this document is subject to change without notice. Before using this document, please confirm that this is the latest version.

**PIN CONNECTIONS**

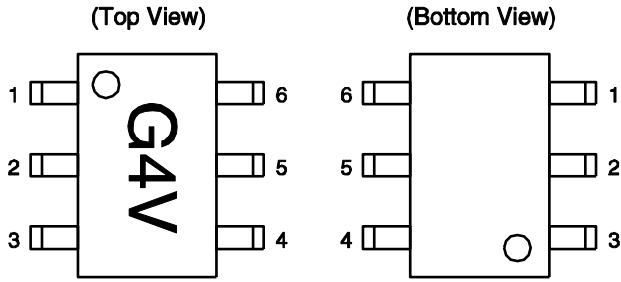

Pin No.	Pin Name
1	OUT2
2	GND
3	OUT1
4	V <sub>DD</sub>
5	IN
6	V <sub>cont</sub>

**ABSOLUTE MAXIMUM RATINGS (T<sub>A</sub> = +25°C)**

Parameter	Symbol	Ratings	Unit
Supply Voltage	V <sub>DD</sub>	+8.0	V
Control Voltage	V <sub>cont</sub>	+8.0	V
Input Power	P <sub>in</sub>	+38	dBm
Operating Ambient Temperature	T <sub>A</sub>	-45 to +85	°C
Storage Temperature	T <sub>stg</sub>	-55 to +150	°C

**RECOMMENDED OPERATING RANGE (T<sub>A</sub> = +25°C)**

Parameter	Symbol	MIN.	TYP.	MAX.	Unit
Supply Voltage	V <sub>DD</sub>	+2.4	+2.6	+5.0	V
Control Voltage (High)	V <sub>cont (H)</sub>	+2.4	+2.6	+5.0	V
Control Voltage (Low)	V <sub>cont (L)</sub>	0	0	+0.2	V

**ELECTRICAL CHARACTERISTICS (T<sub>A</sub> = +25°C, V<sub>DD</sub> = +2.6 V, V<sub>cont</sub> = +2.6 V/0 V, Z<sub>o</sub> = 50 Ω, off chip DC blocking capacitors value: 56 pF, unless otherwise specified)**

Parameter	Symbol	Test Conditions	Pass	MIN.	TYP.	MAX.	Unit
Insertion Loss	L <sub>INS</sub>	f = 0.8 to 1.0 GHz	IN-OUT1	–	0.45	0.65	dB
			IN-OUT2	–	0.35	0.55	dB
		f = 1.0 to 2.0 GHz	IN-OUT1/2	–	0.45	0.65	dB
		f = 2.0 to 2.5 GHz	IN-OUT1/2	–	0.50	–	dB
Isolation	ISL	f = 0.8 to 1.0 GHz	IN-OUT1/2	21.0	23.0	–	dB
		f = 1.0 to 2.0 GHz	IN-OUT1/2	15.5	17.5	–	dB
		f = 2.0 to 2.5 GHz	IN-OUT1/2	–	16.0	–	dB
Input Return Loss	RL <sub>in</sub>	f = 0.8 to 1.0 GHz	IN-OUT1	10	15	–	dB
			IN-OUT2	15	20	–	dB
		f = 1.0 to 2.0 GHz	IN-OUT1/2	15	20	–	dB
		f = 2.0 to 2.5 GHz	IN-OUT1/2	–	20	–	dB
Output Return Loss	RL <sub>out</sub>	f = 0.8 to 1.0 GHz	IN-OUT1	10	15	–	dB
			IN-OUT2	15	20	–	dB
		f = 1.0 to 2.0 GHz	IN-OUT1/2	15	20	–	dB
		f = 2.0 to 2.5 GHz	IN-OUT1/2	–	20	–	dB
0.1 dB Loss Compression	P <sub>in (0.1 dB)</sub>	f = 1.0 GHz	IN-OUT1/2	35	37	–	dBm
Input Power		f = 2.0 GHz	IN-OUT1/2	35	37	–	dBm
2nd Harmonics	2f <sub>0</sub>	f = 1.0 GHz, P <sub>in</sub> = +35 dBm	IN-OUT1/2	65	75	–	dBc
		f = 2.0 GHz, P <sub>in</sub> = +33 dBm	IN-OUT1/2	65	70	–	dBc
3rd Harmonics	3f <sub>0</sub>	f = 1.0 GHz, P <sub>in</sub> = +35 dBm	IN-OUT1/2	65	75	–	dBc
		f = 2.0 GHz, P <sub>in</sub> = +33 dBm	IN-OUT1/2	65	75	–	dBc
Switching Speed	t <sub>sw</sub>			–	1	5	μs
Control Current	I <sub>cont</sub>	RF Non		–	5	50	μA
Supply Current	I <sub>DD</sub>	RF Non		–	40	200	μA

**EVALUATION CIRCUIT**

Off chip DC blocking capacitors value C1 = 56 pF, C2 = 1 000 pF (Bypass), using NEC standard evaluation board.

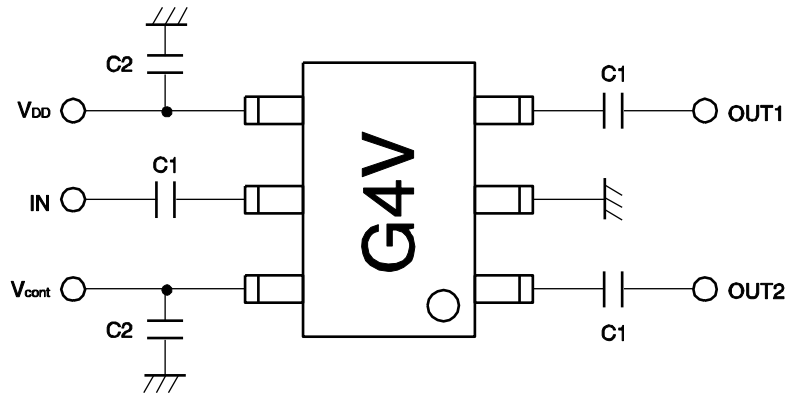

The application circuits and their parameters are for reference only and are not intended for use in actual design-ins.

**TRUTH TABLE**

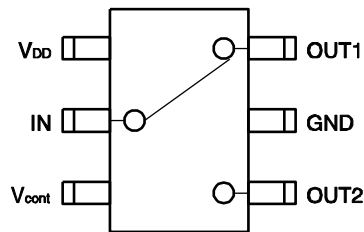

V <sub>cont</sub>	IN-OUT1	IN-OUT2
High	OFF	ON
Low	ON	OFF

PACKAGE DIMENSIONS

6-PIN SUPER MINIMOLD (UNIT: mm)

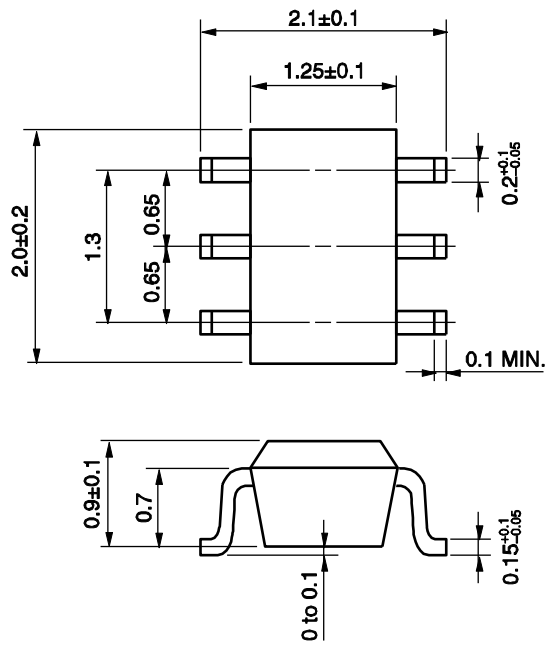

**RECOMMENDED SOLDERING CONDITIONS**

This product should be soldered and mounted under the following recommended conditions. For soldering methods and conditions other than those recommended below, contact your nearby sales office.

Soldering Method	Soldering Conditions	Condition Symbol
Infrared Reflow	Peak temperature (package surface temperature) : 260°C or below Time at peak temperature : 10 seconds or less Time at temperature of 220°C or higher : 60 seconds or less Preheating time at 120 to 180°C : 120±30 seconds Maximum number of reflow processes : 3 times Maximum chlorine content of rosin flux (% mass) : 0.2%(Wt.) or below	IR260
Wave Soldering	Peak temperature (molten solder temperature) : 260°C or below Time at peak temperature : 10 seconds or less Preheating temperature (package surface temperature) : 120°C or below Maximum number of flow processes : 1 time Maximum chlorine content of rosin flux (% mass) : 0.2%(Wt.) or below	WS260
Partial Heating	Peak temperature (terminal temperature) : 350°C or below Soldering time (per side of device) : 3 seconds or less Maximum chlorine content of rosin flux (% mass) : 0.2%(Wt.) or below	HS350

**Caution Do not use different soldering methods together (except for partial heating).**

<p><b>Caution</b></p>	<p>GaAs Products</p>	<p>This product uses gallium arsenide (GaAs). GaAs vapor and powder are hazardous to human health if inhaled or ingested, so please observe the following points.</p> <ul style="list-style-type: none"> <li>• Follow related laws and ordinances when disposing of the product. If there are no applicable laws and/or ordinances, dispose of the product as recommended below.             <ol style="list-style-type: none"> <li>1. Commission a disposal company able to (with a license to) collect, transport and dispose of materials that contain arsenic and other such industrial waste materials.</li> <li>2. Exclude the product from general industrial waste and household garbage, and ensure that the product is controlled (as industrial waste subject to special control) up until final disposal.</li> </ol> </li> <li>• Do not burn, destroy, cut, crush, or chemically dissolve the product.</li> <li>• Do not lick the product or in any way allow it to enter the mouth.</li> </ul>
-----------------------	----------------------	---

Компания «Life Electronics» занимается поставками электронных компонентов импортного и отечественного производства от производителей и со складов крупных дистрибьюторов Европы, Америки и Азии.

С конца 2013 года компания активно расширяет линейку поставок компонентов по направлению коаксиальный кабель, кварцевые генераторы и конденсаторы (керамические, пленочные, электролитические), за счёт заключения дистрибьюторских договоров

Мы предлагаем:

- Конкурентоспособные цены и скидки постоянным клиентам.
- Специальные условия для постоянных клиентов.
- Подбор аналогов.
- Поставку компонентов в любых объемах, удовлетворяющих вашим потребностям.
- Приемлемые сроки поставки, возможна ускоренная поставка.
- Доставку товара в любую точку России и стран СНГ.
- Комплексную поставку.
- Работу по проектам и поставку образцов.
- Формирование склада под заказчика.
- Сертификаты соответствия на поставляемую продукцию (по желанию клиента).
- Тестирование поставляемой продукции.
- Поставку компонентов, требующих военную и космическую приемку.
- Входной контроль качества.
- Наличие сертификата ISO.

В составе нашей компании организован Конструкторский отдел, призванный помогать разработчикам, и инженерам.

Конструкторский отдел помогает осуществить:

- Регистрацию проекта у производителя компонентов.
- Техническую поддержку проекта.
- Защиту от снятия компонента с производства.
- Оценку стоимости проекта по компонентам.
- Изготовление тестовой платы монтаж и пусконаладочные работы.



Тел: +7 (812) 336 43 04 (многоканальный)

Email: [org@lifeelectronics.ru](mailto:org@lifeelectronics.ru)