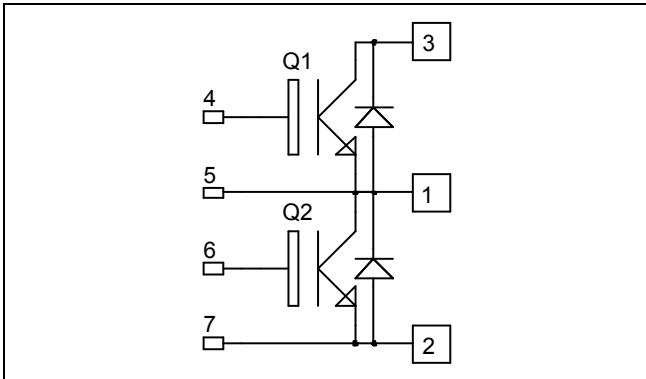

*Phase leg
Trench + Field Stop IGBT3
Power Module*

**$V_{CES} = 1700V$
 $I_C = 300A @ T_c = 80^\circ C$**

Application

- Welding converters
- Switched Mode Power Supplies
- Uninterruptible Power Supplies
- Motor control

Features

- Trench + Field Stop IGBT3 Technology
 - Low voltage drop
 - Low tail current
 - Switching frequency up to 20 kHz
 - Soft recovery parallel diodes
 - Low diode VF
 - Low leakage current
 - RBSOA and SCSOA rated
- Kelvin emitter for easy drive
- High level of integration
- M6 power connectors

Benefits

- Stable temperature behavior
- Very rugged
- Direct mounting to heatsink (isolated package)
- Low junction to case thermal resistance
- Easy paralleling due to positive T_C of V_{CEsat}
- RoHS Compliant

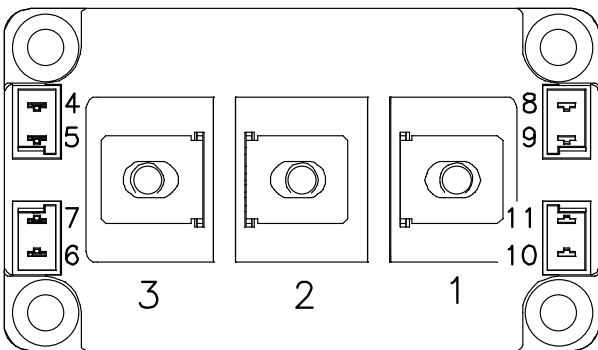
Absolute maximum ratings

Symbol	Parameter	Max ratings	Unit
V_{CES}	Collector - Emitter Breakdown Voltage	1700	V
I_C	Continuous Collector Current	$T_C = 25^\circ C$	400
		$T_C = 80^\circ C$	300
I_{CM}	Pulsed Collector Current	$T_C = 25^\circ C$	600
V_{GE}	Gate - Emitter Voltage	± 20	V
P_D	Maximum Power Dissipation	$T_C = 25^\circ C$	1470
RBSOA	Reverse Bias Safe Operating Area	$T_j = 125^\circ C$	600A@1650V

CAUTION: These Devices are sensitive to Electrostatic Discharge. Proper Handling Procedures Should Be Followed. See application note APT0502 on www.microsemi.com

All ratings @ $T_j = 25^\circ\text{C}$ unless otherwise specified

Electrical Characteristics

Symbol	Characteristic	Test Conditions	Min	Typ	Max	Unit
I_{CES}	Zero Gate Voltage Collector Current	$V_{GE} = 0V, V_{CE} = 1700V$			3	mA
$V_{CE(on)}$	Collector Emitter on Voltage	$V_{GE} = 15V$ $I_C = 300A$				
		$T_j = 25^\circ\text{C}$		2.0	2.5	V
		$T_j = 125^\circ\text{C}$		2.4		
$V_{GE(th)}$	Gate Threshold Voltage	$V_{GE} = V_{CE}, I_C = 12\text{ mA}$	5.2	5.8	6.4	V
I_{GES}	Gate – Emitter Leakage Current	$V_{GE} = 20V, V_{CE} = 0V$			400	nA

Dynamic Characteristics

Symbol	Characteristic	Test Conditions	Min	Typ	Max	Unit
C_{ies}	Input Capacitance	$V_{GE} = 0V, V_{CE} = 25V$		27		nF
C_{res}	Reverse Transfer Capacitance	$f = 1\text{MHz}$		0.9		
Q_G	Gate charge	$V_{GE} = \pm 15V, I_C = 300A$ $V_{CE} = 900V$		3.5		μC
$T_{d(on)}$	Turn-on Delay Time	Inductive Switching (25°C) $V_{GE} = \pm 15V$ $V_{Bus} = 900V$ $I_C = 300A$ $R_G = 4.7\Omega$		280		ns
T_r	Rise Time			80		
$T_{d(off)}$	Turn-off Delay Time			850		
T_f	Fall Time			120		
$T_{d(on)}$	Turn-on Delay Time	Inductive Switching (125°C) $V_{GE} = \pm 15V$ $V_{Bus} = 900V$ $I_C = 300A$ $R_G = 4.7\Omega$		300		ns
T_r	Rise Time			100		
$T_{d(off)}$	Turn-off Delay Time			1000		
T_f	Fall Time			200		
E_{on}	Turn On Energy	$V_{GE} = \pm 15V$ $V_{Bus} = 900V$				mJ
		$T_j = 25^\circ\text{C}$		71		
		$T_j = 125^\circ\text{C}$		105		
		$I_C = 300A$		64		
E_{off}	Turn Off Energy	$R_G = 4.7\Omega$				
		$T_j = 25^\circ\text{C}$		94		
I_{sc}	Short Circuit data	$V_{GE} \leq 15V ; V_{Bus} = 1000V$ $t_p \leq 10\mu\text{s} ; T_j = 125^\circ\text{C}$		1200		A

Reverse diode ratings and characteristics

Symbol	Characteristic	Test Conditions	Min	Typ	Max	Unit
V_{RRM}	Maximum Peak Repetitive Reverse Voltage		1700			V
I_{RRM}	Maximum Reverse Leakage Current	$V_R = 1700V$				μA
		$T_j = 25^\circ\text{C}$			750	
		$T_j = 125^\circ\text{C}$			1000	
I_F	DC Forward Current	$T_c = 80^\circ\text{C}$		300		A
V_F	Diode Forward Voltage	$I_F = 300A$				V
		$T_j = 25^\circ\text{C}$		1.8	2.2	
		$T_j = 125^\circ\text{C}$		1.9		
t_{rr}	Reverse Recovery Time	$I_F = 300A$ $V_R = 900V$ $di/dt = 3500A/\mu\text{s}$				ns
			$T_j = 25^\circ\text{C}$		385	
			$T_j = 125^\circ\text{C}$		490	
Q_{rr}	Reverse Recovery Charge		$T_j = 25^\circ\text{C}$		76	
		$T_j = 125^\circ\text{C}$		124		
E_{rr}	Reverse Recovery Energy	$T_j = 25^\circ\text{C}$		35		mJ
		$T_j = 125^\circ\text{C}$		70		

Thermal and package characteristics

Symbol	Characteristic	Min	Typ	Max	Unit	
R _{thJC}	Junction to Case Thermal Resistance	IGBT		0.085	°C/W	
		Diode		0.13		
V _{ISOL}	RMS Isolation Voltage, any terminal to case t=1 min, I _{isol} <1mA, 50/60Hz	4000			V	
T _J	Operating junction temperature range	-40		150	°C	
T _{STG}	Storage Temperature Range	-40		125		
T _C	Operating Case Temperature	-40		125		
Torque	Mounting torque	For terminals	M6	3	5	N.m
		To Heatsink	M6	3	5	
Wt	Package Weight			350	g	

D3 Package outline (dimensions in mm)

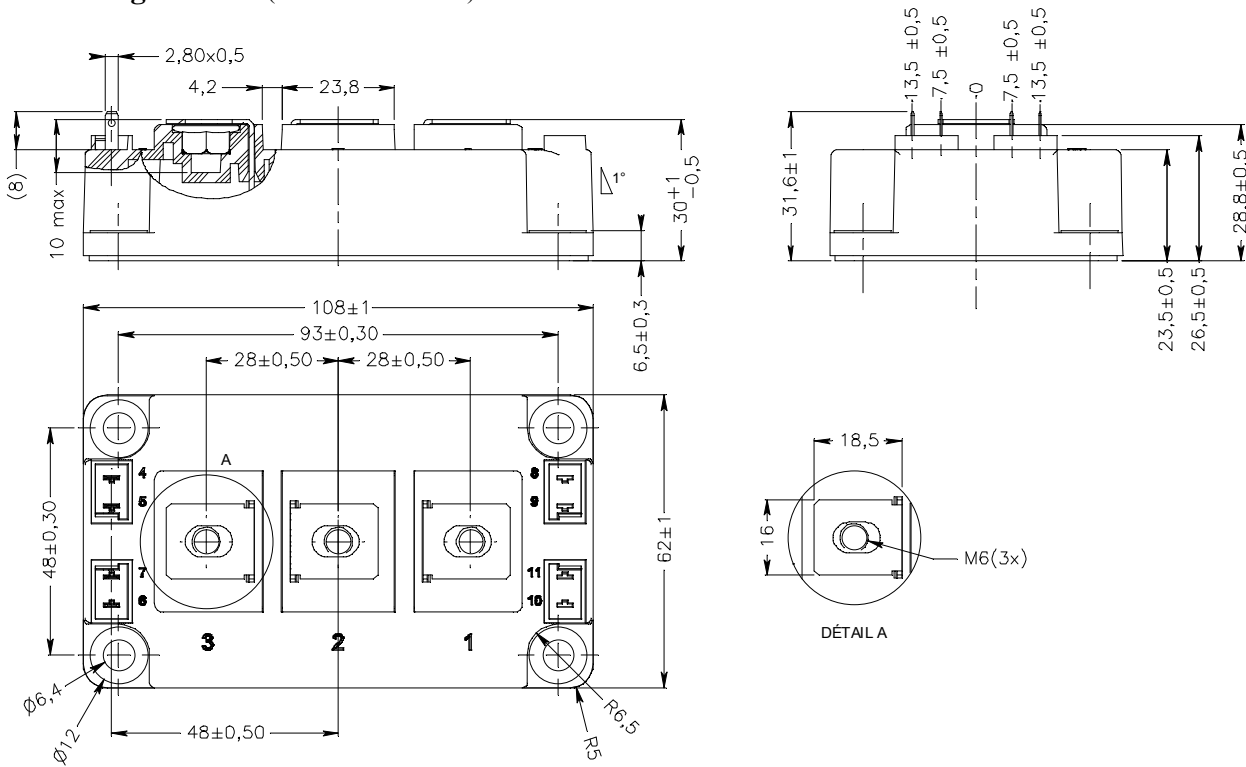

Typical Performance Curve

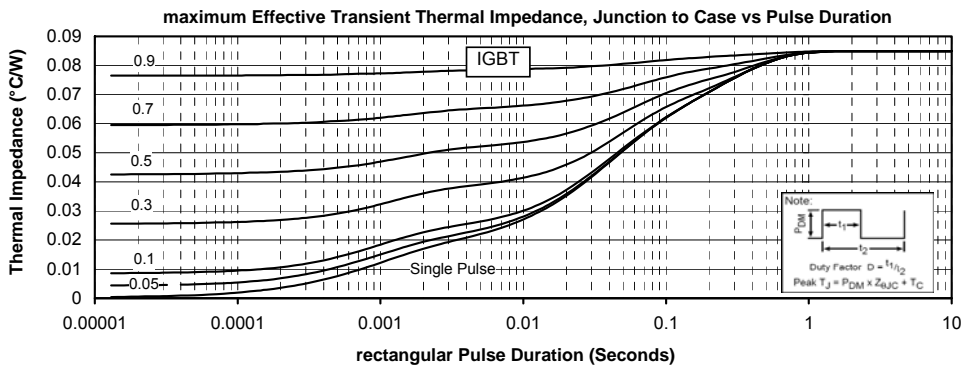
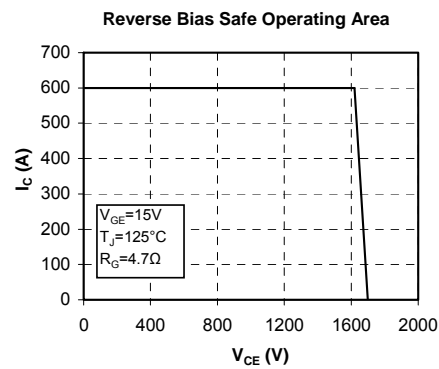
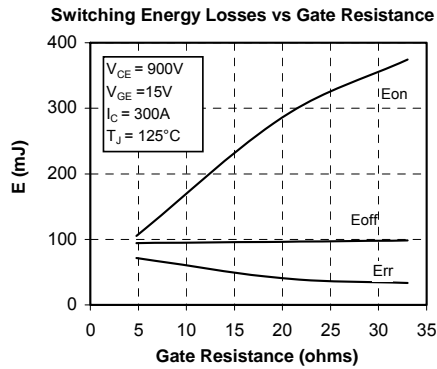
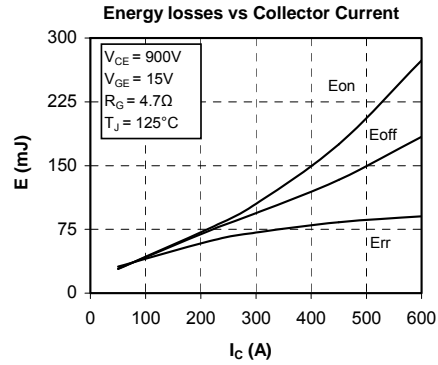
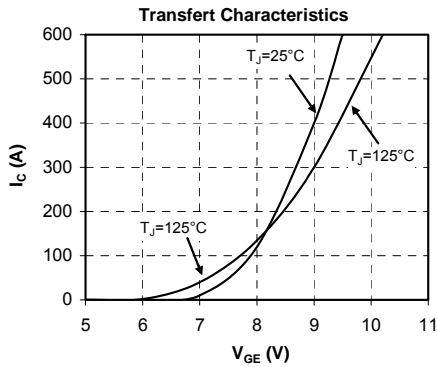
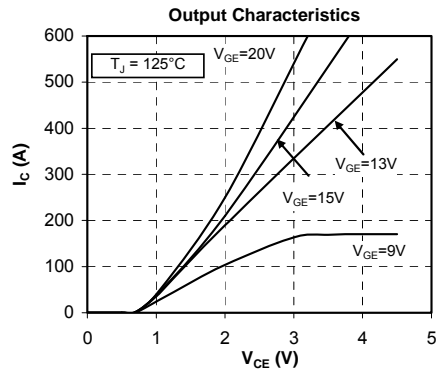
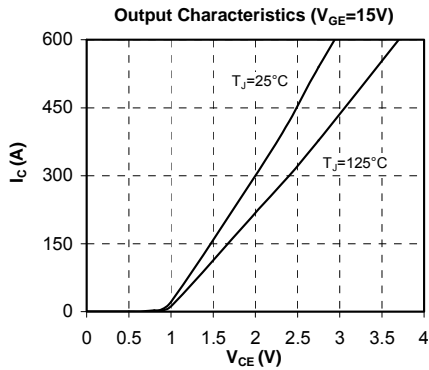

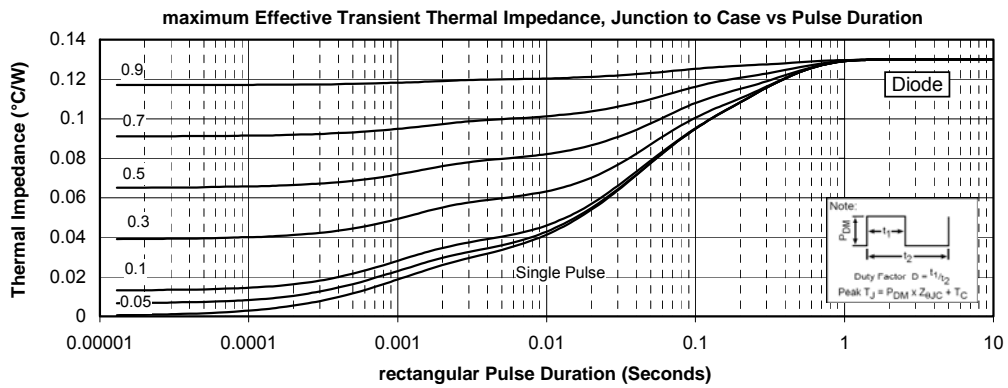
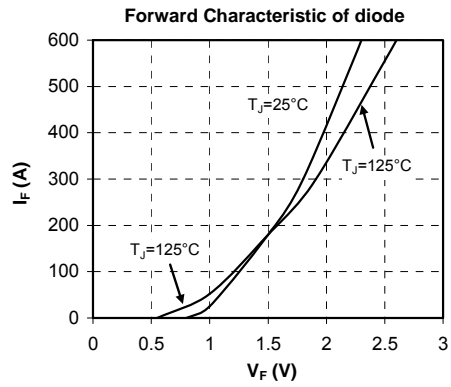
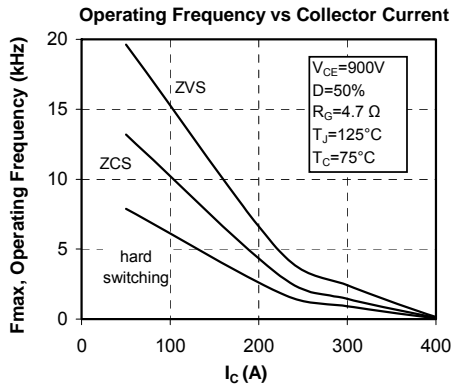

Microsemi reserves the right to change, without notice, the specifications and information contained herein

Компания «Life Electronics» занимается поставками электронных компонентов импортного и отечественного производства от производителей и со складов крупных дистрибьюторов Европы, Америки и Азии.

С конца 2013 года компания активно расширяет линейку поставок компонентов по направлению коаксиальный кабель, кварцевые генераторы и конденсаторы (керамические, пленочные, электролитические), за счёт заключения дистрибьюторских договоров

Мы предлагаем:

- Конкурентоспособные цены и скидки постоянным клиентам.
- Специальные условия для постоянных клиентов.
- Подбор аналогов.
- Поставку компонентов в любых объемах, удовлетворяющих вашим потребностям.
- Приемлемые сроки поставки, возможна ускоренная поставка.
- Доставку товара в любую точку России и стран СНГ.
- Комплексную поставку.
- Работу по проектам и поставку образцов.
- Формирование склада под заказчика.
- Сертификаты соответствия на поставляемую продукцию (по желанию клиента).
- Тестирование поставляемой продукции.
- Поставку компонентов, требующих военную и космическую приемку.
- Входной контроль качества.
- Наличие сертификата ISO.

В составе нашей компании организован Конструкторский отдел, призванный помогать разработчикам, и инженерам.

Конструкторский отдел помогает осуществить:

- Регистрацию проекта у производителя компонентов.
- Техническую поддержку проекта.
- Защиту от снятия компонента с производства.
- Оценку стоимости проекта по компонентам.
- Изготовление тестовой платы монтаж и пусконаладочные работы.



Тел: +7 (812) 336 43 04 (многоканальный)
Email: org@lifeelectronics.ru