

Power Optocoupler Terminal Block up to 10 A DEK-OV...

1. Brief Description

The Phoenix Contact Interface DEK terminals offer complete interface functions in terminal block housings with a width of only 6.2 mm (0.244 in.) These powerful interfaces do not only share the design of the terminal blocks but also their highly convenient application due to the use of standard terminal accessories.

The DEK family offers the suitable solution for every industrial voltage value for signal input as well as output.

High switching power is a standard feature of DEK-OV optocoupler terminals.

For applications with high switching frequency where electro-mechanical relays rapidly reach the end of their service life you can now apply the wear-resistant power optocoupler DEK-OV terminal block.

Integrated LEDs clearly signal the switching state of electronic terminal blocks and thus create a very good overview of the coupling level and the system.

Due to colored EB-DIK jumpering, terminals for supply and measuring signals the wiring is easy and efficient.

Integrated protection circuits such as free-wheeling diodes, diodes against polarity reversal and surge voltage elements protect coupling components and thus provide optimum system availability.

Powerful Optocoupler Terminals

Powerful interface modules are required to switch actuators and controlling devices such as contactors, solenoid valves or motors directly using cost-efficient digital output cards (low power, no galvanic isolation but high-pos.).

The Phoenix Contact DEK-OV interface terminals offer a complete output interface based on terminal blocks with a width of only 6.2 mm (0.244 in.).

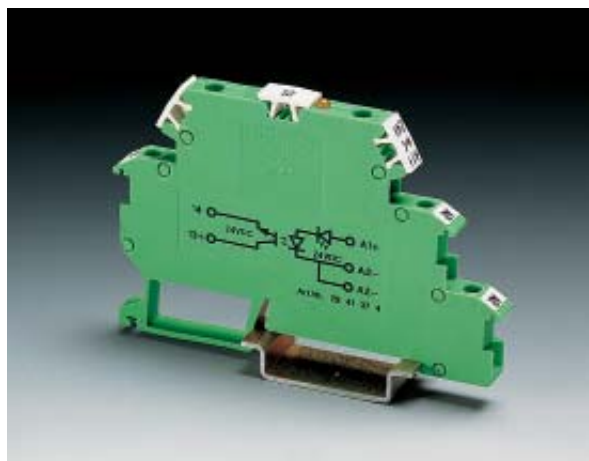

The key features of this power optocoupler include:

- Wear-resistant switching up to 24 V DC/10 A and 240 V AC/800 mA,
- Status display per LED,
- Galvanic isolation between input and output 2,5 kV,
- integrated protective circuit at the output,
- Zero voltage switch at AC output,
- Assembly and labeling is the same as for terminal blocks,
- Jumpering with the EB-DIK jumpers,
- Ambient temperature range – 20 °C (-40°F) up to + 60 °C (140°F),
- Also available as actuator type.

2. Technical Data

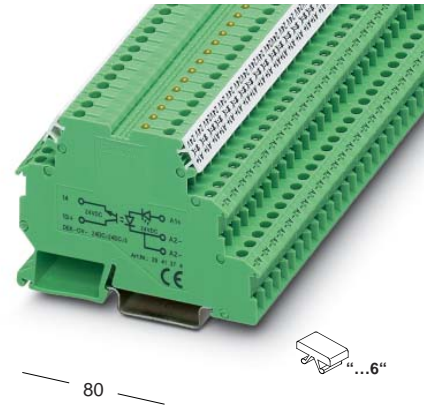
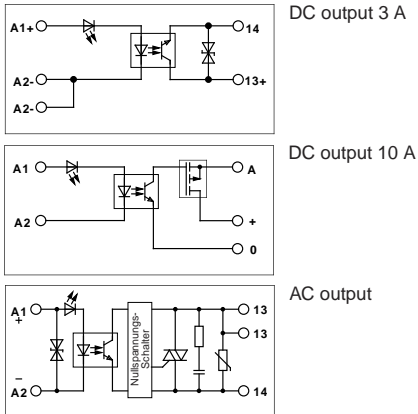

DEK-OV...

Output up to 10 A max.



Terminal width 6.2 mm (0.244 in.)

	solid [mm ²]	stranded	AWG
Connection data	0.2-2.5	0.2-2.5	24-14

Description	Input voltage
Power optocoupler terminal block, Input: Common mode voltage output: Common mode voltage	5 V DC 12 V DC 24 V DC
Power optocoupler terminal block, acutator principle, Input: Common mode voltage Output: Common mode voltage	24 V DC
Power optocoupler terminal block, Input: Common mode voltage output: AC voltage	5 V DC 12 V DC 24 V DC

Type	Order No.	Pcs. pkt.
DEK-OV- 5DC/24DC/3	29 41 36 1	10
DEK-OV-12DC/24DC/3	29 41 38 7	10
DEK-OV-24DC/24DC/3	29 41 37 4	10
DEK-OV- 5DC/24DC/10	29 61 75 2	10
DEK-OV-12DC/24DC/10	29 61 74 9	10
DEK-OV-24DC/24DC/10	29 64 32 2	10
DEK-OV-24DC/24DC/3/AKT	29 64 29 6	10
DEK-OV- 5DC/240AC/800	29 64 62 3	10
DEK-OV-12DC/240AC/800	29 64 63 6	10
DEK-OV-24DC/240AC/800	29 64 64 9	10
EB 2-DIK RD	I_{max} : 26 A	27 16 69 3
EB 3-DIK RD	26 A	27 16 74 5
EB 4-DIK RD	26 A	27 16 75 8
EB 5-DIK RD	26 A	27 16 76 1
EB 10-DIK RD	26 A	27 16 77 4
EB 2-DIK BU	26 A	27 16 64 8
EB 3-DIK BU	26 A	27 16 65 1
EB 4-DIK BU	26 A	27 16 66 4
EB 5-DIK BU	26 A	27 16 67 7
EB 10-DIK BU	26 A	27 16 68 0
EB 80-DIK BU	26 A	27 15 94 0
EB 80-DIK RD	26 A	27 15 95 3
EB 80-DIK WH	26 A	27 15 78 8

(1) Insertion jumper ¹⁾ , for average and lower level	Color:	Pos.
	Red	2-pos.
	Red	3-pos.
	Red	4-pos.
	Red	5-pos.
	Red	10-pos.
	blue	2-pos.
	blue	3-pos.
	blue	4-pos.
	blue	5-pos.
	blue	10-pos.
Can be disconnected	blue	80-pos.
	Red	80-pos.
	white	80-pos.

Power Optocoupler Terminal Blocks up to 10 A – DEK-OV

Technical Data

Input data (Input)

Operating voltage range [V DC] $\pm 20\%$
 Switching level 1-signal ("H")
 0-signal ("L")
 Current at nominal voltage [mA]
 Transmission frequency f_{limit} [Hz] (ohmic load)
 Input wiring

DC 3 A

5 12 24
 $0.8 \times U_N$
 $0.4 \times U_N$
 11 9 7

DC 10 A

5 12 24
 5 5 4
 100

AC

5 12 24
 10 11 11
 10

Operating indicator (LED yellow), protection against polarity reversal (10 A and AC type surge voltage protection)

Output data (Output)

Operating voltage range
 Periodical peak off-state voltage
 Maximum continuous load current
 Minimum load current
 Surge current
 Residual voltage at maximum load current
 Leakage in the off-state
 Max. phase shift (inductive load)
 I^2t value $I^2 \times t$ (t = 10 ms)
 Switching time t_{on}/t_{off}
 Output circuit

DC 3 A	DC 10 A	AC
3... 30 V DC	5... 30 V DC	10-253 V AC, 50/60 Hz
–	–	600 V
3 A (see 'Derating')	10 A (see 'Derating')	0.8 A (see 'Derating')
–	–	10 mA
–	–	30 A (t = 10 ms)
Approx. 0.2 V	< 50 mV	< 1 V
–	–	1.2 mA
–	–	$\cos\varphi = 0.5$
–	–	$4.5 A^2s$
Approx. 40 μs /200 μs	ca. 250 μs /800 μs	< 10 ms
2-wire - floating	2-wire - linked to the ground	2-wire - floating, zero voltage switch
Protection against polarity reversal, surge voltage protection RCV wiring		

Output wiring

General Data

Test voltage input/output
 Ambient operating temperature range
 Standards/specifications

2.5 kV AC, 50 Hz, 1 minute
 - 20 °C to +60°C (-4°F to +131°F)
 IEC 60 664/IEC 60 664 A/DIN VDE 0110,
 Pollution degree 2, surge voltage protection category III
 Any
 can be connected without distance
 Screw connection

Mounting position
 Mounting
 Connection type

¹⁾ Please observe the maximum current carrying capacity of the jumper and the number of connected inputs and outputs. The supply must only be provided directly at the insertion jumper.

²⁾ other voltage values on request.

Load current independent of the ambient temperature for DEK-OV-.../24DC/3 and DEK-OV-24DC/24DC/3/AKT,
 Nominal operating mode 100 % ED

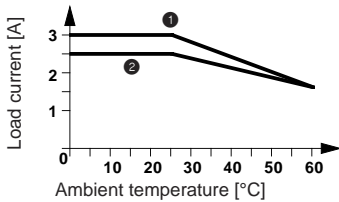

- ① Mounting, horizontal
- ② Mounting, vertical

Load current depending on the ambient temperature for DEK-OV-.../24DC/10
 Nominal operating mode 100 % ED

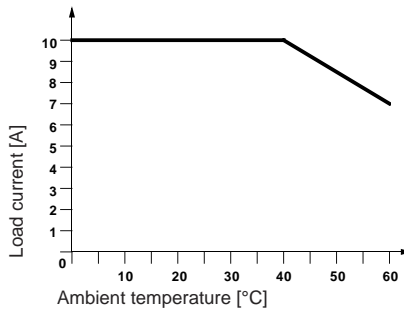

Load current independent of the ambient temperature for DEK-OV-.../240AC/800,
 Nominal operating mode 100 % ED

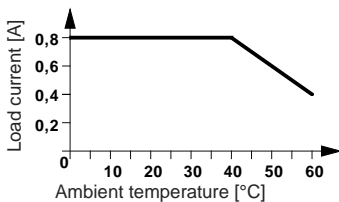

Note:

Types of insulating housings

Polyamid PA, not reinforced, see INTERFACE catalog
 Color: Green

Torque for terminal block screw see INTERFACE catalog.

Marking system and assembly material see CLIPLINE catalog.

The dimensioning cross section (see INTERFACE catalog) is meant for unstripped wires without ferrules.

Inductive loads must be limited to protect input and output with an effective protective circuit.

Items printed in bold can be supplied at short notice!

Компания «Life Electronics» занимается поставками электронных компонентов импортного и отечественного производства от производителей и со складов крупных дистрибьюторов Европы, Америки и Азии.

С конца 2013 года компания активно расширяет линейку поставок компонентов по направлению коаксиальный кабель, кварцевые генераторы и конденсаторы (керамические, пленочные, электролитические), за счёт заключения дистрибьюторских договоров

Мы предлагаем:

- Конкурентоспособные цены и скидки постоянным клиентам.
- Специальные условия для постоянных клиентов.
- Подбор аналогов.
- Поставку компонентов в любых объемах, удовлетворяющих вашим потребностям.
- Приемлемые сроки поставки, возможна ускоренная поставка.
- Доставку товара в любую точку России и стран СНГ.
- Комплексную поставку.
- Работу по проектам и поставку образцов.
- Формирование склада под заказчика.
- Сертификаты соответствия на поставляемую продукцию (по желанию клиента).
- Тестирование поставляемой продукции.
- Поставку компонентов, требующих военную и космическую приемку.
- Входной контроль качества.
- Наличие сертификата ISO.

В составе нашей компании организован Конструкторский отдел, призванный помогать разработчикам, и инженерам.

Конструкторский отдел помогает осуществить:

- Регистрацию проекта у производителя компонентов.
- Техническую поддержку проекта.
- Защиту от снятия компонента с производства.
- Оценку стоимости проекта по компонентам.
- Изготовление тестовой платы монтаж и пусконаладочные работы.



Тел: +7 (812) 336 43 04 (многоканальный)
Email: org@lifeelectronics.ru