

LT3922-1
36V 2A Boost LED Driver with
25,000:1 PWM Dimming

DESCRIPTION

Demonstration circuit DC2857A is a 36V 2A synchronous 2MHz boost LED driver featuring the [LT[®]3922-1](#). It drives a single string of LEDs at 330mA up to 34V when V_{IN} is between 7V and 28V. It runs down to $4V_{IN}$ with reduced I_{LED} and can withstand V_{IN} as high as 36V, but has over-voltage lockout (OVLO) set for 28V for this application. DC2857A runs at 2MHz switching frequency. Spread spectrum frequency modulation (SSFM) can be turned on with a simple jumper, reducing EMI. DC2857A comes with low EMI features including optimized layout, SSFM and input EMI filter. It passes CISPR 25 class 5 conducted and radiated EMI. It is protected against both open and short LED conditions and reports the faults.

The LT3922-1 has an input voltage range from 2.8V to 36V. Its internal synchronous 2A 40V switches allow up to 34V of LEDs on the output with room for over voltage protection and overshoot during an open LED event. It has adjustable switching frequency between 200kHz and 2.5MHz. It can be synchronized to an external source or programmed with SSFM for low EMI. The PWMTG high-side PWM MOSFET driver assists with short-circuit protection and versatility. LT3922-1 can be configured as a boost, boost-buck, or buck mode LED driver and maintain all of its low EMI, PWM dimming, and fault diagnostic features.

The LT3922-1 can be PWM dimmed with an external PWM signal or an internally-generated PWM signal. DC2857A has a jumper that can be set to switch between internally-generated PWM signal, externally-generated PWM signal, and no PWM signal (100% on). It can be analog dimmed with a control voltage on its control pin (CTRL).

When run with both PWM dimming and spread spectrum, the spread spectrum aligns itself with the PWM signal for flicker-free operation.

Small ceramic input and output capacitors are used to save space and cost. The board is designed with tiny, high frequency capacitors on both sides of the VOUT pins for a reduction in radiated EMI. The open LED overvoltage protection uses the IC's constant voltage regulation loop to regulate the output to approximately 37.5V if the LED string is opened, although it may reach almost 40V peak during transient from running LEDs to open. There is a protection diode from LED⁺ to GND to prevent negative ringing during a short-circuit. The output current can be monitored through the ISMON output pin.

Undervoltage and overvoltage lockout can be adjusted on the circuit with a few simple resistor choices.

There is an EMI filter on the input of DC2857A. Please follow the recommend layout and four-layer thickness of DC2857A for low EMI applications.

The LT3922-1 data sheet gives a complete description of the part, operation and applications information. The data sheet must be read in conjunction with this demo manual for demonstration circuit DC2857A. The LT3922EUFD-1 is assembled in a 28-lead plastic 4mm x 5mm QFN package with a thermally enhanced ground pad. Proper board layout is essential for maximum thermal performance. See the data sheet section Layout Considerations.

Design files for this circuit board are available at <http://www.analog.com/DC2857A>

All registered trademarks and trademarks are the property of their respective owners.

PERFORMANCE SUMMARY Specifications are at $T_A = 25^\circ\text{C}$

PARAMETER	CONDITIONS	MIN	TYP	MAX	UNITS
Input Voltage Low EMI V_{IN} Range	Operating $I_{LED} > 0\text{mA}$	4		28	V
Input Voltage Low EMI V_{IN} Range	Operating $V_{LED} = 34\text{V}$, $I_{LED} = 330\text{mA}$	7		28	V
Safe Input Voltage Low EMI V_{IN} Range		0		36	V
Switching Frequency	$R2 = 45.3\text{k}$, SSFM = OFF		2		MHz
Switching Frequency	$R2 = 45.3\text{k}$, SSFM = ON		2 to 2.5		MHz
I_{LED}	$R1 = 0.3\Omega$, $7.0\text{V} < \text{Low EMI}$, $V_{IN} < 28\text{V}$, $V_{LED} = 34\text{V}$		330		mA
V_{LED} range	$R4 = 1\text{M}$, $R5 = 33.2\text{k}$	V_{IN}		34	V
Open LED Voltage V_{OUT}	$R4 = 1\text{M}$, $R5 = 33.2\text{k}$, OPEN LOAD		37.5		V
Efficiency (100% PWM DC)	$PV_{IN} = 12\text{V}$, $V_{LED} = 34\text{V}$, $I_{LED} = 330\text{mA}$		90		%
Efficiency with EMI Filters Removed	$PV_{IN} = 12\text{V}$, $V_{LED} = 34\text{V}$, $I_{LED} = 330\text{mA}$		91		%
Internally-Generated PWM Dimming Range	Operating $JP1 = \text{INT}$, $JP2 = \text{INT}$	1/128		100%	
Internally-Generated PWM Dimming Frequency	Operating $JP1 = \text{INT}$, $JP2 = \text{INT}$, $R10 = 332\text{k}$		122		Hz

QUICK START PROCEDURE

Demonstration circuit DC2857A is easy to set up to evaluate the performance of the LT3922-1. Follow the procedure below:

- With power off, connect a string of LEDs that will run with forward voltage less than or equal to 34V (at 330mA) to the LED⁺ and LED⁻ terminals on the PCB as shown in Figure 1.
- Connect the EN/UVLO terminal to GND.
- Always-on LED operation. Set JP3 to NO SSFM to run without SSFM or external synchronization.
- With power off, connect the input power supply to the LOW EMI VIN and GND terminals. Make sure that the input voltage will not exceed 36V.
- Turn the input power supply on and make sure the voltage is between 5V and 36V to start operation.
- Release the EN/UVLO-to-GND connection.
- Observe the LED string running at the programmed LED current.
- To change the brightness with analog dimming, simply attach a voltage source the CTRL terminal and set the voltage between 0V and 1.5V. See data sheet for details.
- To change brightness with external PWM dimming, set JP1 to EXT and JP2 to EXT/ON. Attach a 3V rectangular waveform with varying duty cycle to the PWM terminal.
- To change brightness with internally-generated PWM dimming, set JP1 to INT and JP2 to INT. Adjust the setting of the VR1 variable resistor with a small flat-head screwdriver to toggle between 0% and 100% PWM dimming duty cycle in 1/128 steps.
- To enable spread spectrum frequency modulation, set JP3 to SSFM ON.

QUICK START PROCEDURE

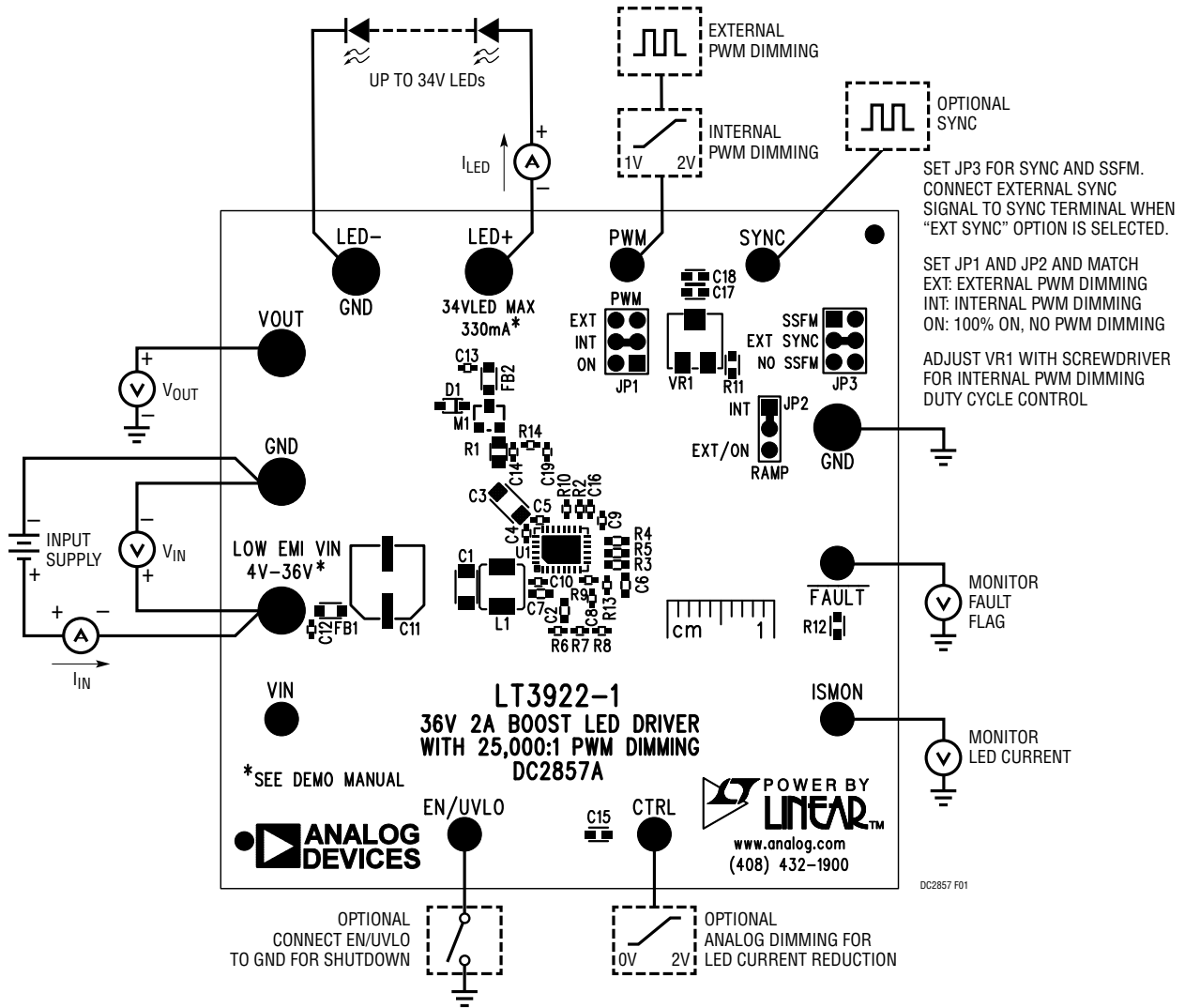

Figure 1. Test Procedure Setup Drawing for DC2857A

QUICK START PROCEDURE

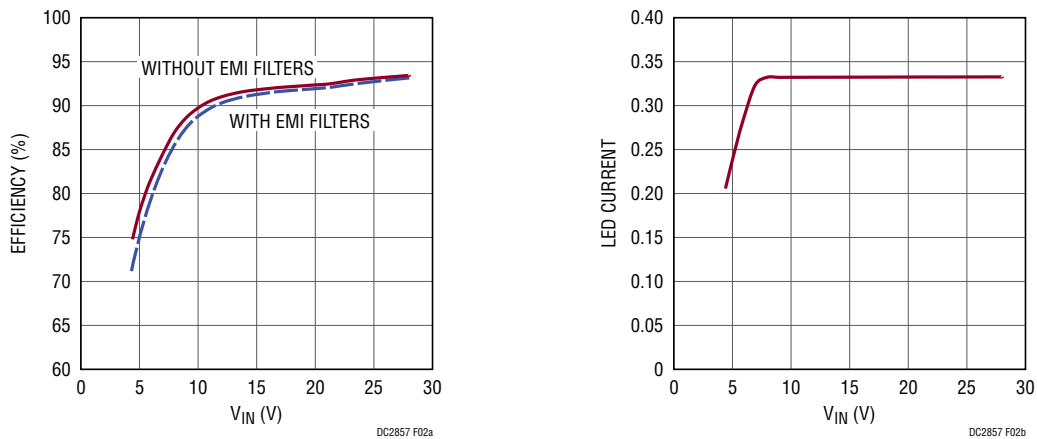

Figure 2. DC2857A Efficiency and LED Current Versus Input Voltage for 34V 330mA LED Load. Efficiency Remains High through the Range due to Synchronous Switching. At Low VIN, ILED Can Be Reduced due to Peak Switch Current Limit

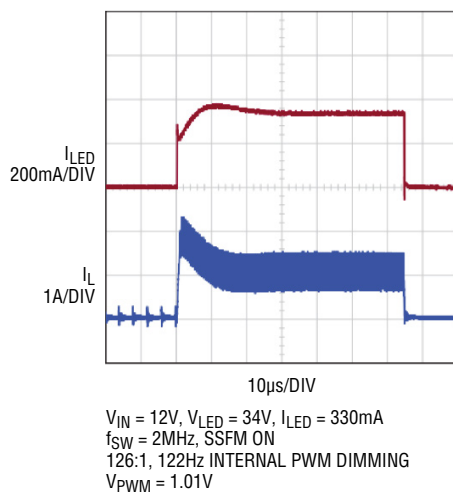

Figure 3. Infinite-Persist Scope Traces Show PWM Dimming and SSFM Working Together for Flicker-Free Brightness Control with Externally Generated PWM Dimming

QUICK START PROCEDURE

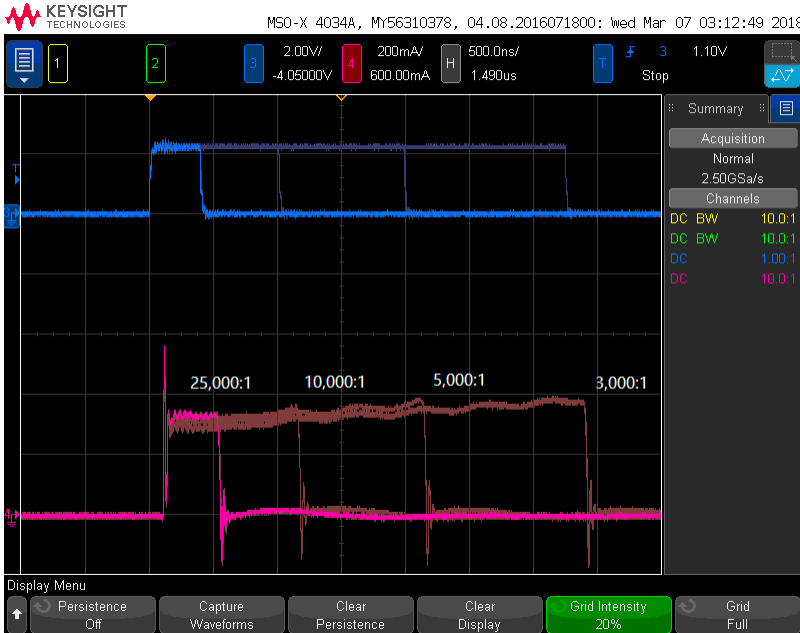

Figure 4. The LT3922-1 Has Dimming Ratios as High as 25,000:1 at 100Hz

DEMO MANUAL DC2857A

PARTS LIST

ITEM	QTY	REFERENCE	PART DESCRIPTION	MANUFACTURER/PART NUMBER
Required Circuit Components				
1	1	C1	CAP, X5R, 4.7 μ F, 50V, 10%, 1206	MURATA, GRM31CR71H475KA12L
2	1	C2	CAP, X5R, 1 μ F, 50V, 10%, 0603	TDK, C1608X5R1H105K080AB
3	1	C3	CAP, X5R, 10 μ F, 50V, 10%, 1206	AVX, 12065D106KAT2A
4	2	C4, C5	CAP, X5R, 0.47 μ F, 50V, 10%, 0402	TAIYO YUDEN, UMK105ABJ474KV-F
5	1	C6	CAP, X7R, 330pF, 50V, 10%, 0603	AVX, 06035C331KAT2A
6	1	C7	CAP, X7R, 2.2 μ F, 6.3V 10%, 0603	AVX, 06036C225KAT2A
7	1	C8	CAP, X5R, 1 μ F, 6.3V, 10%, 0402	MURATA, GRM155R60J105KE19D
8	2	C9, C10	CAP, X7R, 100nF, 6.3V, 10%, 0402	AVX, 04026C104KAT2A
21	1	L1	INDUCTOR, 4.7 μ H, 4.45mm x 4.06mm	WURTH ELEKTRONIK, 74437324047
22	1	M1	P-MOSFET, Si2319CDS, SOT23	VISHAY, SI2319CDS-T1-GE3
23	1	R1	RES, CHIP, 0.3, 1/3W, 1%, 0805	SUSUMU, RL1220S-R30-F
24	1	R2	RES, CHIP, 45.3k, 1/16W, 1%, 0402	VISHAY, CRCW040245K3FKED
25	1	R3	RES, CHIP, 27k, 1/10W, 1%, 0603	VISHAY, CRCW060327K0FKEA
26	1	R4	RES, CHIP, 1M, 1/10W, 1%, 0603	VISHAY, CRCW06031M00FKEA
27	1	R5	RES, CHIP, 33.2k, 1/10W, 1%, 0603	VISHAY, CRCW060333K2FKEA
28	1	R6	RES, CHIP, 499k, 1/16W, 1%, 0402	VISHAY, CRCW0402499KFKED
29	1	R7	RES, CHIP, 221k, 1/16W, 1%, 0402	VISHAY, CRCW0402221KFKED
30	1	R8	RES, CHIP, 31.6k, 1/16W, 1%, 0402	VISHAY, CRCW040231K6FKED
31	1	R9	RES, CHIP, 100k, 1/16W, 1%, 0402	VISHAY, CRCW0402100KFKED
32	1	R10	RES, CHIP, 332k, 1/16W, 1%, 0402	VISHAY, CRCW0402332KFKED
36	1	U1	I.C., LED DRIVER, 28QFN 4X5	ANALOG DEVICES, LT3922IUFD-1#PBF
Optional Demo Board Circuit Components				
9	1	C11	CAP, ALUM., 33 μ F, 50V, 20%, 6.3x7.7mm	SUN ELECTRONIC INDUSTRIES CORPORATION, 50CE33BS
10	2	C12, C13	CAP, X7R, 0.1 μ F, 50V, 10%, 0402	MURATA, GRM155R71H104KE14D
11	1	C14	CAP, X5R, 2.2 μ F, 6.3V, 10%, 0402	MURATA, GRM155R60J225ME15D
12	0	C15, C17, C18 (OPT)	CAP, OPTION, 0603	
13	0	C16, C19 (OPT)	CAP, OPTION, 0402	
14	1	D1	DIODE, SCHOTTKY, 40V, 1A, SOD323F	NXP, PMEG4010CEJ, 115
17	1	FB1	CHIP, BEAD, 600 Ω , 0805	WURTH ELEKTRONIK, 742792040
18	1	FB2	CHIP, BEAD, 1.5k Ω , 0805	WURTH ELEKTRONIK, 742792097
33	1	R11	RES, CHIP, 91k, 1/10W, 5%, 0603	VISHAY, CRCW060391K0JNEA
34	1	R12	RES, CHIP, 51k, 1/10W, 1%, 0603	VISHAY, CRCW060351K0FKEA
35	0	R13, R14 (OPT)	RES, OPTION, 0402	
37	1	VR1	TRIMMER., 100k Ω , 0.25W, SMD	BOURNS, 3314J-1-104E
Hardware: For Demo Board Only				
15	6	E1, E3, E8, E11-E13	TEST POINT, TURRET, .094"MTG. HOLE	MILL-MAX, 2501-2-00-80-00-00-07-0
16	7	E2, E4-E7, E9, E10	TEST POINT, TURRET, .061"MTG. HOLE	MILL-MAX, 2308-2-00-80-00-00-07-0
19	2	JP1, JP3	HEADER 3 PIN 0.079 DOUBLE ROW	WURTH ELEKTRONIK, 62000621121
20	1	JP2	HEADER 3 PIN 0.079 SINGLE ROW	WURTH ELEKTRONIK, 62000311121
38	3	XJP1, XJP2, XJP3	SHUNT, 0.079" CENTER	WURTH ELEKTRONIK, 60800213421

SCHEMATIC DIAGRAM

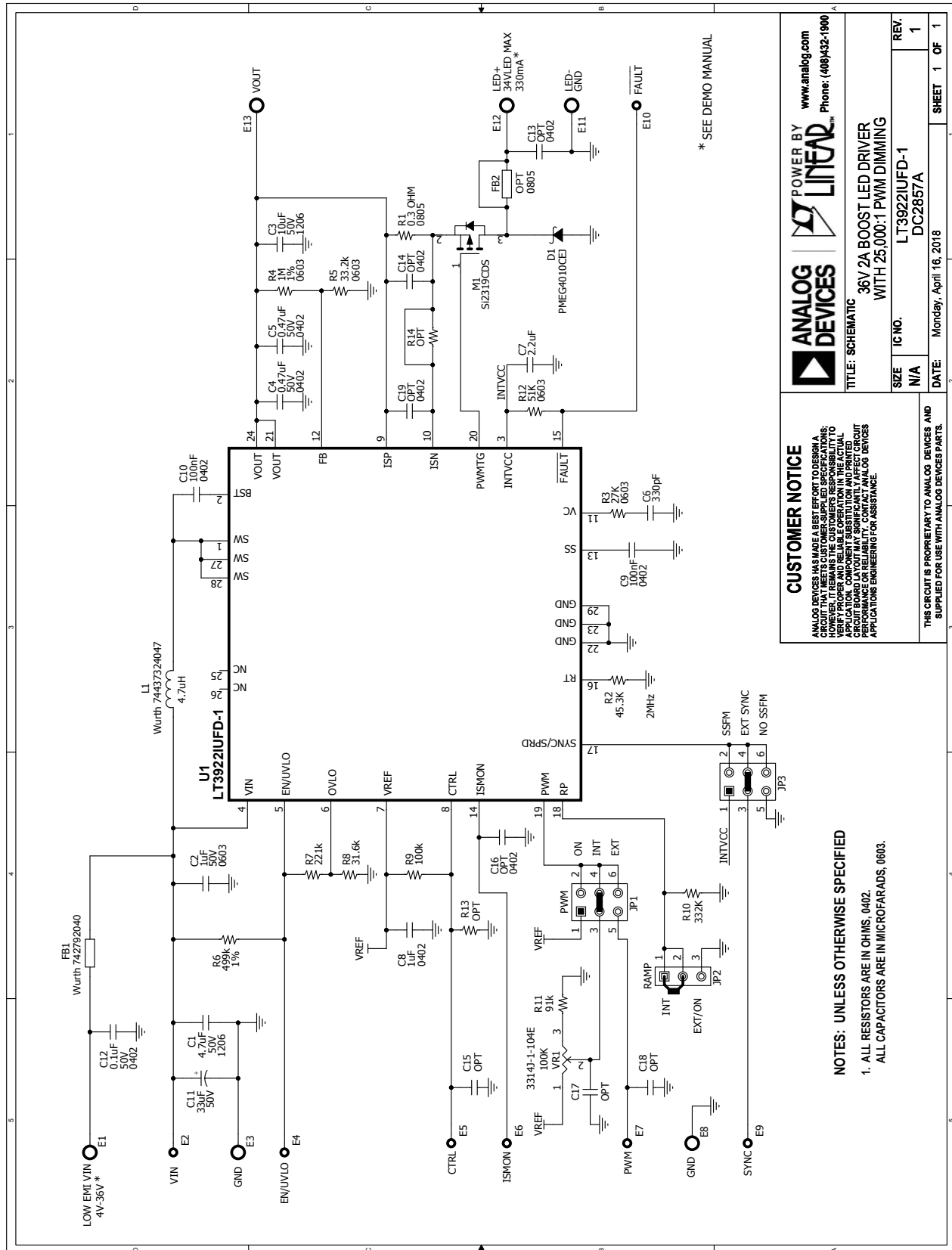

* SEE DEMO MANUAL

POWER BY
LINEAR

www.analog.com
Phone: (408)432-1900

TITLE: SCHEMATIC **36V 2A BOOST LED DRIVER WITH 25,000:1 PWM DIMMING**

SIZE	N/A	IC NO.	LT3922IUFD-1	REV.	1
DATE:	Monday, April 16, 2018			SHEET	1 OF 1

CUSTOMER NOTICE

ANALOG DEVICES HAS MADE A BEST EFFORT TO DESIGN A CIRCUIT THAT MEETS THE CUSTOMER SPECIFICATIONS. CUSTOMERS SHOULD VERIFY THE ACTUAL PERFORMANCE OF THE COMPONENTS IN THEIR APPLICATION. COMPONENT SUBSTITUTION AND PRINTED CIRCUIT BOARD MANUFACTURING VARIATIONS CAN AFFECT PERFORMANCE OR RELIABILITY. CONTACT ANALOG DEVICES APPLICATIONS ENGINEERING FOR ASSISTANCE.

THIS CIRCUIT IS PROPRIETARY TO ANALOG DEVICES AND SUPPLIED FOR USE WITH ANALOG DEVICES PARTS.

NOTES: UNLESS OTHERWISE SPECIFIED

1. ALL RESISTORS ARE IN OHMS, 0402.
2. ALL CAPACITORS ARE IN MICROFARADS, 0603.



ESD Caution

ESD (electrostatic discharge) sensitive device. Charged devices and circuit boards can discharge without detection. Although this product features patented or proprietary protection circuitry, damage may occur on devices subjected to high energy ESD. Therefore, proper ESD precautions should be taken to avoid performance degradation or loss of functionality.

Legal Terms and Conditions

By using the evaluation board discussed herein (together with any tools, components documentation or support materials, the "Evaluation Board"), you are agreeing to be bound by the terms and conditions set forth below ("Agreement") unless you have purchased the Evaluation Board, in which case the Analog Devices Standard Terms and Conditions of Sale shall govern. Do not use the Evaluation Board until you have read and agreed to the Agreement. Your use of the Evaluation Board shall signify your acceptance of the Agreement. This Agreement is made by and between you ("Customer") and Analog Devices, Inc. ("ADI"), with its principal place of business at One Technology Way, Norwood, MA 02062, USA. Subject to the terms and conditions of the Agreement, ADI hereby grants to Customer a free, limited, personal, temporary, non-exclusive, non-sublicensable, non-transferable license to use the Evaluation Board FOR EVALUATION PURPOSES ONLY. Customer understands and agrees that the Evaluation Board is provided for the sole and exclusive purpose referenced above, and agrees not to use the Evaluation Board for any other purpose. Furthermore, the license granted is expressly made subject to the following additional limitations: Customer shall not (i) rent, lease, display, sell, transfer, assign, sublicense, or distribute the Evaluation Board; and (ii) permit any Third Party to access the Evaluation Board. As used herein, the term "Third Party" includes any entity other than ADI, Customer, their employees, affiliates and in-house consultants. The Evaluation Board is NOT sold to Customer; all rights not expressly granted herein, including ownership of the Evaluation Board, are reserved by ADI. CONFIDENTIALITY. This Agreement and the Evaluation Board shall all be considered the confidential and proprietary information of ADI. Customer may not disclose or transfer any portion of the Evaluation Board to any other party for any reason. Upon discontinuation of use of the Evaluation Board or termination of this Agreement, Customer agrees to promptly return the Evaluation Board to ADI. ADDITIONAL RESTRICTIONS. Customer may not disassemble, decompile or reverse engineer chips on the Evaluation Board. Customer shall inform ADI of any occurred damages or any modifications or alterations it makes to the Evaluation Board, including but not limited to soldering or any other activity that affects the material content of the Evaluation Board. Modifications to the Evaluation Board must comply with applicable law, including but not limited to the RoHS Directive. TERMINATION. ADI may terminate this Agreement at any time upon giving written notice to Customer. Customer agrees to return to ADI the Evaluation Board at that time. LIMITATION OF LIABILITY. THE EVALUATION BOARD PROVIDED HEREUNDER IS PROVIDED "AS IS" AND ADI MAKES NO WARRANTIES OR REPRESENTATIONS OF ANY KIND WITH RESPECT TO IT. ADI SPECIFICALLY DISCLAIMS ANY REPRESENTATIONS, ENDORSEMENTS, GUARANTEES, OR WARRANTIES, EXPRESS OR IMPLIED, RELATED TO THE EVALUATION BOARD INCLUDING, BUT NOT LIMITED TO, THE IMPLIED WARRANTY OF MERCHANTABILITY, TITLE, FITNESS FOR A PARTICULAR PURPOSE OR NON-INFRINGEMENT OF INTELLECTUAL PROPERTY RIGHTS. IN NO EVENT WILL ADI AND ITS LICENSORS BE LIABLE FOR ANY INCIDENTAL, SPECIAL, INDIRECT, OR CONSEQUENTIAL DAMAGES RESULTING FROM CUSTOMER'S POSSESSION OR USE OF THE EVALUATION BOARD, INCLUDING BUT NOT LIMITED TO LOST PROFITS, DELAY COSTS, LABOR COSTS OR LOSS OF GOODWILL. ADI'S TOTAL LIABILITY FROM ANY AND ALL CAUSES SHALL BE LIMITED TO THE AMOUNT OF ONE HUNDRED US DOLLARS (\$100.00). EXPORT. Customer agrees that it will not directly or indirectly export the Evaluation Board to another country, and that it will comply with all applicable United States federal laws and regulations relating to exports. GOVERNING LAW. This Agreement shall be governed by and construed in accordance with the substantive laws of the Commonwealth of Massachusetts (excluding conflict of law rules). Any legal action regarding this Agreement will be heard in the state or federal courts having jurisdiction in Suffolk County, Massachusetts, and Customer hereby submits to the personal jurisdiction and venue of such courts. The United Nations Convention on Contracts for the International Sale of Goods shall not apply to this Agreement and is expressly disclaimed.

Компания «Life Electronics» занимается поставками электронных компонентов импортного и отечественного производства от производителей и со складов крупных дистрибьюторов Европы, Америки и Азии.

С конца 2013 года компания активно расширяет линейку поставок компонентов по направлению коаксиальный кабель, кварцевые генераторы и конденсаторы (керамические, пленочные, электролитические), за счёт заключения дистрибьюторских договоров

Мы предлагаем:

- Конкуренспособные цены и скидки постоянным клиентам.
- Специальные условия для постоянных клиентов.
- Подбор аналогов.
- Поставку компонентов в любых объемах, удовлетворяющих вашим потребностям.
- Приемлемые сроки поставки, возможна ускоренная поставка.
- Доставку товара в любую точку России и стран СНГ.
- Комплексную поставку.
- Работу по проектам и поставку образцов.
- Формирование склада под заказчика.
- Сертификаты соответствия на поставляемую продукцию (по желанию клиента).
- Тестирование поставляемой продукции.
- Поставку компонентов, требующих военную и космическую приемку.
- Входной контроль качества.
- Наличие сертификата ISO.

В составе нашей компании организован Конструкторский отдел, призванный помогать разработчикам, и инженерам.

Конструкторский отдел помогает осуществить:

- Регистрацию проекта у производителя компонентов.
- Техническую поддержку проекта.
- Защиту от снятия компонента с производства.
- Оценку стоимости проекта по компонентам.
- Изготовление тестовой платы монтаж и пусконаладочные работы.



Тел: +7 (812) 336 43 04 (многоканальный)
Email: org@lifeelectronics.ru