

Rectangular, Multiple-Position Rack/Panel Insulation Displacement Connectors (IDC)

QR/P18 Series



Overview

The QR/P18 Series of miniature rack/panel connectors is designed for the complete segmentation of the structure of the external holder/terminal units of the well-received QR/P Series of plug-in rectangular rack/panel connectors; furthermore, the subsequent insertion of the harnessed terminal unit affords a more efficient harness mounting task. These connectors are configured with 12, 18, or 24 (insulation displacement connection) positions in the signal portion, and 4 (crimp) positions in the power supply portion.

Features

1. Completely segmented structure of the external holder/terminal unit

In order to improve the harness mounting task, the connectors are designed for the complete segmentation of the external holder and the signal/power supply unit, and the method of subsequently inserting harnessed products aims to improve the workability of the power supply/signal section harness as well as the mounting of the set.

2. Signal unit

The signal unit uses the highly reliable insulation displacement connection method. (The wire is AWG #26 and the insulation outside diameter is 0.88 mm.)

The insulation displacement task can now be used by fitting a special applicator to a commercially available automatic insulation displacement machine, or a manual press can also be selected.

3. Power supply portion

The power supply terminals permit the use of a crimp harness using wire of AWG #16 to 18 (and insulation outside diameter of 2.1 to 2.2 mm), and can accommodate a maximum of 12 A.

4. Sequenced structure

Connectors possess two sequenced contacts in the signal male unit and one sequenced contact in the power supply female unit making them perfect in terms of safety too.

5. Panel installation

Installation to a panel uses a single-action method on the anchored side and a floating screw structure on the floating side which permits smooth insertion and disconnection without forcing.

6. RoHS compliant

All components and materials comply with the requirements of the EU Directive 2002/95/EC.

*A portion of this series is suitably constructed for high-speed differential transfer, and using a suitable cable, transfer of 2.5Gbps per pair is possible.



2.5 Gbps Eye Pattern Waveform

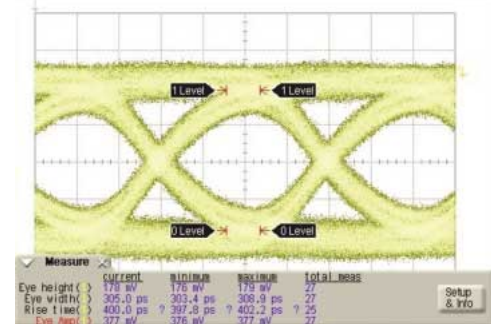

2.5Gbps Scale
 AWG28 2m X : 100ps/div
 Y : 100V/div

Applications

PPC, transmitting and receiving devices, data communications equipment, vending machines, measuring instruments, factory automation equipment, and other high-speed transfer applications, etc.

■Product Specifications

Ratings	Voltage rating	125 V AC (Signal contacts) 300V AC (Power contacts)	Operating temperature range	-40°C to +105°C (Note 1)
	Current rating	1A (Signal contacts) 12A (Power contacts)		

Item	Specification	Conditions
1. Contact resistance	50mΩ max. (Signal contacts) (Note 2) 10mΩ max. (Power contacts) (Note 2)	100 mA
2. Insulation resistance	1000MΩ min. (Signal contacts) 5000MΩ min. (Power contacts)	500 V DC
3. Withstanding Voltage	No flashover or insulation breakdown.	500 V AC / one minute
4. Durability (mating / un-mating)	Contact resistance: 70mΩ max. (Signal contacts) 20mΩ max. (Power contacts)	3000 cycles
5. Vibration	No electrical discontinuity of 10μs or more.	Frequency: 10 to 55 Hz, single amplitude of 0.75 mm, 2 hours in each of the 3 axis.
6. Shock	No damage, cracks, or parts dislocation.	Acceleration of 490 m/s ² , 11 ms duration, sine half-wave waveform, 3 cycles in each of the 3 axis
7. Temperature cycle	Contact resistance: 70mΩ max. (Signal contacts) 20mΩ max. (Power contacts) No damage, cracks, or parts dislocation.	Temperature: -55°C→+5°C to +35°C→+105°C→+5°C to +35°C Time: 30→5→30→5 (Minutes) 5 cycles
8. Humidity (Steady state)	Insulation resistance: 100MΩ min. (Signal contacts, state) 3000MΩ min. (Power contacts, state) No damage, cracks, or parts dislocation.	96 hours at 40°C and RH 90% to 95%
9. Salt mist	No corrosions.	5% salt water solution for 48 hours

Note1: Includes temperature rise caused by current flow.

Note2: Excludes wire conductor resistance.

■Materials

Products	Components	Material	Finish	Remarks
External holder	Insulator	PBT	————	UL94V-0
	Insulator	PA	————	UL94V-0
Signal contact unit	Female contacts	Phosphor bronze	Gold plated	————
	Male contacts	Phosphor bronze	Gold plated	————
Power contact unit	Insulator	PBT	————	UL94V-0
	Female contacts	Phosphor bronze	Gold plated	————
	Male contacts	Phosphor bronze	Gold plated	————
Power supply contacts	Female contacts	Copper alloy	Gold plated + Tin copper plated	————
	Male contacts	Copper alloy	Gold plated + Tin copper plated	————

■Function Diagram

●Power supply/signal combination type

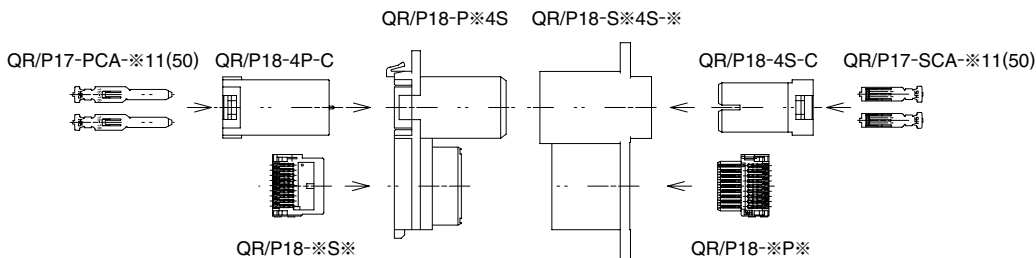

●Signal type

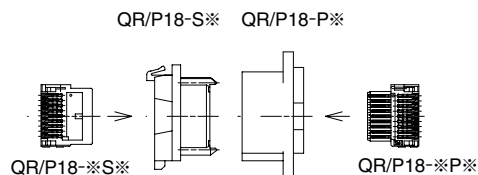

■ Ordering information

● External holder.

QR / P18 - S A 4 P - A

①
②
③
④
⑤
⑥

① Series name	④ Number of power contact
② Signal contact type S: Female contact P: Male contact	⑤ Power contact type S: Female contact P: Male contact
③ Number of signal contact of external holder A: 12 pos. (Contact pitch 1.5mm) B: 18 pos. (Contact pitch 1.5mm) C: 24 pos. (Contact pitch 1.5mm)	⑥ Applicable panel thickness A: 2mm B: 1.5mm

● Signal contact termination block

QR / P18 - 12 S A

①
②
③
④

① Series name	④ Number of signal contact of signal contact termination block A: 12 pos. (Contact pitch 1.5mm) B: 18 pos. (Contact pitch 1.5mm) C: 24 pos. (Contact pitch 1.5mm)
② Number of signal contact	
③ Signal contact type S: Female contact P: Male contact	

● Power contact insert

QR / P18 - 4 P - C

①
②
③
④

① Series name	④ Connector type C: Crimp housing
② Number of power contact	
③ Power contact type S: Female contact P: Male contact	

● Power contact

QR / P17 - PC A - 1 1 1

①
②
③
④
⑤
⑥

① Series name	④ Packaging 1: Pack packaging 2: Reel packaging
② Power contact type PC: Male crimp contact SC: Female crimp contact	⑤ Applicable wire 1: AWG#16 to 18
③ Applicable wire style A: UL1015	⑥ Contact plating 1: Gold plated

External holder



Mated condition (Shown for reference)



Note: Establish panel mounting so that the mating gap dimensions of the power supply side and the signal side are 1.5 mm or less.

Female power contact, male signal contact type



Panel cutout

Applicable panel thickness: 2.0mm

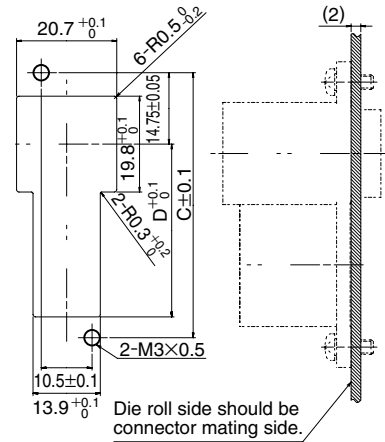

Part number	CL No.	Number of contacts		A	B	C	D	RoHS
		Signal	Power					
QR/P18-PA4S	CL221-0293-8	12	4	54.65	46.25	46.25	27.2	YES
QR/P18-PB4S	CL221-0313-3	18	4	58.65	50.25	50.25	31.2	
QR/P18-PC4S	CL221-0297-9	24	4	63.15	54.75	54.75	35.7	

Panel attachment screw (QR/P15-SCREW CL221-0251-8) is optional.



●Male power contact, female signal contact type



Panel cutout

Applicable panel thickness: 2.0mm

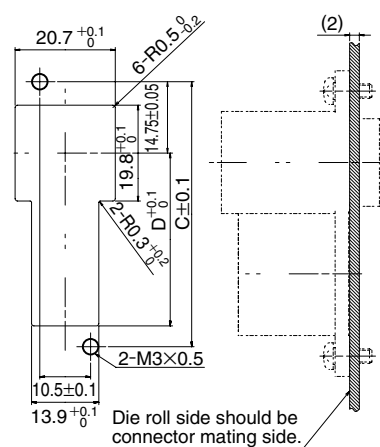

Part number	CL No.	Number of contacts		A	B	C	D	RoHS
		Signal	Power					
QR/P18-SA4P-A	CL221-0294-0	12	4	43.85	37.9	27.25	17.3	YES
QR/P18-SB4P-A	CL221-0315-9	18	4	47.85	41.9	31.25	21.3	
QR/P18-SC4P-A	CL221-0298-1	24	4	52.35	46.4	35.75	25.8	

External holder (Signal type)



Mated condition (Shown for reference)

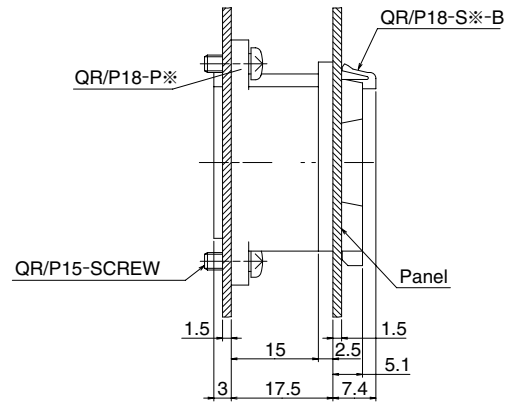

Note: Establish panel mounting so that the mating gap dimensions of the power supply side and the signal side are 1.5 mm or less.

Male signal contact type

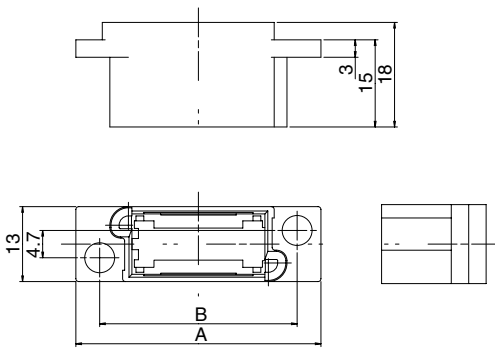

Panel cutout

Applicable panel thickness: 1.5mm

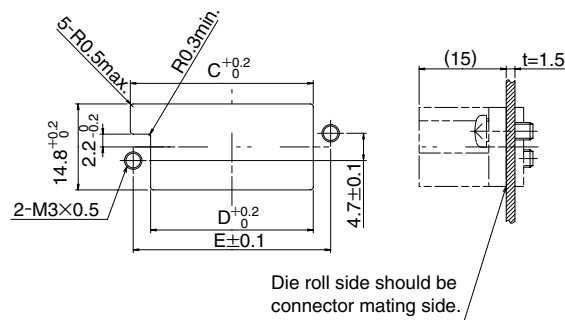

Part number	CL No.	Number of contacts	A	B	C	D	E	RoHS
		Signal						
QR/P18-PB	CL221-0309-6	18	37.7	29.5	27.0	23.5	29.5	YES
QR/P18-PC	CL221-0311-8	24	42.2	34.0	31.5	28.0	34.0	

Panel attachment screw (QR/P15-SCREW CL221-0251-8) is optional.

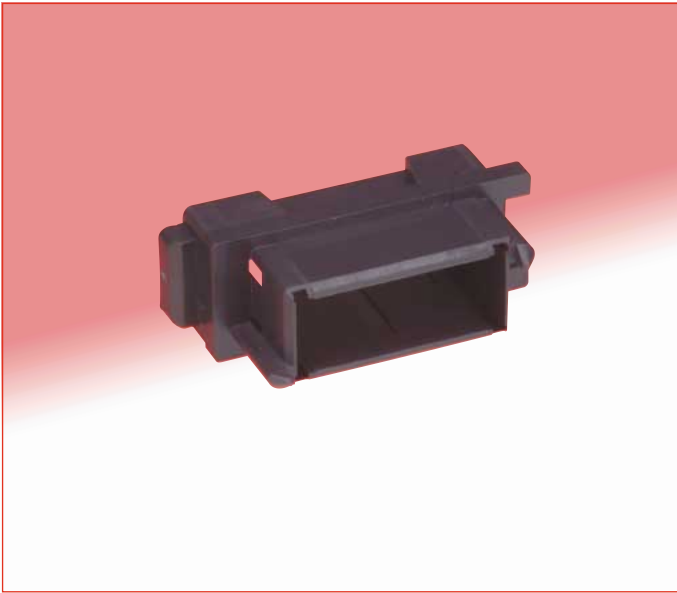

●Female signal contact type

Panel cutout Applicable panel thickness: 1.5mm

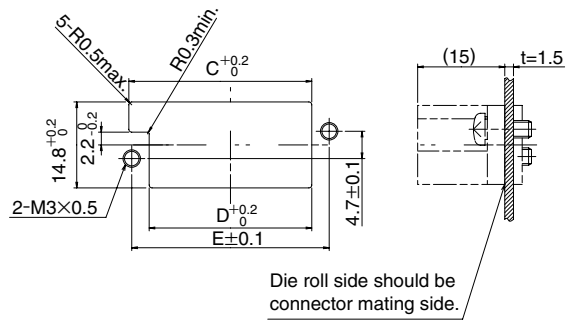
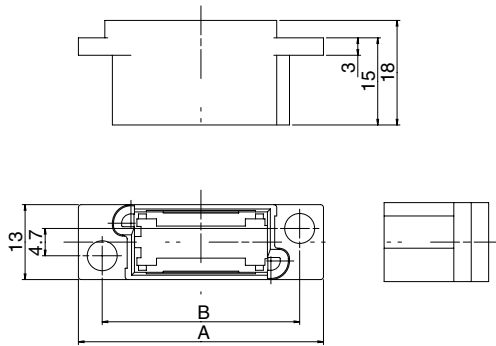

Part number	CL No.	Number of contacts	A	B	C	D	RoHS
		Signal					
QR/P18-SB-B	CL221-0310-5	18	28.05	25.1	13	7.3	YES
QR/P18-SC-B	CL221-0312-0	24	32.55	29.6	15.25	11.8	

■Signal contact termination block

●Male, contact pitch 1.5mm

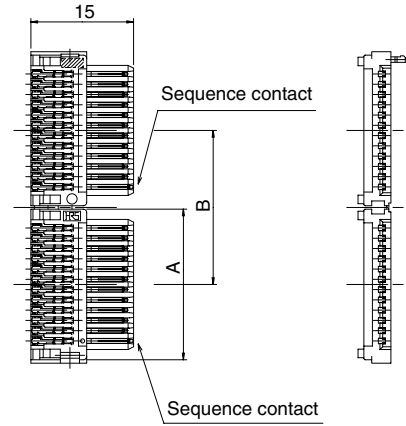

Part number	CL No.	Number of contacts	A	B	RoHS
QR/P18-12PA	CL221-0291-2	12	13.5	14	YES
QR/P18-18PB	CL221-0285-0	18	17.5	18	
QR/P18-24PC	CL221-0295-3	24	22	22.5	

Adscable cable: AWG#26, insulator diameter 0.88mm

●Female, contact pitch 1.5mm

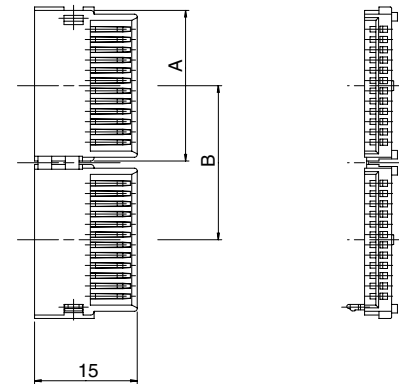

Part number	CL No.	Number of contacts	A	B	RoHS
QR/P18-12SA	CL221-0292-5	12	13.5	14	YES
QR/P18-18SB	CL221-0286-2	18	17.5	18	
QR/P18-24SC	CL221-0296-6	24	22	22.5	

Applicable cable: AWG#26, insulator diameter 0.88mm

■ Power contact insert

● Male

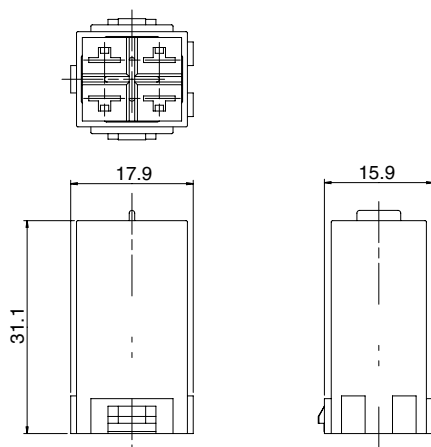

Part number	CL No.	RoHS
QR/P18-4P-C	CL221-0316-1	YES

● Female

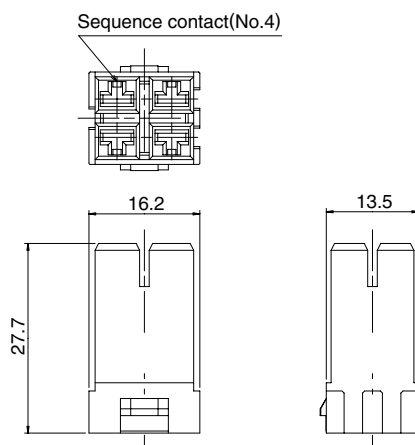

Part number	CL No.	RoHS
QR/P18-4S-C	CL221-0314-6	YES

■ Power contact

● Male contact

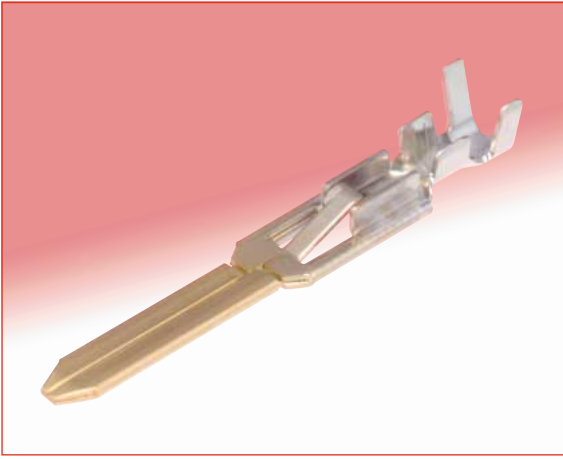

Part number	CL No.	Applicable cable	Packaging	Q'ty	RoHS
QR/P17-PCA-111(50)	CL221-0265-2-50	AWG16~18 UL1015	Bag	100	YES
QR/P17-PCA-211(50)	CL221-0263-7-50	AWG16~18 UL1015	Reel	3000	

Applicable cable: AWG#16 to 18, insulator diameter 2.1mm to 3.2mm

● Female contact

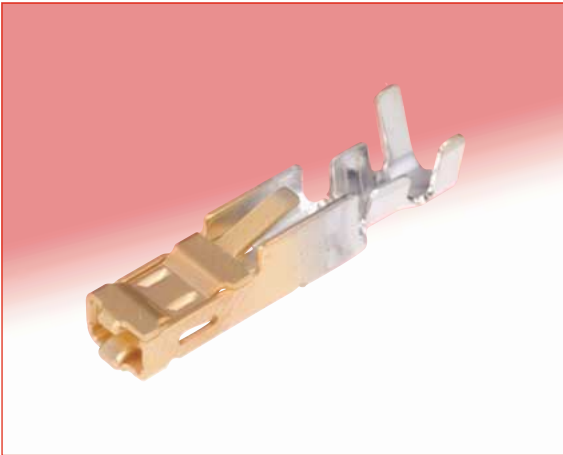

Part number	CL No.	Applicable cable	Packaging	Q'ty	RoHS
QR/P17-SCA-111(50)	CL221-0264-0-50	AWG16~18 UL1015	Bag	100	YES
QR/P17-SCA-211(50)	CL221-0262-4-50	AWG16~18 UL1015	Reel	3000	

Applicable cable: AWG#16 to 18, insulator diameter 2.1mm to 3.2mm

◆Tools

●Signal contact termination block IDC tool

Type	Part number	Applicable connector
Hand press for 12 pos.	QR/P18-12/IDCR-MP	QR/P18-12PA
		QR/P18-12SA
Hand press for 18 pos.	QR/P18-18/IDCR-MP	QR/P18-18PB
		QR/P18-18SB
Hand press for 24 pos.	QR/P18-24/IDCR-MP	QR/P18-24PC
		QR/P18-24SC
Automatic IDC applicator for male signal contact	2957-1000	QR/P18-12PA
		QR/P18-18PB
		QR/P18-24PC
Automatic IDC applicator for female signal contact	2957-1500	QR/P18-12SA
		QR/P18-18SB
		QR/P18-24SC

Automatic IDC machine (Murata kogyo co., Ltd., P/N MS-01) is available.

●Power contact crimp tool

Type	Part number	Applicable contact
Hand tool	HT104/QR/P17-1	QR/P17-PCA-111(50)
		QR/P17-SCA-111(50)
Applicable for automatic crimp machine	AP105-QR/P17-1	QR/P17-PCA-211(50)
	AP105-QR/P17-1	QR/P17-SCA-211(50)
Automatic crimp machine	CM-105	QR/P17-PCA-211(50)
		QR/P17-SCA-211(50)
Extraction tool	QR/P17-TC	QR/P17-PCA-111(50)
		QR/P17-SCA-111(50)
		QR/P17-PCA-211(50)
		QR/P17-SCA-211(50)

■ Inspection After Cable Wiring

● Signal contact unit

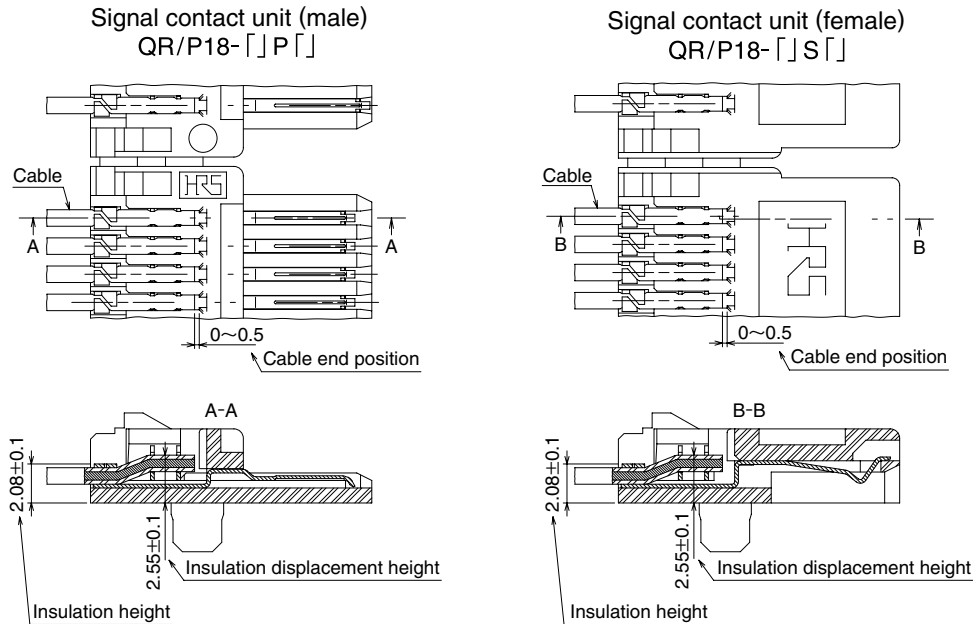

- (1) After wiring the cable, examine the cable end position, the insulation displacement height, and the insulation height.
- (2) In examining the insulation displacement height and the insulation height, use a measurement pin having a tip of 0.5 mm diameter.
- (3) For information about the detailed inspection method, please request the "Inspection Standards Manual" from Hirose Electric.
- (4) The inspection method of the diagrams is for cable with AWG #26 wire and an insulation outside diameter of 0.88 mm.

● Power supply contacts

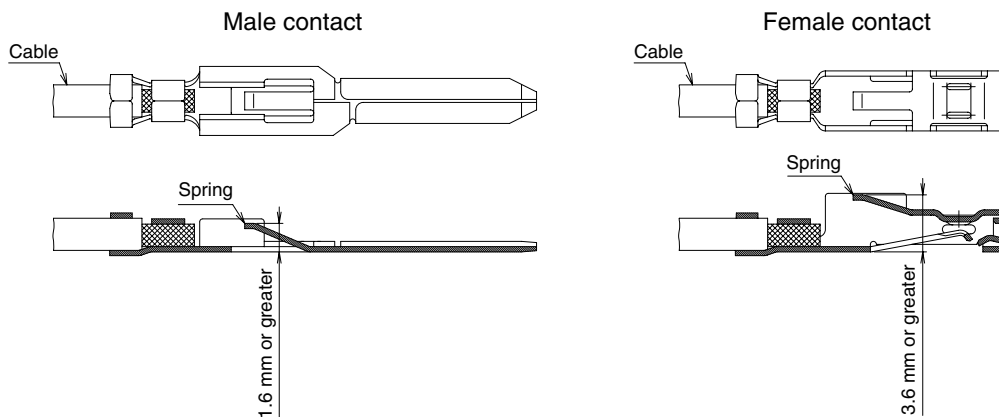

Before inserting the power supply contacts into the power supply terminal unit, check that the spring portion illustrated in the diagram is not misshapen.

When the spring portion is less than the dimensions indicated in the diagram, the spring could pull out from the power supply terminal unit; therefore, the specified dimensions should be maintained.



HIROSE ELECTRIC CO.,LTD.

5-23,OSAKI 5-CHOME,SHINAGAWA-KU,TOKYO 141-8587,JAPAN
 PHONE: 81-3-3491-9741, FAX: 81-3-3493-2933
<http://www.hirose.com>
<http://www.hirose-connectors.com>

Компания «Life Electronics» занимается поставками электронных компонентов импортного и отечественного производства от производителей и со складов крупных дистрибьюторов Европы, Америки и Азии.

С конца 2013 года компания активно расширяет линейку поставок компонентов по направлению коаксиальный кабель, кварцевые генераторы и конденсаторы (керамические, пленочные, электролитические), за счёт заключения дистрибьюторских договоров

Мы предлагаем:

- Конкурентоспособные цены и скидки постоянным клиентам.
- Специальные условия для постоянных клиентов.
- Подбор аналогов.
- Поставку компонентов в любых объемах, удовлетворяющих вашим потребностям.
- Приемлемые сроки поставки, возможна ускоренная поставка.
- Доставку товара в любую точку России и стран СНГ.
- Комплексную поставку.
- Работу по проектам и поставку образцов.
- Формирование склада под заказчика.
- Сертификаты соответствия на поставляемую продукцию (по желанию клиента).
- Тестирование поставляемой продукции.
- Поставку компонентов, требующих военную и космическую приемку.
- Входной контроль качества.
- Наличие сертификата ISO.

В составе нашей компании организован Конструкторский отдел, призванный помогать разработчикам, и инженерам.

Конструкторский отдел помогает осуществить:

- Регистрацию проекта у производителя компонентов.
- Техническую поддержку проекта.
- Защиту от снятия компонента с производства.
- Оценку стоимости проекта по компонентам.
- Изготовление тестовой платы монтаж и пусконаладочные работы.



Тел: +7 (812) 336 43 04 (многоканальный)

Email: org@lifeelectronics.ru