

HCPL-2533

Dual Channel, High Speed Logic Interface Optocoupler



Data Sheet



Description

The HCPL-2533 is a dual channel optocoupler which is specified for use in LSTTL-to-LSTTL and TTL-to-LSTTL logic interfaces. A nominal 8 mA LSTTL sink current through the input LED will provide enough output current for proper operation of 1 LSTTL gate under worst-case conditions when used in the recommended circuits. The CTR of the HCPL-2533 is 15% minimum at $I_F = 8$ mA.

The HCPL-2533 contains a pair of light emitting diodes and integrated photon detectors with a 3000 Vdc withstand test between input and output. Separate connection for the photodiode bias and output transistor collector reduce the base-collector capacitance, giving improved speed compared with conventional phototransistor couplers.

Features

- Data rates to 250 kb/s NRZ
- LSTTL compatible
- High common mode transient immunity: > 1000 V/ μ s
- High density packaging
- Open collection outputs
- Guaranteed performance from temperature: 0°C to 70°C
- Safety approval
 - UL Recognized - $3750V_{\text{rms}}$ for 1 min ($5000V_{\text{rms}}$ for 1 min Option 020 devices) per UL1577.
 - IEC/EN/DIN EN 60747-5-2 Approved
 - $V_{\text{ORM}} = 630 V_{\text{peak}}$ for option 060

Schematic

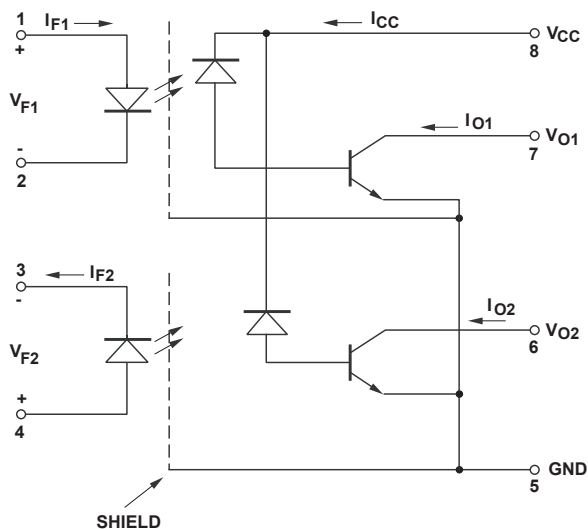

USE OF A $0.1 \mu\text{F}$ BYPASS CAPACITOR CONNECTED BETWEEN PINS 5 AND 8 IS RECOMMENDED.

Applications

- High speed logic ground isolation
 - LSTTL-to-LSTTL and TTL-to-LSTTL
- High voltage isolation
- Analog signal ground isolation

CAUTION: It is advised that normal static precautions be taken in handling and assembly of this component to prevent damage and/or degradation which may be induced by ESD.

Ordering Information

HCPL-2533 is UL Recognized with 3750 Vrms and 5000 Vrms (Option 020) for 1 minute per UL1577 and are approved under CSA Component Acceptance Notice #5, File CA 88324.

Part number	Option		Package	Surface Mount	Gull Wing	Tape & Reel	UL 5000 Vrms/ 1 Minute rating	IEC/EN/DIN EN 60747-5-2	Quantity
	RoHS Compliant	Non RoHS Compliant							
HCPL-2533	-000E	No option	300mil DIP-8						50 per tube
	-300E	-300		X	X				50 per tube
	-500E	-500		X	X	X			1000 per reel
	-020E	-020					X		50 per tube
	-320E	-320		X	X		X		50 per tube
	-520E	-520		X	X	X	X		1000 per reel
	-060E	-060						X	50 per tube
	-360E	-360		X	X			X	50 per tube
	-560E	-560		X	X	X		X	1000 per reel

To order, choose a part number from the part number column and combine with the desired option from the option column to form an order entry.

Example 1:

HCPL-2533-500E to order product of 300mil DIP Gull Wing Surface Mount package in Tape and Reel packaging with RoHS compliant.

Example 2:

HCPL-2533 to order product of 300mil DIP package in tube packaging and non RoHS compliant.

Option datasheets are available. Contact your Avago sales representative or authorized distributor for information.

Remarks: The notation '#XXX' is used for existing products, while (new) products launched since 15th July 2001 and RoHS compliant option will use '-XXxE'.

Absolute Maximum Ratings

Storage Temperature	-55°C to +125°C
Operating Temperature	-55°C to +100°C
Lead Solder Temperature (1.6 mm below seating plane)	260°C for 10 s
Average Input Current – I _F (each channel)	25 mA ^[1]
Peak Input Current – I _F (each channel) (50% duty cycle, 1 ms pulse width)	50 mA ^[2]
Peak Transient Input Current – I _F (each channel) (≤1 μs pulse width, 300 pps)	1.0 A
Reverse Input Voltage – V _R (each channel)	5 V
Input Power Dissipation (each channel)	45 mW ^[3]
Average Output Current – I _O (each channel)	8 mA
Peak Output Current – I _O (each channel)	16 mA
Supply and Output Voltage – V _{CC} (Pin 8-5), V _O (Pin 7, 6-5)	-0.5 V to 7 V
Output Power Dissipation (each channel)	35 mW ^[4]

Notes:

1. Derate linearly above +70°C free-air temperature at a rate of 0.8 mA/°C.
2. Derate linearly above +70°C free-air temperature at a rate of 1.6 mA/°C.
3. Derate linearly above +70°C free-air temperature at a rate of 0.9 mW/°C.
4. Derate linearly above +70°C free-air temperature at a rate of 1.0 mW/°C.

Solder Reflow Thermal Profile

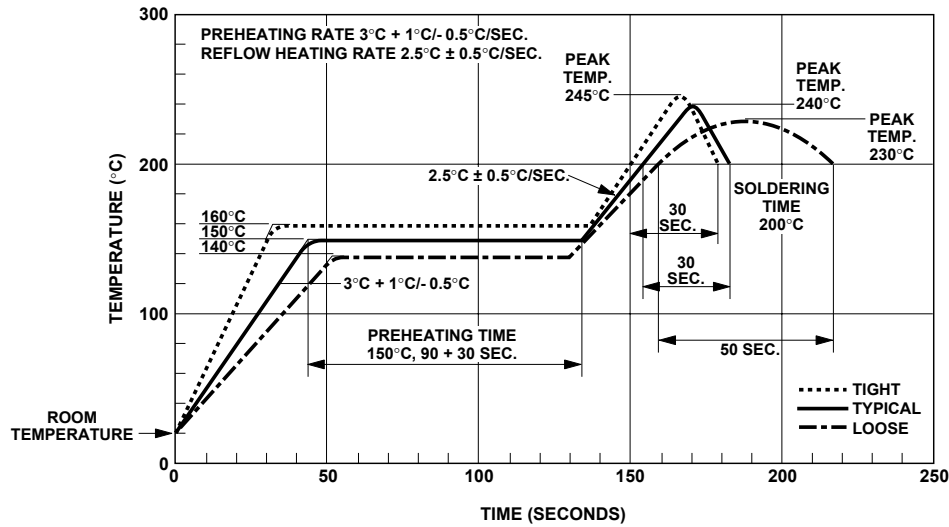

Note: Non-halide flux should be used.

Recommended Pb-Free IR Profile

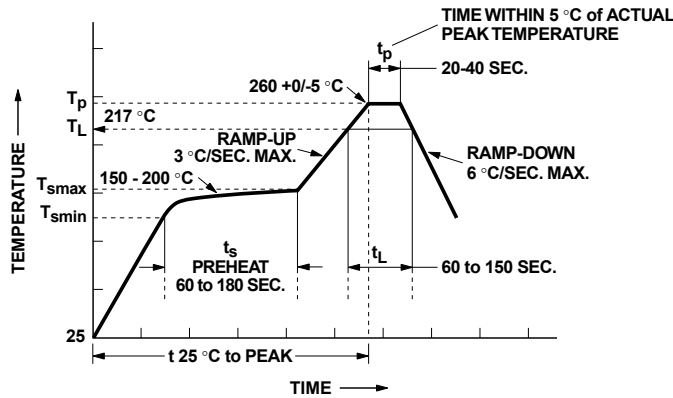

NOTES:
 THE TIME FROM 25°C TO PEAK TEMPERATURE = 8 MINUTES MAX.
 $T_{smax} = 200^{\circ}\text{C}$, $T_{smin} = 150^{\circ}\text{C}$

Note: Non-halide flux should be used.

Regulatory Information

The devices contained in this data sheet have been approved by the following organizations:

UL

Recognized under UL 1577, Component Recognition Program, File E55361.

CSA

Approved under CSA Component Acceptance Notice #5, File CA 88324.

IEC/EN/DIN EN 60747-5-2

Approved under:
 IEC 60747-5-2:1997 + A1:2002
 EN 60747-5-2:2001 + A1:2002
 DIN EN 60747-5-2 (VDE 0884 Teil 2):2003-01.
 (Option 060 only)

Insulation and Safety Related Specifications

Parameter	Symbol	Value	8-Pin DIP (300 Mil) Value	SO-8 Units	Conditions
Minimum External Air Gap (External Clearance)	L(101)	7.1	4.9	mm	Measured from input terminals to output to output terminals, shortest distance through air.
Minimum External Tracking (External Creepage)	L(102)	7.4	4.8	mm	Measured from input terminals to output terminals, shortest distance path along body.
Minimum Internal Plastic Gap (Internal Clearance)		0.08	0.08	mm	Through insulation distance, conductor to conductor, usually the direct distance between the photoemitter and photodetector inside the optocoupler cavity.
Minimum Internal Tracking (Internal Creepage)		NA	NA	mm	Measured from input terminals to output terminals, along internal cavity.
Tracking Resistance (Comparative Tracking Index)	CTI	200	200	Volts	DIN IEC 112/VDE 0303 Part 1
Isolation Group		IIIa	IIIa		Material Group (DIN VDE 0110, 1/89, Table 1)

Option 300 - surface mount classification is Class A in accordance with CECC 00802.

IEC/EN/DIN EN 60747-5-2 Insulation Characteristics (Option 060)

Description	Symbol	Characteristic HCPL-2533	Unit
Installation classification per DIN VDE 0110/1.89, Table 1 for rated mains voltage ≤ 150 V rms for rated mains voltage ≤ 300 V rms for rated mains voltage ≤ 600 V rms		I-IV I-III	
Climatic Classification		55/100/21	
Pollution Degree (DIN VDE 0110/1.89)		2	
Maximum Working Insulation Voltage	V_{IORM}	630	V_{peak}
Input to Output Test Voltage, Method b* $V_{IORM} \times 1.875 = V_{PR}$, 100% Production Test with $t_m = 1$ sec, Partial Discharge < 5 pC	V_{PR}	1181	V_{peak}
Input to Output Test Voltage, Method a* $V_{IORM} \times 1.5 = V_{PR}$, Type and Sample Test, $t_m = 60$ sec, Partial Discharge < 5 pC	V_{PR}	945	V_{peak}
Highest Allowable Overvoltage (Transient Overvoltage, $t_{ini} = 10$ sec)	V_{IOTM}	6000	V_{peak}
Safety Limiting Values (Maximum values allowed in the event of a failure.)			
Case Temperature	T_S	175	°C
Input Current**	$I_{S,INPUT}$	230	mA
Output Power**	$P_{S,OUTPUT}$	600	mW
Insulation Resistance at T_S , $V_{IO} = 500$ V	R_S	> 10^9	Ω

* Refer to the optocoupler section of the Isolation and Control Components Designer's Catalog, under Product Safety Regulations section, IEC/EN/DIN EN 60747-5-2, for a detailed description of Method a and Method b partial discharge test profiles.

** Refer to the following figure for dependence of P_S and I_S on ambient temperature.

Note: Isolation characteristics are guaranteed only within the safety maximum ratings, which must be ensured by protective circuits in application.

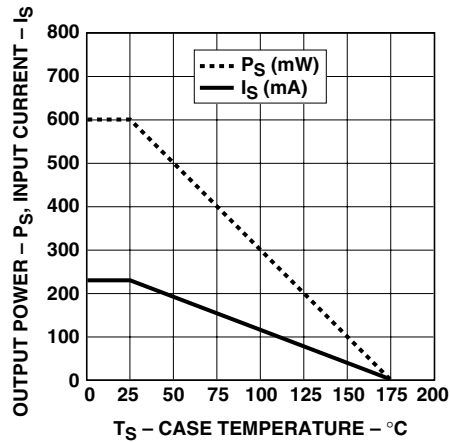

Electrical Specifications, LSTTL-to-LSTTL

Over recommended temperature ($T_A = 0^\circ\text{C}$ to $+70^\circ\text{C}$) unless otherwise specified.

Parameter	Symbol	Min.	Typ.*	Max.	Units	Test Conditions	Fig.	Note
Current Transfer Ratio	CTR	15	22		%	$I_F = 8\text{ mA}$, $V_O = 0.5\text{ V}$, $V_{CC} = 4.5\text{ V}$, $T_A = 25^\circ$	1	5,6
		11	15		%	$I_F = 8\text{ mA}$, $V_O = 0.5\text{ V}$, $V_{CC} = 4.5\text{ V}$		
Logic Low Output Voltage	V_{OL}		0.2	0.5	V	$I_F = 8\text{ mA}$, $I_O = 0.7\text{ mA}$, $V_{CC} = 4.5\text{ V}$		5
Logic Low Supply Current	I_{CCL}		40		μA	$I_{F1} = I_{F2} = 8\text{ mA}$ $V_{O1} = V_{O2} = \text{Open}$, $V_{CC} = 5.5\text{ V}$		
Input Forward Voltage	V_F		1.5	1.7	V	$I_F = 8\text{ mA}$, $T_A = 25^\circ\text{C}$	2	5
Temperature Coefficient of Forward Voltage	$\frac{\Delta V_F}{\Delta T_A}$		-1.6		$\text{mV}/^\circ\text{C}$	$I_F = 8\text{ mA}$		5

*All typicals at 25°C .

Switching Specifications at $T_A = 25^\circ\text{C}$

$V_{CC} = 5\text{ V}$, $I_F = 8\text{ mA}$, $R_L = 7.5\text{ k}\Omega$ unless otherwise specified.

Parameter	Symbol	Min.	Typ.	Max.	Units	Test Conditions	Fig.	Note
Propagation Delay Time to Logic Low at Output	t_{PHL}		0.8	1.5	μs		4,6	10
Propagation Delay Time to Logic High at Output	t_{PLH}		1.0	2.5	μs		4,6	10
Common Mode Transient Immunity at Logic High Level Output	CM_H		1000		$\text{V}/\mu\text{s}$	$I_F = 0\text{ mA}$, $V_{CM} = 10\text{ V}_{P-P}$	7	9,10
Common Mode Transient Immunity at Logic Low Level Output	CM_L		-1000		$\text{V}/\mu\text{s}$	$V_{CM} = 10\text{ V}_{P-P}$	7	9,10

Electrical Specifications, TTL-to-LSTTL

Over recommended temperature ($T_A = 0^\circ\text{C}$ to $+70^\circ\text{C}$) unless otherwise specified.

Parameter	Symbol	Min.	Typ.	Max.	Units	Test Conditions	Fig.	Note
Current Transfer Ratio	CTR	12	18		%	$I_F = 16\text{ mA}$, $V_O = 0.5\text{ V}$, $V_{CC} = 4.5\text{ V}$, $T_A = 25^\circ\text{C}$	1	5,6
		9	13		%	$I_F = 16\text{ mA}$, $V_O = 0.5\text{ V}$, $V_{CC} = 4.5\text{ V}$		
Logic Low Output Voltage	V_{OL}		0.2	0.5	V	$I_F = 16\text{ mA}$, $I_O = 1.1\text{ mA}$, $V_{CC} = 4.5\text{ V}$		5
Logic Low Supply Current	I_{CCL}		80		μA	$I_{F1} = I_{F2} = 16\text{ mA}$ $V_{O1} = V_{O2} = \text{Open}$, $V_{CC} = 5.5\text{ V}$		
Input Forward Voltage	V_F		1.5	1.7	V	$I_F = 16\text{ mA}$, $T_A = 25^\circ\text{C}$	2	5
Temperature Coefficient of Forward Voltage	$\frac{\Delta V_F}{\Delta T_A}$		-1.6		$\text{mV}/^\circ\text{C}$	$I_F = 16\text{ mA}$		5

*All typicals at 25°C .

Switching Specifications at $T_A = 25^\circ\text{C}$

$V_{CC} = 5\text{ V}$, $I_F = 16\text{ mA}$, $R_L = 4.7\text{ k}\Omega$ unless otherwise specified.

Parameter	Symbol	Min.	Typ.	Max.	Units	Test Conditions	Fig.	Note
Propagation Delay Time to Logic Low at Output	t_{PHL}		0.3	1.5	μs		4,6	11
Propagation Delay Time to Logic High at Output	t_{PLH}		1.1	2.5	μs		4,6	11
Common Mode Transient Immunity at Logic High Level Output	CM_H		1000		$\text{V}/\mu\text{s}$	$I_F = 0\text{ mA}$, $V_{CM} = 10\text{ V}_{P-P}$	7	9,11
Common Mode Transient Immunity at Logic Low Level Output	CM_L		-1000		$\text{V}/\mu\text{s}$	$V_{CM} = 10\text{ V}_{P-P}$	7	9,11

Electrical Specifications

Over recommended temperature ($T_A = 0^\circ\text{C}$ to $+70^\circ\text{C}$) unless otherwise specified.

Parameter	Symbol	Min.	Typ.*	Max.	Units	Test Conditions	Fig.	Note
Logic High Output Current	I_{OH}		0.5		nA	$T_A = 25^\circ\text{C}$, $I_{F1} = I_{F2} = 0\text{ mA}$ $V_{O1} = V_{O2} = V_{CC} = 5.5\text{ V}$	5	5
					50	μA	$I_{F1} = I_{F2} = \text{mA}$ $V_{O1} = V_{O2} = V_{CC} = 5.5\text{ V}$	
Logic High Supply Current	I_{CCH}		0.05	4	μA	$I_{F1} = I_{F2} = 0\text{ mA}$ $V_{O1} = V_{O2} = \text{Open}$, $V_{CC} = 5.5\text{ V}$		
Input Reverse Breakdown Voltage	V_R	5			V	$I_F = 10\ \mu\text{A}$, $T_A = 25^\circ\text{C}$		5
Input Capacitance	C_{IN}		60		pF	$f = 1\text{ MHz}$, $V_F = 0\text{ V}$		5
Input-Output Insulation Leakage Current	I_{I-O}			1.0	μA	45% Relative Humidity, $t = 5\text{ s}$ $V_{I-O} = 3000\text{ Vdc}$, $T_A = 25^\circ\text{C}$		7
Resistance (Input-Output)	R_{I-O}		10^{12}		Ω	$V_{I-O} = 500\text{ Vdc}$		7
Capacitance (Input-Output)	C_{I-O}		0.6		pF	$f = 1\text{ MHz}$		7
Input-Input Insulation Leakage Current	I_{I-I}		0.005		μA	45% Relative Humidity, $t = 5\text{ s}$ $V_{I-I} = 500\text{ Vdc}$		8
Resistance (Input-Input)	R_{I-I}		10^{11}		Ω	$V_{I-I} = 500\text{ Vdc}$		8
Capacitance (Input-Input)	C_{I-I}		0.25		pF	$f = 1\text{ MHz}$		8

*All typicals at 25°C .

Notes:

5. Each channel.
6. Current Transfer Ratio is defined as the ratio of output collector current, I_O , to the forward LED input current, I_F , times 100%.
7. Device considered a two-terminal device: Pins 1, 2, 3, and 4 shorted together and Pins 5, 6, 7, and 8 shorted together.
8. Measured between pins 1 and 2 shorted together, and pins 3 and 4 shorted together.
9. Common mode transient immunity in Logic High level is the maximum tolerable (positive) dV_{CM}/dt on the leading edge of the common mode pulse V_{CM} , to assure that the output will remain in a Logic High state (i.e., $V_O > 2.0\text{ V}$). Common mode transient immunity in Logic Low level is the maximum tolerable (negative) dV_{CM}/dt on the trailing edge of the common mode pulse signal, V_{CM} , to assure that the output will remain in a Logic Low state (i.e., $V_O < 0.8\text{ V}$).
10. The 7.5 k load represents 1 LSTTL unit load of 0.36 mA and a 20 k Ω pull-up resistor.
11. The 4.7 k load represents 1 LSTTL unit load of 0.36 mA and an 8.2 k Ω pull-up resistor.

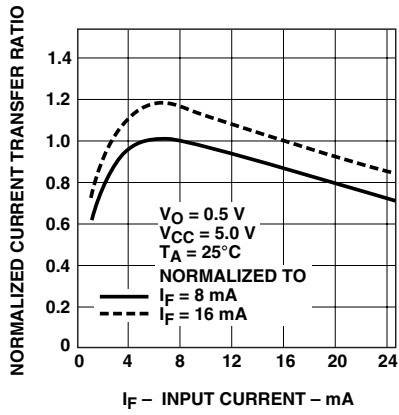

Figure 1. Current transfer ratio vs. input current

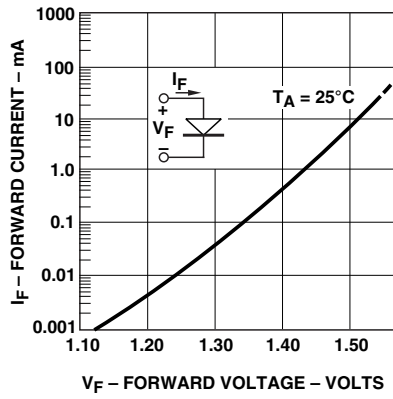

Figure 2. Input current vs. forward voltage

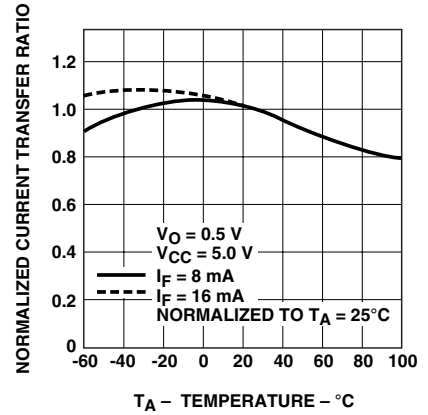

Figure 3. Current transfer ratio vs. temperature

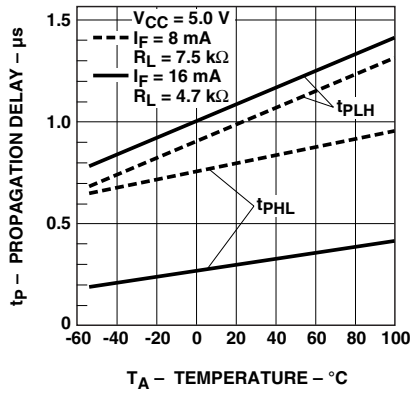

Figure 4. Propagation delay vs. temperature

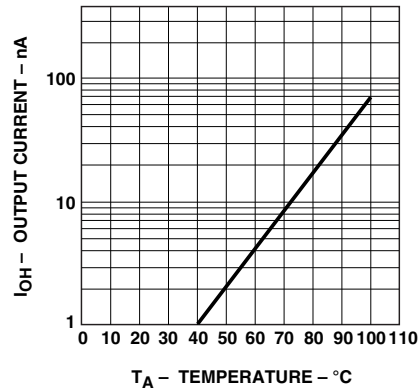

Figure 5. Logic high output current vs. temperature

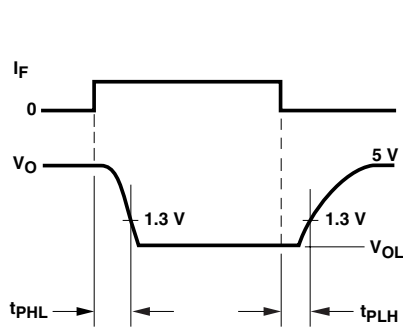
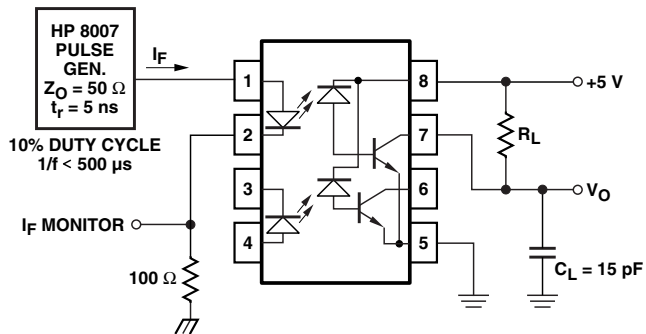

Figure 6. Switching test circuit



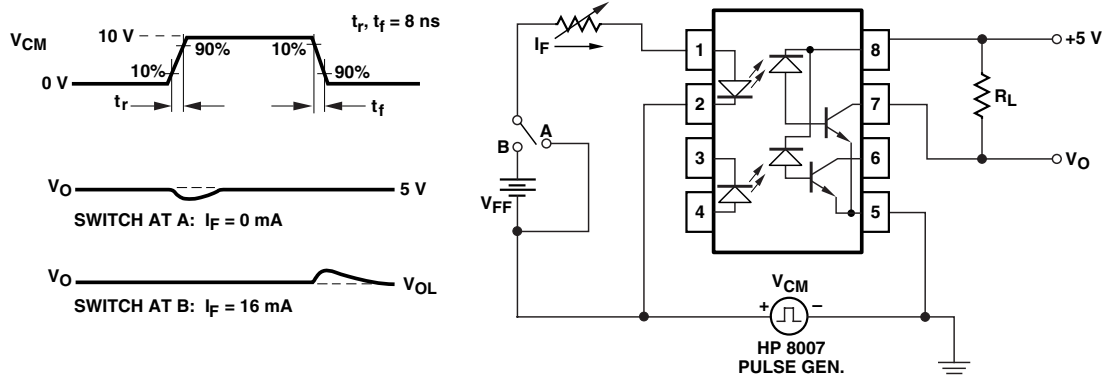

Figure 7. Test circuit for transient immunity and typical waveforms

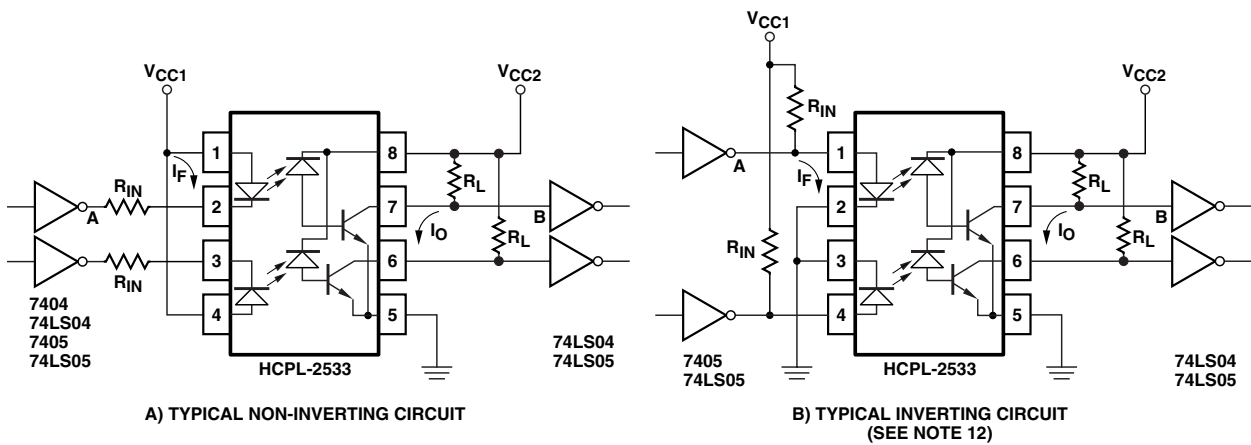

Figure 8. Recommended circuits

Recommended Operation

The HCPL-2533 optocoupler is specified for use in LSTTL-to-LSTTL and TTL-to-LSTTL interfaces. The recommended circuits show the interface design and give suggested component values. The input current I_F is given as both a nominal value and a range. The range in I_F results from the tolerances in V_{CC} and the input resistor R_{IN} . The CTR of the optocoupler is given as the minimum

initial value over temperature, taken directly from the Electrical Specifications. The value given for $I_{OL}(\min)$ is based on the minimum CTR and the minimum I_F using worst case values for R_L and V_{CC} . The resulting $I_{OL}(\min)$ has ample design margin, allowing more than 20% for CTR degradation even under these worst case conditions. For additional information on CTR degradation see *Application Note 1002*.

Recommended Circuit Design Parameters

Parameter	Symbol	LSTTL	LSTTL-to-LSTTL	TTL-to-Units	Comments	Fig.	Note
Input							
Logic Low Output Voltage – Input Gate	$V_{OL(A)}$	0.5	0.4	V	Maximum		
Supply Voltage – Input	V_{CC1}	5.0	5.0	V	$\pm 5\%$		
Input Resistor	R_{IN}	360	180	Ω	$\pm 5\%$		8a
		430	200				8b
Input Current	I_F	8	16	mA	Nominal		
Input Current Range	I_F	6.75–10	14.0–20	mA			8a
			14.5–20				8b
Output							
Logic Low Output Voltage – HCPL-2533	$V_{OL(B)}$	0.5	0.5	V	Maximum		
Supply Voltage – Input	V_{CC2}	5.0	5.0	V	$\pm 5\%$		
Pull-Up Resistor	R_L	20	8.2	$k\Omega$	$\pm 5\%$		13
Required Current Sink for Logic Low	$I_{OL(max)}$	0.61	1.0	mA	Worst Case V_{CC} , R_L , $I_{IL(B)}$		14
HCPL-2533 Current Transfer Ratio	CTR	11	9	%	Minimum $T_A = 0^\circ\text{C}$ to $+70^\circ\text{C}$		
Logic Low Output Current – HCPL-2533	$I_{OL(min)}$	0.74	1.26	mA	Worst Case V_{CC} , CTR, I_F , $T_A = 0^\circ\text{C}$ to $+70^\circ\text{C}$		8a
			1.30				8b
Data Rate	f_D	250	250	Kb/s	NRZ, $T_A = 25^\circ\text{C}$		16

Notes:

12. The inverting circuit has higher power consumption and must use open collector gates on the input.
 13. The load resistor R_L must be large enough to guarantee logic LOW and small enough to guarantee logic HIGH under worst case conditions:

$$\frac{V_{CC(max)} - V_{OL}}{I_{OL(2533)} - I_{IL(B)}} \leq R_L \leq \frac{V_{CC(min)} - V_{IH(B)}}{I_{OH(2533)} - I_{IH(B)}}$$

The selection of R_L is the same for both inverting and non-inverting circuits.

14. The maximum current sink required for logic LOW is:

$$I_{OL(max)} = I_{IL(B)(max)} + I_R(max)$$

where I_R is the current through R_L .

15. The ratio of $I_{OL(min)}$ to $I_{OL(max)}$ gives the design margin for CTR degradation. See Application Note 1002.
 16. The maximum data rate is defined as:

$$f_D = \frac{1}{t_{PHL} + t_{PLH}} \text{ bits/second NRZ}$$

For product information and a complete list of distributors, please go to our website: www.avagotech.com

Avago, Avago Technologies, and the A logo are trademarks of Avago Technologies Limited in the United States and other countries. Data subject to change. Copyright © 2007 Avago Technologies Limited. All rights reserved. Obsoletes 5953-0458 AV02-0521EN - June 19, 2007

Avago
TECHNOLOGIES

Компания «Life Electronics» занимается поставками электронных компонентов импортного и отечественного производства от производителей и со складов крупных дистрибьюторов Европы, Америки и Азии.

С конца 2013 года компания активно расширяет линейку поставок компонентов по направлению коаксиальный кабель, кварцевые генераторы и конденсаторы (керамические, пленочные, электролитические), за счёт заключения дистрибьюторских договоров

Мы предлагаем:

- Конкурентоспособные цены и скидки постоянным клиентам.
- Специальные условия для постоянных клиентов.
- Подбор аналогов.
- Поставку компонентов в любых объемах, удовлетворяющих вашим потребностям.
- Приемлемые сроки поставки, возможна ускоренная поставка.
- Доставку товара в любую точку России и стран СНГ.
- Комплексную поставку.
- Работу по проектам и поставку образцов.
- Формирование склада под заказчика.
- Сертификаты соответствия на поставляемую продукцию (по желанию клиента).
- Тестирование поставляемой продукции.
- Поставку компонентов, требующих военную и космическую приемку.
- Входной контроль качества.
- Наличие сертификата ISO.

В составе нашей компании организован Конструкторский отдел, призванный помогать разработчикам, и инженерам.

Конструкторский отдел помогает осуществить:

- Регистрацию проекта у производителя компонентов.
- Техническую поддержку проекта.
- Защиту от снятия компонента с производства.
- Оценку стоимости проекта по компонентам.
- Изготовление тестовой платы монтаж и пусконаладочные работы.



Тел: +7 (812) 336 43 04 (многоканальный)

Email: org@lifeelectronics.ru