

Features

- Intel® Core™ i7/i5/i3 Processor with Mobile Intel® QM57 Express Chipset
- Up to 8 GB Dual Channel DDR3 SDRAM at 1066 MHz (optional ECC)
- Six PCIe x1, one PCIe x16 for graphics (or general purpose x8/4/1)
- 18/24-bit LVDS and Embedded DisplayPort
- SATA 3 Gb/s IDE (PATA), Gigabit Ethernet, USB 2.0

Specifications

Core System

CPU	Intel® Core™ i7-610E Processor (4M Cache, 2.53 GHz) 35 W Intel® Core™ i5-520E Processor (3M Cache, 2.40 GHz) 35 W Intel® Core™ i7-620LE Processor (4M Cache, 2.00 GHz) 25 W Intel® Core™ i7-620UE Processor (4M Cache, 1.06 GHz) 18 W Intel® Core™ i3-330E Processor (3M Cache, 2.13 GHz) 35W Intel® Celeron® Processor P4505 (2M Cache, 1.86 GHz) 35 W Intel® Celeron® Processor U3405 (2M Cache, 1.06GHz) 18W
-----	---

Memory	Dual channel 800/1066 MHz DDR3 memory up to 8 GB in dual stacked SODIMM socket; ECC memory for CBE series only
--------	--

Chipset	Mobile Intel® QM57 Express Chipset
L2 Cache	2 MB (Celeron® M), 4/3 MB (Intel® Core™ i7 / i5)
BIOS	AMI EFI with CMOS backup in 16 Mbit SPI flash
Hardware Monitor	Supply voltages and CPU temperature
Watchdog Timer	Programmable timer ranges to generate RESET
Expansion Busses	PCI Express x16 bus for discrete graphics solution or general purpose PCI Express (2 x8 or 2 x4 or 2 x1) or Embedded Display Port (eDP) 7 PCI Express x1: Lanes 0/1/2/3/4/5 are free, lane 6 is occupied by GbE; can be optionally configured as 1 PCIe x4 (on 0/1/2/3) and 2 PCIe x1 (4/5) 32-bit PCI: PCI Rev. 2.3 at 33MHz, supporting 4 bus masters LPC bus, SMBus (system), I ² C (user)

Video

Integrated in Processor	Gen 5.75 with 12 execution units
Integrated Video Feature Support	DirectX 10 and OpenGL 2.1 Intel® Dynamic Video Memory Technology (Intel® DVMT 5.0) Video capture via x1 concurrent PCI Express port PAVP (Protected Audio-Video Path) support for Protected Intel HD Audio Playback High performance MPEG-2 decoding WMV9 (VC-1) and H.264 (AVC) support Hardware acceleration for MPEG2 VLD/IDCT Microsoft DirectX 10 support OpenGL 2.1 support Blu-ray support @ 40 Mb/s Hardware motion compensation Intermediate Z in classic rendering
VGA	Analog VGA support by 300 MHz DAC Analog monitor support up to QXGA (2048 X 1536)
LVDS	Single / Dual channel 18/24-bit panels

Audio

Chipset	Integrated in Intel® PCH QM57
Audio Codec	On Express-BASE carrier (ALC886)

Ethernet

Chipset	Integrated in Mobile QM57 with 82577LM PHY
Interface	10/100/1000 Mbps Ethernet

I/O Interfaces

Chipset	Integrated on Intel® PCH QM57
USB	Supports up to eight ports USB v. 2.0
SATA	Four ports SATA 3 Gb/s with optional support for RAID 0,1,5,10
PATA	SATA to PATA bridge on SATA channel 1, Master only

Super I/O

Connected to LPC bus on carrier if needed

TPM (optional)

Chipset	Infineon SLB9635TT1.2
Type	TPM 1.2

Power

Input Power	AT mode (12 V +/- 5%) and ATX mode (12 V and 5 Vsb +/- 5%)
Power States	Supports S0, S1, S3, S4, S5
Power Consumption	21 W with Core™ i7-620UE at 1.2 GHz and 2 GB memory typical
Smart Battery Support	Yes

Mechanical and Environmental

Dimension	Basic size: 125 mm x 95 mm
Operating Temperature	Standard: 0°C to +60°C
Storage Temperature	-20°C to +80°C
Humidity	90% at +60°C
Shock	15G peak-to-peak, 11ms duration, non-operation
Vibration	Non-operating: 1.88 Grms, 5-500 Hz, each axis Operating: 0.5 Grms, 5-500 Hz, each axis
Compatibility	COM Express® Type 2, Basic form factor 125 mm x 95 mm
Certification	CE, FCC

Operating Systems

Standard Support	Windows XP(e), Vista, Windows 7, Linux
Extended Support (BSP)	Embedded XP support package, Linux 2.6.x BSP, VxWorks 6.x BSP, AIDI Library for Windows and Linux

Functional Diagram

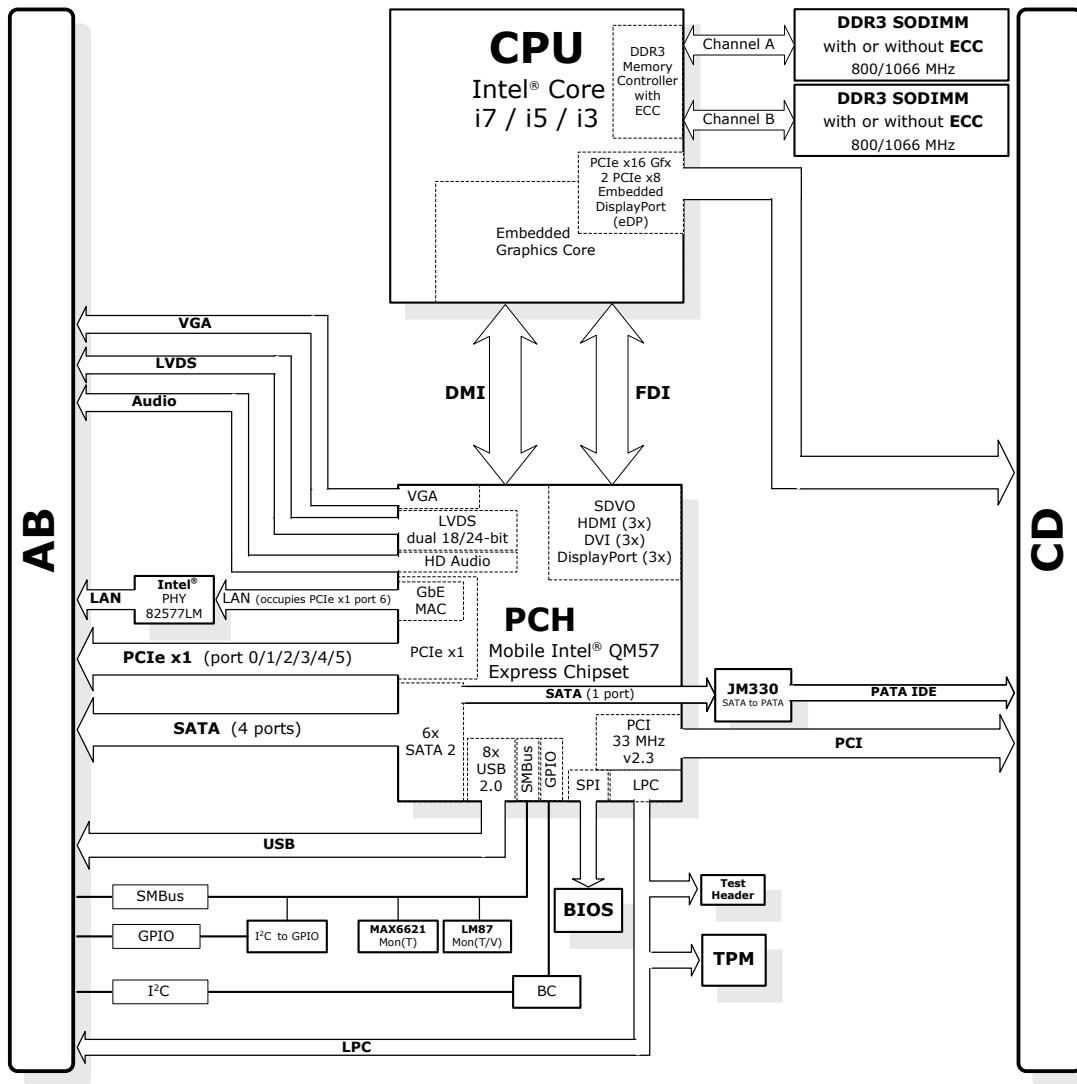

Ordering Information

Modules

Non-ECC Model Number	ECC Model Number	Description/Configuration
Express-CB-i3-330E	Express-CBE-i3-330E	COM Express® Basic Size Type 2 Module with Intel® Core™ i3-330E SV at 2.13 GHz
Express-CB-i5-520E	Express-CBE-i5-520E	COM Express® Basic Size Type 2 Module with Intel® Core™ i5-520 SV at 2.4 GHz
Express-CB-i7-610E	Express-CBE-i7-610E	COM Express® Basic Size Type 2 Module with Intel® Core™ i7-610E SV at 2.53 GHz
Express-CB-i7-620LE	Express-CBE-i7-620LE	COM Express® Basic Size Type 2 Module with Intel® Core™ i7-620LE LV at 2.0 GHz
Express-CB-i7-620UE	Express-CBE-i7-620UE	COM Express® Basic Size Type 2 Module with Intel® Core™ i7-620UE ULV at 1.07 GHz
Express-CB-U3405	Express-CBE-U3405	COM Express® Basic Size Type 2 Module with Intel® Celeron® U3405 ULV at 1.06 GHz
Express-CB-P4505	Express-CBE-P4505	COM Express® Basic Size Type 2 Module with Intel® Celeron® P4505 SV at 1.86 GHz

Accessories

Model Number	Description/Configuration
Heat Spreader	
HTS-CB-B	Heatspreader with threaded standoffs for Express-CB/CBE
HTS-CB-BT	Heatspreader with thouth hole for top mounting for Express-CB/CBE
Active Heatsink	
THSF-CB-B	Heatsink with fan and threaded standoffs for Express-CB/CBE

Note: All specifications are subject to change without further notice.

Компания «Life Electronics» занимается поставками электронных компонентов импортного и отечественного производства от производителей и со складов крупных дистрибьюторов Европы, Америки и Азии.

С конца 2013 года компания активно расширяет линейку поставок компонентов по направлению коаксиальный кабель, кварцевые генераторы и конденсаторы (керамические, пленочные, электролитические), за счёт заключения дистрибьюторских договоров

Мы предлагаем:

- Конкурентоспособные цены и скидки постоянным клиентам.
- Специальные условия для постоянных клиентов.
- Подбор аналогов.
- Поставку компонентов в любых объемах, удовлетворяющих вашим потребностям.
- Приемлемые сроки поставки, возможна ускоренная поставка.
- Доставку товара в любую точку России и стран СНГ.
- Комплексную поставку.
- Работу по проектам и поставку образцов.
- Формирование склада под заказчика.
- Сертификаты соответствия на поставляемую продукцию (по желанию клиента).
- Тестирование поставляемой продукции.
- Поставку компонентов, требующих военную и космическую приемку.
- Входной контроль качества.
- Наличие сертификата ISO.

В составе нашей компании организован Конструкторский отдел, призванный помогать разработчикам, и инженерам.

Конструкторский отдел помогает осуществить:

- Регистрацию проекта у производителя компонентов.
- Техническую поддержку проекта.
- Защиту от снятия компонента с производства.
- Оценку стоимости проекта по компонентам.
- Изготовление тестовой платы монтаж и пусконаладочные работы.



Тел: +7 (812) 336 43 04 (многоканальный)

Email: org@lifeelectronics.ru