

Single Cable Connection to PLC Means Space is Saved and Less Control Panel Wiring is Required.

- Compact size: 182 (W) × 85 (D) × 68 (H) mm (8-point Output Block width is 102 mm).
- Connects to the PC through the connecting cable (G79 Series) and connector, and requires only a snap-in operation.
- Surge suppressor circuit built-in.
- Immediate recognition of I/O signal status using LED operation indicators.
- G3TA I/O Solid-state relay can be mounted instead of G7T.
- Mounts easily on a DIN track.
- Approved by UL, CSA (except for G7TC-OC16-1).

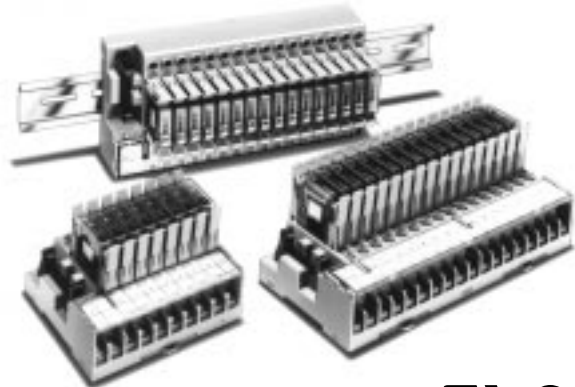

Ordering Information

Model Number Legend

A G7TC I/O Block is a combination of (8 or 16) G7T I/O Relays with SPST-NO specifications and a P7TF I/O Terminal.

G7TC-□□□□-□
 1 2 3 4

1. Input/Output Classification

- I : For input
- O : For output

2. Type of I/O Signal

- A : AC coil type for input relays mounted (Input/Output Classification: I)
- D : DC coil type for input relays mounted (Input/Output Classification: I)
- C : Contact output for output relays mounted (Input/Output Classification: O)

3. Number of I/O Points

- 16: 16 points
- 08: 8 points (for output only)

4. Internal I/O Circuit Common

- Blank: NPN
- 1: PNP

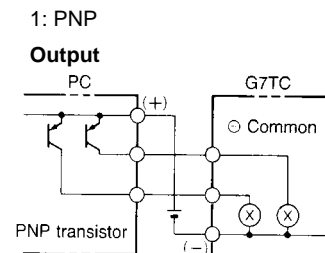
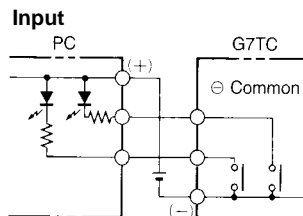
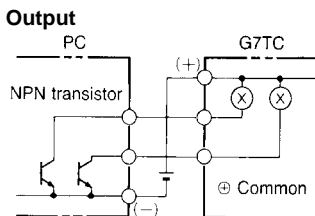

I/O Block

I/O classification	I/O points	Internal I/O circuit common	Rated voltage	Model	
Input	16	NPN (– common)	12 VDC	G7TC-ID16	
			24 VDC		
			100/110 VDC		
			100/110 VAC		G7TC-IA16
			200/220 VAC		
Output	16	NPN (+ common)	12 VDC	G7TC-OC16	
			24 VDC		
		PNP (– common)	12 VDC	G7TC-OC16-1 (see note 1)	
			24 VDC		
	8	NPN (+ common)	12 VDC	G7TC-OC08	
			24 VDC		
			24 VDC		

- Note:** 1. Not approved by UL, CSA.
 2. When ordering, add the rated coil voltage to the model number.
 Example: G7TC-ID16 24 VDC
 └─ Rated coil voltage

Specifications

■ Coil Ratings (Common to Input/Output per Relay)

Item	Rated current (mA)	Coil resistance (Ω)	Must operate	Must release	Maximum voltage	Power consumption			
						50 Hz	60 Hz	of rated voltage	per Relay
AC	100/110	8.2	7/7.7	8,700	80% max.	30% min.	105%	0.7 VA	11 VA
	200/220	4.1	3.5/3.85						
DC	12	42	290	80% max.	10% min.	105%	0.5 W	8 W	
	24	21							1,150
	100/110	5							20,000

- Note:** 1. The rated current and coil resistance are measured at a coil temperature of +23°C with a tolerance of +15%/–20% for AC rated current and ±15% for coil resistance.
 2. The operating characteristics are measured at a coil temperature of +23°C.
 3. The value for maximum voltage is the maximum value within the allowable voltage fluctuation range for the relay coil's operating power supply. Continuous operation at this voltage is not within product specifications.
 4. Approx. 4 mA flows into each LED indicator. To calculate the power supply capacity, add the current value of each LED indicator.

■ Contact Ratings (G7T I/O Relay)

Classification	For input		For output	
	Resistive load (cosφ=1)	Inductive load (cosφ=0.4 L/R=7 ms)	Resistive load (cosφ=1)	Inductive load (cosφ=0.4 L/R=7 ms)
Rated load	1 A at 24 VDC	0.5 A at 24 VDC	5 A at 24 VDC 2 A at 220 VAC	2 A at 24 VDC 1 A at 220 VAC
Rated carry current	1 A		5 A	
Max. switching voltage	250 VAC, 125 VDC			
Max. switching current	1 A	0.5 A	5 A	2 A
Error rate (reference value) (See note.)	100 μA at 1 V		10 mA at 5 V	
Electrical life expectancy	10,000,000 operations (at 10 mA) 50,000 operations (at 1 A)	2,500,000 operations (at 10 mA) 20,000 operations (at 1 A)	1,000,000 operations (under rated load)	
Mechanical life expectancy	50,000,000 operations			

- Note:** The above values are for a switching frequency of 120 operations/min.

■ Characteristics

Model		G7TC-IA16 (Input, AC coil)	G7TC-ID16 (Input, DC coil)	G7TC-OC16 (-1) (output, DC coil)	G7TC-OC08 (output, DC coil)
Item					
Contact form		SPST-NO × 16			SPST-NO × 8
Contact mechanism		Bifurcated crossbar contact		Single contact	
Contact material		Au cladding + Ag		AgInSn	
Contact resistance (See note 2.)		50 mΩ max.			
Must Operate time (See note 3.)		15 ms max.			
Release time (See note 3.)		15 ms max.			
Max. switching frequency	Mechanical limit	18,000 operations/hour			
	At rated load	1,800 operations/hour			
Insulation resistance		100 MΩ (at 500 VDC)			
Dielectric strength	Between coil and contact	2,000 VAC, 50/60 Hz for 1 minute			
	Between same polarity contacts	1,000 VAC, 50/60 Hz for 1 minute			
	Between paired connectors	250 VAC, 50/60 Hz for 1 minute			
Vibration resistance		10 to 55 to 10 Hz with 0.5-mm single amplitude (1.0-mm double amplitude)			
Shock resistance		200 m/s ²			
Noise immunity		Noise level: 1.5 kV; pulse width: 100 ns to 1 μs			
Rated voltage between positive and negative terminal blocks		Rated voltage of controller's (PLC or other) input circuit		12 VDC ± 5% 24 VDC ± 5%	
Rated current between positive and negative terminal blocks		Input circuit current of controller (PLC or other) × number of ON points		12 VDC: 46 mA × number of ON points 24 VDC: 25 mA × number of ON points	
Cable length (See note 4.)	To controller	5 m max. (reference value)			
	To I/O devices	50 m max. (reference value, for 2-mm ² CVV cable)		Dependent on load	
Ambient operating temperature		0 to 55°C			
Ambient operating humidity		35% to 85% (with no icing or condensation)			
Tightening torque for external connections		0.78 to 1.18 N·m			
Tensile strength		No damage when a tensile force of 49 N is applied in each direction. In the direction of the track, the tensile strength is 9.8 N min.			
I/O terminal tightening torque		Tightening strength: 0.98 N·m; Tensile strength 49 N per minute			
LED color		Red	Green		
Case color		Transparent red	Transparent green	Transparent green	
Coil surge absorber		Varistor	Diode (1 A, 400 V)		
Weight		Approx. 640 g	Approx. 630 g	Approx. 670 g	Approx. 350 g

- Note:**
1. The above values are initial values.
 2. Measurement condition: 1 A at 5 VDC.
 3. Ambient temperature: 23°C.
 4. Connecting cables up to 5 m are available as standard products. For longer cables, enquire separately.

UL and CSA Standards

Standard G7TC I/O Blocks, except for the G7TC-OC16-1 and the G7TC-OC08, have met UL and CSA standards (UL file no. E95399; CSA file no. LR35535).

Note that the following UL- and CSA-qualifying ratings differ from the performance characteristics of the individual models:

Model	Coil ratings	Contact ratings
G7TC-ID16, G7TC-IA16	10 mA/point, 24 VDC	250 VAC max.
G7TC-OC16	Coil drive current, 24 VDC	Inductive load: 10 A, 250 VAC Resistive load: 10 A, 30 VDC Rated horsepower: 1/2 HP, 240 VAC

Engineering Data

Life Expectancy of Output

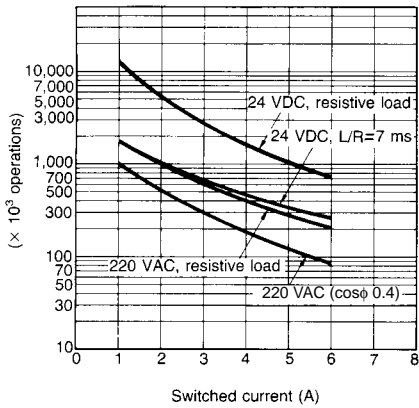

Max. Switching Capacity of Output
(Life expectancy : 1,000,000 Operations)

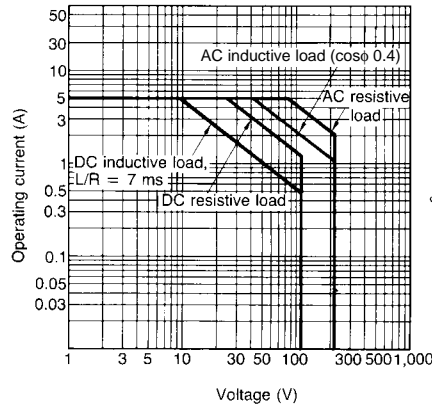

Life Expectancy of Input

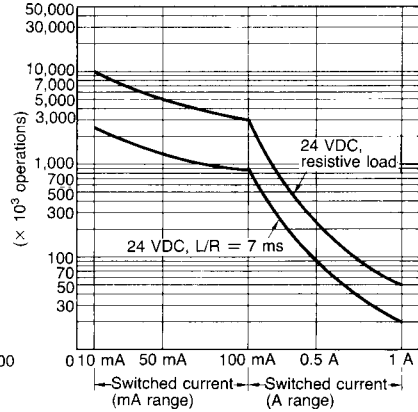

Example for Output Block (for Reference)

If a G7T I/O Relay is mounted in every other position on an Output Block (see drawing), a resistive load of 10 A (24 VDC) can be switched. Note that the service life is reduced to 150,000 operations in this case.

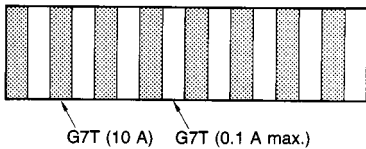

Load Current vs. Ambient Temperature

G3TA-OA202SZ
G3TA-OA202SL
G3TA-ODX02S

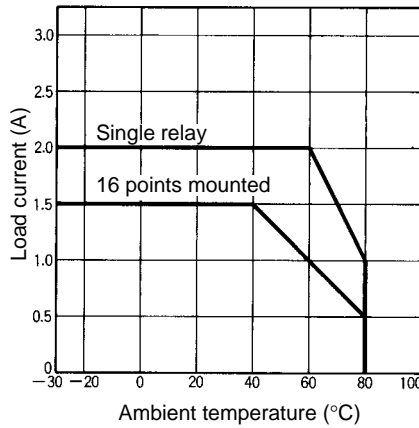

G3TA-OA201S

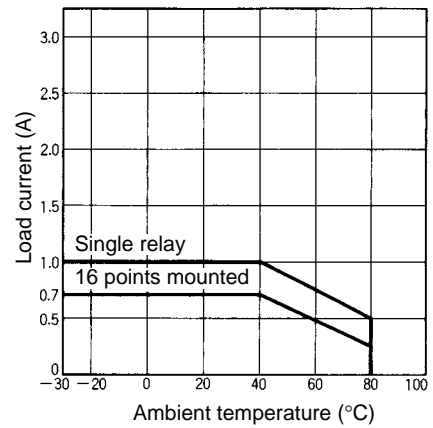

Inrush Current

The following graphs show the maximum inrush currents that can be withstood for non-repetitive operation. For repetitive operation, the figures should be reduced by half.

G3TA-OA202SZ
G3TA-OA202SL

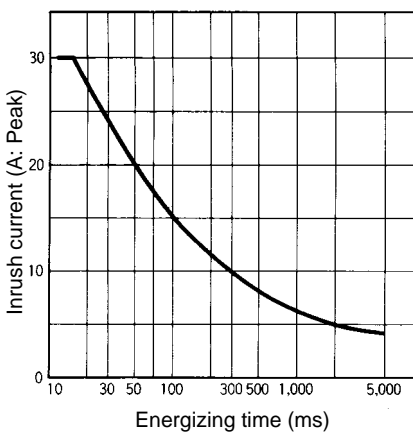

G3TA-ODX02S

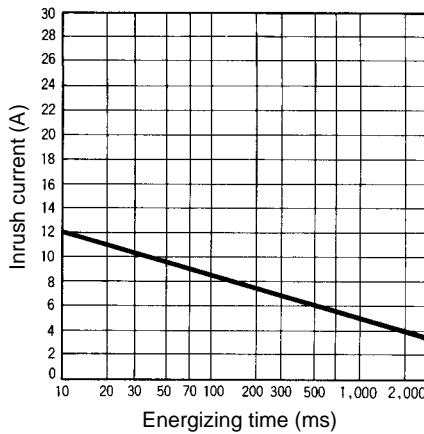

G3TA-OD201S

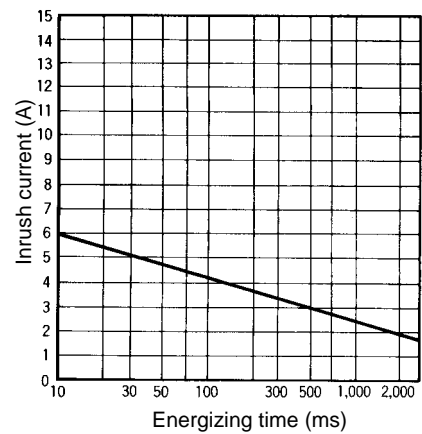

Cable Length

The following graph gives reference values for the relationship between cable length and voltage in the case where the voltage fluctuation of the power supply is 5%.

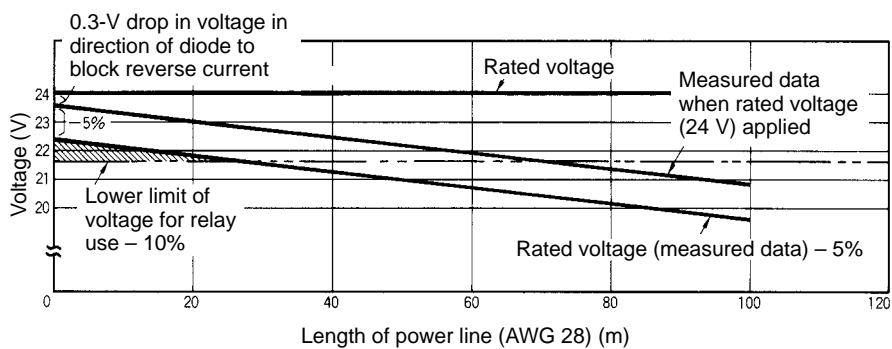

Dimensions

G7TC-ID16
G7TC-IA16

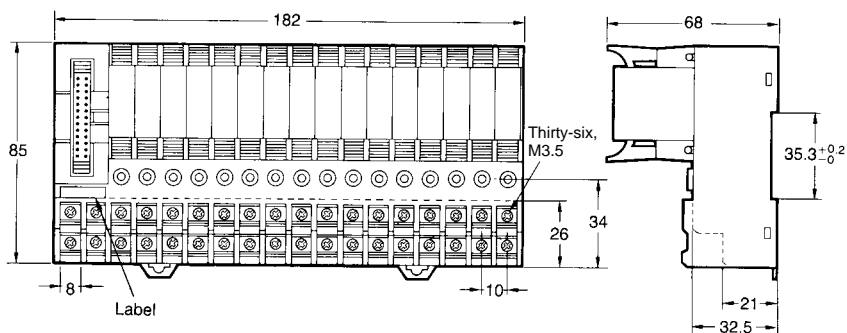
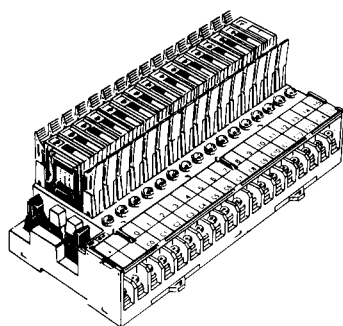

G7TC-OC16
G7TC-OC16-1

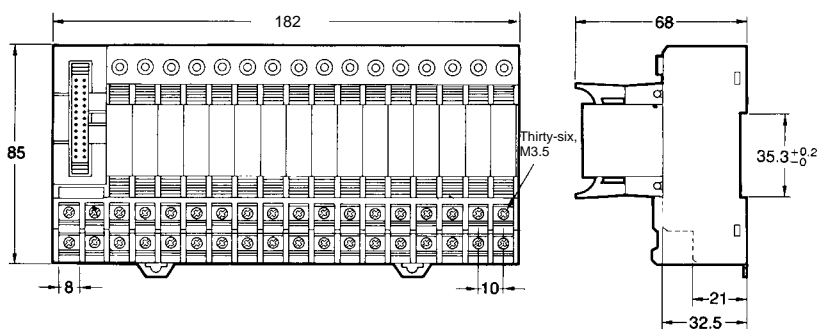
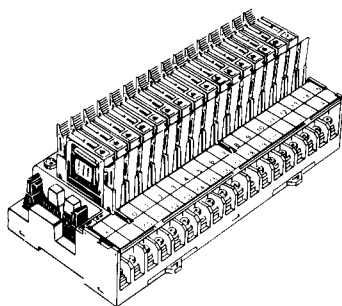

G7TC-OC08

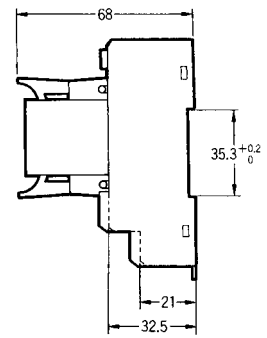
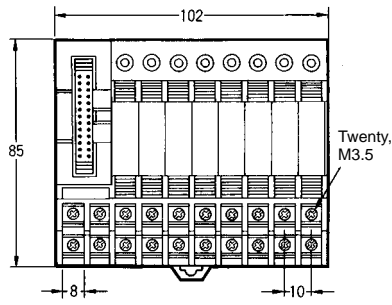
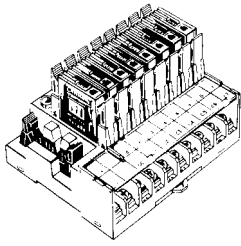

■ Terminal Arrangement/Internal Connection

G7TC-ID16 (NPN input/- common)

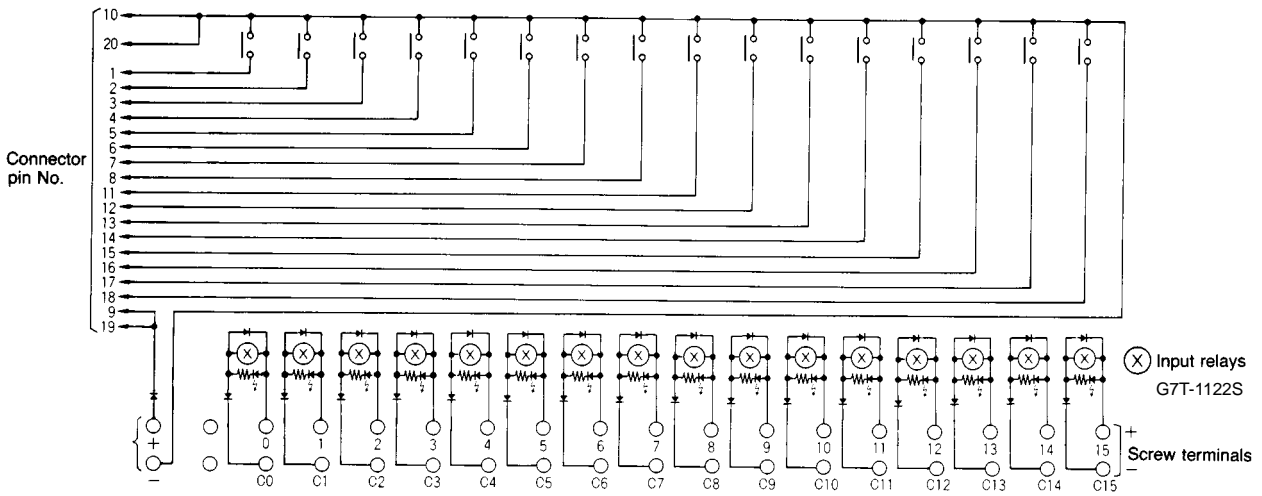

G7TC-IA16 (NPN input/- common)

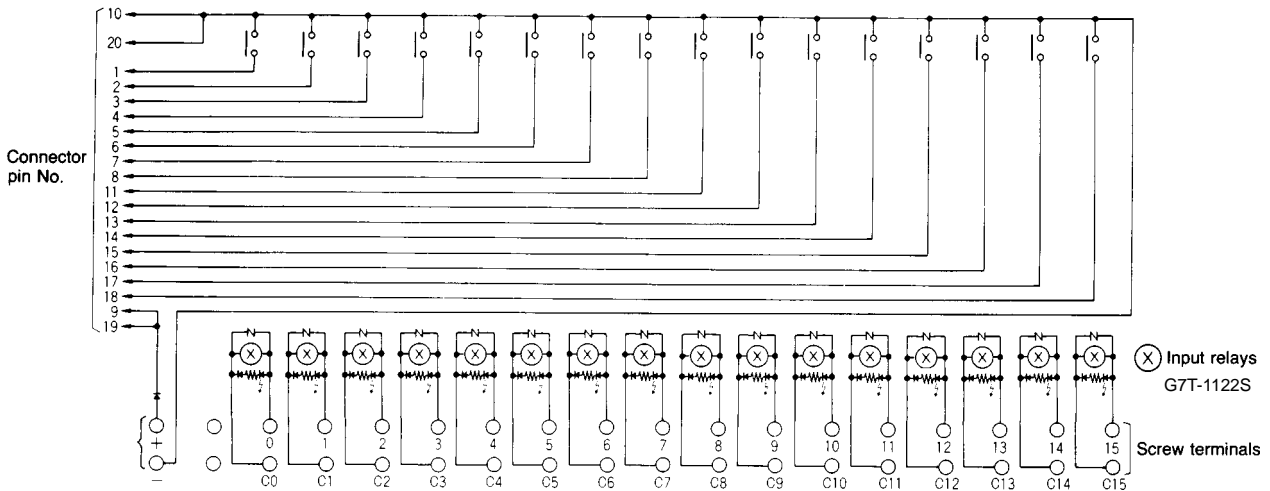

G7TC-OC16

Note: A controller with an NPN transistor, common output can be connected to the G7TC-OC16.

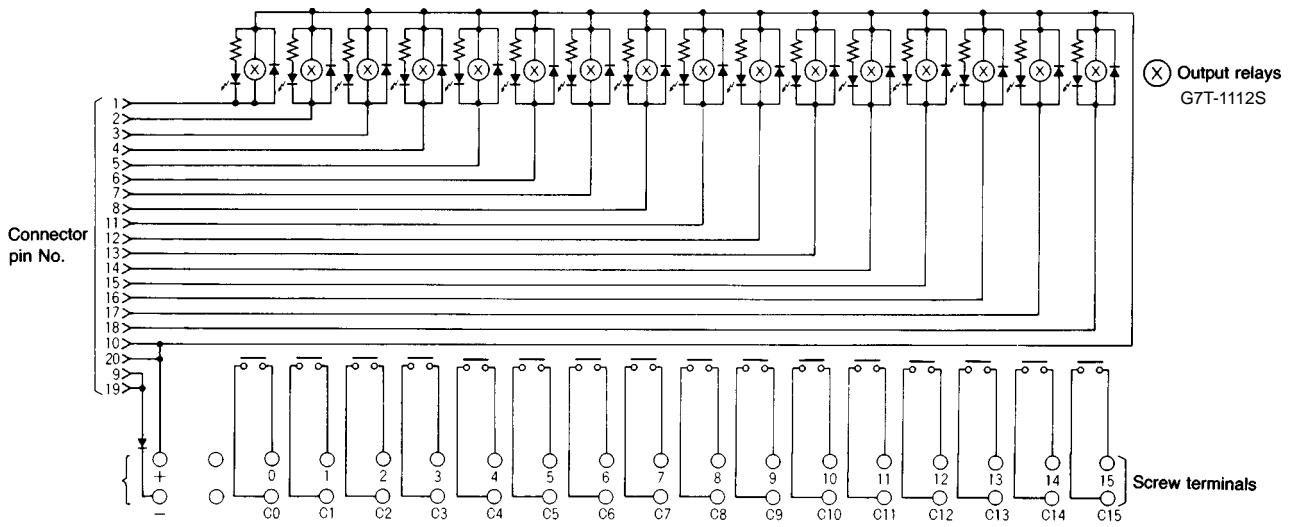

G7TC-OC16-1

Note: A controller with a PNP transistor, + common output can be connected to the G7TC-OC16-1. Do not connect the G71 Remote Interface to the G7TC-OC16-1. Due to the difference in polarity, the G71 will be damaged if the G7TC-OC16-1 and the G71 are connected to each other. Use the G7TC-OC16 (NPN output/+ common) instead, to connect to the G71.

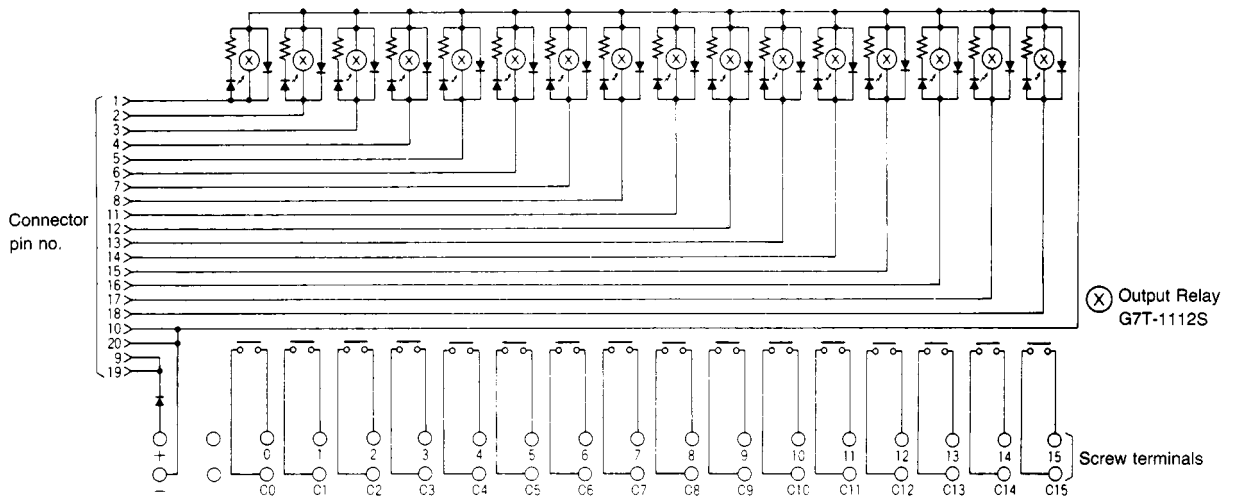

G7TC-OC08 (NPN output/+ common)

Note: A controller with an NPN transistor, – common output can be connected to the G7TC-OC08.

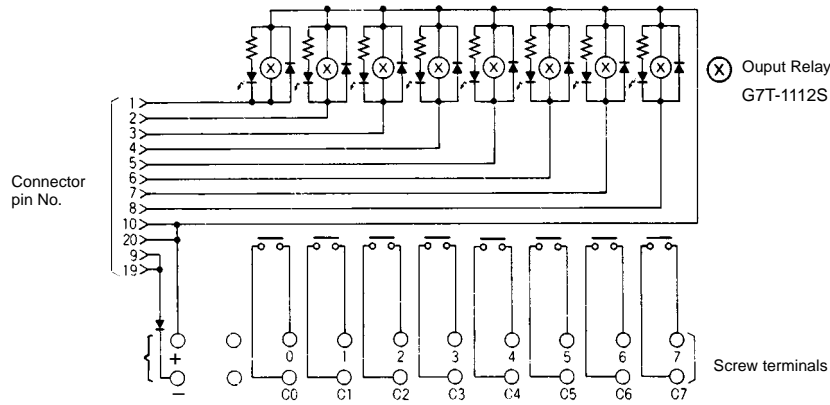

**Connector Pin Configuration
Top View**

I/O indications on Screw Terminals of G7TC-ID16, G7TC-IA16, G7TC-OC16-1

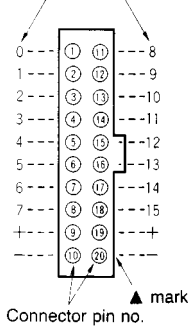

I/O Numbers Allocated to Screw Terminals of G7TC-OC16 and G7TC-OC08

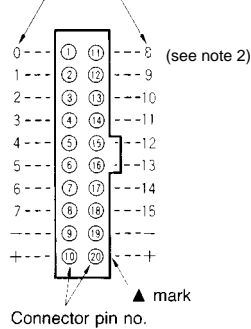

- Note:**
1. Pin numbers are indicated for convenience. The ▲ mark can be used to determine orientation.
 2. The G7TC-OC08 does not have terminals 8 to 15.

Accessories (Order Separately)

■ G79 Connecting Cables

G79-Y□C Connecting Cable with Crimp-type Hooks

This Cable is convenient for connecting I/O Blocks to devices equipped with screw terminals.

Length (ℓ)	Model
1,000 mm	G79-Y100C
1,500 mm	G79-Y150C
2,000 mm	G79-Y200C
3,000 mm	G79-Y300C
5,000 mm	G79-Y500C

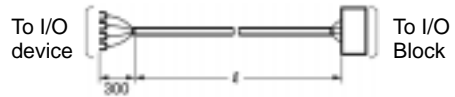

- Note:**
1. Power line capacity must be within 50 mA per I/O point. Always check driver capacity and I/O relay power consumption when using an Output Block.
 2. Hooks are labeled with corresponding connector pin numbers.
 3. Connect terminals 9 and 19 and terminals 10 and 20 together when using the G7TC-OC08.
 4. The separate wires at the device end of the Cable each have a diameter of AWG 28 (10/0.38).

G79-A□C Connecting Cable

This Cable has separate wires at the device end.

Length (ℓ)	Model
2,000 mm	G79-A200C
5,000 mm	G79-A500C



Note: 1. The separate wires at the device end of the Cable each have a diameter of AWG 24 (7/0.203).

2. Connect terminals 9 and 19 and terminals 10 and 20 together when using the G7TC-OC08.

G79-□C Connecting Cable with One Connector

This Cable is convenient for connecting an I/O Block to a single device equipped with one connector socket.

Length (ℓ)	Model
1,000 mm	G79-100C
1,500 mm	G79-150C
2,000 mm	G79-200C
3,000 mm	G79-300C
5,000 mm	G79-500C



G79-O□C-□ and G79-I□C□ Connecting Cables with Two Connectors

Cables for both Output Blocks (for connection to SYSMAC I/O Units; tape color: red) and Input Blocks (for connection to SYSMAC I/O Units; tape color: yellow) are available.

Length		Cables for Input Blocks	Cables for Output Blocks
A	B		
1,000 mm	750 mm	G79-I100C-75	G79-O100C-75
1,500 mm	1,250 mm	G79-I150C-125	G79-O150C-125
2,000 mm	1,750 mm	G79-I200C-175	G79-O200C-175
3,000 mm	2,750 mm	G79-I300C-275	G79-O300C-275
5,000 mm	4,750 mm	G79-I500C-475	G79-O500C-475

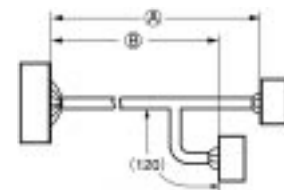

Note: The 32-point card-type connector for Input Block Cables and that for Output Block Cables have different pin arrangements.

G79-□C-□-□ Connecting Cable with Three Connectors

Length			Model
A	B	C	
1,500 mm	1,250 mm	1,000 mm	G79-150C-125-100
2,000 mm	1,750 mm	1,500 mm	G79-200C-175-150
3,000 mm	2,750 mm	2,500 mm	G79-300C-275-250

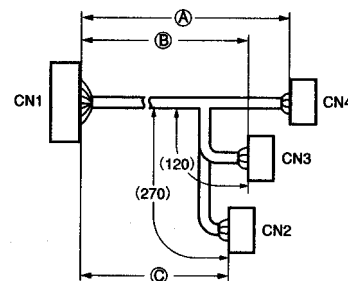

The lengths given are for straight lines and do not take bends into account.

Applicable Sockets

OMRON C200H, C500, C1000H, or C2000H PCs			I/O Block		
I/O Unit	Plug	Socket	Model	Plug	Socket
C200H-ID215 C200H-OD215 C200H-MD215 C500-ID218CN C500-OD415CN	Fujitsu FCN-365P024-AU (two required)	Two of any of the following sets (made by Fujitsu). Set number 1 included. 1. FNC-361J024-AU (solder-type) FNC-360C024-B (connector cover) 2. FNC-363J024-AU (crimp-type) FNC-360C024-B (connector cover) 3. FNC-367J24-AU/F (crimp-type, 1 A max. for common) Set No. 1 is included with the PC. Set No. 3 is included with the G79 cable.	G7TC-IA16 G7TC-ID16 G7TC-OC16	OMRON XG4A-2031 (See note.)	OMRON XG4M-2030 (See note.) XG4T-2004 (See note.) (included with Cable.)

Note: Meets MIL standard

The following OMRON Sockets and Covers can also be used on the G7TC side when manufacturing a connecting cable.

Socket: XG5M-2035 (applicable wire: AWG 26 to AWG 28 (UL-1007))

XG5M-2032 (applicable wire: AWG 24 (UL-1061))

Cover: XG5S-1001 (two required)

XG5S-2012 (one required)

■ Shorting Bar

G78-04

Use this piece for short-circuiting across terminals.

Max. current flow: 20 A

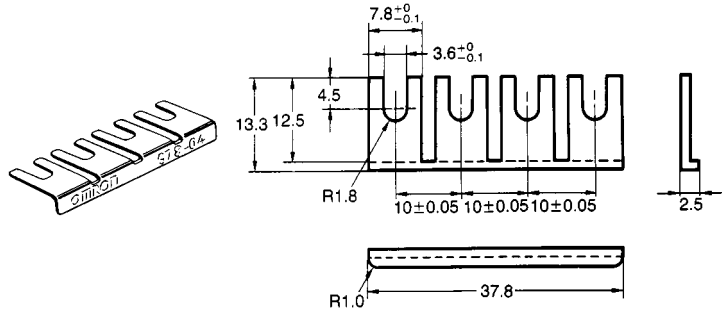

■ Finger Protection Cover for G7TC or P7TF (Meets VDE 0106 Part 100)

G78-E

Note: This cover cannot be used with an 8-point type unit.

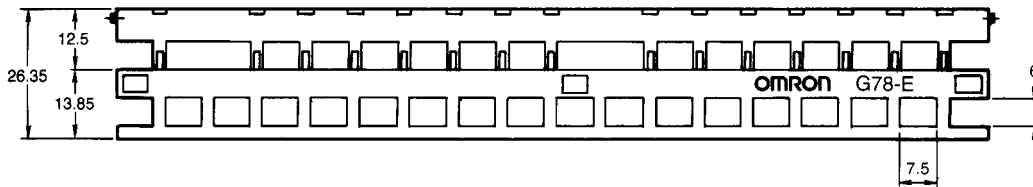
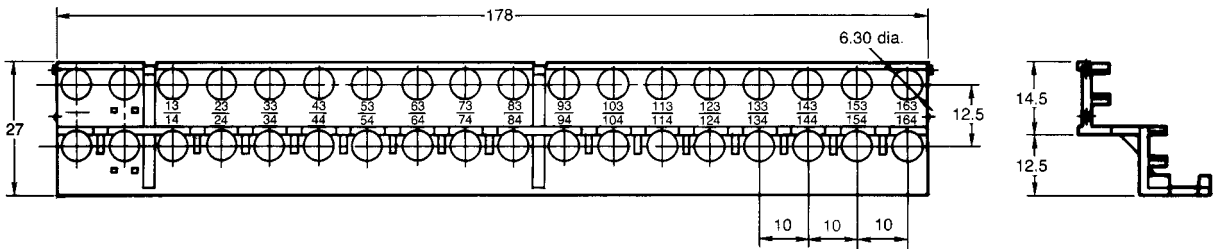

I/O Block Details

Input Blocks

G7TC-ID16
G7TC-IA16

Supply power to terminals 0 through 15 and C0 through C15 according to the voltage specifications of the I/O Relays and I/O Block. Do not reverse positive and negative terminals on the DC Input Block (0 through 15 are positive; C0 through C15, negative). Shorting bars are available.

Supply to the power terminal (positive and negative) the rated voltage of the controller's input circuits (24 VDC or 12 VDC). Use a low-noise power source.

When using a Connecting Cable with two connectors, be sure to use the Cable for Input Blocks. Using the Cable for Output Blocks may result in malfunction or damage to the product.

Connecting Cable: G79-I□C-□
Tape Color: Red

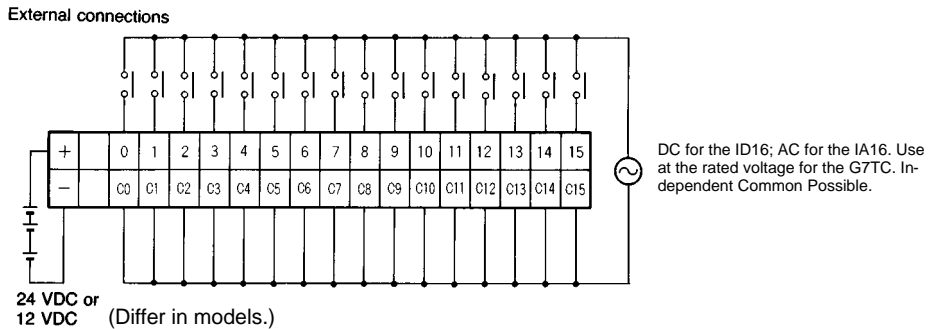
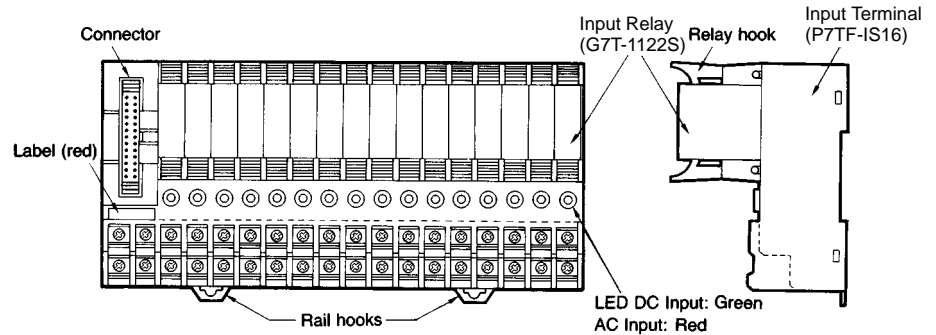

Output Block

G7TC-OC16(-1)
G7TC-OC08

There are voltage specifications for the Relays and Terminals. Depending on the controller connected, select either 12 or 24 VDC.

Supply power to contact output terminals 0 through 15 and C0 through C15 according to the requirements of the loads. A 4 terminal Shorting Bar is available.

Supply to the power terminals (positive and negative) power both for driving the relays and for controller output transistors. Match the controller and I/O block voltage specifications. Use a low-noise power source.

When using a Connecting Cable with two connectors, be sure to use the Cable for Output Blocks. Using the Cable for Input Blocks may result in malfunction or damage to the product.

Connecting Cable: G79-O□C-□
Tape Color: Yellow

Output Block Unit G7TC-OC08 does not have terminals 8 through 15 and C8 through C15. Although a 20-pin connector is used, pins 11 through 18 are not connected.

When an I/O SSR (G3TA-OD□□) is mounted, terminals 0 to 15 will be positive.

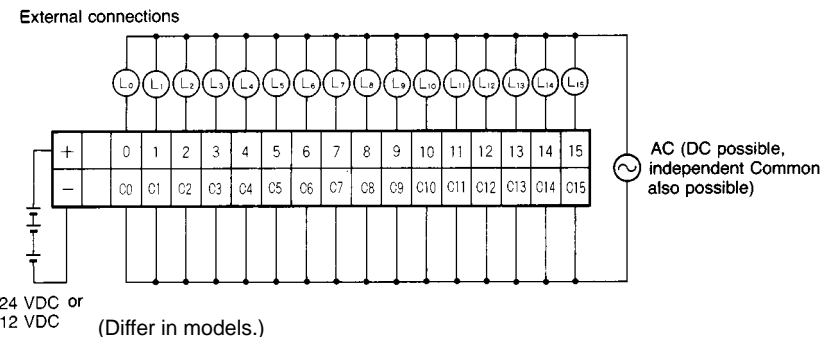
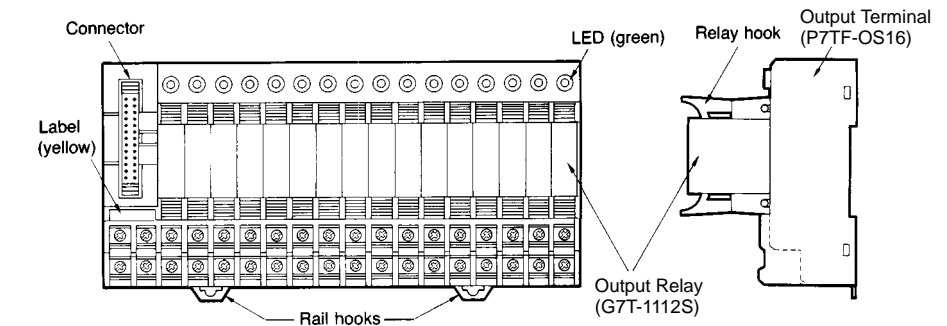

Connection Example for SPDT Relays

The following is an application example for the P7TF-05 using an SPDT Relay on a terminal of the G7TC-16(-1).

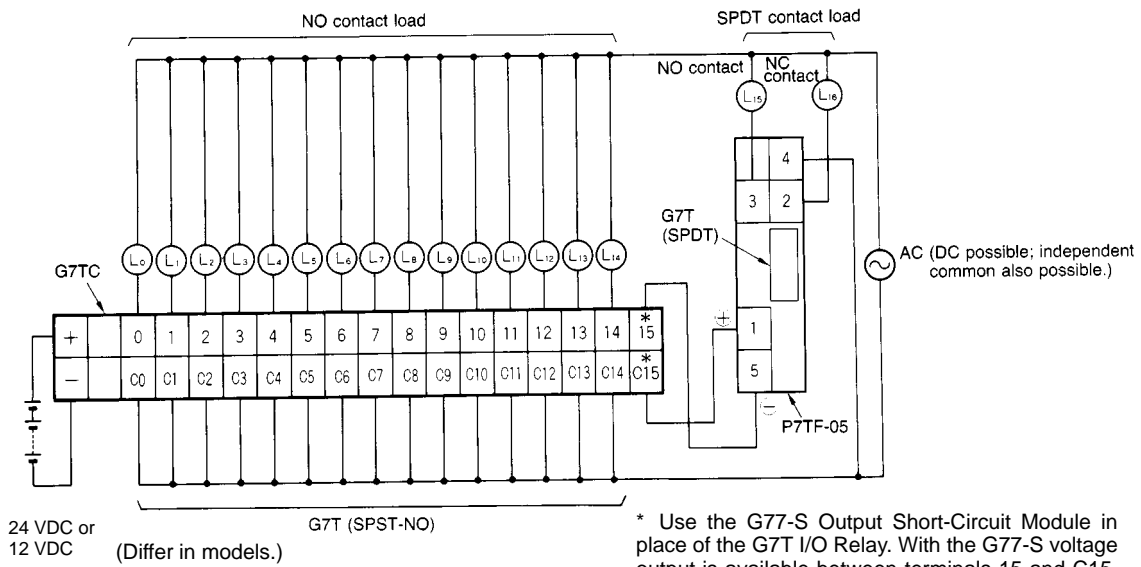

Note: If more than one G77-S Output Short-Circuit Module is employed, the voltage output of the terminals on the G7TC is as follows:
 G7TC-OS16: The positive side (the lower row) connects to the common line internally.
 G7TC-OS16-1: The negative side (the upper row) connects to the common line internally.

■ P7TF-05 Socket

The G7T (SPST-NO, SPST-NC, and SPDT types) and the G3TA I/O Relays can be mounted on the P7TF-05 Socket.

The P7TF-05 can be used for applications involving sequences that require slim relays, or to enable use of SPDT relays with the I/O Block. To use part of the I/O Block with SPDT specifications, insert an Output Short-Circuit Module into the I/O Block, and use the P7TF-05 Socket in combination with an SPDT Relay for the Module's output.

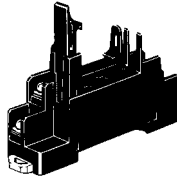

Specifications

Contact resistance	10 mΩ max.
Dielectric strength	2,000 VAC for 1 minute
Insulation resistance	100 MΩ (at 500 V)
Vibration resistance	10 to 55 Hz, 1.0 mm double amplitude
Shock resistance	200 m/s ²
Ambient temperature	Operating: 0 to 55°C
Ambient humidity	35% to 85%
Weight	Approx. 28 g

Dimensions

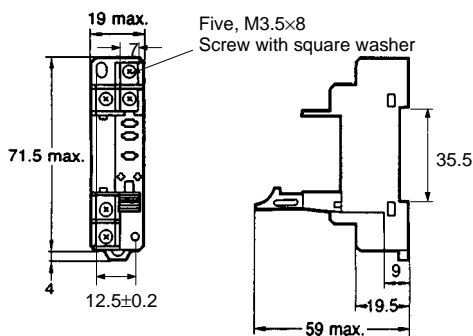

Internal Connections (Top View)

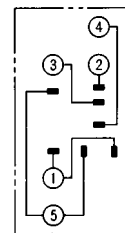

Note: Terminal 1 is positive when the I/O SSR is employed.

Mounting Hole Dimensions

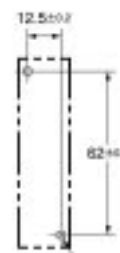

4 dia. or M3

Note: Terminal 1 is positive when the G3TA or Indicator Module is employed.

■ P70 Indicator Module (With Surge Suppressing Function)

Remove the transparent style strip of the P7TF-05 socket and mount this module and it will function as an operation indicator with the surge suppression.

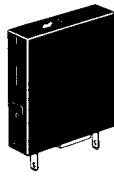

Ordering Information

Model	Applicable relay coil voltage	Remarks
For AC relay	P70A	100 (110) VAC
		200 (220) VAC
For DC relay	P70D	12/24 VDC
		Surge suppressing system with diode

- Note:** 1. Order the indicator module suitable for the relay coil voltage.
 2. The indicator module for DC relays has a multiple power supply common to both 12 and 24 VDC.

Dimensions

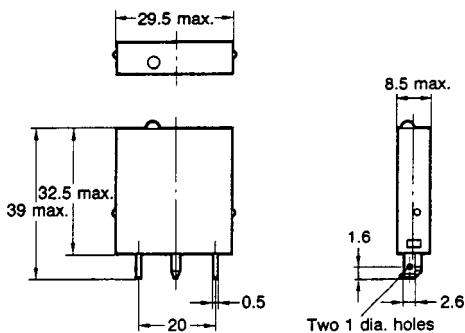

Internal Connection

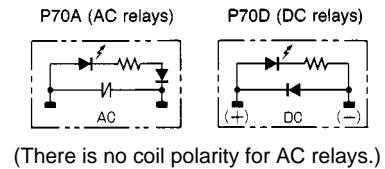

■ G77-S Output Short-Circuit Module

The output of the I/O Block can be obtained without relays through the G77-S Output Short-Circuit Module. Note that the G77-S Output Short-Circuit Module is not available for inputs.

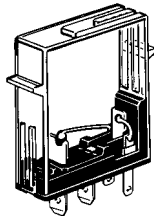

Dimensions

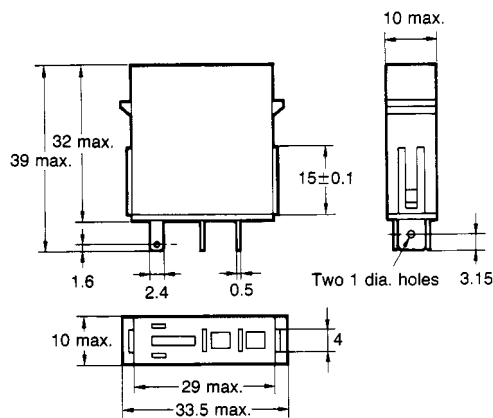

Terminal Arrangement/Internal Connections (Bottom View)

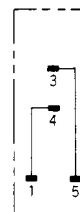

(There is no coil polarity.)

System Configuration

Connector-equipped cables can be used as shown below to quickly connect I/O Blocks to I/O Units.

■ Connecting Cables with Three Connectors

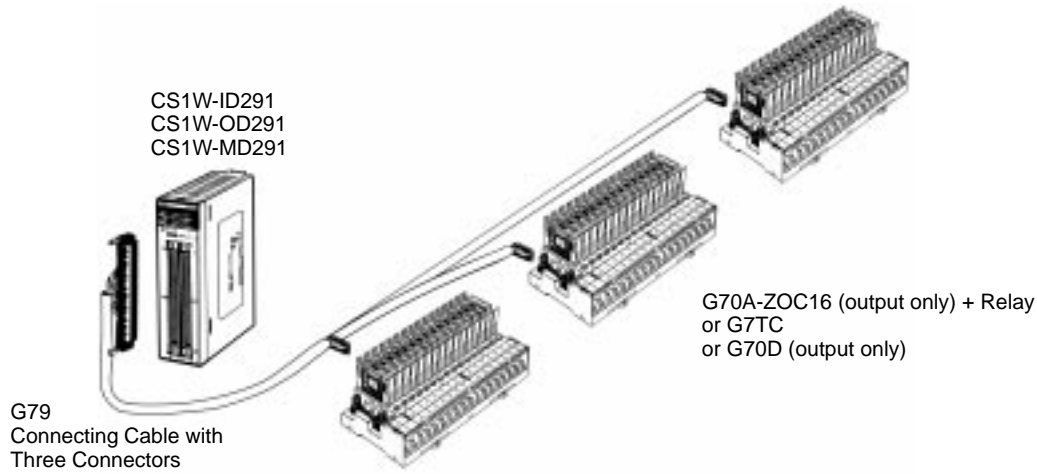

■ Connecting Cables with Two Connectors

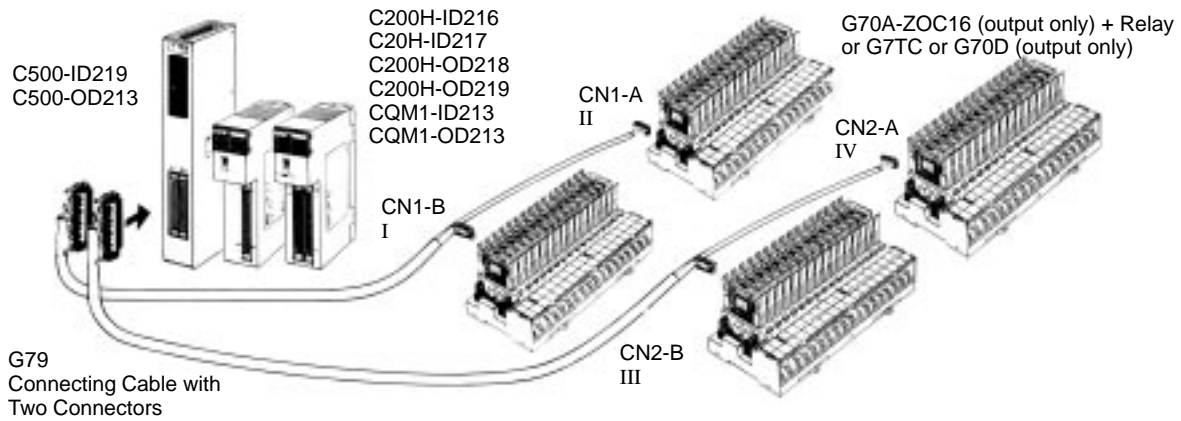

- Note:** 1. In the above diagram, I to IV indicate the column numbers for C500 I/O Unit connector pins.
2. In the above diagram, CN1-A/-B and CN2-A/-B indicate the column numbers for C200H I/O Unit connector pins.

■ Connecting Cables with One Connector

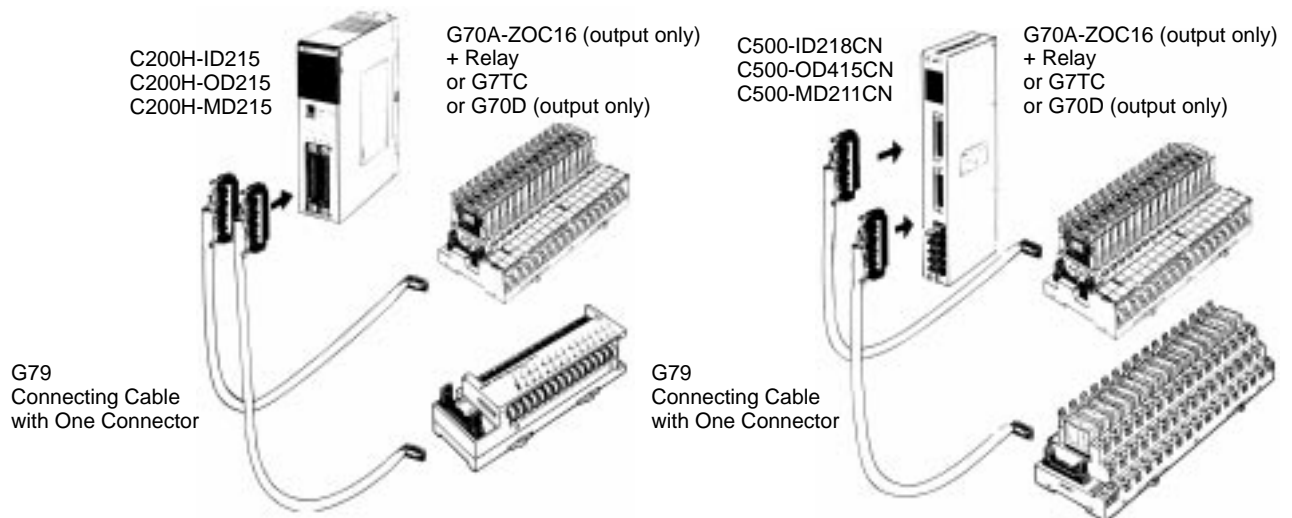

■ Connecting to Programmable Controller through Crimp-type Hooks

I/O Units without connectors can be easily connected to the I/O Block through the connecting cable equipped with crimp-type hooks.

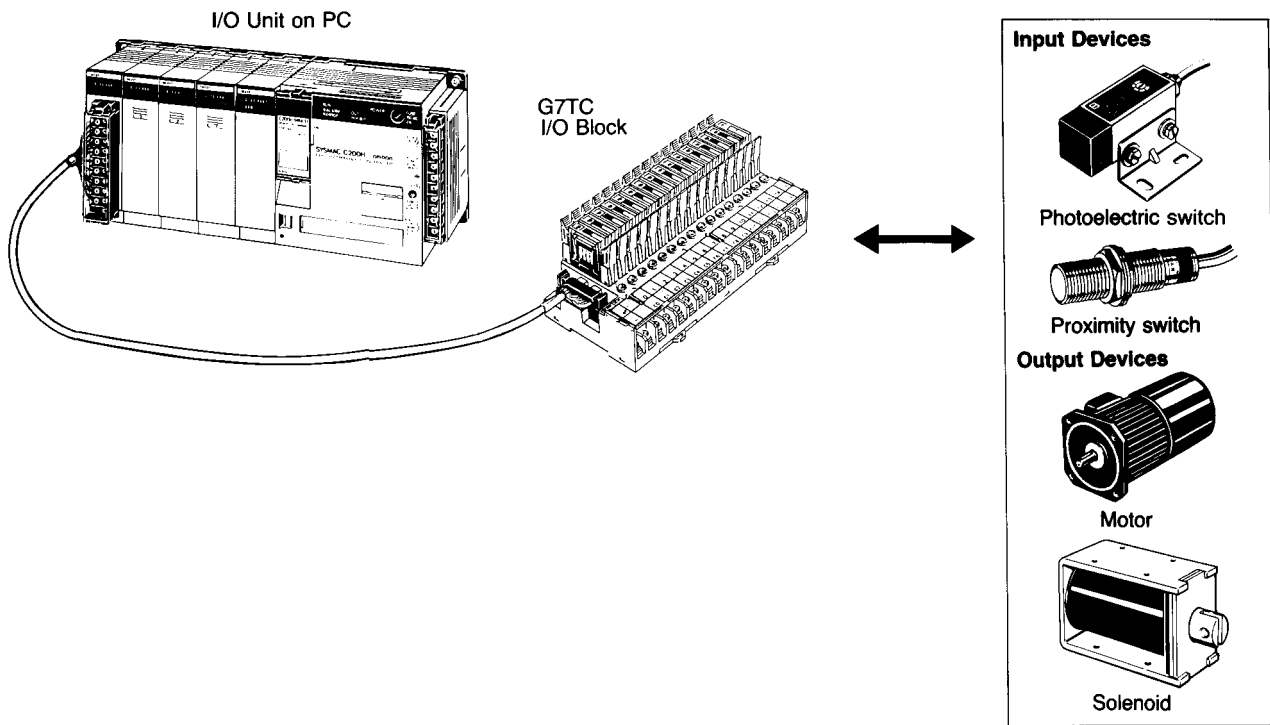

Precautions

■ General

I/O Relays and I/O Block Bases can be combined as follows to form I/O Blocks:

	Combinations (See note.)	Block Base	I/O Relay	I/O SSR	
DC output	G7TC-OC16 G7TC-OC16-1 G7TC-OC08	P7TF-OS16 P7TF-OS16-1 P7TF-OS08	G7T-1112S	AC	G3TA-OA202SZ G3TA-OA202SL
				DC	G3TA-ODX02S G3TA-OD201S
DC input	G7TC-ID16	P7TF-IS16 (DC type)	G7T-1122S	AC	G3TA-IDZ002 (M)
AC input	G7TC-IA16	P7TF-IS16 (AC type)		DC	G3TA-IAZR02S

Note: The model numbers given under "Combinations" are for combinations with I/O Relays. To use I/O SSRs, either replace an I/O Relay with the SSR, or purchase an I/O Terminal (Block Base) and an I/O SSR (i.e., not the combined Unit).

- Combinations of AC Input Relays/SSRs and DC Input Relays/SSRs cannot be used with the same Terminal. This is because specifications for coil surge suppression elements are different.
Relays/SSRs with different voltage specifications cannot be used with the same Terminal. (For example, a 100-VAC Input Relay and a 200-VAC Input Relay, or a 12-VDC Output Relay and a 24-VDC Output Relay cannot be used with the same Terminal.) This is because specifications of operation indicator circuits are different.
- Only use I/O Terminals, I/O Relays, and I/O SSRs with the same specifications for rated voltage.

■ General

- I/O Blocks are color coded, as shown below, according to input/output and AC/DC specifications.

	I/O Terminal label	I/O Terminal indicators	I/O Relay case
Output Block (DC)	Yellow	Green	Transparent
Input Block	DC	Green	Green
	AC	Red	Red

- Both Input and Output Blocks do not have internal power supplies. For an Output Block, supply the relay drive power to the positive and negative terminals (either 12 or 24 VDC). Loads (terminal contacts 0 through 15) must also be supplied with appropriate power. For an Input Block, supply, to the positive and negative terminals, power for input signals to the controller.
- The same Connecting Cable, G79-Y, is used for the G7TC-OC08 eight-point Output Block as for other I/O Blocks; leave 8 points unconnected.
- Indicators indicate the presence or absence of signals.
Use the display lever inside each relay for fault diagnosis. (Some relays do not have this lever depending on the specifications.)
- Each relay must be pressed down until its hold-down hooks engage completely. Heating or malfunction can result if relays are not mounted properly.
- Unlabeled terminals are not electrically connected. Use these for repeater terminals.
- Indicator positions and relay orientation differ between Input and Output Blocks. This is to aid in differentiating Input Blocks from Output Blocks and in following signal flow.
- DC Input Blocks and Output Blocks with G3TA-OD□□□□ have positive and negative terminals, with the positive terminals normally being on the top of the I/O Block. Reversing positive and negative terminals will prevent operation.

- DIN tracks are generally used to mount I/O Blocks. For screw mounting, a 210-mm DIN track is available that can be used as an adapter in combination with End Plates (PFP-M, two required).
- A Shorting Bar is provided to connect four terminals. The current capacity of the shorting bar is 20 A. As long as this current capacity is not exceeded, the shorting bar can be used in combination as shown at the right to connect more than four terminals.

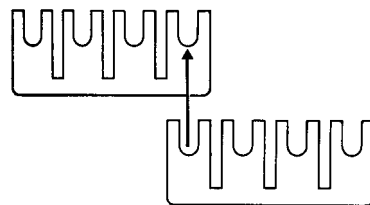

- Special Connecting Cables are provided for connections to OMRON SYSMAC I/O Units with Connectors. Connecting Cables with two connectors, however, come in two types: Cables for Input Blocks (G79-I) and Cables for Output Blocks (G79-O). Be sure to purchase the correct Cable for the application.

■ Microload Switching

Input Relays (DC coil type) and I/O SSRs (DC input type) can be mounted onto an Output Block. Doing so enables using controller programming to simultaneously switch on or off two outputs (DPST-NO operation) to switch a SPST-NO load that in turn switches another SPST-NO load. One configuration for this is shown below.

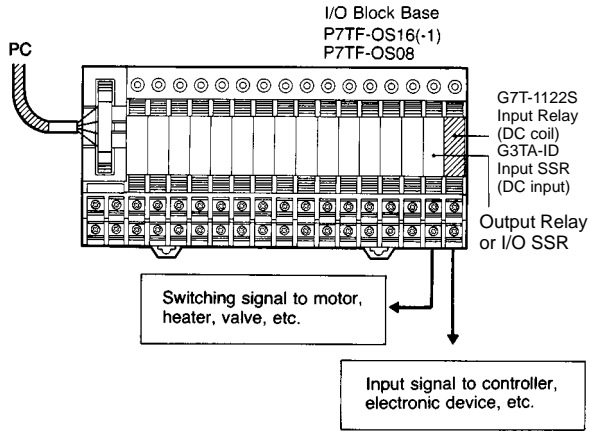

ALL DIMENSIONS SHOWN ARE IN MILLIMETERS.

To convert millimeters into inches, multiply by 0.03937. To convert grams into ounces, multiply by 0.03527.

Cat. No. J104-E1-2 **In the interest of product improvement, specifications are subject to change without notice.**

OMRON Corporation

Industrial Automation Company

Industrial Devices and Components Division H.Q.
New Business Group
Shiokoji Horikawa, Shimogyo-ku,
Kyoto, 600-8530 Japan
Tel: (81)75-344-7116/Fax: (81)75-344-7189

Printed in Japan
0101-1M (0796) (A)

Read and Understand This Catalog

Please read and understand this catalog before purchasing the products. Please consult your OMRON representative if you have any questions or comments.

Warranty and Limitations of Liability

WARRANTY

OMRON's exclusive warranty is that the products are free from defects in materials and workmanship for a period of one year (or other period if specified) from date of sale by OMRON.

OMRON MAKES NO WARRANTY OR REPRESENTATION, EXPRESS OR IMPLIED, REGARDING NON-INFRINGEMENT, MERCHANTABILITY, OR FITNESS FOR PARTICULAR PURPOSE OF THE PRODUCTS. ANY BUYER OR USER ACKNOWLEDGES THAT THE BUYER OR USER ALONE HAS DETERMINED THAT THE PRODUCTS WILL SUITABLY MEET THE REQUIREMENTS OF THEIR INTENDED USE. OMRON DISCLAIMS ALL OTHER WARRANTIES, EXPRESS OR IMPLIED.

LIMITATIONS OF LIABILITY

OMRON SHALL NOT BE RESPONSIBLE FOR SPECIAL, INDIRECT, OR CONSEQUENTIAL DAMAGES, LOSS OF PROFITS, OR COMMERCIAL LOSS IN ANY WAY CONNECTED WITH THE PRODUCTS, WHETHER SUCH CLAIM IS BASED ON CONTRACT, WARRANTY, NEGLIGENCE, OR STRICT LIABILITY.

In no event shall responsibility of OMRON for any act exceed the individual price of the product on which liability is asserted.

IN NO EVENT SHALL OMRON BE RESPONSIBLE FOR WARRANTY, REPAIR, OR OTHER CLAIMS REGARDING THE PRODUCTS UNLESS OMRON'S ANALYSIS CONFIRMS THAT THE PRODUCTS WERE PROPERLY HANDLED, STORED, INSTALLED, AND MAINTAINED AND NOT SUBJECT TO CONTAMINATION, ABUSE, MISUSE, OR INAPPROPRIATE MODIFICATION OR REPAIR.

Application Considerations

SUITABILITY FOR USE

OMRON shall not be responsible for conformity with any standards, codes, or regulations that apply to the combination of products in the customer's application or use of the product.

At the customer's request, OMRON will provide applicable third party certification documents identifying ratings and limitations of use that apply to the products. This information by itself is not sufficient for a complete determination of the suitability of the products in combination with the end product, machine, system, or other application or use.

The following are some examples of applications for which particular attention must be given. This is not intended to be an exhaustive list of all possible uses of the products, nor is it intended to imply that the uses listed may be suitable for the products:

- Outdoor use, uses involving potential chemical contamination or electrical interference, or conditions or uses not described in this catalog.
- Nuclear energy control systems, combustion systems, railroad systems, aviation systems, medical equipment, amusement machines, vehicles, safety equipment, and installations subject to separate industry or government regulations.
- Systems, machines, and equipment that could present a risk to life or property.

Please know and observe all prohibitions of use applicable to the products.

NEVER USE THE PRODUCTS FOR AN APPLICATION INVOLVING SERIOUS RISK TO LIFE OR PROPERTY WITHOUT ENSURING THAT THE SYSTEM AS A WHOLE HAS BEEN DESIGNED TO ADDRESS THE RISKS, AND THAT THE OMRON PRODUCT IS PROPERLY RATED AND INSTALLED FOR THE INTENDED USE WITHIN THE OVERALL EQUIPMENT OR SYSTEM.

Disclaimers

CHANGE IN SPECIFICATIONS

Product specifications and accessories may be changed at any time based on improvements and other reasons.

It is our practice to change model numbers when published ratings or features are changed, or when significant construction changes are made. However, some specifications of the product may be changed without any notice. When in doubt, special model numbers may be assigned to fix or establish key specifications for your application on your request. Please consult with your OMRON representative at any time to confirm actual specifications of purchased product.

DIMENSIONS AND WEIGHTS

Dimensions and weights are nominal and are not to be used for manufacturing purposes, even when tolerances are shown.

ERRORS AND OMISSIONS

The information in this catalog has been carefully checked and is believed to be accurate; however, no responsibility is assumed for clerical, typographical, or proofreading errors, or omissions.

PERFORMANCE DATA

Performance data given in this catalog is provided as a guide for the user in determining suitability and does not constitute a warranty. It may represent the result of OMRON's test conditions, and the users must correlate it to actual application requirements. Actual performance is subject to the OMRON Warranty and Limitations of Liability.

PROGRAMMABLE PRODUCTS

OMRON shall not be responsible for the user's programming of a programmable product, or any consequence thereof.

COPYRIGHT AND COPY PERMISSION

This catalog shall not be copied for sales or promotions without permission.

This catalog is protected by copyright and is intended solely for use in conjunction with the product. Please notify us before copying or reproducing this catalog in any manner, for any other purpose. If copying or transmitting this catalog to another, please copy or transmit it in its entirety.

Mouser Electronics

Authorized Distributor

Click to View Pricing, Inventory, Delivery & Lifecycle Information:

[Omron:](#)

[G78-E](#)

Компания «Life Electronics» занимается поставками электронных компонентов импортного и отечественного производства от производителей и со складов крупных дистрибьюторов Европы, Америки и Азии.

С конца 2013 года компания активно расширяет линейку поставок компонентов по направлению коаксиальный кабель, кварцевые генераторы и конденсаторы (керамические, пленочные, электролитические), за счёт заключения дистрибьюторских договоров

Мы предлагаем:

- Конкурентоспособные цены и скидки постоянным клиентам.
- Специальные условия для постоянных клиентов.
- Подбор аналогов.
- Поставку компонентов в любых объемах, удовлетворяющих вашим потребностям.
- Приемлемые сроки поставки, возможна ускоренная поставка.
- Доставку товара в любую точку России и стран СНГ.
- Комплексную поставку.
- Работу по проектам и поставку образцов.
- Формирование склада под заказчика.
- Сертификаты соответствия на поставляемую продукцию (по желанию клиента).
- Тестирование поставляемой продукции.
- Поставку компонентов, требующих военную и космическую приемку.
- Входной контроль качества.
- Наличие сертификата ISO.

В составе нашей компании организован Конструкторский отдел, призванный помогать разработчикам, и инженерам.

Конструкторский отдел помогает осуществить:

- Регистрацию проекта у производителя компонентов.
- Техническую поддержку проекта.
- Защиту от снятия компонента с производства.
- Оценку стоимости проекта по компонентам.
- Изготовление тестовой платы монтаж и пусконаладочные работы.



Тел: +7 (812) 336 43 04 (многоканальный)

Email: org@lifeelectronics.ru