

Helping Customers Innovate, Improve & Grow



OX-046

### Features

- Ultra Low G-Sensitivity
- Low Phase Noise
- Very High Frequency
- Frequency Range: 50 MHz to 250 MHz
- Standard Frequency: 100 MHz
- Vibration Compensation

### Applications

- Military Avionics
- Airborne Radar
- Test Equipment
- Frequency Synthesizers
- Position Location
- Satellite Communications

### Performance Specifications

Parameter	Min	Typ	Max	Units	Condition
Available Frequencies					
Frequency Range	50		250	MHz	
G-Sensitivity Performance					
standard crystal			1.5	ppb/g	
g-Sensitivity w\ Low g-Crystal			0.5	ppb/g	
g-Sensitivity w\ Low g-Crystal & Vibration compensation			0.05	ppb/g	Degrades to 0.5 ppb/g above 250 Hz
(No mechanical resonances out to 2KHz)					G sensitivity specified per axis
For oscillators with 0.2 ppb/g out to 2 KHz please contact factory.					
Frequency Stabilities <sup>1</sup>					
(Stabilities listed for 100 MHz. For Stabilities above 100 MHz values may degrade. Please contact factory.)					
vs. Operating Temperature Range (referenced to +25°C)	-200 -150 -100 -50		+200 +150 +100 +50	ppb ppb ppb ppb	-40... +85°C -40... +70°C -20... +70°C 0... +70°C
Initial Tolerance	-500		+500	ppb	at time of shipment, nominal EFC
vs. Supply Voltage Change	-10		+10	ppb	Vs ± 5%
vs. Load Change	-10		+10	ppb	Load ± 5%
vs. Aging / Daily	-5		+5	ppb	after 30 days operation
vs. Aging / 1 <sup>st</sup> Year	-200		+200	ppb	after 30 days operation
vs. Aging / 10 Year	-1.5		+1.5	ppm	after 30 days operation
Retrace <sup>2</sup>	-200		+200	ppb	
Warm-up Time			5	minutes	to ± 100ppb of final frequency (2 hour reading) @ +25°C

## Performance Specifications

Parameter	Min	Typ	Max	Units	Condition
<b>Supply Voltage (Vs)</b>					
Supply voltage	14.25	15.0	15.75	VDC	ordering code A
	11.4	12.0	12.6	VDC	ordering code B
Oven Power Consumption			10.0	Watts	during warm-up all temperatures
			3.8	Watts	steady state @ +25°C
			7.0	Watts	steady state @ -40°C
			1.0	Watts	steady state @ +85°C
<b>RF Output</b>					
Start Time		1	2	s	time required to achieve 90% of amplitude
Signal	Sinewave				
Load		50		Ohm	
Output Power	+7.0	+10	+13	dBm	
Harmonics			-30	dBc	
Subharmonics			-30	dBc	for oscillator with output frequency > 120 MHz
<b>Frequency Tuning (EFC)</b>					
Tuning Range	±2.0		±3.0	ppm	Electronic frequency control
Linearity			20	%	
Tuning Slope	Positive				
Control Voltage Range	0.0	+5.0	+10.0	VDC	
Input Resistance	15			kOhm	
Modulation Bandwidth	150			Hz	
<b>Phase Noise</b>					
Phase Noise <sup>3</sup> (@ 100 MHz) (under static conditions - no vibration)			-100	dBc/Hz	10 Hz
			-130	dBc/Hz	100 Hz
			-150	dBc/Hz	1 KHz
			-165	dBc/Hz	10 KHz
			-175	dBc/Hz	100 KHz
Phase Noise <sup>3</sup> (@ 200 MHz) (under static conditions - no vibration)			-90	dBc/Hz	10 Hz
			-120	dBc/Hz	100 Hz
			-140	dBc/Hz	1 KHz
			-155	dBc/Hz	10 KHz
			-165	dBc/Hz	100 KHz

Parameter	Min	Typ	Max	Units	Condition
<b>Additional Parameters<sup>1</sup></b>					
Weight			150	g	
<b>Absolute Maximum Ratings</b>					
Supply voltage (Vs)			28	V	
Output Load	25		open	ohm	
Operable Temperature Range	-55		+85	°C	
<b>Environmental Specifications</b>					
Shock (Operating)	MIL-STD-202, Method 213, Condition J, 30G, 11ms, half sine				
Shock (Endurance)	Mil-STD-202, Method 213, Condition C, 100G, 6ms, half sine				
Sine Vibration (Operating)	Mil-STD-202, Method 204, Condition C, 10 G				
Sine Vibration (Endurance)	Mil-STD-202, Method 204, Condition D, 20 G				
Random Vibration (Operating)	Mil-STD-202, Method 214, Condition I-C, 9.26 Grms, 3-5min/axis (without vibe comp) Mil-STD-202, Method 214, Condition I-A, 5.35 Grms, 3-5min/axis (with vibe comp)				
Random Vibration (Endurance)	Mil-STD-202, Method 214, Condition I-D, 11.95 Grms, 3hrs/axis				
Seal	Nonhermetic - Mil-STD-202, Method 112, Condition D available only as custom part number - please contact factory				
Humidity	MIL-STD-202, Method 103, Condition B, 90% rh				
Altitude	MIL-STD-202, Method 105, sea level to 30,000 ft				
Resistance to Soldering Heat	MIL-STD-202, Method 210, Condition A,B,C				
RoHS	not RoHS compliant				
Terminal Strength	MIL-STD-202, Method 211, Condition C (5 bends at 45°, 2 lbs)				
Moisture Sensitivity Level	1				
Storage Temperature Range	-55		+125	°C	

# Outline Drawing / Enclosure

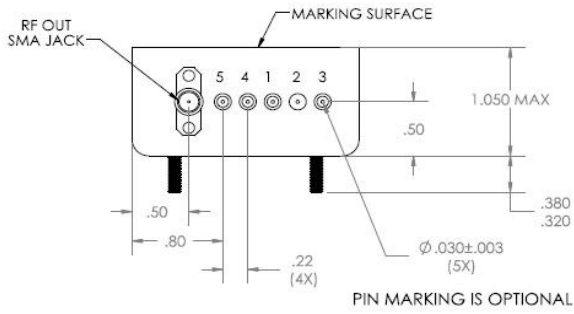

Dimensions in inches

Package configuration A		
ordering code	Height "H"	
5	0.80	
0	1.05	

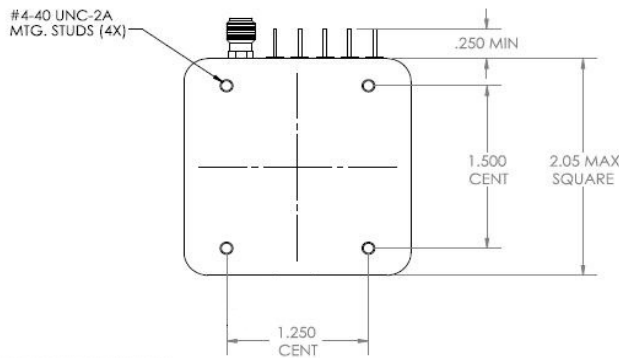

Pin Connections	
1	Electronic Frequency Control (EFC)
2	Ground (Case)
3	Supply Voltage
4	Microsemi Internal Use Only / NC
5	Microsemi Internal Use Only / NC

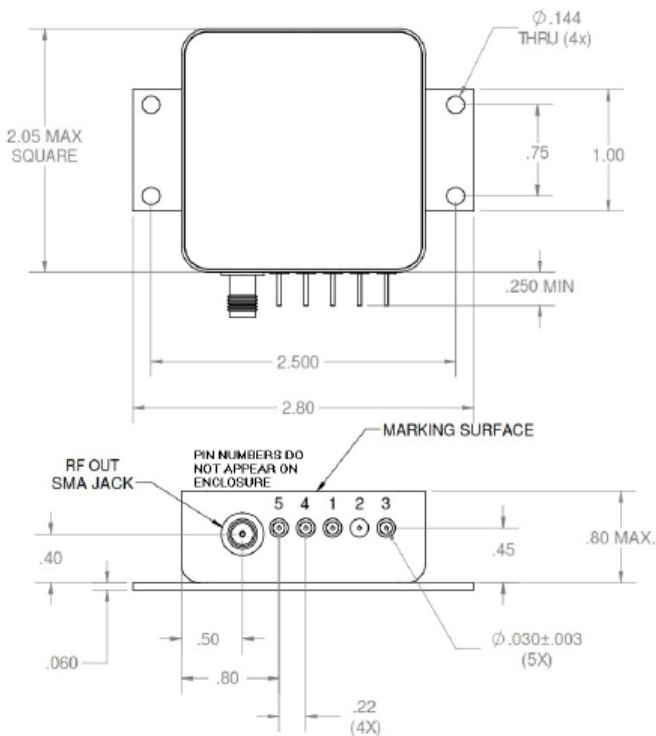

Package configuration C		
ordering code	Height "H"	
7	0.80	
2	1.05	

Pin Connections	
1	Electronic Frequency Control (EFC)
2	Ground (Case)
3	Supply Voltage
4	Microsemi Internal Use Only / NC
5	Microsemi Internal Use Only / NC

## Ordering Information<sup>4</sup>

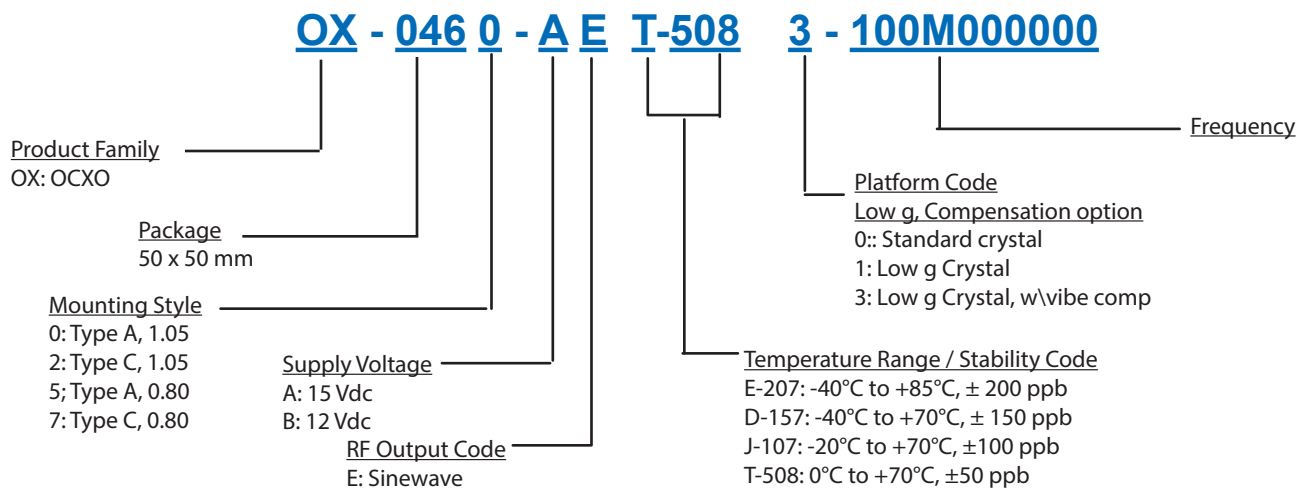

## Additional Ordering Options

Additional ordering options available include custom temperature ranges, custom temperature stabilities, custom phase noise requirements, low profile, custom supply voltage, hermetic option and improved g-sensitivity. These modifications require a custom dash number - please contact the factory for additional information.

### Notes:

1. Unless otherwise stated, all values are valid after warm-up time and refer to typical conditions for supply voltage, frequency control voltage, load, and temperature (25°C).
2. Retrace is defined as the frequency difference between the end of two 24 hour on power periods with a 24 hour off period in between while at a constant temperature.
3. Phase noise degrades with increasing output frequency.
4. Not all options and codes available at all frequencies.

## Contact Information

### USA:

100 Watts Street  
Mt Holly Springs, PA 17065  
Tel: 1.717.486.3411  
Fax: 1.717.486.5920

### Europe:

Landstrasse  
74924 Neckarbischofsheim  
Germany  
Tel: +49 (0) 7268.801.0  
Fax: +49 (0) 7268.801.281



Information contained in this publication regarding device applications and the like is provided only for your convenience and may be superseded by updates. It is your responsibility to ensure that your application meets with your specifications. MICROCHIP MAKES NO REPRESENTATION OR WARRANTIES OF ANY KIND WHETHER EXPRESS OR IMPLIED, WRITTEN OR ORAL, STATUTORY OR OTHERWISE, RELATED TO THE INFORMATION INCLUDING, BUT NOT LIMITED TO ITS CONDITION, QUALITY, PERFORMANCE, MERCHANTABILITY OR FITNESS FOR PURPOSE. Microchip disclaims all liability arising from this information and its use. Use of Microchip devices in life support and/or safety applications is entirely at the buyer's risk, and the buyer agrees to defend, indemnify and hold harmless Microchip from any and all damages, claims, suits, or expenses resulting from such use. No licenses are conveyed, implicitly, or otherwise, under any Microchip intellectual property rights unless otherwise stated.

### Trademarks

The Microchip and Vectron names and logos are registered trademarks of Microchip Technology Incorporated in the U.S.A. and other countries.

Компания «Life Electronics» занимается поставками электронных компонентов импортного и отечественного производства от производителей и со складов крупных дистрибьюторов Европы, Америки и Азии.

С конца 2013 года компания активно расширяет линейку поставок компонентов по направлению коаксиальный кабель, кварцевые генераторы и конденсаторы (керамические, пленочные, электролитические), за счёт заключения дистрибьюторских договоров

Мы предлагаем:

- Конкурентоспособные цены и скидки постоянным клиентам.
- Специальные условия для постоянных клиентов.
- Подбор аналогов.
- Поставку компонентов в любых объемах, удовлетворяющих вашим потребностям.
- Приемлемые сроки поставки, возможна ускоренная поставка.
- Доставку товара в любую точку России и стран СНГ.
- Комплексную поставку.
- Работу по проектам и поставку образцов.
- Формирование склада под заказчика.
- Сертификаты соответствия на поставляемую продукцию (по желанию клиента).
- Тестирование поставляемой продукции.
- Поставку компонентов, требующих военную и космическую приемку.
- Входной контроль качества.
- Наличие сертификата ISO.

В составе нашей компании организован Конструкторский отдел, призванный помогать разработчикам, и инженерам.

Конструкторский отдел помогает осуществить:

- Регистрацию проекта у производителя компонентов.
- Техническую поддержку проекта.
- Защиту от снятия компонента с производства.
- Оценку стоимости проекта по компонентам.
- Изготовление тестовой платы монтаж и пусконаладочные работы.



Тел: +7 (812) 336 43 04 (многоканальный)

Email: [org@lifeelectronics.ru](mailto:org@lifeelectronics.ru)