

4-wire Resistive Touch Screen Controller

BU21025GUL



General Description

BU21025GUL is a low power 4-wire resistive touch screen controller. BU21025GUL measures coordinates and touch pressures with a 12bit A/D converter. BU21025GUL has a digital filter for noise reduction.

Features

- 4-wire resistive touch screen controller
- Single 1.65V to 3.60V supply.
- Low standby current (0.8uA max)
- 12bit SAR A/D converter
- 2-wire serial interface
- Command base interface
- Digital filter
- Touch pressure measurement
- Auto power down control
- Built-in clock oscillation circuit

Key Specifications

- Power supply voltage 1.65V to 3.60V
- Temperature range -30°C to 85°C
- Standby current 0.8uA (Max.)
- Operating current 120uA (Typ.)
- Coordinate resolution 12Bits

Package

VCSP50L2 W (Typ.) x D (Typ.) x H (Max.)
2.00 mm x 1.50 mm x 0.55mm

Applications

- Equipment with a built in user interface of 4-wire resistive touch screen
- Portable device such as smart phone, tablet, PDA.
- Digital still camera, digital video camera, portable TV.
- PC / PC peripheral equipment such as laptop PC, touch screen monitor, printer.

Typical Application Circuit

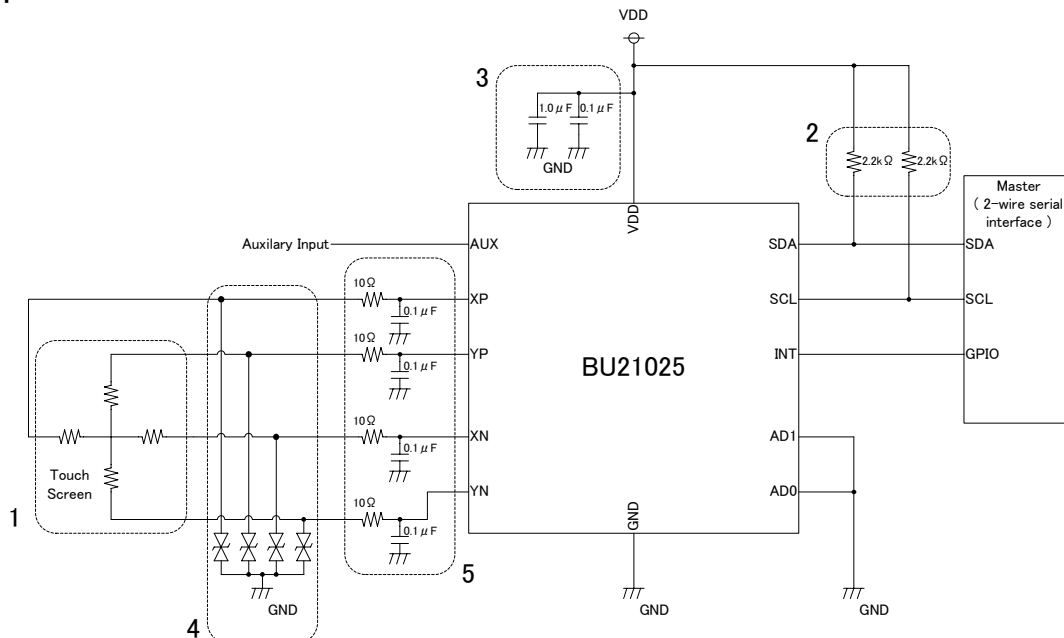

1. 4-wire resistive touch screen
2. Pull-up resistor for 2-wire serial interface
3. Bypass capacitors
4. Diodes for EDS protection
5. Low pass filter for noise reduction

●Pin Configurations

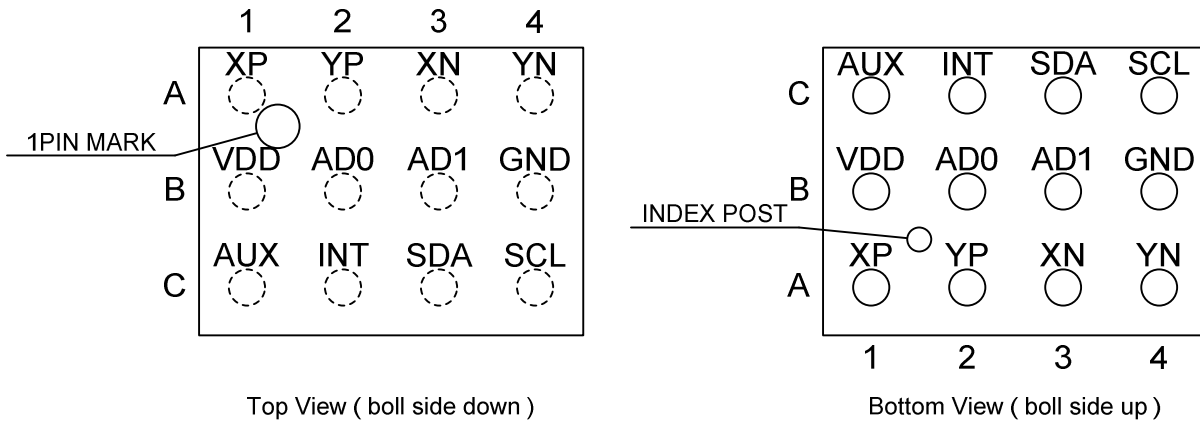

●Pin Descriptions

PIN NO.	NAME	I/O	DESCRIPTION
A1	XP	I/O	Screen interface
A2	YP	I/O	Screen interface
A3	XN	I/O	Screen interface
A4	YN	I/O	Screen interface
B1	VDD	-	Power supply
B2	AD0	I	Slave address bit0 input
B3	AD1	I	Slave address bit1 input
B4	GND	-	Ground
C1	AUX	I	Auxiliary input
C2	INT	O	Interrupt output. Pin polarity is active low.
C3	SDA	I/O	Serial data
C4	SCL	I/O	Serial clock

●Absolute Maximum Ratings

PARAMETER	SYMBOL	RATING	UNIT	CONDITION
Power supply voltage	VDD	-0.3 to 4.5	V	
Input voltage	VIN	-0.3 to VDD+0.3	V	
Power dissipation	Pd	600	mW	(*1)
Storage temperature range	Tstg	-50 to 125	°C	

(*1) Ambient temperature reduces a permission loss by 6.00mW per case more than 25 degree Celsius, 1degree Celsius.

●Recommended Operating Ratings

PARAMETER	SYMBOL	RATING			UNIT	CONDITION
		MIN.	TYP.	MAX.		
Power supply voltage	VDD	1.65	3.00	3.60	V	
Operating temperature range	Topr	-30	25	85	°C	

●Electrical Characteristics

All specifications typical at 25°C, VDD = 3.00V, GND=0.00V unless otherwise noted.

PARAMETER	SYMBOL	RATING			UNIT	CONDITION
		MIN.	TYP.	MAX.		
Low-level input voltage	VIL	-0.3	-	0.3xVDD	V	
High-level input voltage	VIH	0.7xVDD	-	VDD+0.3	V	
Low-level output voltage	VOL	0	-	0.2	V	IL = 3.6mA
High-level output voltage	VOH	VDD-0.2	-	VDD	V	IL = -3.6mA
A/D converter resolution	AD	-	-	12	Bits	Programmable 8/12 bits
Differential non-linearity error	DNL	-3.5	-	3.5	LSB	
Integral non-linearity error	INL	-5	-	5	LSB	
Internal clock frequency	Freq	2.6	4.0	5.1	MHz	
Active current	Idd	-	120	450	uA	8.2kSPS (operation)
Standby current	Ist	-	-	0.8	uA	After reset releasing

●Power On Reset Timing Chart

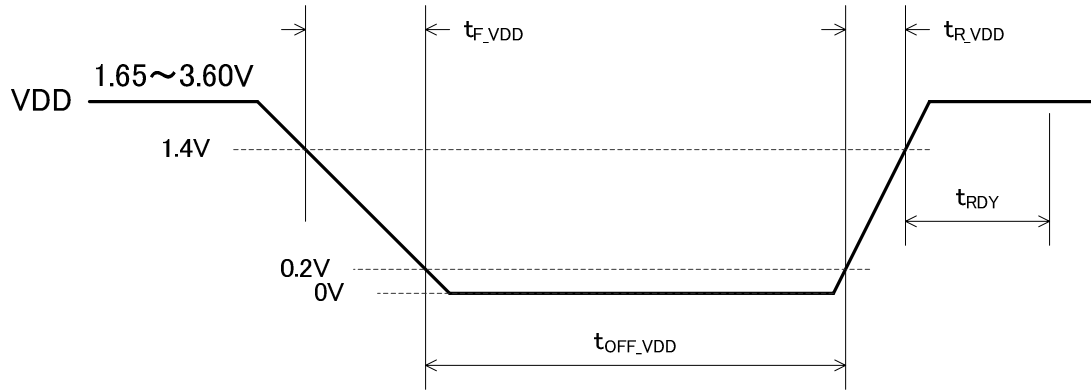

All specifications at 25°C, GND=0.00V unless otherwise noted.

PARAMETER	SYMBOL	RATING			UNIT	CONDITION
		MIN.	TYP.	MAX.		
Off period of VDD	t_{OFF_VDD}	0.3	-	-	s	
Rise time for VDD	t_{R_VDD}	-	-	100	us	
Fall time for VDD	t_{F_VDD}	0.5	-	-	ms	
Ready time for device	t_{RDY}	-	-	2	ms	

●2-wire Serial Interface Timing Chart

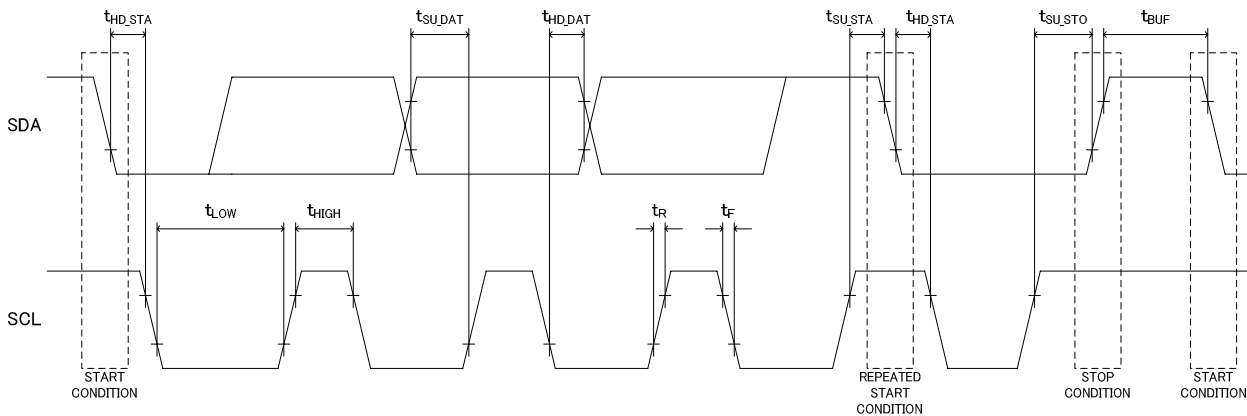

All specifications at 25°C, VDD = 3.00V, GND=0.00V unless otherwise noted.

PARAMETER	SYMBOL	RATING			UNIT	CONDITION
		MIN.	TYP.	MAX.		
SCL clock frequency	f_{SCL}	0	-	400	KHz	
Hold time for (repeated) START condition	t_{HD_STA}	0.6	-	-	us	
Low period of SCL	t_{LOW}	1.3	-	-	us	
High period of SCL	t_{HIGH}	0.6	-	-	us	
Setup time for repeated START condition	t_{SU_STA}	0.6	-	-	us	
Data hold time	t_{HD_DAT}	0	-	0.9	us	
Data setup time	t_{SU_DAT}	100	-	-	ns	
Rise time for both SCL and SDA	t_R	20	-	300	ns	
Fall time for both SCL and SDA	t_F	20	-	300	ns	
Setup time for STOP condition	t_{SU_STO}	0.6	-	-	us	
Bus free time between a STOP and START condition	t_{BUF}	1.3	-	-	us	

●2-wire Serial Interface

BU21025GUL supports a 2-wire serial interface. A device that controls transfer is called a master. A device that controlled by the master is called a slave. BU21025GUL is a slave device.

BU21025GUL has a write protocol and a read protocol. The write protocol consists of a start condition, an address byte, a command byte, and a stop condition. The read protocol consists of a start condition, an address byte, one or two data bytes, and a stop condition.

Start Condition

BU21025GUL recognizes as a start condition that falling edge of SDA while SCL is set "H". If the start condition is received, BU21025GUL will be in the state that can be transfer and received data. When the start condition is fulfilled, BU21025GUL recognize the (repeated) start condition also in data transfer.

Stop Condition

BU21025GUL recognizes as a stop condition that rising edge of SDA while SCL is set "H". If the stop condition is received, BU21025GUL will be in the state that can not be transfer and received data.

Data Transfer

Data is transferred with the most significant bit (MSB) first and 8-bits long. Each byte has to be followed by an acknowledge bit. A Timing of SDA data receiving is rising edge of SCL. A state of SDA can only change when SCL set to "L". If SDA is changed while SCL is set "H", a start or stop condition will be recognized by BU21025GUL.

Acknowledge Bit (sending)

After the master sends a byte to BU21025GUL, an acknowledge bit is used in order that BU21025GUL may return a response to the master. At this time, the master needs to set SDA into a high impedance state. When BU21025GUL receives effectively data, it sets SDA to "L" (ACK). Otherwise SDA is set to "H" (NACK).

Acknowledge Bit (receiving)

After the master receives a byte from BU21025GUL, an acknowledge bit is used for judgment of whether BU21025GUL continues data transfer. In this case, the master needs to set SDA. When SDA is set to "L" (ACK), BU21025GUL continues data transfer. When SDA is set to "H" (NACK), BU21025GUL ends data transfer.

Address Byte

BU21025GUL recognizes one byte data as an address byte after a start condition. The address byte is consisted a 7-bit slave address and a read-write bit. If a received slave address is matched with its one, BU21025GUL issues an acknowledge to the master. Otherwise BU21025GUL doesn't issue an acknowledge to the master and stops data transfer. Upper 5 bits of the 7-bit slave address are "10010". And lower 2 bits of the 7-bit slave address are programmable by AD1 and AD0. The read-write bit (R/WB) determines direction. When it is '1', the master reads from BU21025GUL. When it is '0', the master writes to BU21025GUL.

Table 1. Address Byte

BIT	MSB 7	6	5	4	3	2	1	LSB 0
NAME	S6	S5	S4	S3	S2	S1	S0	R/WB
SLAVE	1	0	0	1	0	AD1	AD0	-

BIT 7-1 : S6-0

Slave address

BIT 0 : R/WB

0: The master writes to BU21025GUL

1: The master reads from BU21025GUL.

Command Byte

BU21025GUL has a command byte after the address byte. Upper 4 bits of the command byte select an operation code. And lower 4 bits of the command byte select an operand. Effects of the operands are changed by the operation code.

Table 2. Command Byte

BIT	MSB 7	6	5	4	3	2	1	LSB 0
NAME	C3	C2	C1	C0	O3	O2	O1	O0

BIT 7-4 : C3-0

Operation code: It is select an operation of the command. Detail is shown in Table 3.

BIT 3-0 : O3-0

Operand: It has 3 types. The operand type is selected by the operation code. When the operation code is not "0101" or "1011", the option type is 0. When it is "1011", the option type is 1. When it is "0101" option type is 2. Detail is shown in Table 3 and 4.

Table 3. Operation Code Function

C3	C2	C1	C0	FUNCTION	AD-INPUT	X-DRIVER	Y-DRIVER	INT POLARITY	OPERAND TYPE
0	0	0	0	Set Power	OFF	OFF	OFF	H	0
0	0	0	1	Reserved	-	-	-	-	-
0	0	1	0	Measure AUX	AUX	OFF	OFF	H	0
0	0	1	1	Reserved	-	-	-	-	-
0	1	0	0	Set Power	OFF	OFF	OFF	H	0
0	1	0	1	Software Reset	OFF	OFF	OFF	H	2
0	1	1	0	Reserved	-	-	-	-	-
0	1	1	1	Reserved	-	-	-	-	-
1	0	0	0	Drive X	OFF	ON	OFF	L	0
1	0	0	1	Drive Y	OFF	OFF	ON	L	0
1	0	1	0	Drive Z	OFF	XN-ON	YP-ON	L	0
1	0	1	1	Setup	Keep	Keep	Keep	Keep	1
1	1	0	0	Measure X	YP	ON	OFF	L	0
1	1	0	1	Measure Y	XP	OFF	ON	L	0
1	1	1	0	Measure Z1	YN	XN-ON	YP-ON	L	0
1	1	1	1	Measure Z2	XP	XN-ON	YP-ON	L	0

Set Power (0000, 0100)

This code is used for returning to a state for touch detection without A/D conversion after sending screen drive command. After this command, A/D converted data is set to 0.

Software Reset (0101)

BU21025GUL resets an A/D converted data, setup settings, and state of analog blocks to the initial state. If BU21025GUL receives this code during an A/D conversion, the A/D conversion is stopped.

Drive X (1000), Drive Y (1001), Drive Z (1010)

BU21025GUL starts driving screen voltage by each code. PD is not effective. So, Driving is continuous until reserving another command that changes state of driving screen voltage.

Measure AUX (0010), Measure X (1100), Measure Y (1101), Measure Z1 (1110), Measure Z2 (1111)

BU21025GUL starts driving screen voltage and A/D conversion. A PD of operand set, state of BU21025GUL after A/D conversion is finished.

Setup (1011)

The setup command has a special operand (type is 1). The operand has MAF and pull-up resistor settings. Detail is shown in Table 4.

Table 4. Operands of Each Type

OPERAND TYPE	O3	O2	C1	C0
0	X	PD	M	X
1	L1	L0	MAF	PU90
2	X	X	X	X

Operand Type 0

O3 : X

Don't care

O2 : PD

Power down setting.

0 : The analog blocks off and touch detection is enable automatically after A/D conversion is finished.

1 : The analog blocks keep measuring state after A/D conversion is finished.

O1 : M

A/D conversion mode setting.

0 : The resolution of A/D conversion is 12-bit. The Conversion clock frequency is 1MHz.

1 : The resolution of A/D conversion is 8-bit. The conversion clock frequency is 2MHz

O0 : X

Don't care

Operand Type 1

O3 -2: L1-0

Fixed. Must write "00".

O1 : MAF

Median Average Filter (MAF) Setting

0 : MAF is enabled (default).

1 : MAF is disabled.

O0 : PU90

pull-up resistor Setting.

0 : 50 kohm (default).

1 : 90 kohm

Operand Type 2

O3 -0: X

Don't care

Write Protocol

An command write is started in BU21025GUL when the master sends the start condition, the slave address of BU21025GUL, and zero in bit 0(8th bit) for writing, as shown in Table 1. If the slave address is matched with its own, BU21025GUL issues an acknowledge to the master. When the master receives the acknowledge from BU21025GUL, the master send the command byte. When BU21025GUL received next 8 bits, it issues another acknowledge to the master. After the acknowledge is received by the master, the master sends the stop or repeated start condition for ending write.

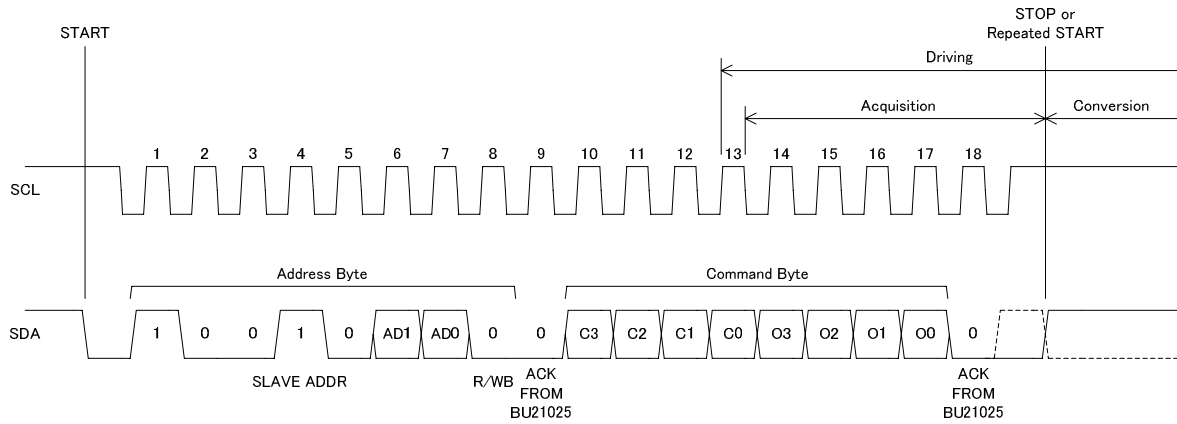

Figure 1. Write Protocol

If a receiving command in BU21025GUL is not the software reset or setup, BU21025GUL starts driving screen voltage when C0 is latched by rising edge of SCL. Next, if the received type of operation code is measurement, BU21025GUL starts acquisition in A/D converter when next falling edge of SCL. BU21025GUL stops acquisition and starts A/D conversion when BU21025GUL receive the stop or repeated start condition.

When BU21025GUL receives a command other than software reset during the A/D conversion, the command is ignored. And if the command is ignored, BU21025GUL doesn't return an acknowledge at the ACK timing behind the command byte. (18th timing in Figure. 1)

Read Protocol

A data read is started in BU21025GUL when the master sends the start condition, the slave address of BU21025GUL, and one in bit 0 (8th bit) for reading, as shown in Table 1. If the slave address is matched with its own, BU21025GUL issues an acknowledge to the master. Next, BU21025GUL send upper 8-bit (D11-4) of an A/D converted 12-bit data as data byte 1 and wait an acknowledge from the master. After receiving the acknowledge, the data byte 2 is sent. Upper 4 bits of it are lower 4 bits (D3-0) of the A/D converted 12-bit data, and lower 4 bits of it are all zero. In next acknowledge timing, the master send a not-acknowledge and the stop or repeated start condition for ending read. In the last acknowledge timing, BU21025GUL doesn't check the acknowledge and stop sending data. So if the master send an acknowledge and continue reading a byte, the read data become 0xFF. In the 8-bit mode, all of an A/D converted 8-bit data is in the data byte 1. So, the master doesn't need to read the data byte 2.

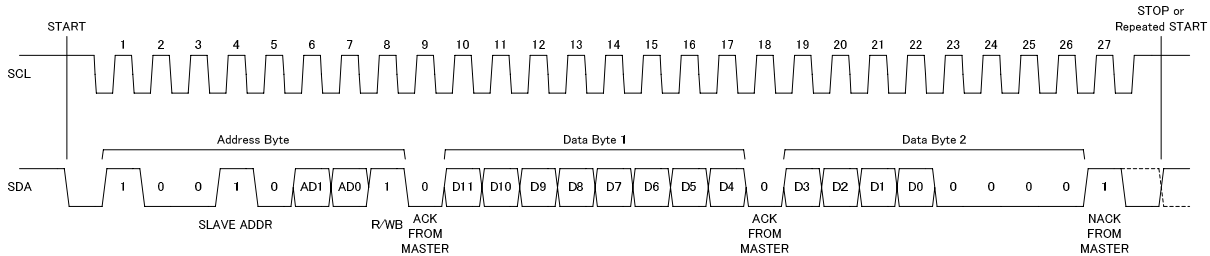

Figure 2. Read Protocol

If an A/D conversion is not finished until falling edge SCL after first acknowledge timing with read mode, SCL pin is stretched by BU21025GUL. In this state, SCL pin is forced to low by BU21025GUL and SDA value is invalid data. This state is ended when the A/D conversion is finished. After this state end, the master can control the SCL line and read converted data.

With stretch function, the master can access immediately after sending a conversion command. If performance of an A/D conversion is needed, the master send the read command after the A/D conversion is finished. Detail of a A/D conversion time is shown in Table 6.

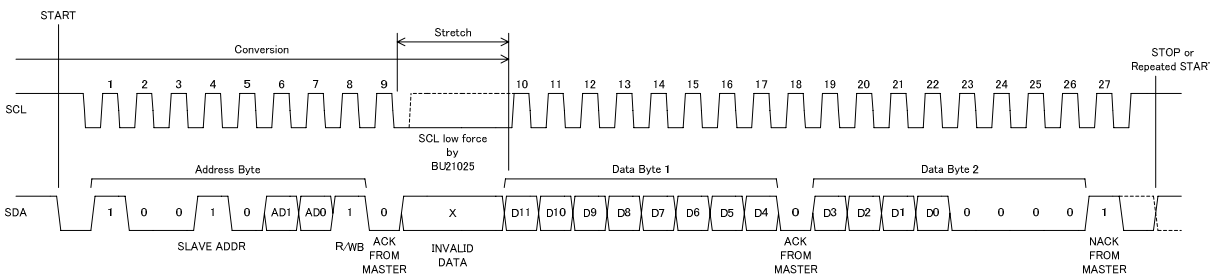
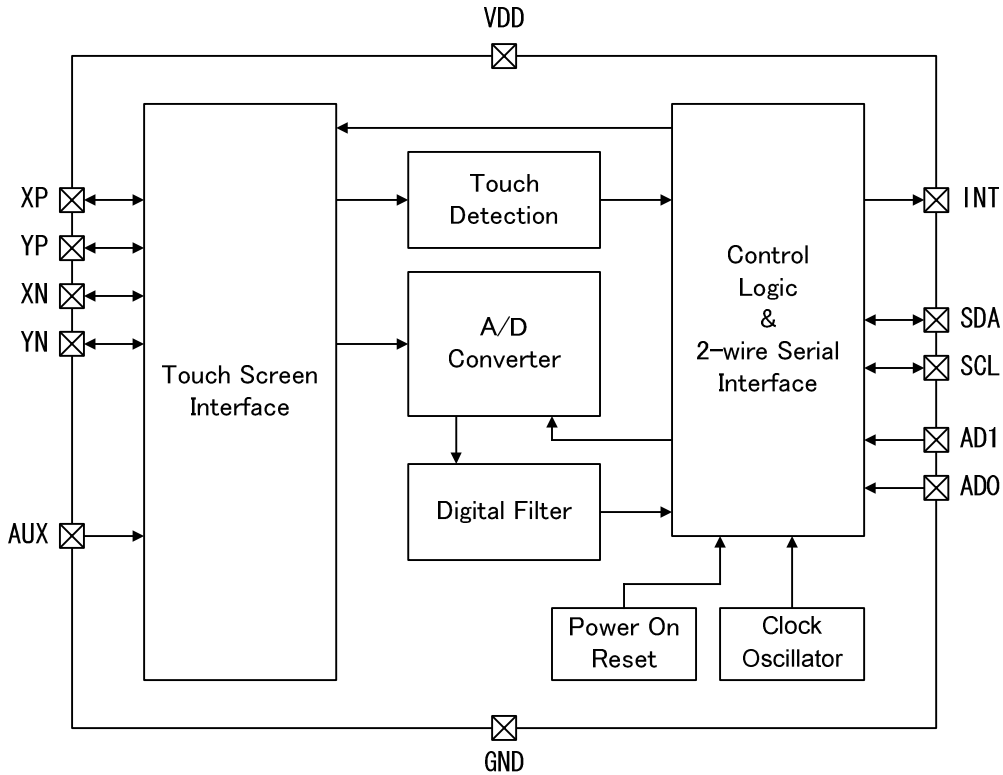

Figure 3. Read with Stretch

●Block Diagram



●Overview

Power On Reset

BU21025GUL requests that the Power On Reset Timing should be observed. If the Power On Reset Timing not be observed, BU21025GUL may wakeup with a random state. The touch detection and 2-wire serial interface is enabled after taking the device ready time.

A/D Converter

BU21025GUL has a 12-bit Successive Approximation Resistor (SAR) Analog to Digital (A/D) converter. This A/D converter is used for measuring X and Y position and Auxiliary input voltage. Output format is in straight binary as shown in Table 5.

Table 5. A/D Converter Output Format

INPUT VOLTAGE	OUTPUT
(VREF - 1.5LSB) ~ VREF	FFFh
(VREF - 2.5LSB) ~ (VREF - 1.5LSB)	FFEh
(VREF - 3.5LSB) ~ (VREF - 2.5LSB)	FFDh
⋮	⋮
1.5LSB ~ 2.5LSB	002h
0.5LSB ~ 1.5LSB	001h
0 ~ 0.5LSB	000h

Note: VREF = VREFP - VREFN, LSB = VREF / 4096

Touch Screen I/F

A touch screen interface is consisted many switches. These switches are used for the driving screen voltage and selection an input of the A/D converter. State of these switches is selected by a command that sent from the master.

Touch Detection

A touch detection function of BU21025GUL is automatically enabled after wakeup. BU21025GUL inform that touch screen is touched or not by INT pin when touch detection is enabled. Output level of INT becomes low during screen is touched. In this state, XP pin is pulled-up high by pull-up resistor (R_{PU}) and YN pin is connected to GND. A resistance of R_{PU} is selectable from either 50 kohm (default) or 90 kohm by the setup command. When the screen isn't touched, XP is connected to VDD trough the pull-up resistor. When the screen is touched, XP is connected to GND trough the screen and BU21025GUL detect touch.

When a received command is not setup (1011), the touch detection is disabled and R_{PU} is disconnected from XP pin. And output level of INT is fixed high or low by each command (see Table 3 for details about operation code).

When BU21025GUL receives software reset command (0101), touch detection is enabled after the 2nd acknowledge timing. When BU21025GUL receives A/D conversion with PD=0 commandn touch detection is enabled after an A/D conversion is finished.

When BU21025GUL receives a driving screen voltage or an A/D conversion with PD=1 command, touch detection is not enable automatically. A method for re-enable the touch detection is sending new command that return to enable touch detection. The set power command is almost same as an A/D conversion command.

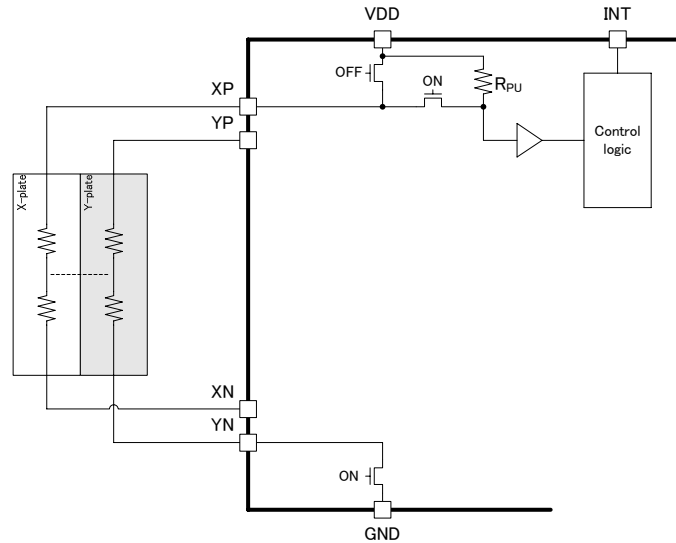

Figure 4. Touch Detection Circuit

Digital Filter

BU21025GUL has a Median Average Filter (MAF) as a digital filter for noise reduction. When the MAF is enabled, BU21025GUL operates A/D conversion 7 times and stores converted data. Next, these stored data are sorted. An output data of MAF is an average value of middle three values of the sorted data. An abnormal value becomes difficult to affect the results. So noise reduction performance of MAF is higher than one of normal average filter. When the MAF is disabled, BU21025GUL operates A/D conversion one times and output the converted data. The MAF is enabled in defaults and is changed by the setup command.

●Operation

Position Detection of Touch Screen

The 4-wire resistive touch screen is mainly constituted in two resistive plates, X and Y. If screen is pressed, these 2 plates are connected.

A position of touch screen is detected by applying voltage to one plate and measuring voltage of another plate. This measurement voltage is divided by touch position. In X-position detection, X-plate is applied voltage. And Voltage of Y-plate is measured. In Y-position detection, Y-plate is applied voltage. And Voltage of Y-plate is measured. The master needs to detection 2 times for detecting X and Y position

When screen is not touched, a measuring plate is high impedance from another plate. So, it can't get voltage. And a value of the A/D conversion became unknown. If unknown values are used for calculating the coordinates, the coordinates will not show touch points. So it is require to filter unknown values when the calculate coordinates.

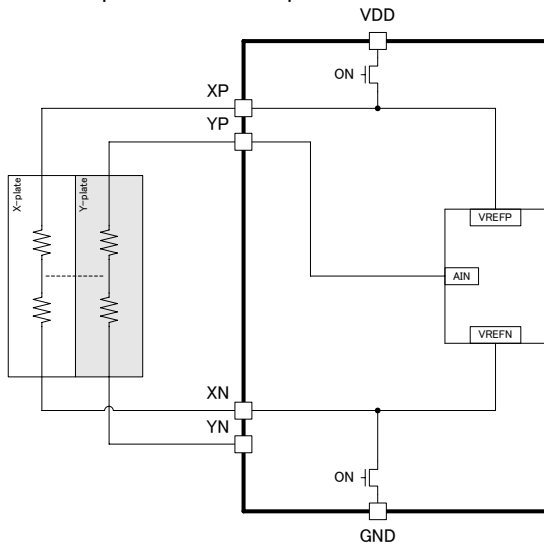

Figure 5. X-Position Detection Mode

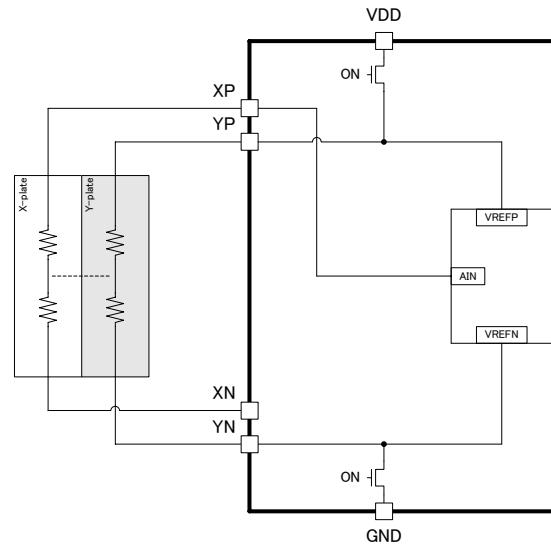

Figure 6. Y-Position Detection Mode

Touch Resistance Measurement

These are two methods for measuring touch resistance. The first method requires that a resistance of X-plate ($R_{X\text{-plate}}$) is known. In this method, the calculation of touch resistance (R_{TOUCH}) needs X position and 2 additional measurement data (Z_1 and Z_2) that shown in Figure 7 and 8. The equation is as follows,

$$R_{TOUCH} = R_{X\text{-plate}} \cdot \frac{X_{\text{position}}}{4096} \left(\frac{Z_2}{Z_1} - 1 \right)$$

The second method requires that both resistance of X-plate and resistance of Y-plate ($R_{Y\text{-plate}}$) are known. In this method, the calculation of R_{TOUCH} needs X and Y position and Z_1 . The equation is as follows,

$$R_{TOUCH} = \frac{R_{X\text{-plate}} - X_{\text{position}}}{4096} \cdot \left(\frac{4096}{Z_1} - 1 \right) - R_{Y\text{-plate}} \cdot \left(1 - \frac{Y_{\text{position}}}{4096} \right)$$

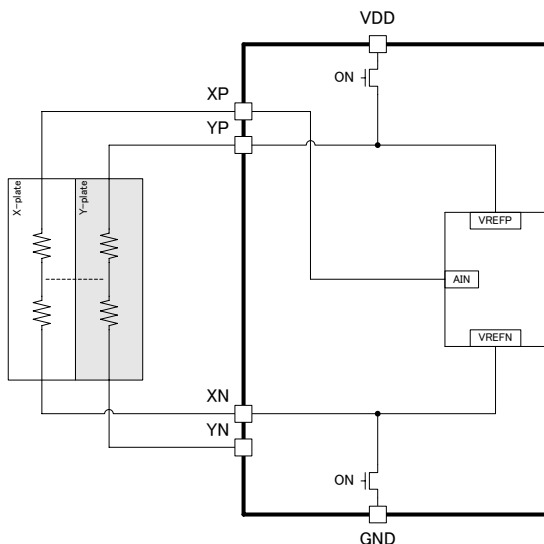

Figure 7. Z1-Position Detection Mode

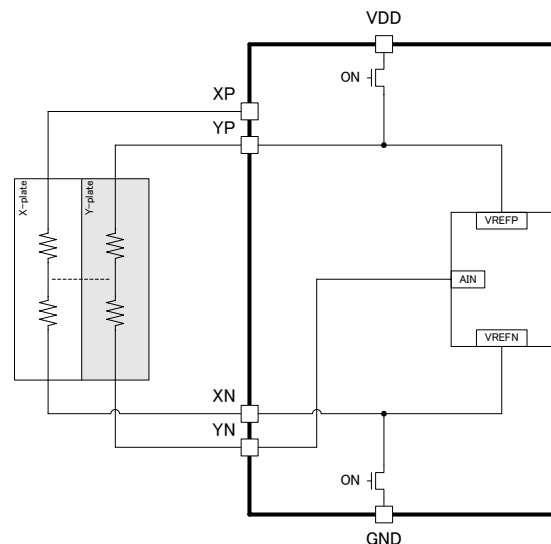

Figure 8. Z2-Position Detection Mode

A/D Conversion Time

When MAF is disabled, an A/D conversion takes 66 internal core clocks (CCLK) with 12-bit mode and 38 CCLK with 8-bit mode. When MAF is enabled, it takes 476 CCLK with 12-bit mode and 244 CCLK with 8-bit mode. In MAF mode, the number of sampling becomes 7. So the A/D conversion cycles become large.

The A/D conversion clocks and time are shown in Table 6. The number of CCLK and time are counted from a stop or repeated start condition after sending a conversion command. In this table, the time is calculated by CCLK is 4MHz in typically.

Table 6. A/D Conversion Time (CCLK = 4MHz)

MAF	MODE	NUMBER OF CCLK	TIME [us]
Enable	12-bit	476	119.0
	8-bit	244	61.0
Disable	12-bit	66	16.5
	8-bit	38	9.5

A/D Sampling Time with 2-wire Serial Interface

The master need to send a conversion command and a read command for getting an A/D converted data. So, a throughput rate is affected by 2-wire serial interface frequency. Each write cycle takes 20 SCL and each read cycle takes 29 SCL (12-bit mode) or 20 SCL (8-bit mode). Note that each a start and a stop condition take 1 SCL in this count.

When the 2-wire serial interface frequency is 400 KHz, one period become 2.5us. Each A/D sampling time takes 241.5us (49 x 2.5 us + 119.0 us) with 12-bit mode and MAF. So, a control throughput rate becomes 4.14 kSPS. In MAF mode, BU21025GUL operates A/D conversion 7 times. It means that an operation throughput rate is increased 7 times. It becomes 28.99 kSPS.

Table 7. Control and Operation Throughput

2-WIRE SERIAL INTERFACE FREQUENCY	MAF	MODE	NUMBER OF SCL	A/D CONVERSION TIME [us]	CYCLE TIME [us]	CONTROL THROUGHPUT [kSPS]	OPERATION THROUGHPUT [kSPS]
100 kHz (10us period)	Enable	12-bit	49	119.0	609.0	1.64	11.49
		8-bit	40	61.0	461.0	2.17	15.18
	Disable	12-bit	49	16.5	506.5	1.97	-
		8-bit	40	9.5	409.5	2.44	-
400 kHz (2.5us period)	Enable	12-bit	49	119.0	241.5	4.14	28.99
		8-bit	40	61.0	161.0	6.21	43.48
	Disable	12-bit	49	16.5	139.0	7.19	-
		8-bit	40	9.5	109.5	9.13	-

•Operational Notes**(1) Absolute Maximum Ratings**

An excess in the absolute maximum ratings, such as supply voltage, temperature range of operating conditions, etc., can break down devices, thus making impossible to identify breaking mode such as a short circuit or an open circuit. If any special mode exceeding the absolute maximum ratings is assumed, consideration should be given to take physical safety measures including the use of fuses, etc.

(2) Operating conditions

These conditions represent a range within which characteristics can be provided approximately as expected. The electrical characteristics are guaranteed under the conditions of each parameter.

(3) Reverse connection of power supply connector

The reverse connection of power supply connector can break down ICs. Take protective measures against the breakdown due to the reverse connection, such as mounting an external diode between the power supply and the IC's power supply terminal.

(4) Power supply line

Design PCB pattern to provide low impedance for the wiring between the power supply and the GND lines. In this regard, for the digital block power supply and the analog block power supply, even though these power supplies has the same level of potential, separate the power supply pattern for the digital block from that for the analog block, thus suppressing the diffraction of digital noises to the analog block power supply resulting from impedance common to the wiring patterns. For the GND line, give consideration to design the patterns in a similar manner. Furthermore, for all power supply terminals to ICs, mount a capacitor between the power supply and the GND terminal. At the same time, in order to use an electrolytic capacitor, thoroughly check to be sure the characteristics of the capacitor to be used present no problem including the occurrence of capacity dropout at a low temperature, thus determining the constant.

(5) GND voltage

Make setting of the potential of the GND terminal so that it will be maintained at the minimum in any operating state. Furthermore, check to be sure no terminals are at a potential lower than the GND voltage including an actual electric transient.

(6) Short circuit between terminals and erroneous mounting

In order to mount ICs on a set PCB, pay thorough attention to the direction and offset of the ICs. Erroneous mounting can break down the ICs. Furthermore, if a short circuit occurs due to foreign matters entering between terminals or between the terminal and the power supply or the GND terminal, the ICs can break down.

(7) Operation in strong electromagnetic field

Be noted that using ICs in the strong electromagnetic field can malfunction them.

(8) Inspection with set PCB

On the inspection with the set PCB, if a capacitor is connected to a low-impedance IC terminal, the IC can suffer stress. Therefore, be sure to discharge from the set PCB by each process. Furthermore, in order to mount or dismount the set PCB to/from the jig for the inspection process, be sure to turn OFF the power supply and then mount the set PCB to the jig. After the completion of the inspection, be sure to turn OFF the power supply and then dismount it from the jig. In addition, for protection against static electricity, establish a ground for the assembly process and pay thorough attention to the transportation and the storage of the set PCB.

(9) Input terminals

In terms of the construction of IC, parasitic elements are inevitably formed in relation to potential. The operation of the parasitic element can cause interference with circuit operation, thus resulting in a malfunction and then breakdown of the input terminal. Therefore, pay thorough attention not to handle the input terminals, such as to apply to the input terminals a voltage lower than the GND respectively, so that any parasitic element will operate. Furthermore, do not apply a voltage to the input terminals when no power supply voltage is applied to the IC. In addition, even if the power supply voltage is applied, apply to the input terminals a voltage lower than the power supply voltage or within the guaranteed value of electrical characteristics.

(10) Ground wiring pattern

If small-signal GND and large-current GND are provided, It will be recommended to separate the large-current GND pattern from the small-signal GND pattern and establish a single ground at the reference point of the set PCB so that resistance to the wiring pattern and voltage fluctuations due to a large current will cause no fluctuations in voltages of the small-signal GND. Pay attention not to cause fluctuations in the GND wiring pattern of external parts as well.

(11) External capacitor

In order to use a ceramic capacitor as the external capacitor, determine the constant with consideration given to a degradation in the nominal capacitance due to DC bias and changes in the capacitance due to temperature, etc.

(12) Rush current

The IC with some power supplies has a capable of rush current due to procedure and delay at power-on. Pay attention to the capacitance of the coupling condensers and the wiring pattern width and routing of the power supply and the GND lines.

(13) Others

In case of use this LSI, please peruse some other detail documents, we called, Technical note, Functional description, Application note.

Status of this document

The Japanese version of this document is formal specification. A customer may use this translation version only for a reference to help reading the formal version.

If there are any differences in translation version of this document formal version takes priority

●Ordering Information

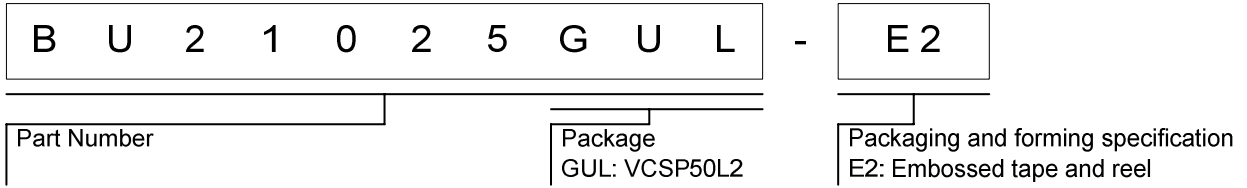

●Physical Dimension Tape and Reel Information

VCSP50L2(BU21025GUL)

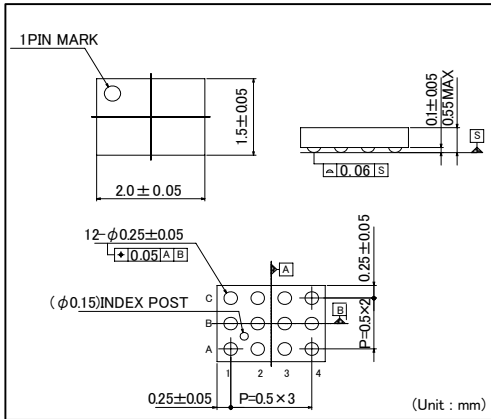

< Tape and Reel information >	
Tape	Embossed carrier tape
Quantity	3000pcs
Direction of feed	E2 (The direction is the 1 pin of product is at the upper left when you hold reel on the left hand and you pull out the tape on the right hand)

* Order quantity needs to be multiple of the minimum quantity.

●Marking Diagram (TOP VIEW)

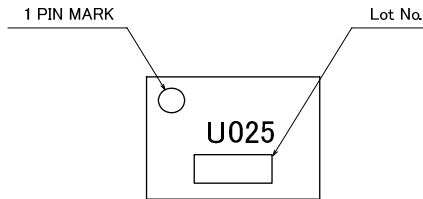

•Revision History

DATE	REVISION	CHANGES
2012/06/28	002	new release

Notice

Precaution on using ROHM Products

- Our Products are designed and manufactured for application in ordinary electronic equipments (such as AV equipment, OA equipment, telecommunication equipment, home electronic appliances, amusement equipment, etc.). If you intend to use our Products in devices requiring extremely high reliability (such as medical equipment ^(Note 1), transport equipment, traffic equipment, aircraft/spacecraft, nuclear power controllers, fuel controllers, car equipment including car accessories, safety devices, etc.) and whose malfunction or failure may cause loss of human life, bodily injury or serious damage to property ("Specific Applications"), please consult with the ROHM sales representative in advance. Unless otherwise agreed in writing by ROHM in advance, ROHM shall not be in any way responsible or liable for any damages, expenses or losses incurred by you or third parties arising from the use of any ROHM's Products for Specific Applications.

(Note1) Medical Equipment Classification of the Specific Applications

JAPAN	USA	EU	CHINA
CLASS III	CLASS III	CLASS II b	CLASS III
CLASS IV		CLASS III	

- ROHM designs and manufactures its Products subject to strict quality control system. However, semiconductor products can fail or malfunction at a certain rate. Please be sure to implement, at your own responsibilities, adequate safety measures including but not limited to fail-safe design against the physical injury, damage to any property, which a failure or malfunction of our Products may cause. The following are examples of safety measures:
 - Installation of protection circuits or other protective devices to improve system safety
 - Installation of redundant circuits to reduce the impact of single or multiple circuit failure
- Our Products are designed and manufactured for use under standard conditions and not under any special or extraordinary environments or conditions, as exemplified below. Accordingly, ROHM shall not be in any way responsible or liable for any damages, expenses or losses arising from the use of any ROHM's Products under any special or extraordinary environments or conditions. If you intend to use our Products under any special or extraordinary environments or conditions (as exemplified below), your independent verification and confirmation of product performance, reliability, etc. prior to use, must be necessary:
 - Use of our Products in any types of liquid, including water, oils, chemicals, and organic solvents
 - Use of our Products outdoors or in places where the Products are exposed to direct sunlight or dust
 - Use of our Products in places where the Products are exposed to sea wind or corrosive gases, including Cl₂, H₂S, NH₃, SO₂, and NO₂
 - Use of our Products in places where the Products are exposed to static electricity or electromagnetic waves
 - Use of our Products in proximity to heat-producing components, plastic cords, or other flammable items
 - Sealing or coating our Products with resin or other coating materials
 - Use of our Products without cleaning residue of flux (even if you use no-clean type fluxes, cleaning residue of flux is recommended); or Washing our Products by using water or water-soluble cleaning agents for cleaning residue after soldering
 - Use of the Products in places subject to dew condensation
- The Products are not subject to radiation-proof design.
- Please verify and confirm characteristics of the final or mounted products in using the Products.
- In particular, if a transient load (a large amount of load applied in a short period of time, such as pulse. is applied, confirmation of performance characteristics after on-board mounting is strongly recommended. Avoid applying power exceeding normal rated power; exceeding the power rating under steady-state loading condition may negatively affect product performance and reliability.
- De-rate Power Dissipation (Pd) depending on Ambient temperature (Ta). When used in sealed area, confirm the actual ambient temperature.
- Confirm that operation temperature is within the specified range described in the product specification.
- ROHM shall not be in any way responsible or liable for failure induced under deviant condition from what is defined in this document.

Precaution for Mounting / Circuit board design

- When a highly active halogenous (chlorine, bromine, etc.) flux is used, the residue of flux may negatively affect product performance and reliability.
- In principle, the reflow soldering method must be used; if flow soldering method is preferred, please consult with the ROHM representative in advance.

For details, please refer to ROHM Mounting specification

Precautions Regarding Application Examples and External Circuits

1. If change is made to the constant of an external circuit, please allow a sufficient margin considering variations of the characteristics of the Products and external components, including transient characteristics, as well as static characteristics.
2. You agree that application notes, reference designs, and associated data and information contained in this document are presented only as guidance for Products use. Therefore, in case you use such information, you are solely responsible for it and you must exercise your own independent verification and judgment in the use of such information contained in this document. ROHM shall not be in any way responsible or liable for any damages, expenses or losses incurred by you or third parties arising from the use of such information.

Precaution for Electrostatic

This Product is electrostatic sensitive product, which may be damaged due to electrostatic discharge. Please take proper caution in your manufacturing process and storage so that voltage exceeding the Products maximum rating will not be applied to Products. Please take special care under dry condition (e.g. Grounding of human body / equipment / solder iron, isolation from charged objects, setting of Ionizer, friction prevention and temperature / humidity control).

Precaution for Storage / Transportation

1. Product performance and soldered connections may deteriorate if the Products are stored in the places where:
 - [a] the Products are exposed to sea winds or corrosive gases, including Cl₂, H₂S, NH₃, SO₂, and NO₂
 - [b] the temperature or humidity exceeds those recommended by ROHM
 - [c] the Products are exposed to direct sunshine or condensation
 - [d] the Products are exposed to high Electrostatic
2. Even under ROHM recommended storage condition, solderability of products out of recommended storage time period may be degraded. It is strongly recommended to confirm solderability before using Products of which storage time is exceeding the recommended storage time period.
3. Store / transport cartons in the correct direction, which is indicated on a carton with a symbol. Otherwise bent leads may occur due to excessive stress applied when dropping of a carton.
4. Use Products within the specified time after opening a humidity barrier bag. Baking is required before using Products of which storage time is exceeding the recommended storage time period.

Precaution for Product Label

QR code printed on ROHM Products label is for ROHM's internal use only.

Precaution for Disposition

When disposing Products please dispose them properly using an authorized industry waste company.

Precaution for Foreign Exchange and Foreign Trade act

Since our Products might fall under controlled goods prescribed by the applicable foreign exchange and foreign trade act, please consult with ROHM representative in case of export.

Precaution Regarding Intellectual Property Rights

1. All information and data including but not limited to application example contained in this document is for reference only. ROHM does not warrant that foregoing information or data will not infringe any intellectual property rights or any other rights of any third party regarding such information or data. ROHM shall not be in any way responsible or liable for infringement of any intellectual property rights or other damages arising from use of such information or data.:
2. No license, expressly or implied, is granted hereby under any intellectual property rights or other rights of ROHM or any third parties with respect to the information contained in this document.

Other Precaution

1. This document may not be reprinted or reproduced, in whole or in part, without prior written consent of ROHM.
2. The Products may not be disassembled, converted, modified, reproduced or otherwise changed without prior written consent of ROHM.
3. In no event shall you use in any way whatsoever the Products and the related technical information contained in the Products or this document for any military purposes, including but not limited to, the development of mass-destruction weapons.
4. The proper names of companies or products described in this document are trademarks or registered trademarks of ROHM, its affiliated companies or third parties.

General Precaution

1. Before you use our Products, you are requested to carefully read this document and fully understand its contents. ROHM shall not be in any way responsible or liable for failure, malfunction or accident arising from the use of any ROHM's Products against warning, caution or note contained in this document.
2. All information contained in this document is current as of the issuing date and subject to change without any prior notice. Before purchasing or using ROHM's Products, please confirm the latest information with a ROHM sales representative.
3. The information contained in this document is provided on an "as is" basis and ROHM does not warrant that all information contained in this document is accurate and/or error-free. ROHM shall not be in any way responsible or liable for any damages, expenses or losses incurred by you or third parties resulting from inaccuracy or errors of or concerning such information.

Компания «Life Electronics» занимается поставками электронных компонентов импортного и отечественного производства от производителей и со складов крупных дистрибьюторов Европы, Америки и Азии.

С конца 2013 года компания активно расширяет линейку поставок компонентов по направлению коаксиальный кабель, кварцевые генераторы и конденсаторы (керамические, пленочные, электролитические), за счёт заключения дистрибьюторских договоров

Мы предлагаем:

- Конкурентоспособные цены и скидки постоянным клиентам.
- Специальные условия для постоянных клиентов.
- Подбор аналогов.
- Поставку компонентов в любых объемах, удовлетворяющих вашим потребностям.
- Приемлемые сроки поставки, возможна ускоренная поставка.
- Доставку товара в любую точку России и стран СНГ.
- Комплексную поставку.
- Работу по проектам и поставку образцов.
- Формирование склада под заказчика.
- Сертификаты соответствия на поставляемую продукцию (по желанию клиента).
- Тестирование поставляемой продукции.
- Поставку компонентов, требующих военную и космическую приемку.
- Входной контроль качества.
- Наличие сертификата ISO.

В составе нашей компании организован Конструкторский отдел, призванный помогать разработчикам, и инженерам.

Конструкторский отдел помогает осуществить:

- Регистрацию проекта у производителя компонентов.
- Техническую поддержку проекта.
- Защиту от снятия компонента с производства.
- Оценку стоимости проекта по компонентам.
- Изготовление тестовой платы монтаж и пусконаладочные работы.



Тел: +7 (812) 336 43 04 (многоканальный)
Email: org@lifeelectronics.ru