

SUCOFLEX 500

Twist and bend it as you wish

Plug,
test,
smile.



When it comes to test and measurement, SUCOFLEX® 526V and SUCOFLEX® 526S assemblies guarantee the highest level of satisfaction. Thanks to their unique cable and connector design, they deliver best-in-class phase and amplitude stability with flexure, movement, temperature and tensile stress in combination with outstanding return and insertion loss up to 26.5 GHz.

Sucoflex 526 product comparison



	Sucoflex_526V	Sucoflex_526S
Applications	Vector network analysers (VNAs) Critical laboratory conditions	Bench top testing, RF production testing, Automated test equipment
Features and benefits	Best-in-class phase and amplitude stability with flexure, movement, temperature and tensile stress	Excellent return- and insertion loss
	Excellent return loss	Phase and amplitude stability with flexure and movement
	Extremely flexible and ease of handling	Abrasion, moisture and dust resistance
	Torque, crush and kink resistance Robust and precise center positioning of 3.5 mm center conductors	
	Precise and repeatable measurements	
	Long service life Reduce total cost of test with durable, reliable performance Increased test efficiency and measurement saving costs due to reduced calibration intervals	
Diameter	13 mm	7.7 mm
Min. bending radius	50 mm	25.4 mm
Available connectors	PC 3.5	PC 3.5, SMA, N
Crush resistance	80 kN/m	26 kN/m
Typ. flex cycles	100.000 2.0 Mio. for slight movements	100.000
Operating temperature	laboratory conditions, analyzer specific (+15 to +30 °C)	-55 to +125°C
RoHS, REACH	Compliant	Compliant
Operating frequency	up to 26.5 GHz	up to 26.5 GHz
Velocity of propagation	80 %	77 %
Return loss	typ. 25 dB min. 20 dB	typ. 25.0 dB min. 19 dB
Insertion loss (25 / 38 / 48 in) @ 26.5 GHz	max. 2.5 / 3.6 / 4.4 dB	typ. 1.63 dB/m incl. connectors max 1.77 dB/m incl. connectors
Screening effectiveness	> 90 dB	> 90 dB
Amplitude stab. vs. movement	max. 0.05 dB	max. ± 0.05 dB
Amplitude stab. vs. flexure	max. 0.08 dB	max. ± 0.05 dB
Phase stability vs. flexure (25 / 38 / 48 in)	max. 3.9 / 7.4 / 10°	typ. ± 3.0°
Phase stab. vs. tensile stress	max. 0.1°/GHz 100 N up to 26.5 GHz	N/A
Phase stab. vs. temperature	typ. 50 ppm +15 °C to +30 °C, 26.5 GHz	typ. 1500 ppm -55°C to + 125°C
Phase matched assemblies available	No	Yes, upon request
New optimised PC3.5 interface supports S-parameter measurements with the highest accuracy	Yes	Yes
Stock assemblies available	Yes	Yes

SUCOFLEX® 526V



The only VNA microwave cable worldwide with a typical 50 ppm phase variation vs. temperature between +15 and +30 °C only. No "PTFE phase knee" at +19 °C as on conventional VNA test cable assemblies which cause phase variations and unstable measurements in critical laboratory conditions.

Available connectors

Product configuration	85069744	85081169	85070046	85081172	85070047	85081177
Cable type	SUCOFLEX 526V					
Length	25" (635 mm)	25" (635 mm)	38" (965 mm)	38" (695 mm)	48" (1219 mm)	48" (1219 mm)
Connector A	3.5 mm ruggedised PORT female					
Connector B	3.5 mm ruggedised DUT male (35VM)	3.5 mm DUT female (35F)	3.5 mm ruggedised DUT male (35VM)	3.5 mm DUT female (35F)	3.5 mm ruggedised DUT male (35VM)	3.5 mm DUT female (35F)

Mechanical data	
Diameter	13 mm
Min. bending	50 mm
Crush resistance	80 kN/m
Flex life	100 000 cycles

Environmental data	
Operating temperature	laboratory conditions, analyser specific (+15 to +30 °C)
RoHS, REACH	compliant

Electrical data			
Impedance	50 Ω		
Operating frequency	up to 26.5 GHz		
Velocity of propagation	80 %		
Time delay	4.15 ns/m		
Return loss	min. 20 dB		
Insertion loss	max. 2.5 dB	max. 3.6 dB	max. 4.4 dB
Screening effectiveness	> 90 dB		
Amplitude stability vs. movement	max. 0.05 dB		
Amplitude stability vs. flexure	max. 0.08 dB		
Phase stability vs. flexure	max. 3.9°	max. 7.4°	max. 10°
Phase stability vs. tensile stress	max. 0.1°/GHz (100 N)		
Phase stability vs. temperature	typ. 50 ppm (+15 to +30 °C)		

Ordering information

Item no.	Description
85069744	SF526V/35VF/35VM/25in
85081169	SF526V/35VF/35F/25in
85070046	SF526V/35VF/35VM/38in
85081172	SF526V/35VF/35F/38in
85070047	SF526V/35VF/35VM/48in
85081177	SF526V/35VF/35F/48in

SUCOFLEX® 526V

Phase shift vs. temperature (+15°C to +30°C)

Assembly length (in (mm))	Frequency (GHz)*	SUCOFLEX 526V	Conventional VNA test lead
25 (635)	18	0.9	11.4
25 (635)	26.5	1.3	16.7

*Other frequencies on request

Phase stability vs. temperature performance



Phase stability vs. flexure

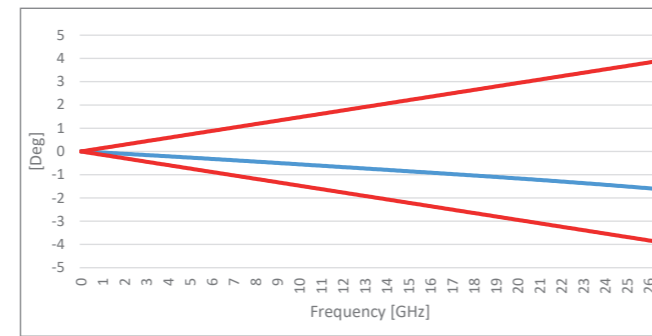

Insertion Loss



Loss stability vs. flexure

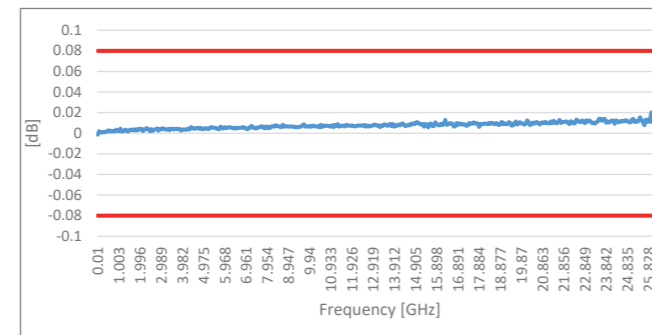

Return Loss SUCOFLEX 526V with two straight PC3.5 connectors



Connector configuration

35 VF (3.5 mm ruggedized PORT female)

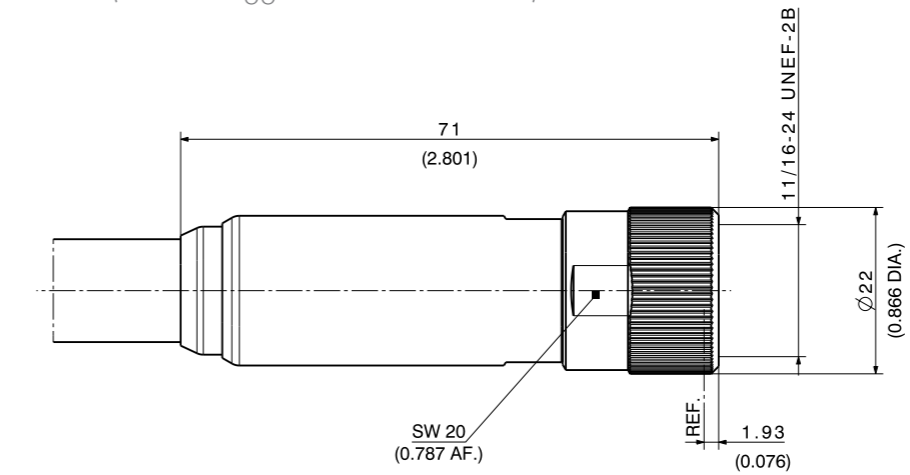

35 VM (3.5 mm ruggedized DUT male)



35F (3.5mm DUT female)



SUCOFLEX® 526S



The SUCOFLEX 526S is the top performance cable assembly for various applications in test laboratories. When it comes to test and measurement, SUCOFLEX 526S assemblies guarantee the highest level of satisfaction. Thanks to their unique cable and connector design, they deliver best-in-class phase and amplitude stability with flexure in combination with outstanding return and insertion loss up to 26.5 GHz.

Cable Construction

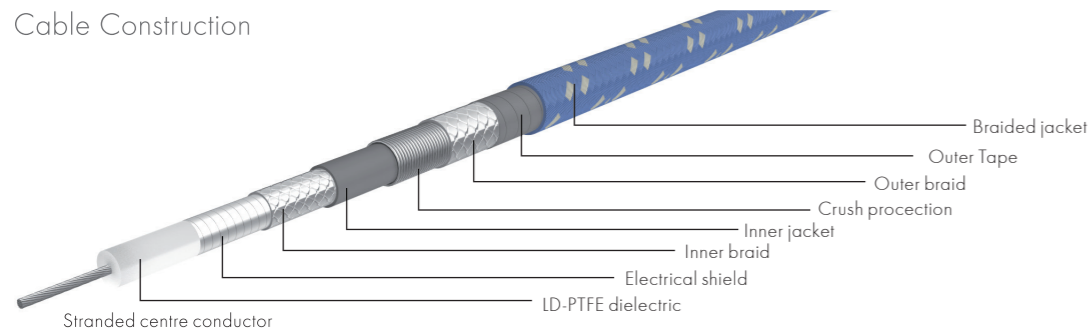

Mechanical data	
Diameter	7.7 mm
Min. bending	25.4 mm
Crush resistance	26 kN/m
Flex life	100 000 cycles
Environmental data	
Operating temperature	-55 to +125 °C
RoHS, REACH	compliant
Electrical data	
Impedance	50 Ω
Operating frequency	up to 26.5 GHz
Velocity of propagation	77 %
Time delay	4.15 ns/m
Return loss	min. 19 dB
Insertion loss	typ. 1.63 dB/m incl. connectors, max 1.77 dB/m incl. connectors
Screening effectiveness	> 90 dB
Amplitude stability vs. movement	max. ± 0.05 dB
Amplitude stability vs. flexure	max. ± 0.05 dB
Phase stability vs. flexure	typ. ± 3°
Phase stability vs. temperature	typically 1500 ppm (-55 to +125 °C)

Ordering information

Item no.	Stock assembly type	
85090623	SF526S/11PC35/11PC35/500mm	PC3.5 male/ PC3.5 male
85088164	SF526S/11PC35/11PC35/36inch	PC3.5 male/ PC3.5 male
85090624	SF526S/11PC35/11PC35/1000mm	PC3.5 male/ PC3.5 male
85090625	SF526S/11PC35/11PC35/2000mm	PC3.5 male/ PC3.5 male
85090626	SF526S/11PC35/11PC35/3000mm	PC3.5 male/ PC3.5 male
85090629	SF526S/11PC35/21PC35/36inch	PC3.5 male/ PC3.5 female
85091104	SF526S/11PC35/21PC35/48inch	PC3.5 male/ PC3.5 female
85089172	SF526S/11N/11N/1000mm	N male/ N male
85089173	SF526S/11SMA/11SMA/1000mm	SMA male/ SMA male

SUCOFLEX® 526S

Available connectors

Connector	Series, pattern	HUBER+SUHNER connector type	Operating frequency (GHz)
PC 3.5	Straight cable plug	11_PC-3.5	26.5
	Straight cable jack	21_PC-3.5	
N	Straight cable plug	11_N	18
	Straight cable jack	21_N	
SMA	Straight cable plug	11_SMA	18

Phase vs. stability vs flexure



Loss stability vs. flexure



Insertion Loss

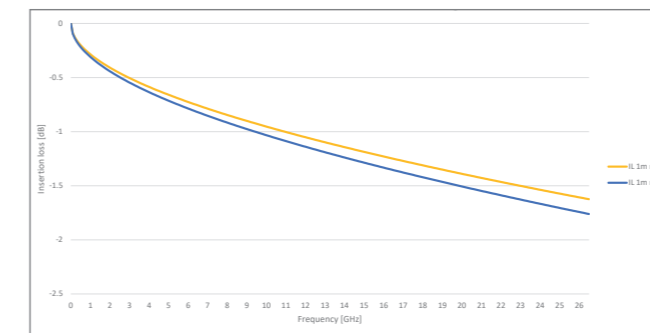

Return Loss SUCOFLEX 526S with two straight PC3.5 connectors



Connector configuration

11PC 3.5

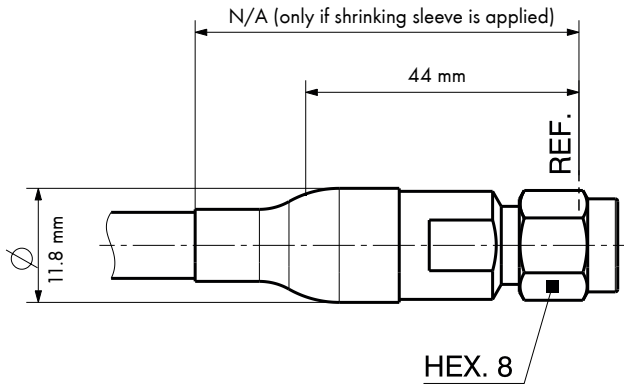

21PC 3.5

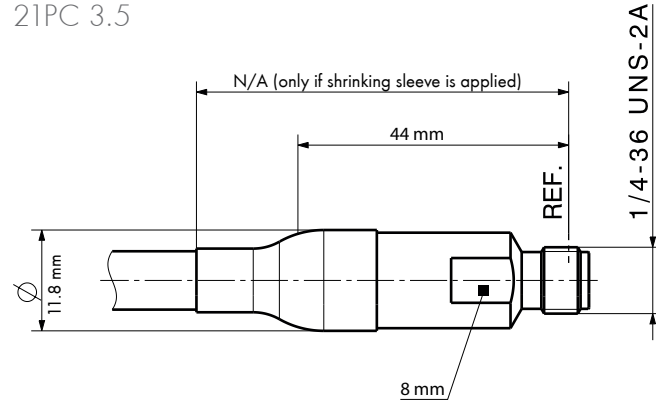

11N

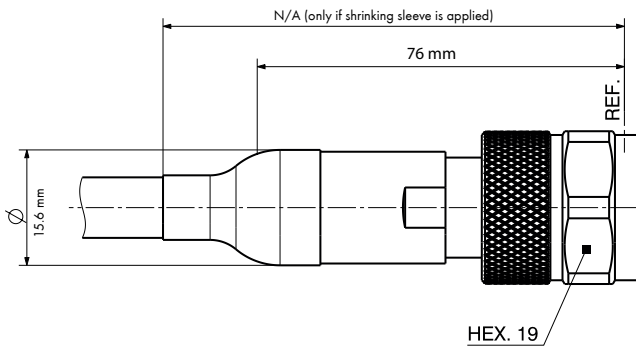

21N

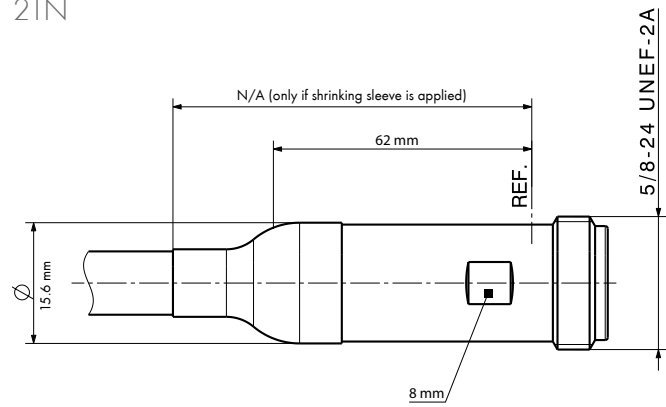

11SMA

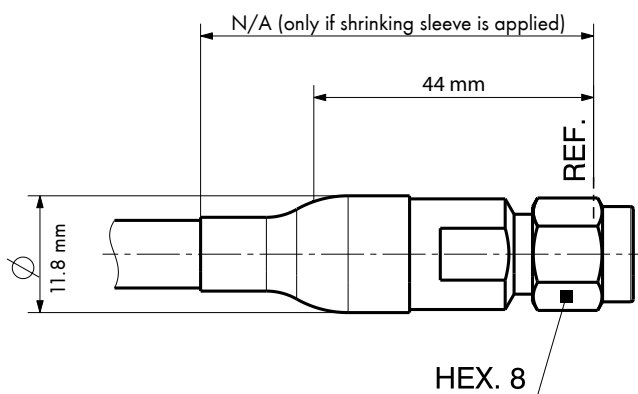

Компания «Life Electronics» занимается поставками электронных компонентов импортного и отечественного производства от производителей и со складов крупных дистрибьюторов Европы, Америки и Азии.

С конца 2013 года компания активно расширяет линейку поставок компонентов по направлению коаксиальный кабель, кварцевые генераторы и конденсаторы (керамические, пленочные, электролитические), за счёт заключения дистрибьюторских договоров

Мы предлагаем:

- Конкурентоспособные цены и скидки постоянным клиентам.
- Специальные условия для постоянных клиентов.
- Подбор аналогов.
- Поставку компонентов в любых объемах, удовлетворяющих вашим потребностям.
- Приемлемые сроки поставки, возможна ускоренная поставка.
- Доставку товара в любую точку России и стран СНГ.
- Комплексную поставку.
- Работу по проектам и поставку образцов.
- Формирование склада под заказчика.
- Сертификаты соответствия на поставляемую продукцию (по желанию клиента).
- Тестирование поставляемой продукции.
- Поставку компонентов, требующих военную и космическую приемку.
- Входной контроль качества.
- Наличие сертификата ISO.

В составе нашей компании организован Конструкторский отдел, призванный помогать разработчикам, и инженерам.

Конструкторский отдел помогает осуществить:

- Регистрацию проекта у производителя компонентов.
- Техническую поддержку проекта.
- Защиту от снятия компонента с производства.
- Оценку стоимости проекта по компонентам.
- Изготовление тестовой платы монтаж и пусконаладочные работы.



Тел: +7 (812) 336 43 04 (многоканальный)
Email: org@lifeelectronics.ru