

# 3M™ MicroTouch™ Controller EX USB Reference Guide

| Model | Size  | Cased | Connector |
|-------|-------|-------|-----------|
| EX111 | 1 X 2 | NO    | AMP       |
| EX121 | 2 X 3 | NO    | 12 PIN    |
| EX141 | 2 X 3 | YES   | 12 PIN    |
| EX151 | 1 X 2 | NO    | ZIF       |

Read and understand all safety information  
contained in this document before using this product.

***MicroTouch™***

**3M**

The information in this document is subject to change without notice. No part of this document may be reproduced or transmitted in any form or by any means, electronic or mechanical, for any purpose, without the express written permission of 3M Touch Systems, Inc. 3M may have patents or pending patent applications, trademarks, copyrights, or other intellectual property rights covering subject matter in this document. The furnishing of this document does not give you license to these patents, trademarks, copyrights, or other intellectual property except as expressly provided in any written license agreement from 3M Touch Systems, Inc.

The information provided in this document is intended as a guide only. For the latest detailed engineering specifications, please contact your 3M Touch Systems, Inc. Application Engineer. 3M Touch Systems, Inc. is committed to continually improving product designs. As a result, product specifications may be subject to change without notification.

"RoHS compliant 2011/65/EU" means that the product or part does not contain any of the following substances in excess of the following maximum concentration values in any homogeneous material, unless the substance is in an application that is exempt under RoHS: (a) 0.1% (by weight) for lead, mercury, hexavalent chromium, polybrominated biphenyls or polybrominated diphenyl ethers; or (b) 0.01% (by weight) for cadmium. This information represents 3M's knowledge and belief, which may be based in whole or in part on information provided by third party suppliers to 3M.

**NOTICE:** Given the variety of factors that can affect the use and performance of a 3M Touch Systems, Inc. product (the "Product"), including that solid state equipment has operation characteristics different from electromechanical equipment, some of which factors are uniquely within User's knowledge and control, it is essential that User evaluate the 3M Touch Systems, Inc. Product and software to determine whether it is suitable for User's particular purpose and suitable for User's method of application. 3M Touch Systems, Inc. statements, engineering/technical information, and recommendations are provided for User's convenience, but their accuracy or completeness is not warranted. 3M Touch Systems, Inc. products and software are not specifically designed for use in medical devices as defined by United States federal law. 3M Touch Systems, Inc. products and software should not be used in such applications without 3M Touch Systems, Inc. express written consent. User should contact its sales representative if User's opportunity involves a medical device application.

**IMPORTANT NOTICE TO PURCHASER:** Specifications are subject to change without notice. These 3M Touch Systems, Inc. Products and software are warranted to meet their published specifications from the date of shipment and for the period stated in the specification. **3M Touch Systems, Inc. makes no additional warranties, express or implied, including but not limited to any implied warranties of merchantability or fitness for a particular purpose.** User is responsible for determining whether the 3M Touch Systems, Inc. Products and software are fit for User's particular purpose and suitable for its method of production, including intellectual property liability for User's application. If the Product, software or software media is proven not to have met 3M Touch Systems, Inc. warranty, then 3M Touch Systems, Inc. sole obligation and User's and Purchaser's **exclusive remedy**, will be, at 3M Touch Systems, Inc. option, to repair or replace that Product quantity or software media or to refund its purchase price. 3M Touch Systems, Inc. has no obligation under 3M Touch Systems, Inc. warranty for any Product, software or software media that has been modified or damaged through misuse, accident, neglect, or subsequent manufacturing operations or assemblies by anyone other than 3M Touch Systems, Inc. **3M Touch Systems, Inc. shall not be liable in any action against it in any way related to the Products or software for any loss or damages, whether non-specified direct, indirect, special, incidental or consequential (including downtime, loss of profits or goodwill) regardless of the legal theory asserted.**

© 3M 2001-2011 All rights reserved.

Document Title: *3M™ MicroTouch™ Controller EX USB Reference Guide*

Document Number: TSD-29489, Version F

3M, the 3M logo, MicroTouch, and the MicroTouch logo are either registered trademarks or trademarks of 3M in the United States and/or other countries.

Windows and/or other Microsoft products referenced herein are either registered trademarks or trademarks of Microsoft Corporation in the U.S. and/or other countries.

All other trademarks are the property of their respective owners.

# Contents

## Contents

### Chapter 1

#### Introduction

|   |   |
|---|---|
| What You Need to Know .....             | 5 |
| Important Safety Information .....      | 5 |
| Sensor Care and Cleaning .....          | 6 |
| 3M Touch Systems Support Services ..... | 7 |
| Contact 3M Touch Systems .....          | 7 |

### Chapter 2

#### Integrating the 3M™ MicroTouch™ EX USB Controllers

|  |    |
|--|----|
| Overview of the EX USB Controllers.....  | 8  |
| Handling and ESD Protection .....        | 9  |
| Establishing the Data Connection .....   | 9  |
| EX121/EX141 Sensor Connections .....     | 10 |
| EX111 Sensor Connections.....            | 10 |
| EX151 Sensor Connections.....            | 11 |
| Mounting the Controller.....             | 12 |
| Supplying Power to the Controller.....   | 12 |
| Mounting the Sensor .....                | 12 |
| Turning On Your System .....             | 12 |
| Status Light (LED) Diagnostics .....     | 13 |
| Installing 3M™ MicroTouch™ Software..... | 14 |

### Chapter 3

#### 3M™ MicroTouch™ EX USB Controller Communications

|   |    |
|---|----|
| Overview of USB Firmware Commands ..... | 15 |
| Communicating with the Controller.....  | 16 |
| Vendor Requests .....                   | 16 |

|   |    |
|---|----|
| Sending Commands to the Controller .....    | 17 |
| Receiving Reports from the Controller ..... | 17 |
| Coordinate Data Report 1.....               | 18 |
| Calibration Request 4.....                  | 19 |
| Controller Status Request 6.....            | 20 |
| Controller Status Report 6.....             | 21 |
| Reset Request 7 .....                       | 23 |
| Restore Defaults Request 8 .....            | 24 |
| Controller ID Request 10 .....              | 25 |
| Controller ID Report 12 .....               | 25 |
| Read Parameter Request 16 .....             | 27 |
| Parameter Data Report 4 .....               | 28 |

## Appendix A

### EX121/EX141 Controller Specifications

|                                |    |
|--------------------------------|----|
| EX121/EX141Dimensions .....    | 29 |
| Technical Specifications ..... | 31 |
| Physical Dimensions .....      | 31 |

## Appendix B

### EX111/EX151 Controller Specifications

|                                 |    |
|---------------------------------|----|
| Figure 3 EX111 Dimensions ..... | 33 |
| Technical Specifications .....  | 36 |
| Physical Dimensions .....       | 36 |

## CHAPTER 1

# Introduction

3M Touch Systems offers several advanced controllers designed for reliability and easy installation. Each controller provides superior performance and delivers excellent stability, sensitivity, accuracy, and fast response.

This reference guide, designed for developers of touch systems, provides installation and configuration information for the 3M™ MicroTouch™ EX USB capacitive touch controller. This document includes information on integrating the EX USB controller into your design, communicating with the controller, installing the MT 7 software user interface, and troubleshooting setup problems. It also includes a complete description of the firmware commands and controller specifications.

3M Touch Systems is committed to being a premier supplier in touch systems throughout the world. As a 3M Touch Systems customer, you are aware that we have strong internal programs that meet or exceed environmental regulations of our customers and the regions in which we conduct business.

## What You Need to Know

This document assumes you are familiar with firmware commands and how to use them. Executing some commands may alter the performance of your touch product. You should be aware of the results of using these commands before executing them.

## Important Safety Information

Read, understand and follow all safety information before using this product. Follow all instructions marked on the product and described in this document. Pay close attention to the following installation warnings and safety precautions.

| <b>Intended Use</b>   |
|---|
| The EX USB controller was designed to enable surface capacitive touch in conjunction with other 3M™ MicroTouch™ sensor products and was tested to replace an existing USB controller. This controller is not suitable for use in hazardous locations. |

### Explanation of Signal Word Consequences

**⚠ WARNING:** Indicates a potentially hazardous situation, which, if not avoided, could result in death or serious injury and/or property damage.

**⚠ CAUTION:** Indicates a potentially hazardous situation, which, if not avoided, may result in minor or moderate injury and/or property damage.

**CAUTION:** Indicates a potentially hazardous situation, which, if not avoided, may result in property damage.

### ⚠ WARNING

**To reduce the risk of fire and/or explosion which could result in serious injury or death:**

Do not install or use this product in a hazardous location.

**To reduce the risk of fire and/or explosion which could result in serious injury or property damage:**

Do not use this product in any outdoor environment unless NEMA standards (or similar standards such as IP rating) are followed.

**To avoid the risk of electric shock which could result in serious injury or death:**

- Do not use a damaged power supply.
- Do not use a power cord that is frayed or otherwise damaged.

### ⚠ CAUTION

**To reduce the risks associated with improper disposal, which if not avoided may result in minor or moderate injury from ground water contamination:**

Dispose of components in accordance with federal, state and local regulations.

**To reduce the risk of possible environmental contamination which may result in minor or moderate injury:**

Dispose of the display in accordance with federal, state and local regulations.

**To reduce the risk of the potentially hazardous situations associated with the use of isopropyl alcohol which may result in minor or moderate injury or property damage:**

Follow all instructions and recommendations in the manufacturer's Material Safety Data Sheet and product label.

## Sensor Care and Cleaning

The sensor requires very little maintenance. 3M Touch Systems recommends that you periodically clean the glass surface.

Typically, an isopropyl alcohol and water solution ratio of 50:50 is the best cleaning agent for your touch screen. You can also use straight isopropyl alcohol. Be sure to follow solvent manufacturer's precautions and directions for use when using any solvents.

- It is important to avoid using any caustic chemicals on the sensor.

- Always dampen the cloth and then clean the screen. Be sure to spray the cleaning liquid onto the cloth, not the screen, so that drips do not seep inside the display or stain the bezel.
- Apply the cleaner with a soft, lint-free cloth. Avoid using gritty cloths.
- Always handle the sensor with care. Do not pull on or stress flex tail.

## 3M Touch Systems Support Services

3M Touch Systems provides extensive support services through our website and technical support organization. Visit the 3M Touch Systems website at <http://www.3M.com/touch>, where you can download touch software and drivers, obtain regularly updated technical documentation on 3M Touch Systems products, and learn more about our company.

Whenever you contact Technical Support, please provide the following information:

- Touch display size, part number and serial number
- Current driver version
- Operating system used
- Information on additional peripherals

Technical Support is available Monday through Friday 8:30 a.m. to 5:30 p.m. with limited call back service after 5:30 p.m. until 8:00 p.m. US Eastern Standard Time – 9 a.m. to 5 p.m. throughout Europe.

You can contact 3M Touch Systems Technical Support (US only -- Eastern Standard Time) by calling the hot line, sending email or a fax.

- Technical Support Hot Line: 978-659-9200
- Technical Support Fax: 978-659-9400
- Toll Free: 1-866-407-6666 (Option 3)
- Email: US-TS-techsupport@mmm.com

## Contact 3M Touch Systems

Contact information for all offices can be found on our website at:

<http://www.3M.com/touch/>

## CHAPTER 2

# Integrating the 3M™ MicroTouch™ EX USB Controllers

The 3M™ MicroTouch™ EX USB controller provides a drop-in replacement for an existing controller with wide dynamic range, increased noise immunity, wide operating temperature stability, reprogrammability using software utilities and improved capability in ungrounded environments.

The firmware for the EX1N1 series USB controllers is optimized for surface capacitive sensors integrated in the latest displays.

This chapter covers the following EX controller specifications:

- Cable connections
- Mounting requirements
- Power requirements and options
- Status LED codes

## Overview of the EX USB Controllers

---

**Note:** For complete specifications for each of these EX USB controllers, refer to the appendices at the end of this manual.

---

The EX II ASIC has a built-in Universal Serial Bus (USB) full speed interface. A full speed USB interface has a data rate of 12 Mb/s. The USB core in the ASIC was designed to USB specification revision 1.1 but is forward compatible with revision 2.0.

A 25-point linearization procedure has been performed to determine the physical properties of the sensor, and the data is stored in a 2D bar code label attached to the flex tail.

To integrate and test the EX USB controller, you need the following items:



- A 3M™ MicroTouch™ surface capacitive sensor (available in a variety of sizes).
- A method of establishing the USB data communication between the controller and your system. The standard 3M™ MicroTouch™ USB cable (P/N 7319420) is recommended for this device.
- The controller will operate with the standard USB +5V bus power.
- A touch driver and a calibration program. You can use 3M™ MicroTouch™ MT 7 software which includes the necessary touch driver and utilities software.

## Handling and ESD Protection

When mounting the sensor and controller, use normal precautions for handling electrostatic sensitive devices. The EX USB controllers have internal protection to  $\pm 27$  kV for ESD discharges to the sensor (not to the controller directly) that may occur during normal operation of the sensor. Refer to the appendices for further specifications.

## Establishing the Data Connection

The EX USB controller requires a 3M™ MicroTouch™ USB communication cable (P/N 7319420) or an equivalent interconnect. One end of this cable plugs into the USB connector (JP1) on the EX USB controller. The other end plugs into a USB port on your PC with a Type-A connector. Table 1 describes the interconnections of the 3M™ MicroTouch™ USB cable.

**Table 1. USB Cable for EX USB Controllers**

| PC Side (USB Type A) |                    | Wire          | Controller Side (5-Pin Molex) |  |
|----------------------|--------------------|---------------|-------------------------------|--|
| Pin                  | USB Assigned       | Color         | Pin                           | Description  |
| 1                    | +5VDC              | Red           | 1                             | +5VDC input power  |
| 2                    | Data (DN)          | Gray          | 2                             | Data (DN) differential pair  |
| 3                    | Data (DP)          | Green         | 3                             | Data (DP) differential pair  |
| 4                    | 0V                 | Black         | 4                             | Power return   |
| 5                    | Cable Shield Shell | Charcoal Gray | 5                             | Outer cable shield around signal and power lines. Chassis (earth) ground |

## EX121/EX141 Sensor Connections

The sensor cable has a 12-pin (2 x 6) dual row female connector that plugs into the controller. Table 2 describes the pins on this connector. The sensor connector always exits towards the USB cable.

**Table 2. Sensor Cable Connector for EX121/EX141 Controllers**

| Pin | Wire Color                    | Description  |
|-----|-------------------------------|--|
| 1   | ———                           | NOVRAM interface   |
| 2   | ———                           | NOVRAM interface   |
| 3   | ———                           | NOVRAM interface   |
| 4   | ———                           | +5 VDC   |
| 5   | Gray                          | Not used   |
| 6   | Green                         | Chassis (earth) ground   |
| 7   | Orange                        | Not used   |
| 8   | Brown Cable shield/drain wire | Connects to the flex tail shield, which must not be grounded because the controller drives the flex tail shield with an AC waveform. |
| 9   | White                         | Upper right (UR) corner  |
| 10  | Red                           | Lower right (LR) corner  |
| 11  | Black                         | Upper left (UL) corner   |
| 12  | Blue                          | Lower left (LL) corner   |

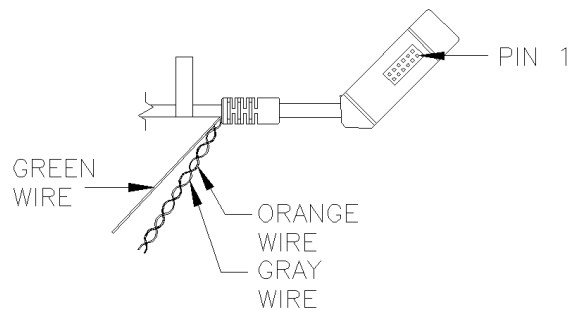

## EX111 Sensor Connections

The sensor cable has a 5-pin single row locking female connector that plugs into the controller. Table 3 describes the pins on this connector.

**Table 3. Sensor Flex Tail Connector for EX111 Controllers**

| Pin | Description  |
|-----|--|
| 1   | Upper left (UL) corner   |
| 2   | Upper right (UR) corner  |
| 3   | Connects to the flex tail shield, which must not be grounded because the controller drives the flex tail shield with an AC waveform. |
| 4   | Lower right (LR) corner  |
| 5   | Lower left (LL) corner   |

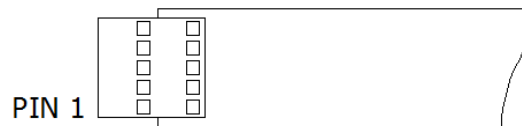

## EX151 Sensor Connections

The sensor cable has a 5-pin ZIF connector that plugs into the controller. Table 4 describes the pins on this connector.

**Table 4 Sensor Cable Connector for EX151 Controllers**

| Pin | Wire Color              | Description  |
|-----|-------------------------|--|
| 1   |                         | Upper left (UL) corner   |
| 2   |                         | Upper right (UR) corner  |
| 3   | Cable shield/drain wire | Connects to the flex tail shield, which must <i>not</i> be grounded because the EX112 drives the flex tail shield with an AC waveform. |
| 4   |                         | Lower right (LR) corner  |
| 5   |                         | Lower left (LL) corner   |

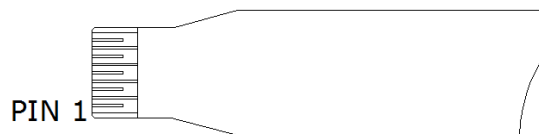

## Mounting the Controller

The cased controller is mounted externally. The uncased controller is mounted internally. Choose a convenient spot away from high-voltage, high power cables and electronics. Use 4-40 plastic screws to mount the cased controller to eliminate possible ESD input path. Metal or plastic screws can be used on the 2x3 board if the green ground wire is used. Metal screws are required on the 1x2 board if a separate ground wire is not used.

The controller should be mounted in line with the sensor flex tail exit point to minimize flexing. Refer to Figure 1 for more details on controller mounting.

## Supplying Power to the Controller

The controller is designed to use USB bus power (that is, tap power from the USB port). The source must deliver 75 mA typical -- 100 mA maximum, with a maximum ripple and noise of 50mV peak-to-peak.



### CAUTION

**To avoid possible damage to the controller**, you must provide a path for electrostatic discharge. The controller-mounting hole near the sensor connector should be used to connect to chassis safety ground and must be attached by the shortest possible route to a good earth return (chassis) in all applications.

## Mounting the Sensor

There are several methods for mounting the sensor depending on your application. If you need instructions or recommendations from 3M Touch Systems on how to incorporate a sensor into your design, refer to the *3M™ MicroTouch™ System 3250EX Integration Guide* (P/N 19-278). All 3M Touch Systems documentation is available from the corporate website at [www.3Mtouch.com](http://www.3Mtouch.com).

## Turning On Your System

Before you turn on your custom system, ensure that all cables are connected properly and that the controller is properly mounted.

To start up your system:

1. Turn on your display and computer.
2. Adjust the contrast and brightness to suit your personal preference and working environment.
3. Adjust the horizontal and vertical position controls on the display to center the image on the sensor.

If the driver has been previously loaded, the controller will enumerate when hot plugging the controller into a USB port.

## Status Light (LED) Diagnostics

3M™ MicroTouch™ controllers are highly reliable units; however, there may be occasions when the controller does not perform exactly as you expected. The EX USB controller provides diagnostic feedback with a light emitting diode (LED) on the component side of the board that indicates the status of the touch system.

If the LED is on, and remains dimly lit, the controller has power and is operating properly. If the LED is off, the controller is not receiving power or USB communications have stopped and the controller is in suspend mode.

The LED indicator also provides visual indication of the controller's internal self-tests by flashing or blinking a code that may be interpreted using the table below. The test results are also returned as part of the USB Status report. Those bits that result in a flashing error code are repeated in the table below.

Some errors are fatal -- that is, normal sensor operation cannot occur. Others errors may simply cause "default conditions" to be assumed and sensor operation may proceed.

**Table 4. LED Diagnostic Codes for EX USB Controllers**

| Self Test Condition         | LED Flashes | Self Test Bit | Description   | What to do...   |
|-----------------------------|-------------|---------------|---|---|
| RAM Data Error <sup>2</sup> | 1           | 0             | Data side checksum error                                | Reload program code.  |
| RAM Code Error <sup>2</sup> | 2           | 1             | Firmware EEPROM checksum verification error             | Reload program code.  |
| STRAY Error <sup>1</sup>    | 3           | 2             | Unable to initialize stray cancellation                 | Replace controller. If error reoccurs, might be a sensor problem.   |
| NOV Error <sup>3</sup>      | 4           | 3             | Parameters invalid (using defaults)                     | Restore defaults. If fault persists, replace controller. If error reoccurs, might be a sensor or cable problem. |
| HDW Error <sup>1</sup>      | 5           | 4             | Controller hardware failure (phase/gain initialization) | Cycle power. If fault persists, replace controller.   |
| Reserved                    | 6           | 5             | Reserved  |   |
| CABLE Error                 | 7           | 6             | Cable NOVRAM linearization data invalid                 | At startup, the cable NOVRAM error will flash the LED until the controller receives a status command from host. |
| NOV2 Error                  | 8           | 7             | Controller NOVRAM linearization data invalid            | Replace sensor or perform a 25-point linearization. Contact Technical Support.                                  |
| Reserved                    | 9           | 8             | Reserved  |   |
| EEPROM Error <sup>2</sup>   | 10          | 9             | EEPROM is not working                                   | Reload program code.  |

| Self Test Condition | LED Flashes | Self Test Bit | Description                                  | What to do...  |
|---------------------|-------------|---------------|--|--|
| NOV5 Error          | 11          | 10            | Controller ID is not valid                   | Restore defaults. If fault persists, replace controller. |
| NOV6 Error          | 12          | 11            | Interface configuration values are not valid | Restore defaults. If fault persists, replace controller. |
| NOV7 Error          | 13          | 12            | Touch configuration values are not valid     | Restore defaults. If fault persists, replace controller. |
| Reserved            | 14          | 13            | Reserved                                     |  |
| Resistance Error    | 15          | 14            | Sensor resistance is out of supported range  | Cycle power. If fault persists, replace sensor.          |
| Backplane Error     | 16          | 15            | Low resistance path from backplane to sensor | Cycle power. If fault persists, replace sensor.          |
| Corner Error        | 17          | 16            | Corner drive offset level is too high        | Cycle power. If fault persists, replace controller.      |
| Fixed Cal Error     | 18          | 17            | Fixed 2-point cal error high                 | Cycle power. If fault persists, replace controller.      |

Note 1: this is a fatal error.

Note 2: this error is detected by the ROM code

Note 3: indicates that the EEPROM is not formatted when given by the ROM code

## Installing 3M™ MicroTouch™ Software

3M™ MicroTouch™ Software includes the driver that enables your sensor to work with your computer. 3M Touch Systems has touch drivers for many operating systems, including Windows® 7, Windows® Vista, Windows® XP, Windows® XP embedded, Windows® CE, and Linux® (Kernel 2.6) (refer to the website for a complete listing). You must be sure to install the correct software for your operating system.

3M™ MicroTouch™ Software includes a control panel for setting your sensor preferences and a diagnostic utility. If you are experiencing problems with the sensor, you can use the diagnostic utilities provided to locate the controller and test the sensor.

For more information on connecting your cables and installing and using the sensor control panel and utilities, refer to the 3M™ MicroTouch™ Software User Guides available on the corporate website at [www.3Mtouch.com](http://www.3Mtouch.com).

## CHAPTER 3

# 3M™ MicroTouch™ EX USB Controller Communications

This chapter discusses the fundamentals of communicating with the 3M™ MicroTouch™ EX USB controller. The firmware commands, which are usually issued by a driver or utility program on the host system, control the operation of the touch controller, however developers can enter these commands directly. This chapter:

- Describes the controller default settings.
- Lists the recommended firmware commands for current development.
- Describes how to use each of these commands.
- References additional commands developers may need to use.

The description of each command includes the command syntax, the default value, how the command works, and the expected response from the controller.

Note: HID versions of these controllers are available. Please consult your sales representative for details.

## Overview of USB Firmware Commands

Developers may use these USB commands when writing touch applications, developing custom drivers or touch configurations, or testing their touch systems. Developers can issue commands to initialize the controller, select operating modes, and execute diagnostic functions.

Most sensor users do *not* have to use firmware commands to use their touch systems. For example, users can use MT 7 software to calibrate the sensor or to determine the controller type and firmware version.

**Note:** This document assumes you are familiar with USB standards and modes of communication with USB devices, as well as firmware commands and how to use them. Executing some commands may alter the performance of your sensor and render it inoperable. You should be aware of the results before executing any firmware commands.

---

To optimize the performance of the 3M™ MicroTouch™ EX USB touch controller and simplify the development of custom drivers, 3M Touch Systems recommends you use the commands listed in this chapter for current development. Using these commands ensures compatibility with all 3M™ MicroTouch™ controllers.

## Communicating with the Controller

This section provides information on sending firmware commands to the controller and interpreting the responses that the controller returns. The default operation of the EX USB controller is USB Rev 1.1 compliant.

The USB command set is implemented by using vendor requests and vendor reports, i.e., vendor specific transactions.

You need to know product ID (1 for normal mode and 2 for special mode) and the vendor ID (0596H) to write your own driver.

The EX USB controller is command set compatible with previous generation MicroTouch™ USB controllers. Modifications of existing software should not be necessary when replacing an older controller.

The following commands are those that 3M Touch Systems currently uses for communications. 3M Touch Systems recommends that you use only these commands for 3M™ MicroTouch™ EX USB controller communications.

## Vendor Requests

The following list summarizes the six available vendor requests:

- Request 4                      Calibrate
- Request 6                      Status
- Request 7                      Reset
- Request 8                      Restore Defaults
- Request 10                     Controller ID
- Request 16                     Read Parameter



## Sending Commands to the Controller

**Table 5. General Format for Vendor Requests**

| Offset | Field         | Size | Value    | Description  |
|--------|---------------|------|----------|--|
| 0      | bmRequestType | 1    | d1000000 | Characteristics of request [dir, type, recipient]<br>D7: Data Transfer Direction<br>0 = Host-to-device<br>1 = Device-to-host<br>D6... 5 Type<br>0 = Standard<br>1 = Class<br>2 = Vendor<br>3 = Reserved<br>D4...0 Recipient<br>0 = Device<br>1 = Interface<br>2 = Endpoint<br>3 = Other<br>4...31 = Reserved |
| 1      | bRequest      | 1    | 0xXX     | Specific request [our command number]  |
| 2      | wValue        | 2    | 0xFFFF   | Used to specify command parameters   |
| 4      | wIndex        | 2    | 0xFFFF   | Used to specify command parameters   |
| 6      | wLength       | 2    | 0xFFFF   | Number of bytes to transfer  |

The Type field should be set to Vendor (0x10). The Recipient field should be set to Device. The Direction field depends on the command.

## Receiving Reports from the Controller

Four reports can be sent from the controller to the host. These reports fit into two categories: those sent immediately in response to a host request (synchronous) and those sent when updates to the data they contain become available (asynchronous).

### Synchronous reports:

- Report 4                      Parameter Data
- Report 6                      Status
- Report 12                      Controller ID

### Asynchronous reports:

- Report 1                      Coordinate Data

Some possible reasons for a command failure include:

- The command was not formatted correctly.
- The system parameters were not set up to allow command execution.
- The controller does not support the command.

## Controller Initialization

To initialize the EX USB controller, 3M Touch Systems recommends that the host system issue a Reset command whenever the host system is powered on and is attempting to establish communication with the controller.

## Coordinate Data Report 1

Coordinate Data Report 1 is used to transfer both the raw and adjusted coordinate data to the host. This report, when activated, is sent to the host whenever new data is available. It is an asynchronous report activated by default at power up.

**Table 6. Coordinate Data Report**

| Offset | Field         | Size | Value  | Description              |
|--------|---------------|------|--------|--------------------------|
| 0      | Report ID     | 1    | 0x01   | USB report ID number     |
| 1      | Loop Counter  | 1    | 0xXX   | Report synchronization   |
| 2      | Status byte   | 1    | 0xXX   | Pen/finger touch status  |
| 3      | X Compensated | 2    | 0xFFFF | Compensated X coordinate |
| 5      | Y Compensated | 2    | 0xFFFF | Compensated Y coordinate |
| 7      | X Raw         | 2    | 0xFFFF | Raw X coordinate         |
| 9      | Y Raw         | 2    | 0xFFFF | Raw Y coordinate         |

The main purpose of the loop counter is to effectively put a time stamp on the output data. Data produced in the same tick will have the same timestamp. This can be used to match the final coordinate data with other data that was used to produce it. This is not a sequential number.

The status byte contains information pertaining to whether the sensor is being touched.

**Table 7. Touch Status**

| Bit | Description   |
|-----|---|
| 7   | Always 1  |
| 6   | Proximity<br>1 when touching<br>0 when not touching |
| 5   | Reserved  |
| 4   | Reserved  |
| 3   | Reserved  |
| 2   | Reserved  |
| 1   | Reserved  |
| 0   | Reserved  |

The raw X and Y coordinate data are generated directly from the sensor. The range of values is -8192 to 8191. The X and Y adjusted coordinate data is derived by applying calibration information. The range of values is 0 to 65,535. Coordinate data is sent LSB first.

## Operating Mode

The operating mode specifies the conditions under which the controller sends the X and Y touch coordinates (input data packet) to the host system.

Report 1 enabled is the default operating mode for the EX USB controller. In Report 1, the controller sends a continuous stream of data packets when the sensor is touched. The controller sends the data as long as a touch continues on the sensor.

Because Report 1 sends touch data continually, it is the most versatile mode, and it provides the best response time and overall feel.

3M Touch Systems recommends that the touch driver generate an event as each packet in the data stream arrives. Because touchdown and liftoff events are specially coded, your software can generate mouse events that correspond to what the user is doing.

## Calibration Request 4

This is a request to perform a 2-point calibration. The calibration can be performed at points inset from the lower left and upper right corners (extended calibration) or it can be done at those corners. This is equivalent to the Calibrate Extended (12.5% insets from the lower left and upper right corners) command used by 3M™ MicroTouch™ serial controllers. The 2-point calibration defines the active area of the sensor by mapping two targets displayed on the video image to absolute X and Y coordinates on the sensor.

**Table 8. Calibration Request**

| Offset | Field         | Size | Value    | Description      |
|--------|---------------|------|----------|------------------|
| 0      | bmRequestType | 1    | 01000000 | Characteristics  |
| 1      | bRequest      | 1    | 4        | Command number   |
| 2      | wValue        | 2    | 0xXXXX   | Calibration type |
| 4      | wIndex        | 2    | 0x0000   | Not used         |
| 6      | wLength       | 2    | 0        | No data phase    |

The direction bit in bmRequestType has been set to 0 (host-to-device). This request does not require that the device return any data. The byte bRequest is set to 4 to indicate that this is the calibration command.

The wValue field is used to select the type of calibration to be performed. This value can be either 1 for Extended (or Inset) or 2 for Corner.

The controller does not use the wIndex field. This field should be set to zero to ensure future compatibility.

## Response

The device stalls endpoint 0 if the request cannot be processed successfully. The host should issue status requests to determine the status of this request. A command status of 1 indicates that the controller is waiting for a touch in the lower left quadrant. A status of 2 indicates that the lower left touch has been completed and the controller is waiting for a touch in the upper right quadrant. A status of 3 indicates that the upper right touch has been completed. A status of 0 indicates that the request has failed. A soft reset command should be sent if the host wishes to terminate calibration.

## Determining Target Areas

The default calibration targets (points) are located 12.5% (1/8) inward from the corners of the video image. For example, suppose the resolution of your Windows-based display is 1024 x 768. The Calibrate Extended command calculates the amount to move inward as follows:

- Amount to move inward in the X direction:  $1024 \times 1/8 = 128$
- Amount to move inward in the Y direction:  $768 \times 1/8 = 96$

The Calibrate Extended command then positions the first calibration target inward from the lower left corner (0,767) and the second calibration target inward from the upper right corner (1023,0). The following illustration shows how the calibration targets are calculated for a Windows-based system. Your operating system may be different.

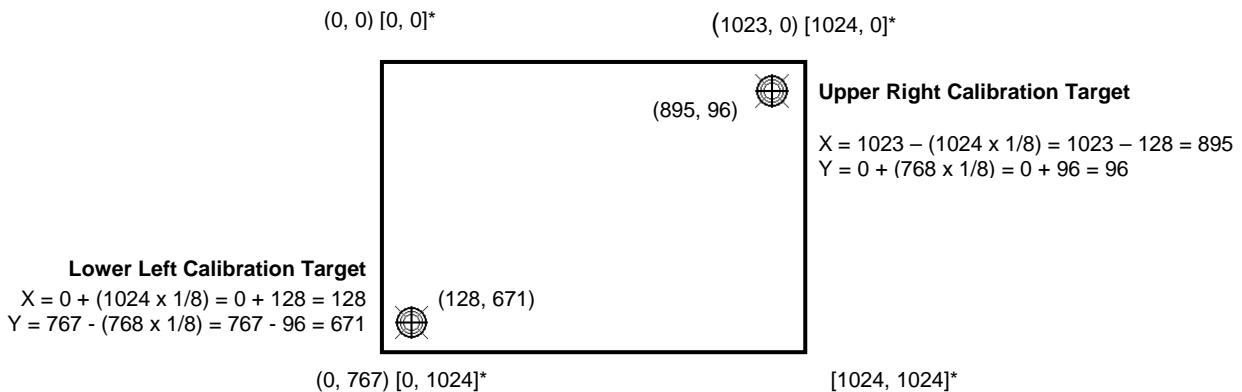

\*The coordinates are in *video* terms, with the origin (0, 0) in the upper left corner of the sensor. Examples from the *controller's* perspective, however, place the origin at the lower left corner of the sensor (numbers in brackets). The controller outputs 0 to 64K on both axes independent of display screen resolution.

## Controller Status Request 6

This is a request to send information that indicates the status of the controller. Use this request to determine whether there were any power on check errors and whether the last request was completed successfully.

The Controller Status Request is used to poll the controller for command completion when a previous USB request involved a controller reset. Refer to the Reset Request 7 for additional details.

**Table 9. Controller Status Request**

| Offset | Field         | Size | Value    | Description           |
|--------|---------------|------|----------|-----------------------|
| 0      | bmRequestType | 1    | 11000000 | Characteristics       |
| 1      | bRequest      | 1    | 6        | Command number        |
| 2      | wValue        | 2    | 0x0000   | Not used              |
| 4      | wIndex        | 2    | 0x0000   | Not used              |
| 6      | wLength       | 2    | 0xFFFF   | Size of status report |

The direction bit in bmRequestType has been set to 1 (device-to-host) to return the status report.

The byte bRequest is set to 6 to indicate that this is a Controller Status request.

The controller does not use the wValue and wIndex fields. These fields should be set to zero to ensure future compatibility.

The wLength field indicates the size of the Controller Status report.

## Response

When the request is processed, the device returns a Controller Status report.

The device stalls endpoint 0 if the request cannot be processed successfully. This would happen if the report length requested by wLength does not match the controller status report size.

## Controller Status Report 6

This report contains information describing the status of the controller. The report sent is determined by the size specified in the wLength field of the Status Request.

All multi-byte quantities in this report are sent LSB first.

### Standard Format Status Report

This version of the Status report will be sent if the EX compatible driver asks for the 8-byte Status report. This version is simply the first 8 bytes of the controller Status report.

### EX Controller Status Report

This version of the Status report is only compatible with the EX USB controller. This version is sent when the larger (20-byte) Status report is requested.

**Table 10. Expanded Status Report**

| Offset | Field     | Size | Value | Description      |
|--------|-----------|------|-------|------------------|
| 0      | Report ID | 1    | 0x06  | Report ID number |

| Offset | Field               | Size | Value   | Description                      |
|--------|---------------------|------|---------|----------------------------------|
| 1      | POC Status          | 2    | 0XXXXX  | Power On Check Status            |
| 3      | Cmd Status          | 1    | 0XX     | Status of last command           |
| 4      | Touch Status        | 1    | 0XX     | Finger Up/Down                   |
| 5      | Asynch Reports      | 2    | 0XXXXX  | Active asynchronous reports      |
| 7      | Reserved            | 2    | 0XXXXX  | Reserved                         |
| 9      | Extended POC Status | 2    | 0XXXXX  | Additional Power On Check Status |
| 11     | Reserved            | 9    | 9 bytes | Reserved                         |

POC Status – The status of the Power On Checks. Various controller systems are checked at power-up. If any failures in these systems are detected, a POC flag is set. The POC status field reports the state of these flags. The POC status information is also flashed on the controller’s LED. The number of flashes generated for a given error is one more than the error’s bit number. Refer to Table 3 for further details. This is a 2-byte bitmapped field.

**Note:** Issuing a Status Request will suppress displaying the cable NOVRAM error (bit 6) on the LED. Even though the error is suppressed, it will continue to flash on the LED until the sensor is touched.

Cmd Status – The status for the last command request. This field is used to determine whether the last request was processed successfully. It is also used to track the progress of a multi-stage request, such as 2-point calibration. The Status Request does not affect the contents of this field, i.e., successful or unsuccessful processing of a previous status request does not cause the command status field to be updated.

**Table 11. Valid Command Status Field Entries**

| Response | Description  |
|----------|--|
| 0        | Failure in command processing                          |
| 1        | Command being processed                                |
| 2        | Stage 1 processing complete (for multi-stage commands) |
| 3        | Command complete                                       |
| 4        | Soft reset occurred                                    |
| 5        | Hard reset occurred                                    |

Touch Status – Status information for the most recent touch coordinate.

**Table 12. Touch Status**

| Bit Number | Description                      |
|------------|----------------------------------|
| 0          | 1 if the sensor is being touched |
| 1 - 7      | Reserved                         |

Asynch reports – the only active asynchronous report is the Touch Coordinate report 1.

Extended POC Status – This is additional power on status information. This is a 2-byte bitmapped field.

**Table 13. Extended POC Status**

| Bit Number | Description                           |
|------------|---------------------------------------|
| 0          | Corner drive offset level is too high |
| 1          | Fixed 2-point calibration error high  |
| 2 - 15     | Reserved                              |

## Reset Request 7

This is a request to perform a controller reset. The standard hard or soft reset can be requested. Soft resets are generally required for any parameter changes to take effect. A soft reset results in the touch application using its initial (start-up) values.

**Table 14. Reset Request**

| Offset | Field         | Size | Value    | Description     |
|--------|---------------|------|----------|-----------------|
| 0      | bmRequestType | 1    | 01000000 | Characteristics |
| 1      | bRequest      | 1    | 7        | Command number  |
| 2      | wValue        | 2    | 0xXXXX   | Reset type      |
| 4      | wIndex        | 2    | 0x0000   | Not used        |
| 6      | wLength       | 2    | 0x0000   | No data phase   |

The direction bit in bmRequestType has been set to 0 (host-to-device).

The byte bRequest is set to 7 to indicate that this is a Reset request.

The wValue field is used to select the type of reset to be performed -- 1 for Soft Reset and 2 for Hard Reset.

The wIndex field is not used. This field should be set to zero to ensure future compatibility.

The wLength field is set to zero since there is no data phase for this request.

## Response

Since the time to complete the soft reset can be more than 500 ms, the device acknowledges the request before it is completed. The host must issue a status request to determine whether the reset request was completed. The command status field of the status report will be set to “command in progress” while the soft reset is occurring. The field will change to “soft reset occurred” when the reset has completed. Any other request issued while the reset is still in progress will be ignored.

The hard reset is executed immediately upon decoding of this request. The reset sequence begins by simulating a device disconnect from the host. A re-connect is then performed and the device must re-enumerate its connection with the host. Because of this, a response to the request cannot be sent prior to, or even after, the beginning of the reset sequence.

The host should issue status and ID requests after the reset has completed to verify whether this request was handled properly by the device. The status request should be used to determine when the hard reset occurred. The ID request is used to verify that the controller is now in the desired mode by looking at the contents of the controller type field.

The device stalls endpoint 0 if the request cannot be processed successfully. The request cannot be processed if the reset type specified by the wValue field is not valid.

### EX Controller Compatibility Issues

The hard reset did not use a device disconnect as part of the reset process for the previous 3M™ MicroTouch™ USB controller. The disconnect causes the driver to unload and will result in any handles to the driver that an application may have becoming invalid. An application should handle an unplug event.

## Restore Defaults Request 8

This is a request to restore the default values in the controller. This is used to restore the values to the factory presets.

A soft reset is automatically done after completing the request so that parameter changes will take effect.

**Table 15. Restore Defaults Request**

| Offset | Field         | Size | Value    | Description     |
|--------|---------------|------|----------|-----------------|
| 0      | bmRequestType | 1    | 01000000 | Characteristics |
| 1      | bRequest      | 1    | 8        | Command number  |
| 2      | wValue        | 2    | 0x0000   | Reserved        |
| 4      | wIndex        | 2    | 0x0000   | Reserved        |
| 6      | wLength       | 2    | 0x0000   | No data phase   |

The direction bit in bmRequestType has been set to 0 (host-to-device). This request does not require that the device return any data.

The byte bRequest is set to 8 to indicate that this is the Restore Defaults request.

The wValue field should be set to 0 for future compatibility.

The wIndex field should be set to 0 for future compatibility.

### Response

The device stalls endpoint zero if it cannot process this request. The request will fail if any of the fields are not set correctly.



When the request is processed successfully, a positive USB acknowledge (zero length data packet) is sent.

A soft reset will be done at the completion of this request. Because of this, the controller must be polled to determine when the reset is done (see Reset Request for details).

## Controller ID Request 10

This is a request to send various pieces of information that identify the controller, including the controller type and firmware revision level. The key use for this request is in identifying the mode that the controller is running in and the revision level of the ASIC firmware.

**Table 16. Controller ID Request**

| Offset | Field         | Size | Value    | Description         |
|--------|---------------|------|----------|---------------------|
| 0      | bmRequestType | 1    | 11000000 | Characteristics     |
| 1      | bRequest      | 1    | 10       | Command number      |
| 2      | wValue        | 2    | 0x0000   | Not used            |
| 4      | wIndex        | 2    | 0x0000   | Not used            |
| 6      | wLength       | 2    | 0xFFFF   | Length of ID report |

The direction bit in bmRequestType has been set to 1 (device-to-host) to return the Controller ID report.

The byte bRequest is set to 10 to indicate that this is Controller ID request.

This request does not use the wValue or wIndex fields. These fields should be set to zero to ensure future compatibility.

The wLength field is set to the size (either 18 or 24 bytes) of a Controller ID report.

### Response

The controller sends the Controller ID report when the request is processed successfully.

If the request cannot be processed, endpoint 0 will be stalled. The request cannot be processed if the requested report size (wLength) does not match either the size of the backward compatible ID report (18) or the EX report (24).

## Controller ID Report 12

This report contains information describing the controller, including its type, firmware revision, special features, and the ROM checksum. This report is sent via the control endpoint.

All multi-byte quantities in this report are sent LSB first.

## Standard Format Controller ID Report

This version of the Controller ID report will be sent if the EX compatible driver asks for the 16-byte Controller ID report size. This version contains the first 16 bytes of the EX Controller ID report.

## EX Controller ID Report

This version of the Controller ID report is only compatible with the EX USB driver. This version is sent when the larger (24-byte) Controller ID report is requested.

**Table 17. Expanded Controller ID Report**

| Offset | Field              | Size | Value      | Description                             |
|--------|--------------------|------|------------|---|
| 0      | Report ID          | 1    | 0x0C       | Report ID number                        |
| 1      | Controller type    | 2    | 0XXXXX     | Indicates the type of controller        |
| 3      | FW major revision  | 1    | 0xXX       | Firmware major revision level           |
| 4      | FW minor revision  | 1    | 0xXX       | Firmware minor revision level           |
| 5      | Features           | 1    | 0xXX       | Special features                        |
| 6      | Constants Checksum | 2    | 0XXXXX     | RAM constants checksum                  |
| 8      | Max Param Write    | 2    | 0xFFFF     | Maximum data for Read Parameter request |
| 10     | Reserved           | 1    | 0x41       | Reserved                                |
| 11     | Reserved           | 1    | 0x41       | Reserved                                |
| 12     | Reserved           | 1    | 0x41       | Reserved                                |
| 13     | Reserved           | 1    | 0x41       | Reserved                                |
| 14     | Reserved           | 1    | 0x41       | Reserved                                |
| 15     | Reserved           | 1    | 0x42       | Reserved                                |
| 16     | Reserved           | 1    | 0x41       | Reserved                                |
| 17     | Reserved           | 1    | 0x41       | Reserved                                |
| 18     | Code Checksum      | 4    | 0XXXXXXXXX | RAM Program Code checksum               |
| 22     | ASIC type          | 2    | 0x01XX     | ASIC type                               |

Controller Type – The identifier M1 is used. M identifies it as an EX based USB controller. The 1 identifies it as the first model of this type. This value is treated as an integer, not two characters. This means that the 1 will be transmitted first.

**Note:** If you received an identifier of M0, you must issue a Reset with a wValue of 5. This must be done twice to lock in the values.

FW Major Revision – This can range from 0 to 99. This is a BCD value, i.e., major revision 23 is sent as 0x23.

FW Minor Revision – This can range from 0 to 99. This is a BCD value, i.e., minor revision 23 is sent as 0x23.

Features – This identifies the special features of the controller. This is a bitmapped field.

Constants Checksum – 2-byte checksum for the constants data section.

Max Parameter Write -- The largest transfer that can take place. This only affects the Read Parameter requests.

Code Checksum – 4-byte checksum for the program section of the code.

ASIC Type – this indicates the type and version of the ASIC in the controller. The value 0x0100 indicates the first EX revision. The high byte is used to note major ASIC changes, such as a new ASIC family, and the low byte indicates changes within a family.

## Read Parameter Request 16

This is a request to send the contents of a parameter via the control endpoint. This is a one-time transfer of data. The request is used to access data in the controller.

This request provides a means for reading the configuration parameters. The request uses parameter numbers to determine what data is being requested and where that data is located.

**Table 18. Read Parameter Request**

| Offset | Field         | Size | Value    | Description                     |
|--------|---------------|------|----------|---------------------------------|
| 0      | bmRequestType | 1    | 11000000 | Characteristics                 |
| 1      | bRequest      | 1    | 16       | Command number                  |
| 2      | wValue        | 2    | 0xXXXX   | Parameter number                |
| 4      | wIndex        | 2    | 0x0000   | Not used                        |
| 6      | wLength       | 2    | 0xXXXX   | Length of Parameter Data report |

The direction bit in bmRequestType has been set to 1 (device-to-host) to return the contents of the requested parameter.

The byte bRequest is set to 16 to indicate that this is the Read Parameter request.

The wValue field is set to the number of the parameter being requested.

This request does not use the wIndex field. This field should be set to zero to ensure future compatibility.

The wLength field is the number of bytes being sent by the device to the host. The data is returned to the host in the format of the Parameter Data report, which has a 3-byte header, so 3 must be added to the number of parameter bytes desired. The following table lists the parameters currently supported and the appropriate settings for the request fields.

**Table 19. Supported Parameters**

| Parameter (wValue) | wIndex | wLength (bytes+3) | Range | Description   |
|--------------------|--------|-------------------|-------|---|
| 0                  | 0      | 0                 | 0     | Reserved for future use   |
| 1                  | 0      | 5                 | 0 – 3 | Sensor orientation - where the lower left corner of the display maps to the sensor. |

|   |   |   |                  |   |
|---|---|---|------------------|---|
|   |   |   |                  | 0000 – Upper right                        |
|   |   |   |                  | 0001 – Lower right                        |
|   |   |   |                  | 0002 – Upper left                         |
|   |   |   |                  | 0003 – Lower left (standard, not rotated) |
| 2 | 0 | 7 | $0 - 2^{32} - 1$ | Controller serial number                  |

## Response

The parameter data is sent to the host in a Parameter Data report. All parameter data is treated as if it were stored as bytes. This means that multi-byte values will be sent MSB first.

If the command cannot be processed, the device stalls endpoint 0. The command cannot be processed if the parameter number is not valid. It cannot be processed if less than 4 bytes (wLength) are requested. It cannot be processed if more data is requested than is contained in the parameter.

## Parameter Data Report 4

This report is sent in response to any request for parameter data. All parameter data is treated as if it were stored as bytes in the order that it is stored in memory. This means that multi-byte values will be sent MSB first.

**Table 20. Parameter Data Report**

| Offset | Field      | Size      | Value  | Description              |
|--------|------------|-----------|--------|--------------------------|
| 0      | Report ID  | 1         | 0x04   | Report ID number         |
| 1      | Data size  | 2         | 0XXXXX | Amount of data to follow |
| 3      | Data bytes | Data Size | 0XXX   | Data bytes               |

Data size – the number of data bytes to follow.

Data byte – At least 1 data byte will follow when data size is greater than zero. The number of data bytes returned by this report is limited by the “Max Param Write” value returned by the Controller ID report. The contents of this data section are dependent on which parameter is being accessed.

## APPENDIX A

# EX121/EX141 Controller Specifications

This section provides controller specifications such as power requirements, environmental requirements, and cable connectors.

The EX121/EX141 controller is a compact (3.5 x 2.25 x 0.3 inches), USB controller. This controller can be internally mounted in your display, or enclosed in a molded plastic case (3.75 x 2.5 x 0.9 inches) and mounted to the back or side of your display.

### EX121/EX141 Dimensions

The controller has a NOVRAM sensor connector and a USB cable connector and comes in two varieties:

1. The cased version measures 2.5 x 3.75 inches with a total height of approximately 1-inch with the sensor cable attached. The cased version comes with a Type-A USB cable.
2. The uncased version measures 2.25 x 3.6 inches with a total height profile of 0.5-inch from the thru hole pins on the trace side of the board to the top of the highest component on the opposite side.

The following figures show the overall dimensions of the EX121/EX141 controller and the locations of the mounting holes and connectors.

**Figure 1 EX121 Dimensions**



**Figure 2 EX141 Dimensions**



## Technical Specifications

The controller specifications listed below were validated in test systems containing 3M Touch Systems components. These specifications may not be valid if configured with components from suppliers other than 3M Touch Systems. All components in the manufacture of electronic controllers are RoHS Directive compliant (2011/65/EU).

### Physical Dimensions

|         |                                |                               |
|---------|--------------------------------|-------------------------------|
| Uncased | 3.50 in. x 2.30 in. x 0.45 in. | (88.9 mm x 58.4 mm x 11.4 mm) |
| Cased   | 3.75 in. x 2.50 in. x 0.90 in. | (95.3 mm x 63.5 mm x 22.9 mm) |

### Board Level Functions

|       |   |
|-------|---|
| Power | 5 VDC (87 mA typical, 100 mA maximum); ± 5% regulation 50 mV <sub>pp</sub> maximum ripple and noise |
|-------|---|

### Regulatory Requirements

|  |         |                              |
|--|---------|------------------------------|
| CE   |         | Compliant                    |
| Radiated Emissions – EN 55022:1998                     | Class B | Compliant                    |
| AC Mains Conducted Emissions – EN 55022:1998           | Class B | Compliant                    |
| Telco Lines Conducted Emissions                        | N/A     | N/A                          |
| RFI – EN 61000-4-3 / ENV 50140                         | Class A | Compliant                    |
| CRFI – EN 61000-4-6                                    | N/A     | Cable < 3 meters long<br>N/A |
|  | Class A | < 80% Screen Area            |
|  | Class B | ≥ 80% Screen Area            |
| EFT (Burst Immunity) – EN 61000-4-4                    | Class B | Compliant                    |
| ESD Susceptibility – IEC 61000-4-2                     | Class 1 | Compliant                    |
| Surge – EN 61000-4-5                                   | Class B | Compliant                    |
| Harmonics – EN 61000-3-2                               | Class A | Compliant                    |
| Flicker – EN 61000-3-3                                 |         | Compliant                    |
| Power Frequency Magnetic Field – EN 61000-4-8          | N/A     | N/A                          |
| Voltage Dips – EN 61000-4-11                           | Class B | < 5% V                       |
|  | Class C | < 70% V                      |
| Voltage Interruptions – EN 61000-4-11                  | Class C | Compliant                    |
| FCC Class B / CISPR22 Class B                          | Class B | Compliant                    |
| VCCI Class B ITE Emissions (Japan)                     | Class B | Compliant                    |
| AS/NZS 3548:1995/CISPR 22 Class B ITE Emissions (Aus.) | Class B | Compliant                    |
| UL/cUL   |         | Compliant                    |

## Ambient Operating and Storage Environmental Conditions

**Note:** All humidity is non-condensing

|                             |                  |                             |
|-----------------------------|------------------|-----------------------------|
| Operating Temperature Range |                  | -40 °C to +70 °C            |
| Operating Humidity Range    | < 36° C 0-90% RH | ≥ 36 °C (refer to Figure 4) |
| Storage Temperature Range   |                  | -50 °C to +85 °C            |
| Storage Humidity Range      | < 36°C 0-90% RH  | ≥ 36 °C (refer to Figure 4) |

## Performance and Reliability

|  |  |                     |
|--|--|---------------------|
| Minimum Touch Duration   |  | Typically 5.4 msec. |
| Touch Resolution – (Maximum addressable coordinates generated by the controller) |  | 16K x 16K           |
| ESD Susceptibility <sup>1</sup> -  |  |                     |
| ±8 kV Contact Discharge – Class 2 per section 9 of IEC 61000-4-2                 |  | Compliant           |
| 1 false touch allowed  |  |                     |
| ±27 kV Air Discharge – Class 1 per section 9 of IEC 61000-4-2                    |  | Compliant           |
| Normal Operation – No false touches  |  |                     |
| MTBF (by MIL Std. 217F Calculation)  |  | 500,000 Hours       |

## Touch System Parameters

|  |  |                                       |
|--|--|---------------------------------------|
| Accuracy vs. Dynamic Temperature Change<br>(Tested at 0 deg. C to 60 deg. C with a 0.5 deg. C/minute temperature ramp) |  | Maintains 99.0% Accuracy              |
| Sensor Compatibility Sensors   |  | 3M™ MicroTouch™<br>Surface Capacitive |
| Communications Protocol  |  | USB                                   |

<sup>1</sup> ESD discharges to a 3M Touch Systems sensor connected to the controller



## APPENDIX B

# EX111/EX151 Controller Specifications

This section provides controller specifications such as power requirements, environmental requirements, and cable connectors. The EX111/EX151 controller is a compact USB controller. This controller can be internally mounted in your display.

The following figures show the overall dimensions of the EX111/EX151 controller and the locations of the mounting holes and connectors.

The EX111/EX151 has a sensor connector (JP2) and a USB cable connector (JP1) as shown below. The uncased controller measures approximately 1.3 x 2.6 inches with a total height of approximately 0.38-inch from the thru hole pins on the trace side of the board to the top of the highest component on the opposite side.

**Figure 3 EX111 Dimensions**

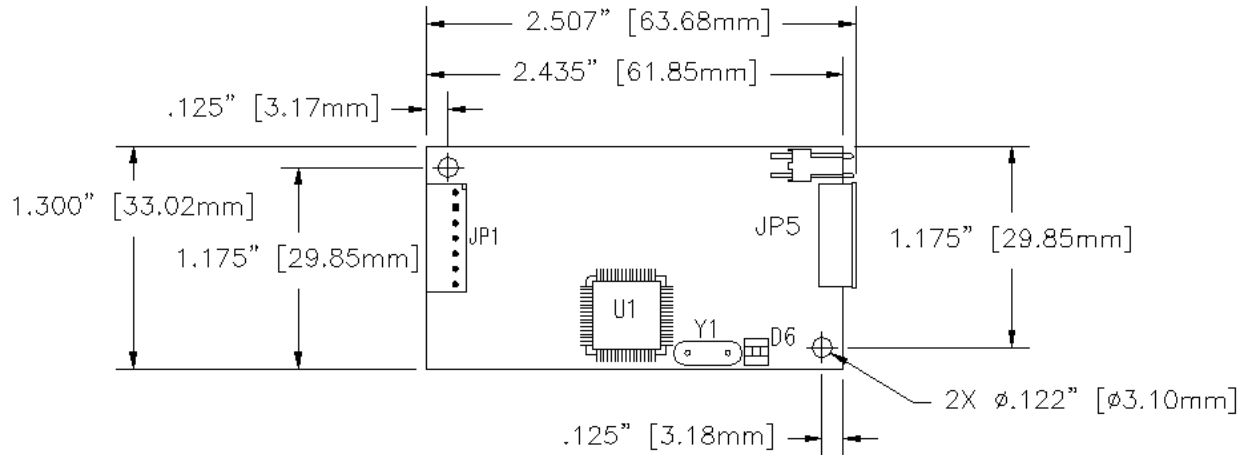

**Figure 4 EX151 Dimensions**

## Technical Specifications

The controller specifications listed below were validated in test systems containing 3M Touch Systems components. These specifications may not be valid if configured with components from suppliers other than 3M Touch Systems. All components in the manufacture of electronic controllers are RoHS Directive compliant (2011/65/EU).

### Physical Dimensions

2.55 in. x 1.30 in. x 0.45 in. (65.0 mm x 33.0 mm x 11.4 mm)

### Board Level Functions

Power 5 VDC (75 mA typical, 100 mA maximum);  $\pm 5\%$  regulation  
50 mV<sub>pp</sub> maximum ripple and noise

### Regulatory Requirements

|  |         |                         |           |
|--|---------|-------------------------|-----------|
| CE   |         |                         | Compliant |
| Radiated Emissions – EN 55022:1998           | Class B |                         | Compliant |
| AC Mains Conducted Emissions – EN 55022:1998 | Class B |                         | Compliant |
| Telco Lines Conducted Emissions              | N/A     |                         | N/A       |
| RFI – EN 61000-4-3 / ENV 50140               | Class A |                         | Compliant |
| CRFI – EN 61000-4-6                          | N/A     | Cable < 3 meters long   | N/A       |
|  | Class A | < 80% Screen Area       |           |
|  | Class B | $\geq 80\%$ Screen Area |           |

|  |         |         |           |
|--|---------|---------|-----------|
| EFT (Burst Immunity) – EN 61000-4-4                    | Class B |         | Compliant |
| ESD Susceptibility – IEC 61000-4-2                     | Class 1 |         | Compliant |
| Surge – EN 61000-4-5                                   | Class B |         | Compliant |
| Harmonics – EN 61000-3-2                               | Class A |         | Compliant |
| Flicker – EN 61000-3-3                                 |         |         | Compliant |
| Power Frequency Magnetic Field – EN 61000-4-8          | N/A     | N/A     |           |
| Voltage Dips – EN 61000-4-11                           | Class B | < 5% V  |           |
|  | Class C | < 70% V | Compliant |
| Voltage Interruptions – EN 61000-4-11                  | Class C |         | Compliant |
| FCC Class B / CISPR22 Class B                          | Class B |         | Compliant |
| VCCI Class B ITE Emissions (Japan)                     | Class B |         | Compliant |
| AS/NZS 3548:1995/CISPR 22 Class B ITE Emissions (Aus.) | Class B |         | Compliant |
| UL/cUL   |         |         | Compliant |

## Ambient Operating and Storage Environmental Conditions

**Note:** All humidity is non-condensing

|                             |                 |                             |
|-----------------------------|-----------------|-----------------------------|
| Operating Temperature Range |                 | -40 °C to +70 °C            |
| Operating Humidity Range    | <36° C 0-90% RH | ≥ 36 °C (refer to Figure 4) |
| Storage Temperature Range   |                 | - 50 °C to +85 °C           |
| Storage Humidity Range      | < 36°C 0-90% RH | ≥ 36 °C (refer to Figure 4) |

## Performance and Reliability

|  |                     |
|--|---------------------|
| Minimum Touch Duration   | Typically 5.4 msec. |
| Touch Resolution – (Maximum addressable coordinates generated by the controller) | 16K x 16K           |

ESD Susceptibility<sup>1</sup> -

<sup>1</sup> ESD discharges to a 3M Touch Systems sensor connected to the controller

|  |               |
|--|---------------|
| ±8 kV Contact Discharge – Class 2 per section 9 of IEC 61000-4-2<br>1 false touch allowed            | Compliant     |
| ±27 kV Air Discharge – Class 1 per section 9 of IEC 61000-4-2<br>Normal Operation – No false touches | Compliant     |
| MTBF (by MIL Std. 217F Calculation)  | 760,000 Hours |

## Touch System Parameters

|  |                                    |
|--|------------------------------------|
| Accuracy vs. Dynamic Temperature Change<br>(tested at 0 deg. C to 60 deg. C with a 0.5 deg. C/minute temperature ramp) | Maintains 99.0% Accuracy           |
| Sensor Compatibility   | 3M™ MicroTouch™ Capacitive Sensors |
| Communications Protocol  | USB                                |

**Figure 4 Storage and Operating Temperature with Humidity Conditions**

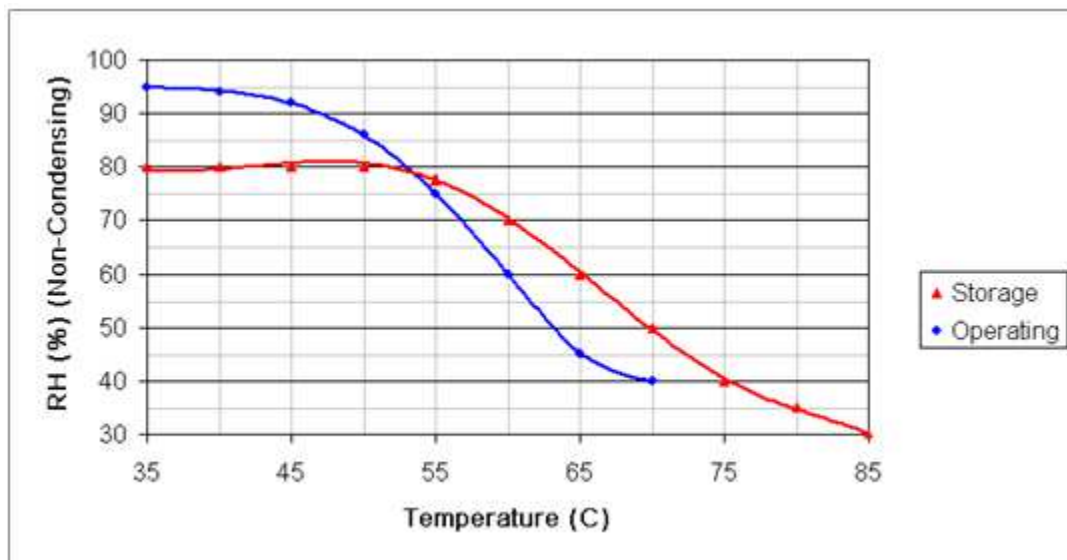

Компания «Life Electronics» занимается поставками электронных компонентов импортного и отечественного производства от производителей и со складов крупных дистрибьюторов Европы, Америки и Азии.

С конца 2013 года компания активно расширяет линейку поставок компонентов по направлению коаксиальный кабель, кварцевые генераторы и конденсаторы (керамические, пленочные, электролитические), за счёт заключения дистрибьюторских договоров

Мы предлагаем:

- Конкуренеспособные цены и скидки постоянным клиентам.
- Специальные условия для постоянных клиентов.
- Подбор аналогов.
- Поставку компонентов в любых объемах, удовлетворяющих вашим потребностям.
- Приемлемые сроки поставки, возможна ускоренная поставка.
- Доставку товара в любую точку России и стран СНГ.
- Комплексную поставку.
- Работу по проектам и поставку образцов.
- Формирование склада под заказчика.
- Сертификаты соответствия на поставляемую продукцию (по желанию клиента).
- Тестирование поставляемой продукции.
- Поставку компонентов, требующих военную и космическую приемку.
- Входной контроль качества.
- Наличие сертификата ISO.

В составе нашей компании организован Конструкторский отдел, призванный помогать разработчикам, и инженерам.

Конструкторский отдел помогает осуществить:

- Регистрацию проекта у производителя компонентов.
- Техническую поддержку проекта.
- Защиту от снятия компонента с производства.
- Оценку стоимости проекта по компонентам.
- Изготовление тестовой платы монтаж и пусконаладочные работы.



Тел: +7 (812) 336 43 04 (многоканальный)  
Email: [org@lifeelectronics.ru](mailto:org@lifeelectronics.ru)