

## Features

- Low Voltage Operation: 2.5 V
- Low Insertion Loss: 0.3 dB at 1 GHz
- Isolation: 34 dB @ 2.4 GHz
- 0.5 micron GaAs PHEMT Process
- Lead-Free 1.2 x 1.5 mm 6-Lead PQFN Package
- 100% Matte Tin Plating over Copper
- Halogen-Free "Green" Mold Compound
- RoHS Compliant\* and 260°C Reflow Compatible

## Description

M/A-COM's MASWSS0167 is a GaAs PHEMT MMIC single pole double throw (SPDT) switch in a lead-free 1.2 x 1.5 mm 6-lead PQFN package. The MASWSS0167 is ideally suited for applications where low control voltage, low insertion loss, moderate isolation, small size and low cost are required.

Typical applications are for filter and antenna switching in wireless LAN systems that connect separate receive functions to a common antenna, as well as other handset and general purpose switching applications.

The MASWSS0167 is fabricated using a 0.5 micron gate length GaAs PHEMT process. The process features full passivation for performance and reliability.

## Ordering Information<sup>1</sup>

Part Number	Package
MASWSS0167TR-3000	3000 piece reel
MASWSS0167SMB	Sample Test Board

1. Reference Application Note M513 for reel size information.

## Functional Schematic

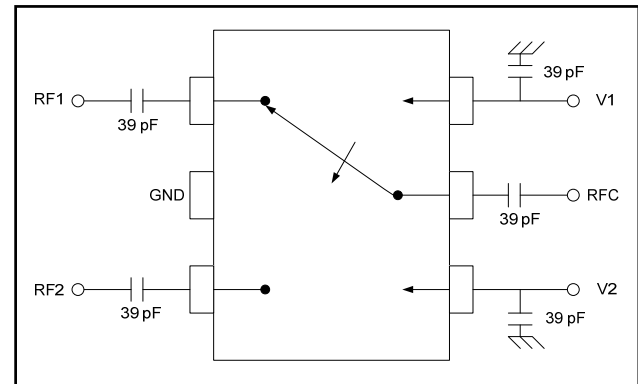

## Pin Configuration

Pin No.	Pin Name	Description
1	RF1	RF In/Out
2	GND	RF Ground
3	RF2	RF In/Out
4	V2	Control 2
5	RFC	RF Common
6	V1	Control 1

## Absolute Maximum Ratings<sup>2,3</sup>

Parameter	Absolute Maximum
Input Power (0.5 - 3 GHz, 2.5 V Control)	+32 dBm
Operating Voltage	+8.5 volts
Operating Temperature	-40°C to +85°C
Storage Temperature	-65°C to +150°C

2. Exceeding any one or combination of these limits may cause permanent damage to this device.
3. M/A-COM does not recommend sustained operation near these survivability limits.

\* Restrictions on Hazardous Substances, European Union Directive 2002/95/EC.

## 2.5 V GaAs SPDT Switch 0.5 - 3.0 GHz

Rev. V2

**Electrical Specifications:  $T_A = 25^\circ\text{C}$ ,  $V_C = 0\text{ V} / +2.5\text{ V}$ ,  $Z_0 = 50\ \Omega$  <sup>4</sup>**

Parameter	Test Conditions	Units	Min.	Typ.	Max.
Insertion Loss <sup>5</sup>	1 GHz	dB	—	0.30	0.50
	2 GHz	dB	—	0.40	—
	3 GHz	dB	—	0.50	—
Isolation	1 GHz	dB	23	25	—
	2 GHz	dB	—	27	—
	3 GHz	dB	—	24	—
VSWR	0.5 - 3.0 GHz	Ratio	—	1.1	—
IP3	Two Tone, +10 dBm/tone, 5 MHz Spacing, > 50 MHz	dBm	—	48	—
P1dB	—	dBm	—	28	—
Linear Pout	2.5 GHz, OFDM, QAM-64, 54Mbps, EVM=2.5%				
	2.5 V	dBm	—	21.0	—
	3.0 V	dBm	—	23.5	—
	5.0 V	dBm	—	28.5	—
Trise, Tfall	10% to 90% RF, 90% to 10% RF	nS	—	30	—
Ton, Toff	50% control to 90% RF, and 50% control to 10% RF	nS	—	35	—
Transients	In Band	mV	—	60	—
Control Current	$ V_C  = 2.5\text{ V}$	$\mu\text{A}$	—	1	5

4. For positive voltage control, external DC blocking capacitors are required on all RF ports.

5. Insertion Loss can be optimized by varying the DC blocking capacitor value, e.g. 1000 pF for 100 MHz - 500 MHz, 39 pF for 0.5 - 3 GHz.

### Truth Table <sup>6</sup>

V1	V2	RFC - RF1	RFC - RF2
0	1	On	Off
1	0	Off	On

6. 0 =  $0 \pm 0.2\text{ V}$ , 1 = 2.5 to 5 V

### Handling Procedures

Please observe the following precautions to avoid damage:

### Static Sensitivity

Gallium Arsenide Integrated Circuits are sensitive to electrostatic discharge (ESD) and can be damaged by static electricity. Proper ESD control techniques should be used when handling these devices.

## Typical Performance Curves

### Insertion Loss

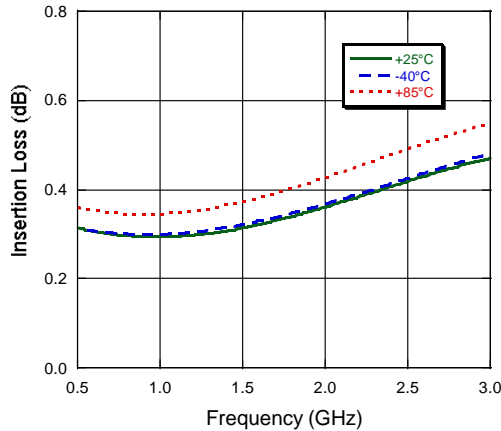

### Isolation

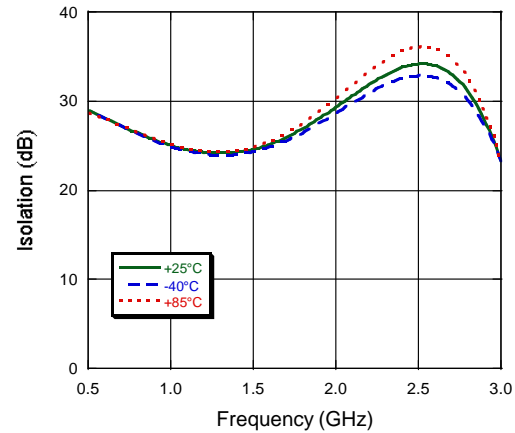

### Return Loss

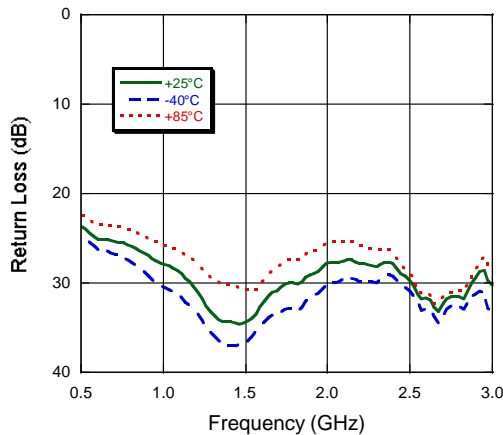

### EVM vs. Pout @ 2.5 GHz

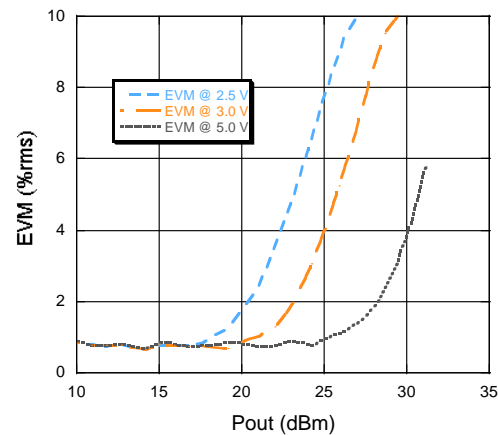

## Lead-Free 1.2 x 1.5 mm 6-Lead PQFN†

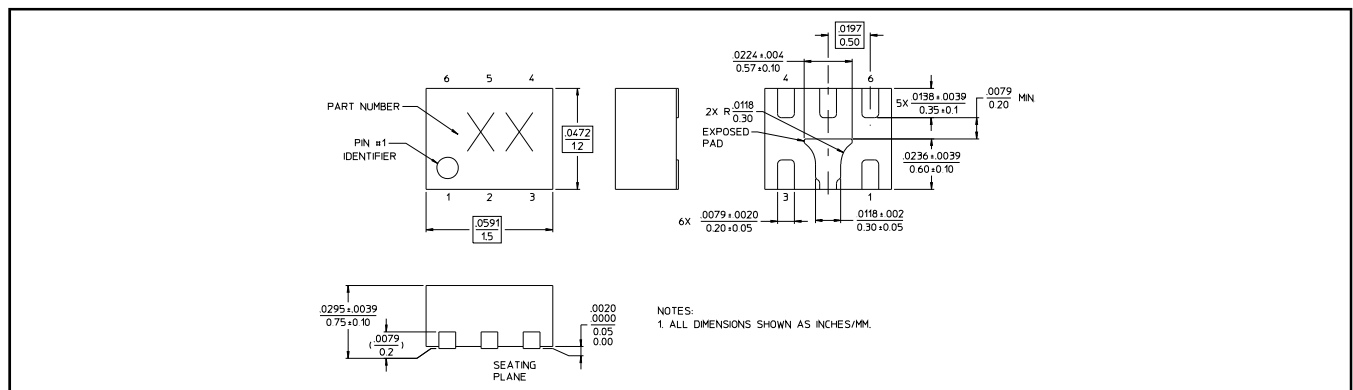

† Reference Application Note M538 for lead-free solder reflow recommendations.  
Meets JEDEC moisture sensitivity level 1 requirements.

**ADVANCED:** Data Sheets contain information regarding a product M/A-COM Technology Solutions is considering for development. Performance is based on target specifications, simulated results, and/or prototype measurements. Commitment to develop is not guaranteed.  
**PRELIMINARY:** Data Sheets contain information regarding a product M/A-COM Technology Solutions has under development. Performance is based on engineering tests. Specifications are typical. Mechanical outline has been fixed. Engineering samples and/or test data may be available. Commitment to produce in volume is not guaranteed.

- **North America** Tel: 800.366.2266 / Fax: 978.366.2266
- **Europe** Tel: 44.1908.574.200 / Fax: 44.1908.574.300
- **Asia/Pacific** Tel: 81.44.844.8296 / Fax: 81.44.844.8298

Visit [www.macomtech.com](http://www.macomtech.com) for additional data sheets and product information.

M/A-COM Technology Solutions Inc. and its affiliates reserve the right to make changes to the product(s) or information contained herein without notice.

Компания «Life Electronics» занимается поставками электронных компонентов импортного и отечественного производства от производителей и со складов крупных дистрибьюторов Европы, Америки и Азии.

С конца 2013 года компания активно расширяет линейку поставок компонентов по направлению коаксиальный кабель, кварцевые генераторы и конденсаторы (керамические, пленочные, электролитические), за счёт заключения дистрибьюторских договоров

Мы предлагаем:

- Конкурентоспособные цены и скидки постоянным клиентам.
- Специальные условия для постоянных клиентов.
- Подбор аналогов.
- Поставку компонентов в любых объемах, удовлетворяющих вашим потребностям.
- Приемлемые сроки поставки, возможна ускоренная поставка.
- Доставку товара в любую точку России и стран СНГ.
- Комплексную поставку.
- Работу по проектам и поставку образцов.
- Формирование склада под заказчика.
- Сертификаты соответствия на поставляемую продукцию (по желанию клиента).
- Тестирование поставляемой продукции.
- Поставку компонентов, требующих военную и космическую приемку.
- Входной контроль качества.
- Наличие сертификата ISO.

В составе нашей компании организован Конструкторский отдел, призванный помогать разработчикам, и инженерам.

Конструкторский отдел помогает осуществить:

- Регистрацию проекта у производителя компонентов.
- Техническую поддержку проекта.
- Защиту от снятия компонента с производства.
- Оценку стоимости проекта по компонентам.
- Изготовление тестовой платы монтаж и пусконаладочные работы.



Тел: +7 (812) 336 43 04 (многоканальный)

Email: [org@lifeelectronics.ru](mailto:org@lifeelectronics.ru)