

UP TO 3 POSITIONS WITH 3 OPTIONAL, INDEPENDENT LED LIGHT POSITIONS, 1.45 X .83 PANEL CUTOUT

Used in the heavy equipment, marine, process control and instrumentation markets the R2 rotary switch is an excellent replacement for rocker switches offering improved visual position indication, additional lighting options and different styling opportunities on front panels. The R2 series is a sealed, lighted rotary switch which snaps into a 1.45 x .83" industry standard rocker switch panel opening. The rotary knob snaps onto a shaft and can be installed by the panel builder for those desiring that flexibility. The R2 rotary switch provides up to 3 positions in all combinations of momentary and maintained action. It is capable of handling loads from logic level to 20 amps (resistive). Sealing is to IP68 (1 meter immersion) via a shaft o-ring seal in front and a potted base in the back. Termination options include .250" fast on, solder lug or a snap on modular connector. The R2 offers unique lighting options including up to three independent LED light positions which illuminate a lens on the rotary knob. This design provides more lighting options than traditional rocker switches, handles the full range of electrical loads and is robust enough to survive in the most demanding applications.



Quality Features:

- Sealed watertight per IP68
- Snap-in panel mounting into industry standard 1.45 x .83 panel cutout
- Unique lighting options up to three independent LED light positions
- Plastic or "Soft Touch" knob options available
- 2 or 3 positions in all combinations of momentary and maintained action
- Termination options include .250" fast on, solder lug or a snap on modular connector

Standard Characteristics/Ratings:			
OPERATIONAL:			
Mechanical Life:	100,000 cycles		
Seal:	Watertight to IP68		
Temperature Range:	-40C to +85C		
MATERIALS:			
Case/Base:	Thermoplastic		
Knob:	Thermoplastic		
Terminals:	Copper alloy; silver plate; gold plate for low level		
Contacts:	Silver alloy; Gold plate for low level		
Panel Thickness:	.025 min to .187 max		
Mounting:	Snap in from front 1.45 x .83 panel cutout		
ELECTRICAL:			
LOAD Type	Current Rating		LIFE (Min.)
	12 & 28 VDC	110 VAC	
Resistive	20 amps	16 amps	25,000 cycles
Inductive	15 amps	15 amps	25,000 cycles
Lamp	4 amps	4 amps	25,000 cycles
Motor Load:	1/2 HP at 110 vac		

ROTARY SWITCH

UP TO 3 POSITIONS WITH 3 OPTIONAL, INDEPENDENT LED LIGHT POSITIONS, 1.45 X .83 PANEL CUTOUT

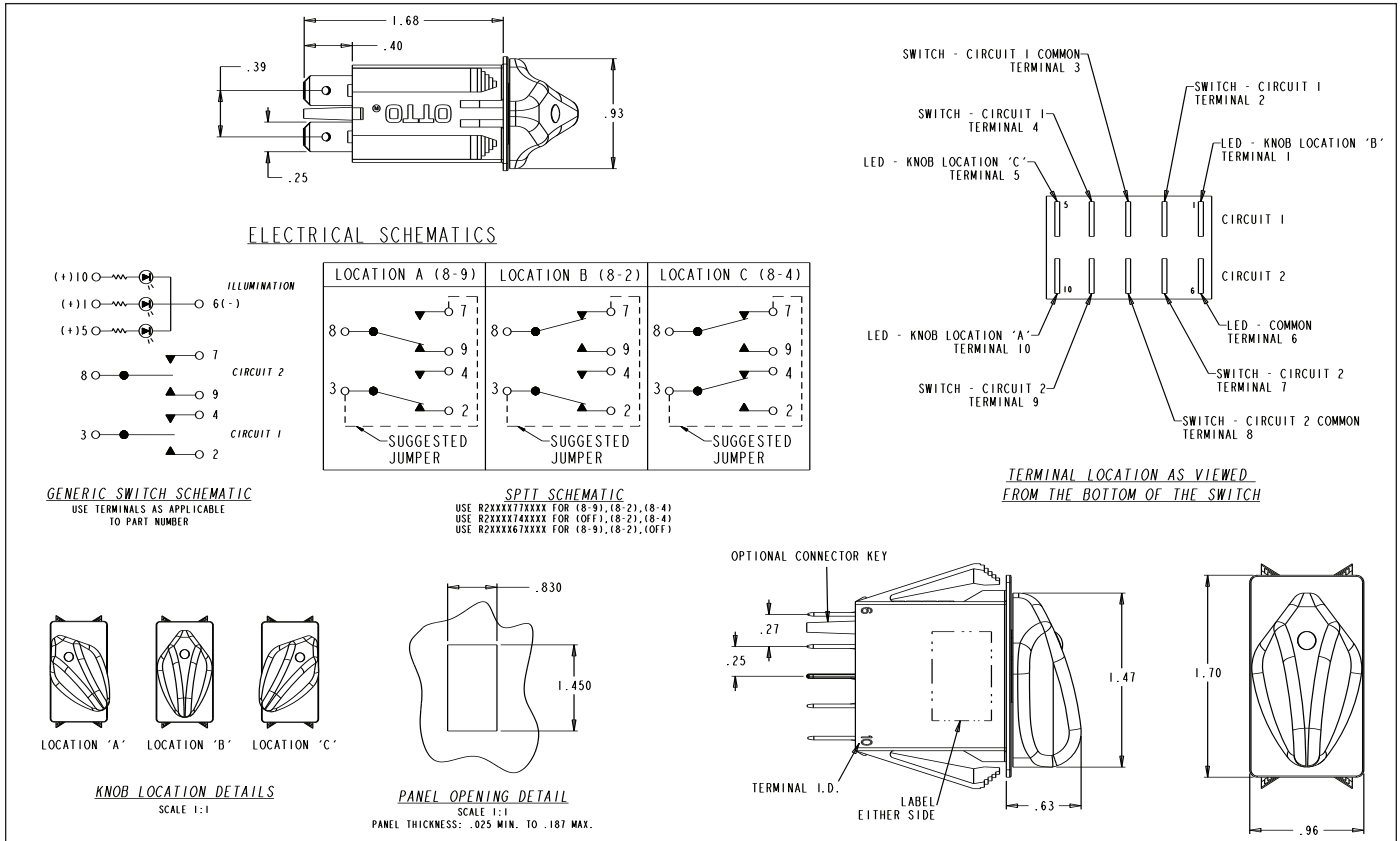

R2	X	X	X	X	X	X	X	X	X
----	---	---	---	---	---	---	---	---	---

TERMINAL STYLE / SWITCH RATING 3RD CHARACTER
A WITHOUT TERMINAL BARRIERS, WITH CONNECTOR KEYING PIN, STANDARD RATING
B WITHOUT TERMINAL BARRIERS, WITHOUT CONNECTOR KEYING PIN, STANDARD RATING
C WITHOUT TERMINAL BARRIERS, WITH CONNECTOR KEYING PIN, LOW LEVEL RATING
D WITHOUT TERMINAL BARRIERS, WITHOUT CONNECTOR KEYING PIN, LOW LEVEL RATING

KNOB COLOR AND TEXTURE 4TH CHARACTER
A BLACK PLASTIC
B BLACK "SOFT TOUCH"
C WHITE PLASTIC
D WHITE "SOFT TOUCH"

SWITCH CONFIGURATIONS 5TH AND 6TH CHARACTERS				
	KNOB LOCATIONS	SWITCH ACTIONS		
		KNOB LOCATION A	KNOB LOCATION B	KNOB LOCATION C
11	2 POSITION A/B	MAINTAIN	MAINTAIN
12	2 POSITION A/B	MAINTAIN	MOMENTARY
13	2 POSITION A/B	MOMENTARY	MAINTAIN
21	2 POSITION A/C	MAINTAIN	MAINTAIN
22	2 POSITION A/C	MAINTAIN	MOMENTARY
23	2 POSITION A/C	MOMENTARY	MAINTAIN
31	2 POSITION B/C	MAINTAIN	MAINTAIN
32	2 POSITION B/C	MAINTAIN	MOMENTARY
33	2 POSITION B/C	MOMENTARY	MAINTAIN
44	3 POSITION A/B/C	MAINTAIN	MAINTAIN	MAINTAIN
45	3 POSITION A/B/C	MOMENTARY	MAINTAIN	MOMENTARY
46	3 POSITION A/B/C	MAINTAIN	MAINTAIN	MOMENTARY
47	3 POSITION A/B/C	MOMENTARY	MAINTAIN	MAINTAIN

SWITCH CIRCUIT 1 - TERMINALS 2, 3, 4 7TH CHARACTER			
KNOB LOCATION A	KNOB LOCATION B	KNOB LOCATION C	
2 POSITION SWITCH (KNOB LOCATIONS A/B)			
1	3-2	OFF
2	OFF	3-4
3	3-2	3-4
2 POSITION SWITCH (KNOB LOCATIONS A/C)			
1	3-2	OFF
2	OFF	3-4
3	3-2	3-4
2 POSITION SWITCH (KNOB LOCATIONS B/C)			
1	3-2	OFF
2	OFF	3-4
3	3-2	3-4
3-POSITION SWITCH			
4	OFF	3-4	3-4
5	3-2	OFF	3-4
6	3-2	3-2	OFF
7	3-2	3-2	3-4
8	3-2	OFF	OFF
9	OFF	OFF	3-4

SWITCH CIRCUIT 2 - TERMINALS 7, 8, 9 8TH CHARACTER			
KNOB LOCATION A	KNOB LOCATION B	KNOB LOCATION C	
NONE (SINGLE POLE SWITCH)			
2 POSITION SWITCH (KNOB LOCATIONS A/B)			
1	8-9	OFF
2	OFF	8-7
3	8-9	8-7
2 POSITION SWITCH (KNOB LOCATIONS A/C)			
1	8-9	OFF
2	OFF	8-7
3	8-9	8-7
2 POSITION SWITCH (KNOB LOCATIONS B/C)			
1	8-9	OFF
2	OFF	8-7
3	8-9	8-7
3-POSITION SWITCH			
4	OFF	8-7	8-7
5	8-9	OFF	8-7
6	8-9	8-9	OFF
7	8-9	8-7	8-7
8	8-9	OFF	OFF
9	OFF	OFF	8-7

LOCATION 'C' LIGHT SOURCE COLOR 12TH CHARACTER	
N	NONE
1	RED
2	GREEN
3	AMBER

LOCATION 'B' LIGHT SOURCE COLOR 11TH CHARACTER	
N	NONE
1	RED
2	GREEN
3	AMBER

LOCATION 'A' LIGHT SOURCE COLOR 10TH CHARACTER	
N	NONE
1	RED
2	GREEN
3	AMBER

LIGHT SOURCE VOLTAGE 9TH CHARACTER	
N	NONE
A	2 V
B	6 V
C	12 V
D	24 V

Компания «Life Electronics» занимается поставками электронных компонентов импортного и отечественного производства от производителей и со складов крупных дистрибьюторов Европы, Америки и Азии.

С конца 2013 года компания активно расширяет линейку поставок компонентов по направлению коаксиальный кабель, кварцевые генераторы и конденсаторы (керамические, пленочные, электролитические), за счёт заключения дистрибьюторских договоров

Мы предлагаем:

- Конкуренспособные цены и скидки постоянным клиентам.
- Специальные условия для постоянных клиентов.
- Подбор аналогов.
- Поставку компонентов в любых объемах, удовлетворяющих вашим потребностям.
- Приемлемые сроки поставки, возможна ускоренная поставка.
- Доставку товара в любую точку России и стран СНГ.
- Комплексную поставку.
- Работу по проектам и поставку образцов.
- Формирование склада под заказчика.
- Сертификаты соответствия на поставляемую продукцию (по желанию клиента).
- Тестирование поставляемой продукции.
- Поставку компонентов, требующих военную и космическую приемку.
- Входной контроль качества.
- Наличие сертификата ISO.

В составе нашей компании организован Конструкторский отдел, призванный помогать разработчикам, и инженерам.

Конструкторский отдел помогает осуществить:

- Регистрацию проекта у производителя компонентов.
- Техническую поддержку проекта.
- Защиту от снятия компонента с производства.
- Оценку стоимости проекта по компонентам.
- Изготовление тестовой платы монтаж и пусконаладочные работы.



Тел: +7 (812) 336 43 04 (многоканальный)
Email: org@lifeelectronics.ru