



Anaren Integrated Radio (AIR)

Low-power RF modules, firmware & development tools that make it easy to 'go wireless'

110L Series

The A110LR09A is an ULTRA low cost, high-performance, FCC & IC certified and ETSI-compliant radio module that incorporates the Texas Instruments CC110L "value line" transceiver chip, all in the industry's smallest package: 9 x 16 x 2.5mm.



A110LR09A

Features

- Frequency range: 902-928 MHz (N. America) and 868-870 MHz (Europe)
- FCC, IC and ETSI compliant, shielded package
FCC ID: X7J-A11072401 // IC: 8975A-A11072401
- Digital RSSI output
- Programmable output power up to +12dBm
- High sensitivity (1.2 kBaud, 1% packet error rate)
-110 dBm at 915 MHz (compliant to FCC/IC)
-115 dBm at 869 MHz (compliant to ETSI)
- Ultra-small package size: 9 x 16 x 2.5mm
- LGA footprint
- RoHS compliant
- Operating temperature -40 to +85°C
- Impedance-controlled, multi-layer PCB
- 1.8 to 3.6 VDC
- Low current consumption (15 mA in RX, 1.2 kBaud, 915 MHz)
- 200 nA sleep mode current consumption
- Efficient SPI interface; all registers can be programmed with one "burst" transfer
- Available in tape & reel and matrix tray
- Module weight approximately 0.4 grams

Benefits

- Minimal RF engineering experience necessary
- No additional "Intentional Radiator" certification required (FCC 15.247a2, IC RSS-210, ETSI EN 300 220)
- Minimal real estate required
- Easily implemented on a two layer PCB
- No additional harmonic filtering required
- 100% RF-tested in production
- Common footprint for similar products in family
- No additional DC decoupling required
- Integrated analog temperature sensor
- Excellent receiver selectivity and blocking performance
- Suitable for frequency hopping systems, thanks to a fast-settling frequency synthesizer with 90 μ s settling time
- Impedance-matched balun for optimized efficiency
- Support for asynchronous and synchronous serial receive/transmit mode for backwards compatibility with existing radio

PLEASE NOTE: Additional information on the Texas Instruments CC110L device can be found in the company's latest datasheet release at <http://www.ti.com>

Block diagram

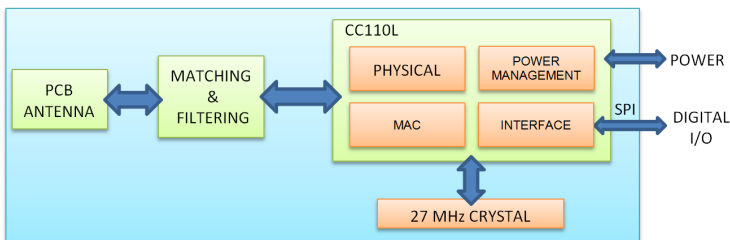

This product is not to be used in any implantable medical device or external medical device intended to regulate or monitor biological functions, including but not limited to devices such as pacemakers, defibrillators, cardiac resynchronization devices, pressure sensors, biochemical stimulators and neurostimulators. ANAREN MAKES NO WARRANTY OF FITNESS OR MERCHANTABILITY OF THIS PRODUCT FOR ANY USE OF THIS TYPE. Anaren shall not be responsible for any consequential damages arising from the sale or use of this product for any use of this type. The ultimate user of the product assumes all risk of personal injury or death arising from a prohibited use.



The item described in this product brief is part of our total AIR Support solution. To learn more, visit our website or just ask us!



Anaren®
What'll we think of next?®

Anaren, Inc. | 6635 Kirkville Road | East Syracuse, NY 13057
800.411.6596 | www.anaren.com | AIR@anaren.com



Anaren Integrated Radio (AIR)

Low-power RF modules, firmware & development tools that make it easy to 'go wireless'

Product overview

The A110LR09A is a high-performance, dual-band FCC & IC certified and ETSI compliant radio module that incorporates the Texas Instruments CC110L "value line" low-cost transceiver chip in the industry's smallest package (9 x 16 x 2.5mm) and is compatible with all TI-approved software stacks.

With an LGA pad footprint, this module is designed to effortlessly integrate into a wide range of applications, including: industrial control, building automation, low-power wireless sensor networks, lighting control, and automated meter reading.

The A110LR09A has an RoHS-compliant ENIG finish and is packaged on tape & reel or in matrix trays for high-volume automated manufacturing.

Pin diagram

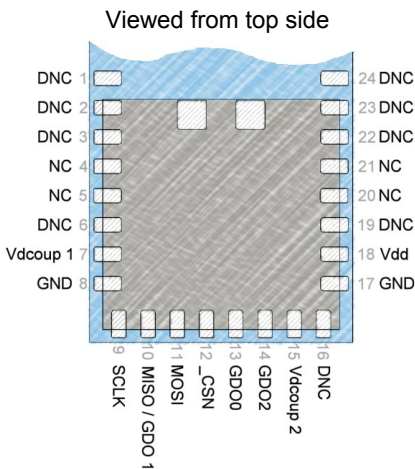

NC = "NO Connection"
Pin is NOT connected internally.

DNC = "Do Not Connect"
Pin reserved for internal use, ensure mating footprint pads are **isolated**.

GND = "Ground"
Connect the maximum number possible (minimum **one** for proper operation).

Layout Information

Refer to User's Manual for additional layout guidelines.
Dimensions in mm.

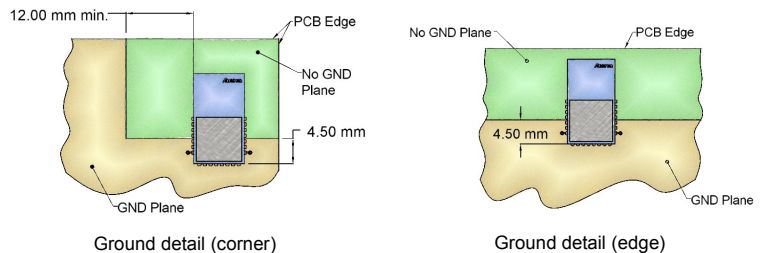
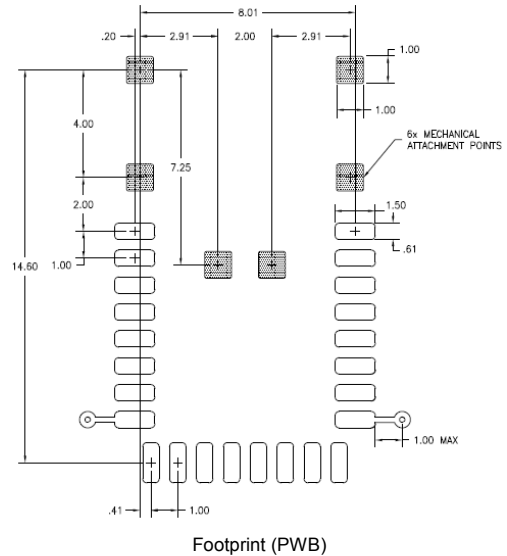

Nomenclature

A110LR09A00GR

① ② ③ ④ ⑤ ⑥ ⑦

- | | |
|---|---|
| A | (Anaren) |
| 1 | Chip series (CC1101, CC110L, CC2500) |
| 2 | Function (R = radio only) |
| 3 | Frequency band (x100MHz) |
| 4 | Form factor (A = Internal Antenna, C = Connector) |
| 5 | Design ID (00 = Default) |
| 6 | Application (G = General) |
| 7 | Packaging (R = Tape/Reel, M = Matrix Tray) |



Caution! ESD sensitive device. Precautions should be used when handling the device in order to prevent permanent damage.



The item described in this product brief is part of our total AIR Support solution. To learn more, visit our website or just ask us!

For more information see product User's Manual, available online.



Anaren® 1308a
What'll we think of next?®

Anaren, Inc. | 6635 Kirkville Road | East Syracuse, NY 13057
800.411.6596 | www.anaren.com | AIR@anaren.com

Компания «Life Electronics» занимается поставками электронных компонентов импортного и отечественного производства от производителей и со складов крупных дистрибьюторов Европы, Америки и Азии.

С конца 2013 года компания активно расширяет линейку поставок компонентов по направлению коаксиальный кабель, кварцевые генераторы и конденсаторы (керамические, пленочные, электролитические), за счёт заключения дистрибьюторских договоров

Мы предлагаем:

- Конкуренеспособные цены и скидки постоянным клиентам.
- Специальные условия для постоянных клиентов.
- Подбор аналогов.
- Поставку компонентов в любых объемах, удовлетворяющих вашим потребностям.
- Приемлемые сроки поставки, возможна ускоренная поставка.
- Доставку товара в любую точку России и стран СНГ.
- Комплексную поставку.
- Работу по проектам и поставку образцов.
- Формирование склада под заказчика.
- Сертификаты соответствия на поставляемую продукцию (по желанию клиента).
- Тестирование поставляемой продукции.
- Поставку компонентов, требующих военную и космическую приемку.
- Входной контроль качества.
- Наличие сертификата ISO.

В составе нашей компании организован Конструкторский отдел, призванный помогать разработчикам, и инженерам.

Конструкторский отдел помогает осуществить:

- Регистрацию проекта у производителя компонентов.
- Техническую поддержку проекта.
- Защиту от снятия компонента с производства.
- Оценку стоимости проекта по компонентам.
- Изготовление тестовой платы монтаж и пусконаладочные работы.



Тел: +7 (812) 336 43 04 (многоканальный)

Email: org@lifeelectronics.ru