

THIS DRAWING IS UNPUBLISHED. RELEASED FOR PUBLICATION
 © COPYRIGHT - By - ALL RIGHTS RESERVED.

LOC	DIST	REVISIONS				
		P	LTR	DESCRIPTION	DATE	DWN
-	-	B7	PRELIMINARY	16DEC2014	D.Z	S.L

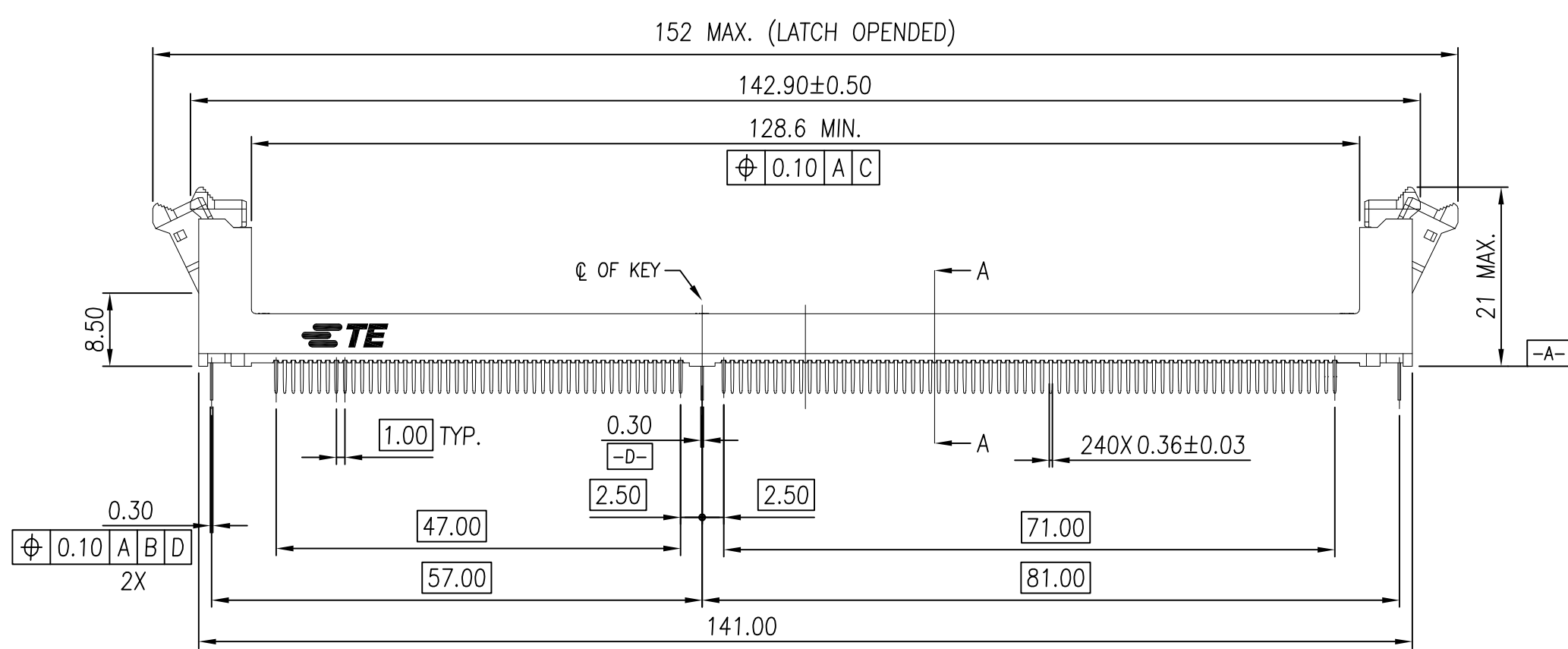
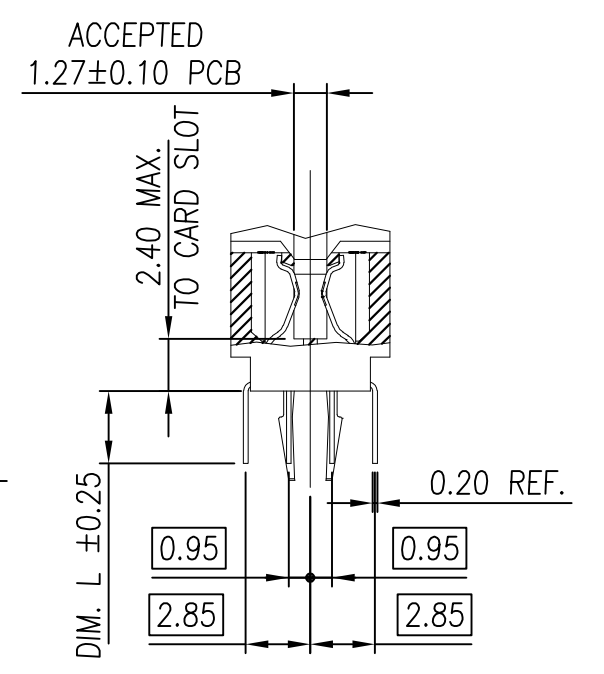
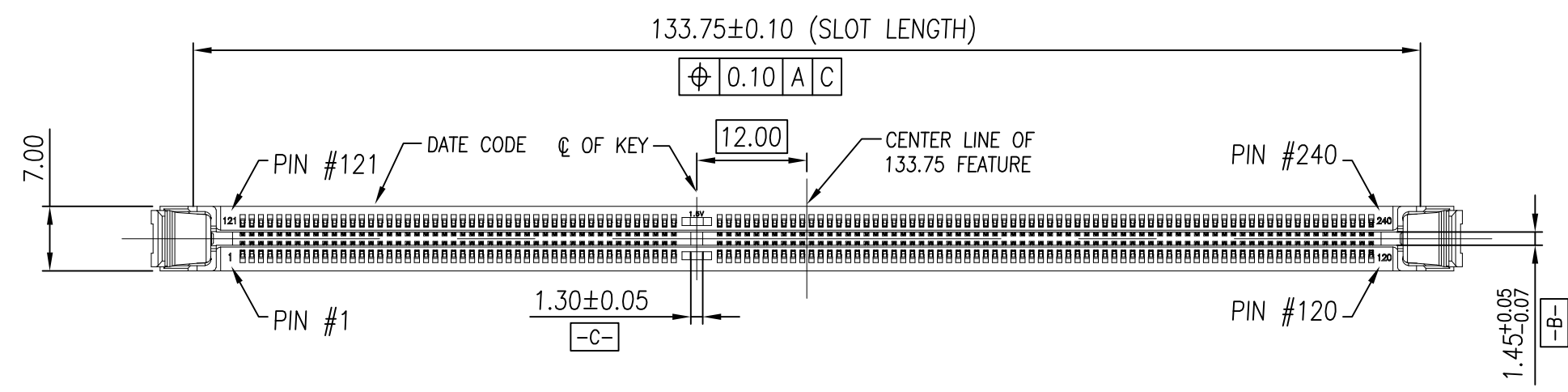

THIS DRAWING IS A CONTROLLED DOCUMENT.		DWN SIMON WU 30DEC2010	 PRELIMINARY TE Connectivity			
DIMENSIONS: mm		CHK BILL WONG 30DEC2010				
TOLERANCES UNLESS OTHERWISE SPECIFIED:		APVD COREL WANG 30DEC2010				
0 PLC ± - 1 PLC ± 0.30 2 PLC ± 0.15 3 PLC ± - 4 PLC ± - ANGLES ± 1°		NAME				
MATERIAL SEE NOTE		FINISH SEE NOTE	PRODUCT SPEC 108-115019	SOCKET ASSEMBLY VLP DDR-III, T/H, 240P		
		APPLIC. SPEC	SIZE	CAGE CODE	DRAWING NO	RESTRICTED TO
		WEIGHT 7.82	A3	00779	C-1932680	-
CUSTOMER DRAWING			SCALE 3:2	SHEET 1 OF 6	REV B7	

THIS DRAWING IS UNPUBLISHED. RELEASED FOR PUBLICATION
 © COPYRIGHT - By - ALL RIGHTS RESERVED.

LOC	DIST	REVISIONS			
P	LTR	DESCRIPTION	DATE	DWN	APVD
-	-	SEE SHEET 1	-	-	-

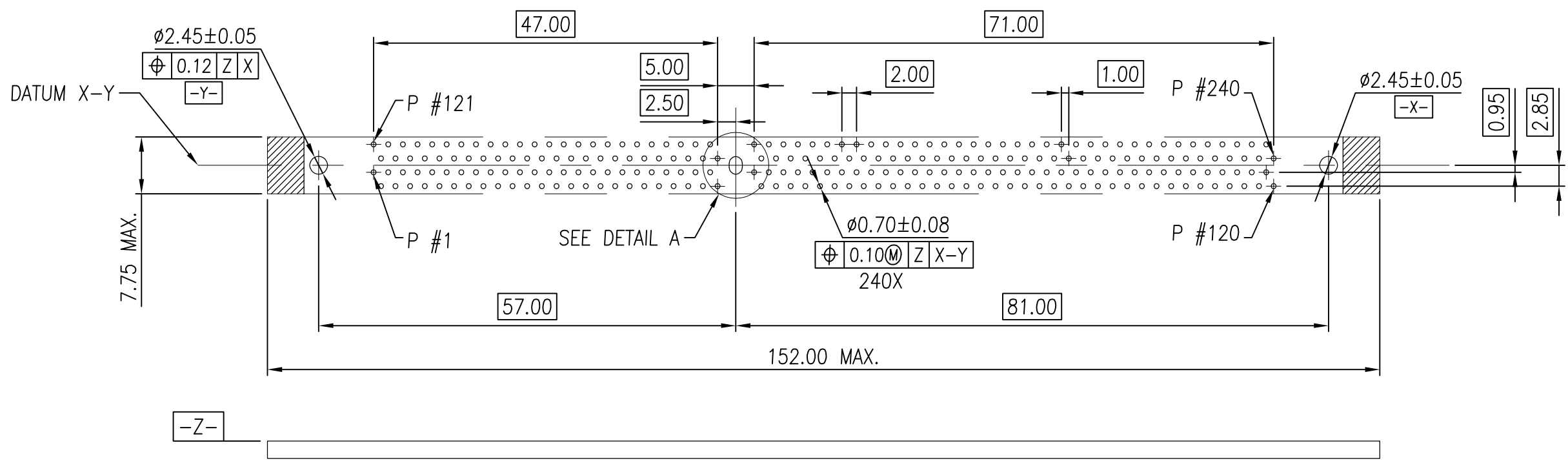

RECOMMENDED PCB LAYOUT (TOP VIEW)

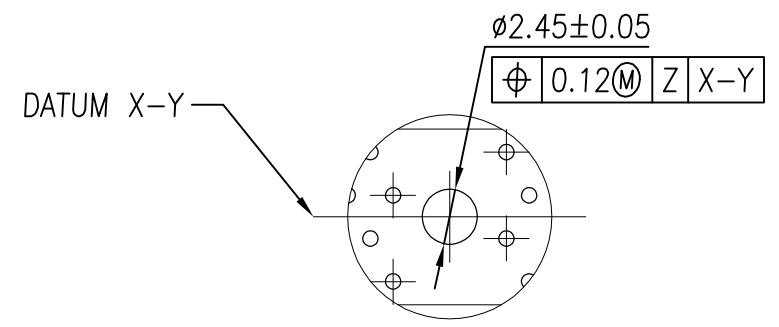

OPTION 1:
CENTER ROUND
HOLE

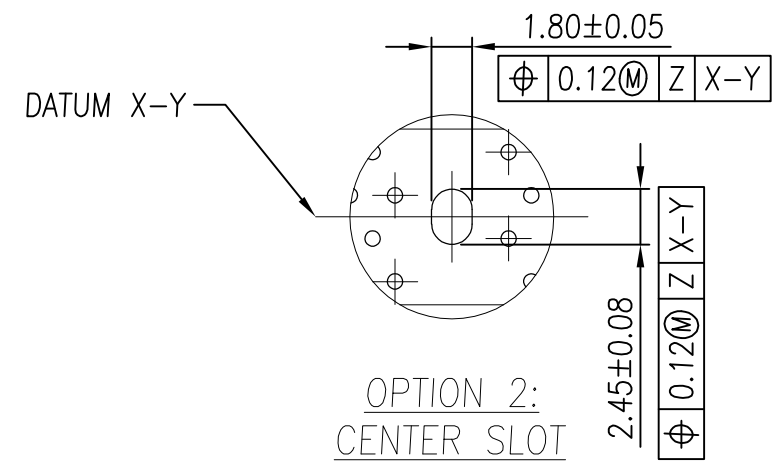

OPTION 2:
CENTER SLOT

DETAIL A
SCALE 3:1

THIS DRAWING IS A CONTROLLED DOCUMENT.		DWN SIMON WU 30DEC2010	 TE Connectivity				
DIMENSIONS: mm		CHK BILL WONG 30DEC2010					
TOLERANCES UNLESS OTHERWISE SPECIFIED:		APVD COREL WANG 30DEC2010	NAME				
0 PLC ± - 1 PLC ± 0.30 2 PLC ± 0.15 3 PLC ± - 4 PLC ± - ANGLES ± 1°		PRODUCT SPEC	SOCKET ASSEMBLY VLP DDR-III, T/H, 240P				
MATERIAL SEE NOTE		FINISH SEE NOTE	APPLICATION SPEC	SIZE A3	CAGE CODE 00779	DRAWING NO C-1932680	RESTRICTED TO
CUSTOMER DRAWING			WEIGHT -	SCALE 3:2	SHEET 2 OF 6	REV B7	

THIS DRAWING IS UNPUBLISHED. RELEASED FOR PUBLICATION
 © COPYRIGHT - By - ALL RIGHTS RESERVED.

LOC	DIST	P	LTR	DESCRIPTION	DATE	DWN	APVD
-	-	-	-	SEE SHEET 1	-	-	-

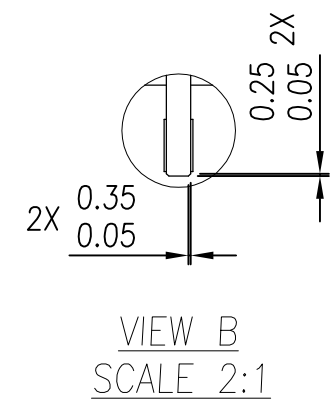
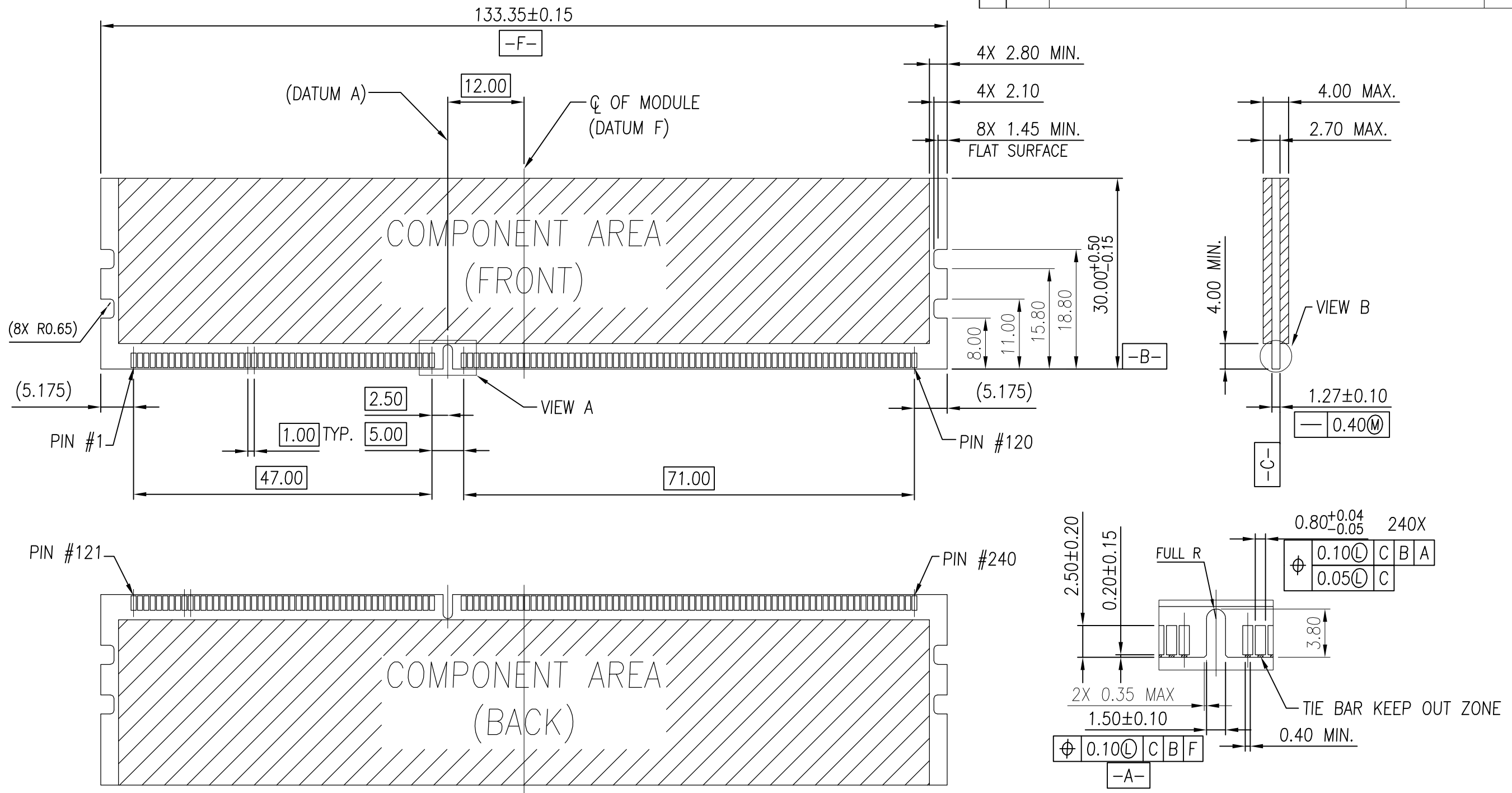

THIS DRAWING IS A CONTROLLED DOCUMENT.		DWN SIMON WU 30DEC2010	TE Connectivity		
DIMENSIONS: mm		CHK BILL WONG 30DEC2010			
TOLERANCES UNLESS OTHERWISE SPECIFIED:		APVD COREL WANG 30DEC2010	NAME		
0 PLC ± -		PRODUCT SPEC	SOCKET ASSEMBLY VLP DDR-III, T/H, 240P		
1 PLC ± 0.30		APPLICATION SPEC	SIZE	CAGE CODE	DRAWING NO
2 PLC ± 0.15		WEIGHT	A3	00779	C-1932680
3 PLC ± -		MATERIAL	RESTRICTED TO		
4 PLC ± -		FINISH	SCALE 3:2 SHEET 3 OF 6 REV B7		
ANGLES ± 1°		SEE NOTE	CUSTOMER DRAWING		

THIS DRAWING IS UNPUBLISHED. RELEASED FOR PUBLICATION
 © COPYRIGHT - By - ALL RIGHTS RESERVED.

LOC	DIST	REVISIONS			
P	LTR	DESCRIPTION	DATE	DWN	APVD
-	-	SEE SHEET 1	-	-	-

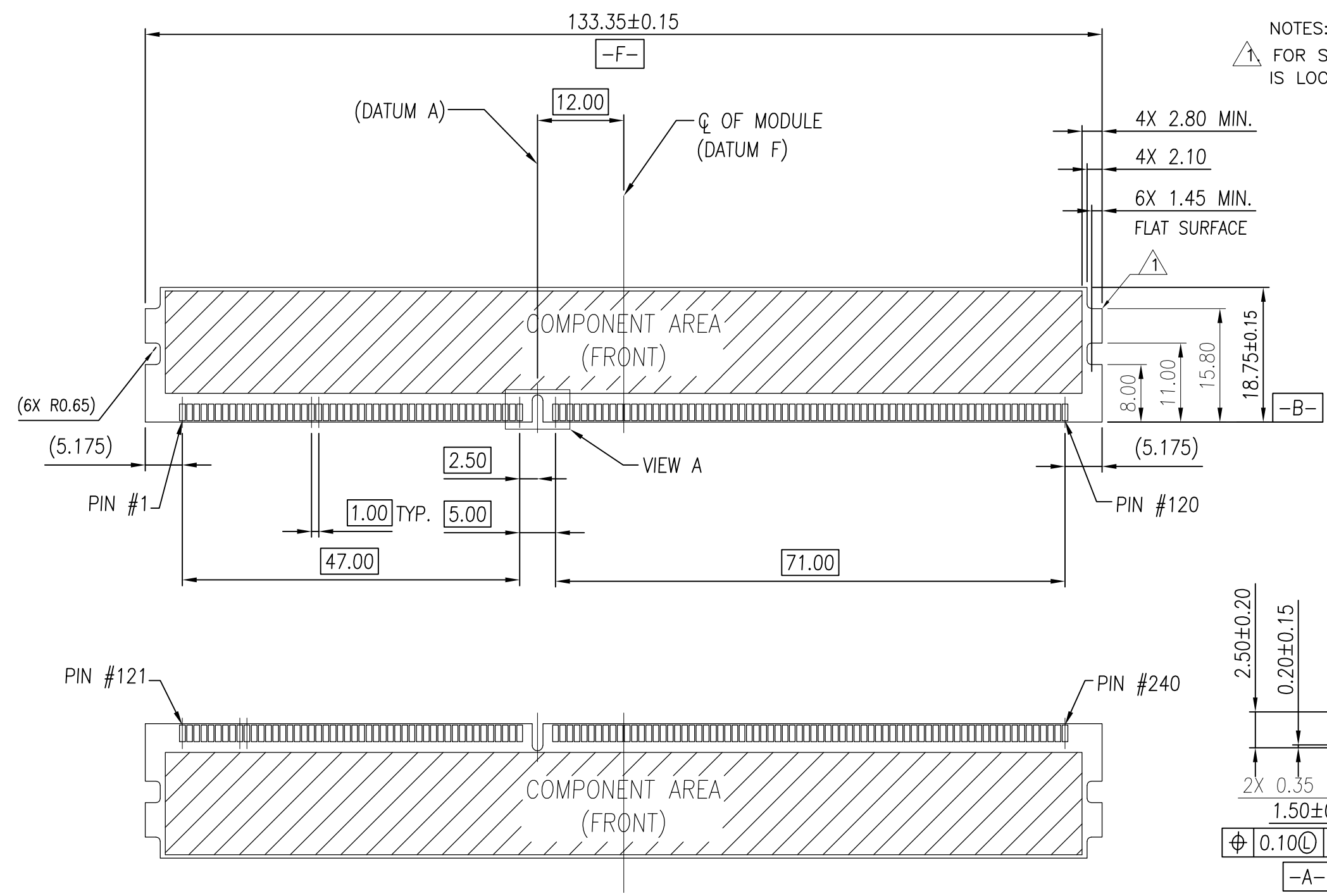

NOTES:
 △ FOR STD VLP MODULE, THE LATCH OF CONNECTOR IS LOCKED BY UPPER NOTCH.

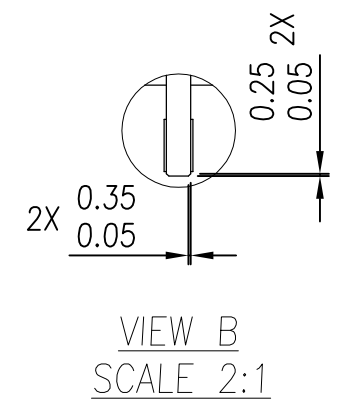
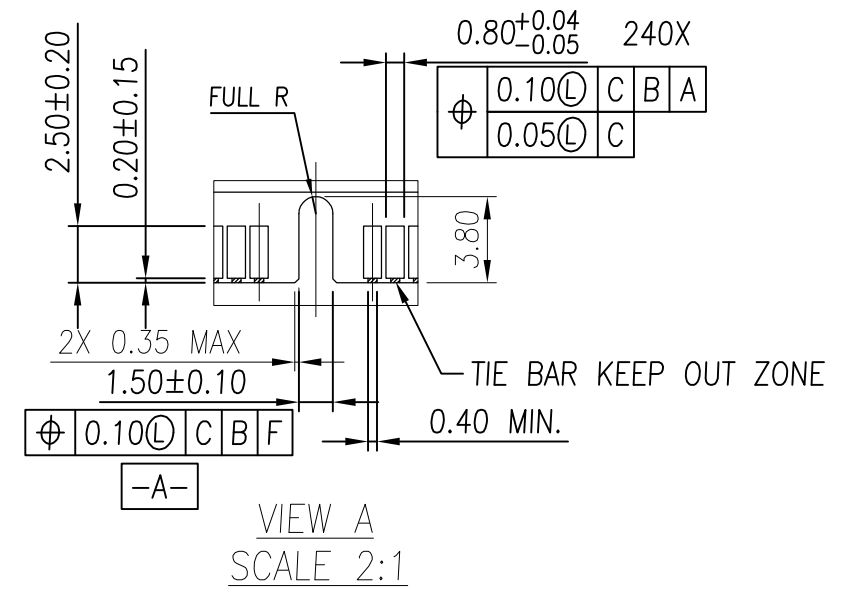
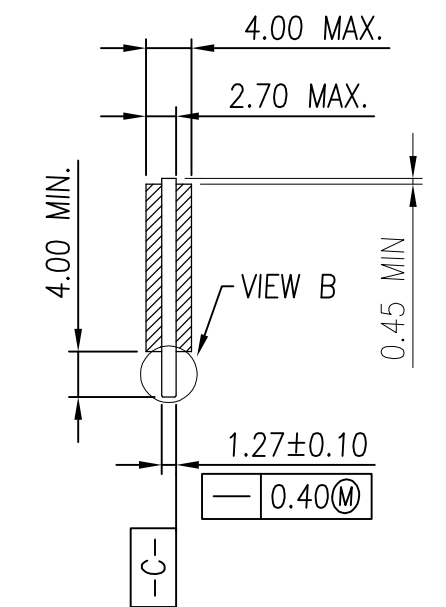

THIS DRAWING IS A CONTROLLED DOCUMENT.		DWN SIMON WU 30DEC2010	TE Connectivity		
DIMENSIONS: mm		CHK BILL WONG 30DEC2010			
TOLERANCES UNLESS OTHERWISE SPECIFIED:		APVD COREL WANG 30DEC2010	NAME		
0 PLC ± -		PRODUCT SPEC	SOCKET ASSEMBLY VLP DDR-III, T/H, 240P		
1 PLC ± 0.30		APPLICATION SPEC	SIZE	CAGE CODE	DRAWING NO
2 PLC ± 0.15		WEIGHT	A3	00779	C-1932680
3 PLC ± -		MATERIAL	RESTRICTED TO		
4 PLC ± -		FINISH	SCALE 3:2 SHEET 4 OF 6 REV B7		
ANGLES ± 1°		SEE NOTE	CUSTOMER DRAWING		

THIS DRAWING IS UNPUBLISHED. RELEASED FOR PUBLICATION
 © COPYRIGHT - By - ALL RIGHTS RESERVED.

LOC		DIST		REVISIONS			
P	LTR	DESCRIPTION		DATE	DWN	APVD	
-	-	-	-	SEE SHEET 1	-	-	

NOTES:

1. MATERIAL:
 - 1.1 HOUSING: THERMOPLASTIC, UL94V-0; COLOR: SEE TABLE.
 - 1.2 LATCH: THERMOPLASTIC, UL94V-0; COLOR: SEE TABLE.
 - 1.3 CONTACT: COPPER ALLOY.
 - 1.4 BOARDLOCK: COPPER ALLOY.
2. FINISH:
 - 2.1 CONTACT:
 - GOLD PLATING THICKNESS ON CONTACT AREA: SEE TABLE.
 - THICKNESS 100u" MIN. MATTE-TIN PLATING ON SOLDER TAIL AREA.
 - THICKNESS 90u" MIN. NICKEL UNDERPLATING OVERALL FOR 20u" GOLDPLATING.
 - THICKNESS 50u" MIN. NICKEL UNDERPLATING OVERALL FOR OTHER GOLDPLATING.
 - SEALANT APPLY IN PLATING PROCESS.
 - 2.2 BOARDLOCK:
 - THICKNESS 50u" MIN. NICKEL UNDERPLATING OVERALL.
 - THICKNESS 100u" MIN. MATTE-TIN PLATING OVERALL.

3. CONFORMS TO THE REQUIREMENTS OF EIA/ECA-364-1000.01A (CONTROLLED ENVIRONMENT APPLICATIONS, AND TE PRODUCT SPECIFICATION.)

- 4. LLCR SPEC.: 30mΩ MAX. INITIAL, THE CHANGE NOT GREATER THAN 20mΩ AFTER ALL ENVIRONMENT TEST.
- 5. LLCR SPEC.: 10mΩ MAX. INITIAL, THE CHANGE NOT GREATER THAN 10mΩ AFTER ALL ENVIRONMENT TEST.

SEE NOTE 5	4.00	4.00	30u" MIN	NATURAL	BLACK	2-1932680-3
SEE NOTE 5	2.67	3.50	15u" MIN	NATURAL	BLUE(2935U)	2-1932680-2
SEE NOTE 5	2.67	3.50	15u" MIN	NATURAL	BLACK	2-1932680-1
SEE NOTE 5	3.18	4.00	30u" MIN	BLACK	BLACK	2-1932680-0
SEE NOTE 5	3.18	4.00	20u" MIN	GREEN(375C)	BLACK	1-1932680-9
			15u" MIN	NATURAL	BLUE(2935U)	1-1932680-8
			15u" MIN	NATURAL	BLACK	1-1932680-7
			20u" MIN	NATURAL	BLACK	1-1932680-6
SEE NOTE 5	2.54	3.50	20u" MIN	BLACK	BLACK	1-1932680-5
			20u" MIN	GREEN(375C)	BLACK	1-1932680-4
SEE NOTE 5	2.54	3.50	20u" MIN	NATURAL	BLACK	1-1932680-3
			20u" MIN	BLACK	BLACK	1-1932680-2
SEE NOTE 5	3.18	4.00	30u" MIN	NATURAL	BLACK	1-1932680-1
			20u" MIN	GREEN(375C)	BLACK	1-1932680-0
			15u" MIN	NATURAL	BLUE(2935U)	1932680-8
			15u" MIN	NATURAL	BLACK	1932680-6
SEE NOTE 4	3.18	4.00	20u" MIN	NATURAL	BLACK	1932680-4
			20u" MIN	BLACK	BLACK	1932680-2
LLCR SPEC.	DIM. L	DIM. D	CONTACT GOLD PLATING	LATCH COLOR	HOUSING COLOR	PART NUMBER

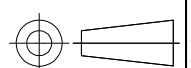
THIS DRAWING IS A CONTROLLED DOCUMENT.		DWN SIMON WU 30DEC2010	 TE Connectivity					
DIMENSIONS: mm		CHK BILL WONG 30DEC2010					NAME	
		APVD COREL WANG 30DEC2010	PRODUCT SPEC		SOCKET ASSEMBLY VLP DDR-III, T/H, 240P			
TOLERANCES UNLESS OTHERWISE SPECIFIED:		APPLICATION SPEC		SIZE	CAGE CODE	DRAWING NO	RESTRICTED TO	
0 PLC ± - 1 PLC ± 0.30 2 PLC ± 0.15 3 PLC ± - 4 PLC ± - ANGLES ± 1°		WEIGHT		A3	00779	C-1932680	-	
MATERIAL SEE NOTE		FINISH SEE NOTE		CUSTOMER DRAWING		SCALE 3:2	SHEET 5 OF 6	REV B7

THIS DRAWING IS UNPUBLISHED. RELEASED FOR PUBLICATION
 © COPYRIGHT - By - ALL RIGHTS RESERVED.

LOC	DIST	REVISIONS					
		P	LTR	DESCRIPTION	DATE	DWN	APVD
-	-	-	-	SEE SHEET 1	-	-	-

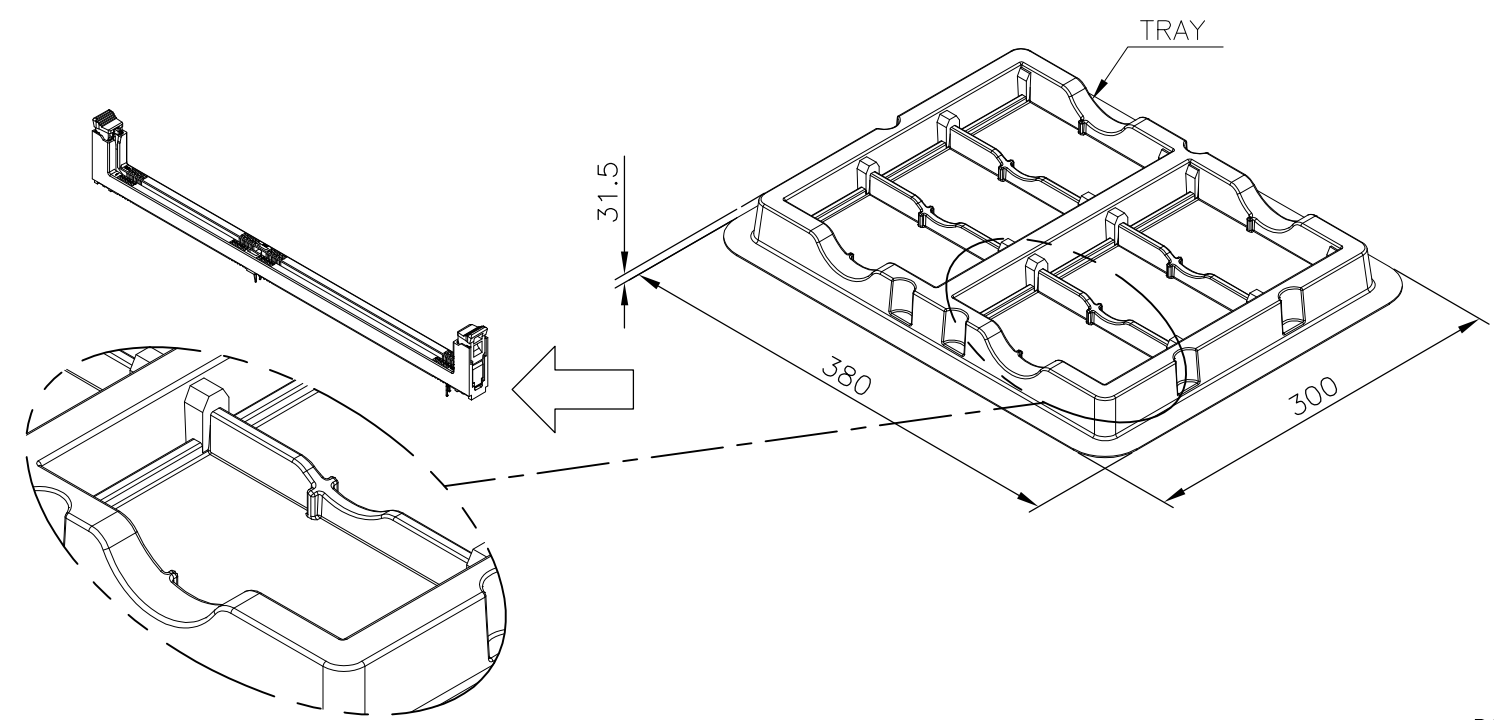

NOTES :
 PACKING MATERIAL MET TE SPEC TEC-138-702.
 * CADMIUM AND CADMIUM COMPOUNDS CONTENT:
 5 PPM UNDER (PLASTIC, RUBBER, INK, PIGMENT, PAINT)
 * LEAD, CADMIUM, CHROM VI AND MERCURY IN PACKAGING
 MATERIALS CONTENT: 100 PPM (COMBINED) UNDER.

- MATERIAL :
 TRAY: PVC, COLOR: TRANSPARENT.
 BOX: CORRUGATED FIBER
 TRANSPARENT BAG: PE, SIZE: 600mm*450mm*0.06mm
- EACH BAG SHALL BE INCLUDED:
 * DESICCANT

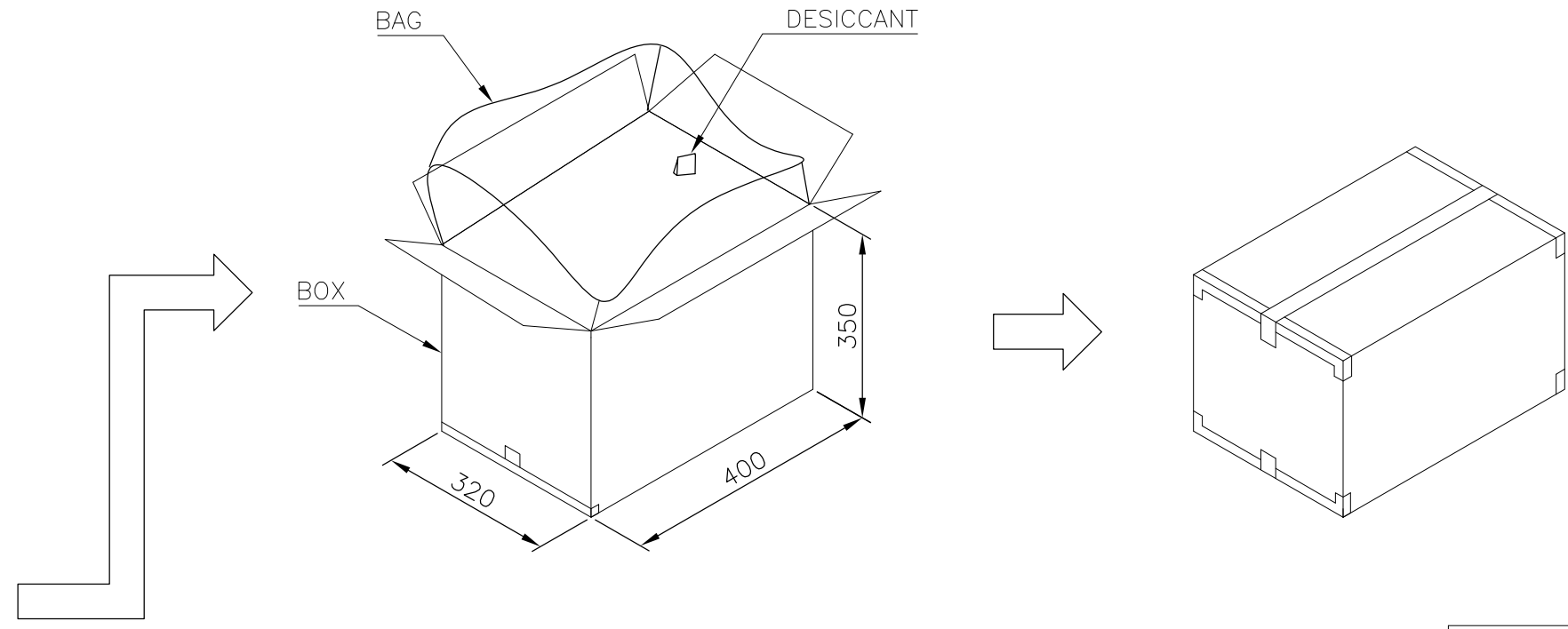
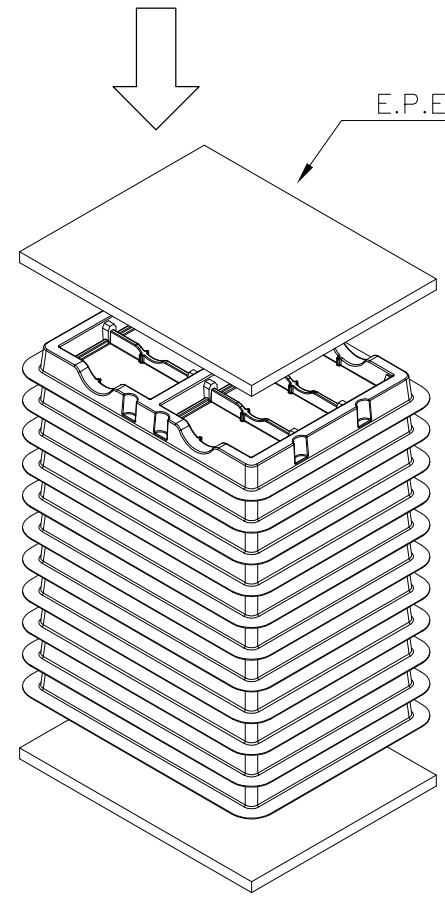

X.X KG	X.X KG	54	10	540
GROSS WEIGHT	NET WEIGHT	PCS/ TRAY	TRAY/ BOX	PCS/ BOX

THIS DRAWING IS A CONTROLLED DOCUMENT.		DWN SIMON WU 30DEC2010	STE TE Connectivity		
DIMENSIONS: mm		CHK BILL WONG 30DEC2010			
TOLERANCES UNLESS OTHERWISE SPECIFIED:		APVD COREL WANG 30DEC2010	SOCKET ASSEMBLY VLP DDR-III, T/H, 240P		
0 PLC ± -		PRODUCT SPEC	SIZE		
1 PLC ± 0.30		APPLICATION SPEC	CAGE CODE	DRAWING NO	RESTRICTED TO
2 PLC ± 0.15		WEIGHT	A3	00779	C-1932680
3 PLC ± -		MATERIAL	CUSTOMER DRAWING		
4 PLC ± -		FINISH	SCALE	SHEET	REV
ANGLES ± 1°		SEE NOTE	N/A	6 OF 6	B7

Компания «Life Electronics» занимается поставками электронных компонентов импортного и отечественного производства от производителей и со складов крупных дистрибьюторов Европы, Америки и Азии.

С конца 2013 года компания активно расширяет линейку поставок компонентов по направлению коаксиальный кабель, кварцевые генераторы и конденсаторы (керамические, пленочные, электролитические), за счёт заключения дистрибьюторских договоров

Мы предлагаем:

- Конкурентоспособные цены и скидки постоянным клиентам.
- Специальные условия для постоянных клиентов.
- Подбор аналогов.
- Поставку компонентов в любых объемах, удовлетворяющих вашим потребностям.
- Приемлемые сроки поставки, возможна ускоренная поставка.
- Доставку товара в любую точку России и стран СНГ.
- Комплексную поставку.
- Работу по проектам и поставку образцов.
- Формирование склада под заказчика.
- Сертификаты соответствия на поставляемую продукцию (по желанию клиента).
- Тестирование поставляемой продукции.
- Поставку компонентов, требующих военную и космическую приемку.
- Входной контроль качества.
- Наличие сертификата ISO.

В составе нашей компании организован Конструкторский отдел, призванный помогать разработчикам, и инженерам.

Конструкторский отдел помогает осуществить:

- Регистрацию проекта у производителя компонентов.
- Техническую поддержку проекта.
- Защиту от снятия компонента с производства.
- Оценку стоимости проекта по компонентам.
- Изготовление тестовой платы монтаж и пусконаладочные работы.



Тел: +7 (812) 336 43 04 (многоканальный)

Email: org@lifeelectronics.ru