

The S-35199A01 is a CMOS 3-wire real-time clock IC which operates with the very low current consumption and in the wide range of operation voltage. The operation voltage is 1.3 V to 5.5 V so that this IC can be used for various power supplies from main supply to backup battery. Due to the 0.34  $\mu$ A current consumption and wide range of power supply voltage at time keeping, this IC makes the battery life longer. In the system which operates with a backup battery, the included free registers can be used as the function for user's backup memory. Users always can take back the information in the registers which is stored before power-off the main power supply, after the voltage is restored.

This IC has the function to correct advance/delay of the clock data speed, in the wide range, which is caused by the oscillation circuit's frequency deviation. Correcting according to the temperature change by combining this function and a temperature sensor, it is possible to make a high precise clock function which is not affected by the ambient temperature. This IC has the function for the external microcomputer's sub clock to output the 32.768 kHz clock pulse. And for this output, users can select either of Nch open drain or CMOS.

Moreover, this IC has a 24-bit binary up counter. This counter counts up every 60 sec from power-on so that users are able to grasp the elapsed time from power-on up to 30 years.

## ■ Features

- Low current consumption : 0.34  $\mu$ A typ. ( $V_{DD} = 3.0$  V,  $T_a = 25^\circ\text{C}$ )
- Wide range of operating voltage : 1.3 to 5.5 V
- Built-in clock-correction function
- Clock pulse output (CMOS output, function to select frequency)
- 32.768 kHz clock pulse output (Nch open-drain, output control pin)
- Built-in 24-bit binary up counter
- Built-in free user register
- 3-wire (micro wire) CPU interface
- Built-in alarm interrupter
- Built-in flag generator during detection of low power voltage or at power-on
- Auto calendar up to the year 2099, automatic leap year calculation function
- Built-in constant voltage circuit
- Built-in 32.768 kHz crystal oscillator ( $C_d$  built in,  $C_g$  external)
- Lead-free, halogen-free

## ■ Applications

- Mobile game devices
- Mobile AV devices
- Digital still cameras
- Digital video cameras
- Electronic power meters
- DVD recorders
- TVs, VCRs
- Mobile phones, PHS
- Car navigation

## ■ Package

- WLP-12A

■ Pin Configuration

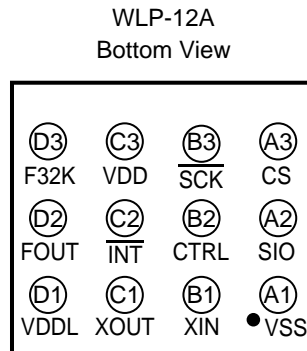

(1.84 × 1.97 × 0.6 max)

Figure 1

■ Marking Specifications

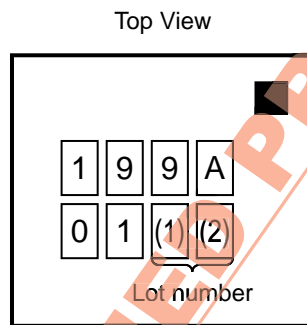

Figure 2

■ List of Pin

Table 1

Pin No.	Symbol	Description	I/O	Configuration
A1	VSS	GND pin	–	–
B1	XIN	Connection pin for crystal oscillator	–	–
C1	XOUT			
D1	VDDL	Power supply pin for FO <span style="font-variant: small-caps;">U</span> T output	–	–
A2	SIO	I/O pin for serial data	Bi-directional	Nch open-drain output (no protective diode at VDD) CMOS input
B2	CTRL	Control pin for F32K output	Input	CMOS input (built-in pull-down resistor. no protective diode at VDD)
C2	$\overline{\text{INT}}$	Output pin for interrupt signal	Output	Nch open-drain output (no protective diode at VDD)
D2	FO <span style="font-variant: small-caps;">U</span> T	Output pin for clock pulse signal	Output	CMOS output
A3	CS	Input pin for chip select	Input	CMOS input (built-in pull-down resistor. no protective diode at VDD)
B3	$\overline{\text{SCK}}$	Input pin for serial clock	Input	CMOS input (no protective diode at VDD)
C3	VDD	Pin for positive power supply	–	–
D3	F32K	Pin for 32.768 kHz output	Output	Nch open-drain output (no protective diode at VDD)

## ■ Pin Function

- CS (input for chip select) pin

This pin is to input chip select, has a pull-down resistor. Communication is available when this pin is in “H” level. If not using communication, set this pin “L” or open.

- SIO (I/O for serial data) pin

This pin is to data input/output for serial interface. When the CS pin is in “H”, the SIO pin inputs/outputs data by synchronizing with a clock pulse from the  $\overline{\text{SCK}}$  pin. The status is in high impedance when the CS pin is in “L” or open, so that the S-35199A01 does not transmit data. Setting the CS pin to “H” level from “L” or open, this SIO pin goes in the input status so that it receives the command data. This pin has CMOS input and Nch open drain output.

- $\overline{\text{SCK}}$  (input for serial clock) pin

This pin is to input a clock pulse for serial interface. When the CS pin is in “H”, the SIO pin inputs/outputs data by synchronizing with the clock pulse. When the CS pin is in “L” or open, the  $\overline{\text{SCK}}$  pin does not accept inputting a clock pulse.

- XIN, XOUT (crystal oscillator connect) pin

Connect a crystal oscillator between XIN and XOUT.

- $\overline{\text{INT}}$  (output for interrupt signal) pin

This pin outputs a signal of interrupt, or a clock pulse. By using the status register 2, users can select either of; alarm 1 interrupt, alarm 2 interrupt, output of user-set frequency, per-minute edge interrupt, minute-periodical interrupt 1, minute-periodical interrupt 2, or 32.768 kHz output. This pin has Nch open drain output.

- CTRL (F32K output control) pin

This pin is to control output from the F32K pin, has a pull-down resistor. This pin outputs a clock pulse from the F32K pin when the CTRL pin is in “H”. It does not do so when the CTRL pin is in “L” or open.

Set this CTRL pin to “L” or open at power-on. To output 32.768 kHz from the F32K pin, after power-on, set the CTRL pin to “H” more than one sec after.

- F32K (32.768 kHz output) pin

This pin has the function to output-control, outputs 32.768 kHz. When the CTRL pin is in “H”, this pin outputs the 32.768 kHz clock pulse, when the CTRL pin is in “L” or open, the status is in high impedance. This pin has Nch open drain output.

- FOUT (output for clock pulse signal) pin

This pin is to output the clock pulse selected by users. Users can select the frequency by using the FOUT setting register 1 and 2. This pin outputs “L” at power-on. This pin has CMOS output.

- VDD (positive power supply) pin

Connect this VDD pin with a positive power supply. Regarding the values of voltage to be applied, refer to “■ Recommended Operation Conditions”.

- VDDL (positive power supply for FOUT output) pin

This pin is for positive power supply for the FOUT pin's output. Set the value of voltage to be applied as  $V_{DDL} \leq V_{DD}$ .

- VSS pin

Connect this VSS pin to GND.

■ Equivalent Circuits of I/O Pin

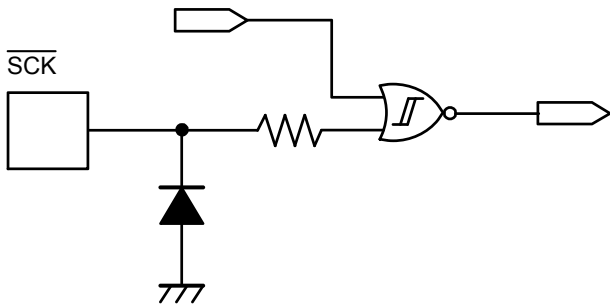

Figure 3  $\overline{\text{SCK}}$  pin

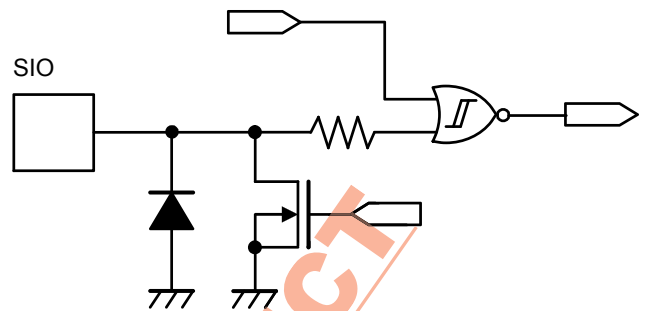

Figure 4 SIO pin

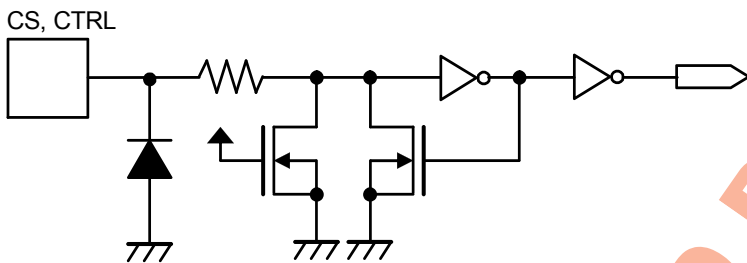

Figure 5 CS pin, CTRL pin

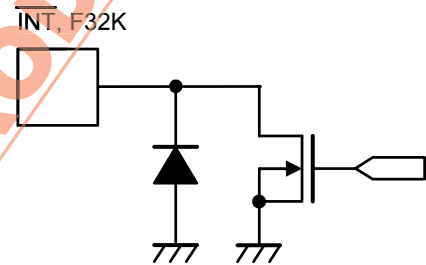

Figure 6  $\overline{\text{INT}}$  pin, F32K pin

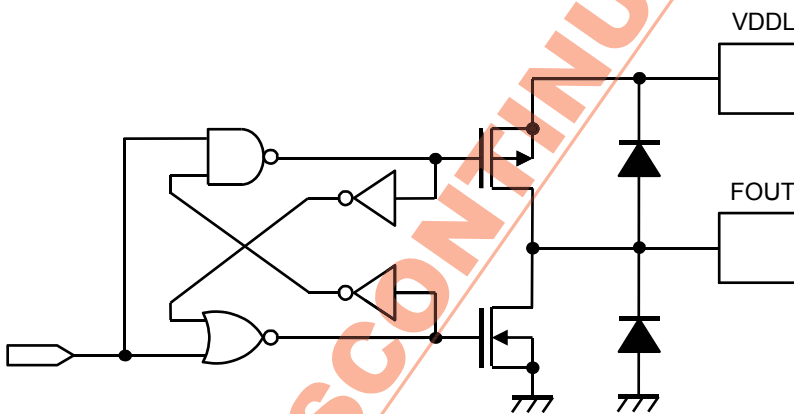

Figure 7 FOUT pin and VDDL pin

DISCONTINUED PRODUCT

■ Block Diagram

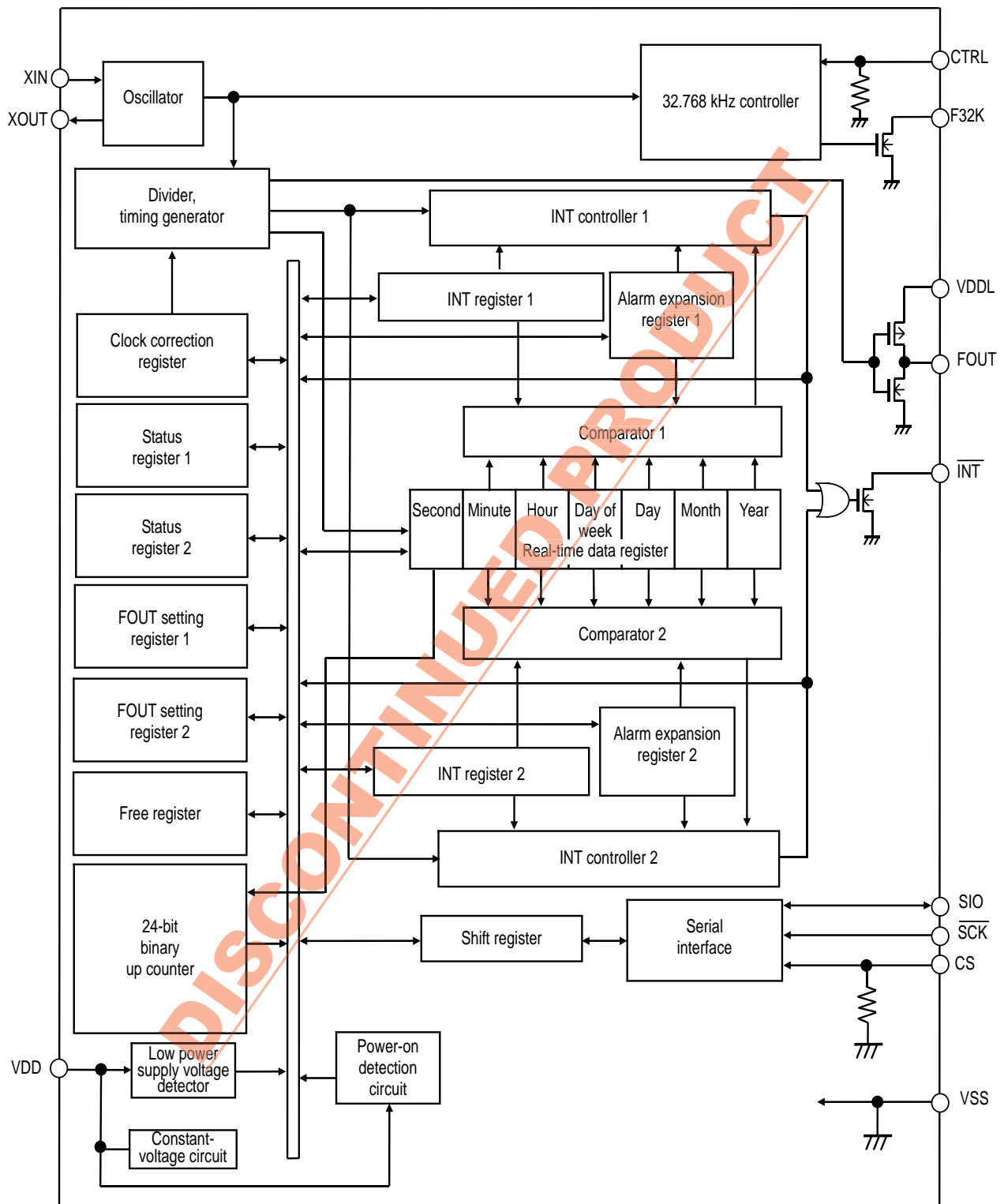

Figure 8

## ■ Absolute Maximum Ratings

Table 2

Parameter	Symbol	Applicable Pin	Rating	Unit
Power supply voltage 1	V <sub>DD</sub>	–	V <sub>SS</sub> – 0.3 to V <sub>SS</sub> + 6.5	V
Power supply voltage 2	V <sub>DDL</sub>	–	V <sub>SS</sub> – 0.3 to V <sub>DD</sub>	V
Input voltage	V <sub>IN</sub>	$\overline{\text{SCK}}$ , SIO, CS, CTRL	V <sub>SS</sub> – 0.3 to V <sub>SS</sub> + 6.5	V
Output voltage 1	V <sub>OUT1</sub>	SIO, $\overline{\text{INT}}$ , F32K	V <sub>SS</sub> – 0.3 to V <sub>SS</sub> + 6.5	V
Output voltage 2	V <sub>OUT2</sub>	FOUT	V <sub>SS</sub> – 0.3 to V <sub>DDL</sub>	V
Operating ambient temperature *1	T <sub>opr</sub>	–	–40 to +85	°C
Storage temperature	T <sub>stg</sub>	–	–55 to +125	°C

\*1. Conditions with no condensation or frost. Condensation and frost cause short circuiting between pins, resulting in a malfunction.

**Caution** The absolute maximum ratings are rated values exceeding which the product could suffer physical damage. These values must therefore not be exceeded under any conditions.

## ■ Recommended Operation Conditions

Table 3

(V<sub>SS</sub> = 0 V)

Parameter	Symbol	Conditions	Min.	Typ.	Max.	Unit
Power supply voltage 1 *1	V <sub>DD</sub>	T <sub>a</sub> = –40 to +85°C	1.3	3.0	5.5	V
Power supply voltage 2	V <sub>DDL</sub>	T <sub>a</sub> = –40 to +85°C	1.3	–	V <sub>DD</sub>	V
Time keeping power supply voltage *2	V <sub>DDT</sub>	T <sub>a</sub> = –40 to +85°C	V <sub>DET</sub> – 0.15	–	5.5	V
Crystal oscillator C <sub>L</sub> value	C <sub>L</sub>	–	–	6	7	pF

\*1. The power supply voltage that allows communication under the conditions shown in Table 8 of “■ AC Electrical Characteristics”.

\*2. The power supply voltage that allows time keeping. For the relationship with V<sub>DET</sub> (low power supply voltage detection voltage), refer to “■ Characteristics (Typical Data)”.

## ■ Oscillation Characteristics

Table 4

(T<sub>a</sub> = 25°C, V<sub>DD</sub> = 3.0 V, V<sub>SS</sub> = 0 V, SP-T2A crystal oscillator (C<sub>L</sub> = 6 pF, 32.768 kHz) manufactured by Seiko Instruments Inc.)

Parameter	Symbol	Conditions	Min.	Typ.	Max.	Unit
Oscillation start voltage	V <sub>STA</sub>	Within 10 seconds	1.1	–	5.5	V
Oscillation start time	t <sub>STA</sub>	CTRL pin = “L” or open	–	–	1	s
IC-to-IC frequency deviation *1	δIC	–	–10	–	+10	ppm
Frequency voltage deviation	δV	V <sub>DD</sub> = 1.3 to 5.5 V	–3	–	+3	ppm/V
External capacitance	C <sub>g</sub>	Applied to XIN pin	–	–	9.1	pF
Internal oscillation capacitance	C <sub>d</sub>	Applied to XOUT pin	–	8	–	pF
Duty ratio	Duty	Applied when 32.768 kHz is output from either $\overline{\text{INT}}$ , F32K, or FOUT pin	40	–	60	%

\*1. Reference value

## ■ DC Electrical Characteristics

**Table 5 DC Characteristics ( $V_{DD} = 3.0\text{ V}$ )**

( $T_a = -40$  to  $+85^\circ\text{C}$ ,  $V_{SS} = 0\text{ V}$ , SP-T2A crystal oscillator ( $C_L = 6\text{ pF}$ ,  $32.768\text{ kHz}$ ,  $C_0 = 9.1\text{ pF}$ ) manufactured by Seiko Instruments Inc.)

Parameter	Symbol	Applicable Pin	Conditions	Min.	Typ.	Max.	Unit
Current consumption 1	$I_{DD1}$	–	Out of communication	–	0.34	0.97	$\mu\text{A}$
Current consumption 2	$I_{DD2}$	–	Out of communication (when 32.768 kHz is output from F32K pin or $\overline{\text{INT}}$ pin)	–	0.60	1.47	$\mu\text{A}$
Current consumption 3	$I_{DD3}$	–	During communication ( $\text{SCK} = 100\text{ kHz}$ )	–	5	8	$\mu\text{A}$
Input current leakage 1	$I_{IZH}$	$\overline{\text{SCK}}$ , SIO	$V_{IN} = V_{DD}$	–0.5	–	0.5	$\mu\text{A}$
Input current leakage 2	$I_{IZL}$	$\overline{\text{SCK}}$ , SIO	$V_{IN} = V_{SS}$	–0.5	–	0.5	$\mu\text{A}$
Input current 1	$I_{IH1}$	CS, CTRL	$V_{IN} = V_{DD}$	2	6	16	$\mu\text{A}$
Input current 2	$I_{IH2}$	CS, CTRL	$V_{IN} = 0.4\text{ V}$	40	100	300	$\mu\text{A}$
Input current 3	$I_{IH3}$	CS, CTRL	$V_{IN} = 1.0\text{ V}$	–	215	–	$\mu\text{A}$
Output current leakage 1	$I_{OZH}$	SIO, $\overline{\text{INT}}$ , F32K	$V_{OUT1} = V_{DD}$	–0.5	–	0.5	$\mu\text{A}$
Output current leakage 2	$I_{OZL}$	SIO, $\overline{\text{INT}}$ , F32K	$V_{OUT1} = V_{SS}$	–0.5	–	0.5	$\mu\text{A}$
Input voltage 1	$V_{IH}$	$\overline{\text{SCK}}$ , SIO, CS, CTRL	–	$0.8 \times V_{DD}$	–	$V_{SS} + 5.5$	V
Input voltage 2	$V_{IL}$	$\overline{\text{SCK}}$ , SIO, CS, CTRL	–	$V_{SS} - 0.3$	–	$0.2 \times V_{DD}$	V
Output current 1	$I_{OL1}$	$\overline{\text{INT}}$ , F32K	$V_{OUT1} = 0.4\text{ V}$	3	5	–	mA
Output current 2	$I_{OL2}$	SIO, FOUT	$V_{OUT1} = V_{OUT2} = 0.4\text{ V}$	5	10	–	mA
Output current 3	$I_{OH}$	FOUT	$V_{OUT2} = V_{DD} - 0.4\text{ V}$	–	–1.5	–1	mA
Power supply voltage detection voltage	$V_{DET}$	–	–	0.65	1	1.35	V

**Table 6 DC Characteristics ( $V_{DD} = 5.0\text{ V}$ )**

( $T_a = -40$  to  $+85^\circ\text{C}$ ,  $V_{SS} = 0\text{ V}$ , SP-T2A crystal oscillator ( $C_L = 6\text{ pF}$ ,  $32.768\text{ kHz}$ ,  $C_0 = 9.1\text{ pF}$ ) manufactured by Seiko Instruments Inc.)

Parameter	Symbol	Applicable Pin	Conditions	Min.	Typ.	Max.	Unit
Current consumption 1	$I_{DD1}$	–	Out of communication	–	0.36	1.18	$\mu\text{A}$
Current consumption 2	$I_{DD2}$	–	Out of communication (when 32.768 kHz is output from F32K pin or $\overline{\text{INT}}$ pin)	–	0.82	2.17	$\mu\text{A}$
Current consumption 3	$I_{DD3}$	–	During communication ( $\overline{\text{SCK}} = 100\text{ kHz}$ )	–	9.3	14	$\mu\text{A}$
Input current leakage 1	$I_{IZH}$	$\overline{\text{SCK}}$ , SIO	$V_{IN} = V_{DD}$	–0.5	–	0.5	$\mu\text{A}$
Input current leakage 2	$I_{IZL}$	$\overline{\text{SCK}}$ , SIO	$V_{IN} = V_{SS}$	–0.5	–	0.5	$\mu\text{A}$
Input current 1	$I_{IH1}$	CS, CTRL	$V_{IN} = V_{DD}$	8	16	50	$\mu\text{A}$
Input current 2	$I_{IH2}$	CS, CTRL	$V_{IN} = 0.4\text{ V}$	40	150	350	$\mu\text{A}$
Input current 3	$I_{IH3}$	CS, CTRL	$V_{IN} = 2.0\text{ V}$	–	610	–	$\mu\text{A}$
Output current leakage 1	$I_{OZH}$	SIO, $\overline{\text{INT}}$ , F32K	$V_{OUT1} = V_{DD}$	–0.5	–	0.5	$\mu\text{A}$
Output current leakage 2	$I_{OZL}$	SIO, $\overline{\text{INT}}$ , F32K	$V_{OUT1} = V_{SS}$	–0.5	–	0.5	$\mu\text{A}$
Input voltage 1	$V_{IH}$	$\overline{\text{SCK}}$ , SIO, CS, CTRL	–	$0.8 \times V_{DD}$	–	$V_{SS} + 5.5$	V
Input voltage 2	$V_{IL}$	$\overline{\text{SCK}}$ , SIO, CS, CTRL	–	$V_{SS} - 0.3$	–	$0.2 \times V_{DD}$	V
Output current 1	$I_{OL1}$	$\overline{\text{INT}}$ , F32K	$V_{OUT1} = 0.4\text{ V}$	5	8	–	mA
Output current 2	$I_{OL2}$	SIO, FOUT	$V_{OUT1} = V_{OUT2} = 0.4\text{ V}$	6	13	–	mA
Output current 3	$I_{OH}$	FOUT	$V_{OUT2} = V_{DD} - 0.4\text{ V}$	–	–2.3	–1.5	mA
Power supply voltage detection voltage	$V_{DET}$	–	–	0.65	1	1.35	V

DISCONTINUED PRODUCT



## ■ AC Electrical Characteristics

Table 7 Measurement Conditions

Input pulse voltage	$V_{IH} = 0.8 \times V_{DD}$ , $V_{IL} = 0.2 \times V_{DD}$
Input pulse rise/fall time	20 ns
Output determination voltage	$V_{OH} = 0.8 \times V_{DD}$ , $V_{OL} = 0.2 \times V_{DD}$
Output load	80 pF + pull-up resistor 10 k $\Omega$

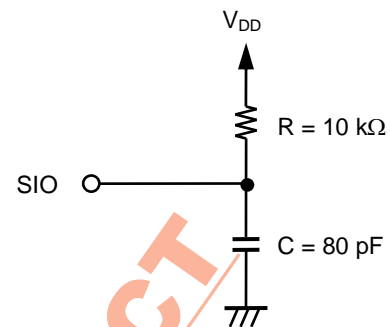

**Remark** The power supplies of the IC and load have the same electrical potential.

Figure 9 Output Load Circuit

Table 8 AC Electrical Characteristics

( $T_a = -40$  to  $+85^\circ\text{C}$ )

Parameter	Symbol	$V_{DD}^{*2} \geq 1.3 \text{ V}$			$V_{DD}^{*2} \geq 3.0 \text{ V}$			Unit
		Min.	Typ.	Max.	Min.	Typ.	Max.	
Clock pulse width	$t_{SCK}$	5	–	250000	1	–	250000	$\mu\text{s}$
Setup time before CS rise	$t_{DS}$	1	–	–	0.2	–	–	$\mu\text{s}$
Hold time after CS rise	$t_{CSH}$	1	–	–	0.2	–	–	$\mu\text{s}$
Input data setup time	$t_{ISU}$	1	–	–	0.2	–	–	$\mu\text{s}$
Input data hold time	$t_{IHO}$	1	–	–	0.2	–	–	$\mu\text{s}$
Output data definition time <sup>*1</sup>	$t_{ACC}$	–	–	3.5	–	–	1	$\mu\text{s}$
Setup time before CS fall	$t_{CSS}$	1	–	–	0.2	–	–	$\mu\text{s}$
Hold time after CS fall	$t_{DH}$	1	–	–	0.2	–	–	$\mu\text{s}$
Input rise/fall time	$t_R, t_F$	–	–	0.1	–	–	0.05	$\mu\text{s}$

\*1. Since the output format of the SIO pin is Nch open-drain output, output data definition time is determined by the values of the load resistance ( $R_L$ ) and load capacity ( $C_L$ ) outside the IC. Therefore, use this value only as a reference value.

\*2. Regarding the power supply voltage, refer to “■ Recommended Operation Conditions”.

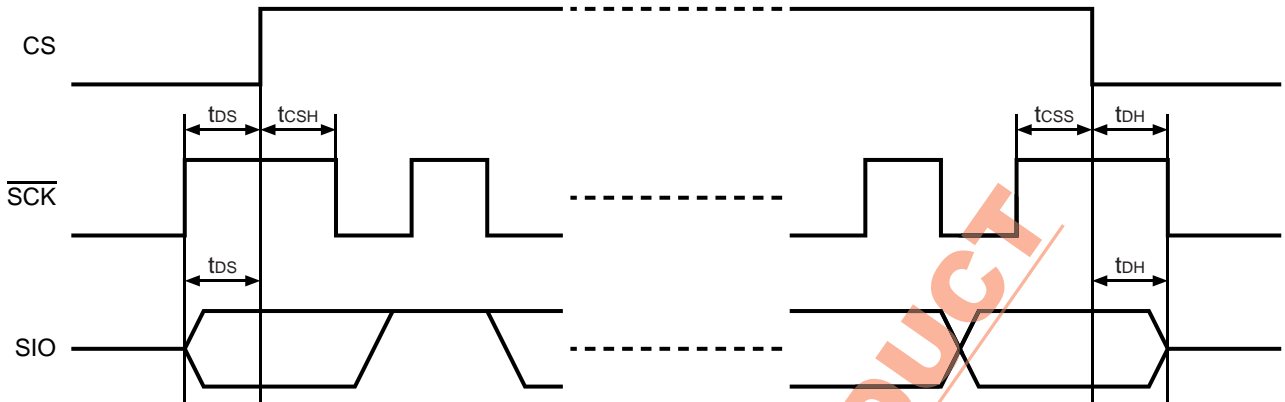

Figure 10 Timing Diagram 1 during 3-wire Communication

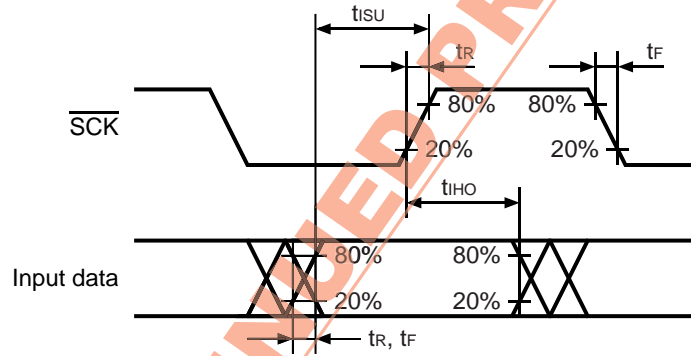

Figure 11 Timing Diagram 2 during 3-wire Communication

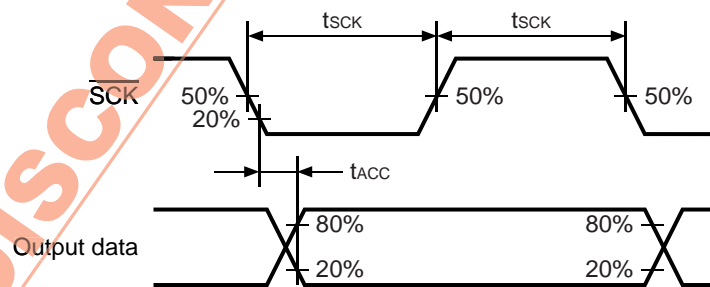

Figure 12 Timing Diagram 3 during 3-wire Communication

■ Configuration of Data Communication

1. Configuration of data communication

After setting the CS pin "H", transmit the 4-bit code "0110" or "0111", after that, transmit a 3-bit command and 1-bit Read/Write command. Next, data is output or input from B7. Regarding details, refer to "■ Serial Interface". Code "0110" is compatible with the SII S-35190A/192A as software. Regarding details, refer to "2. Configuration of command".

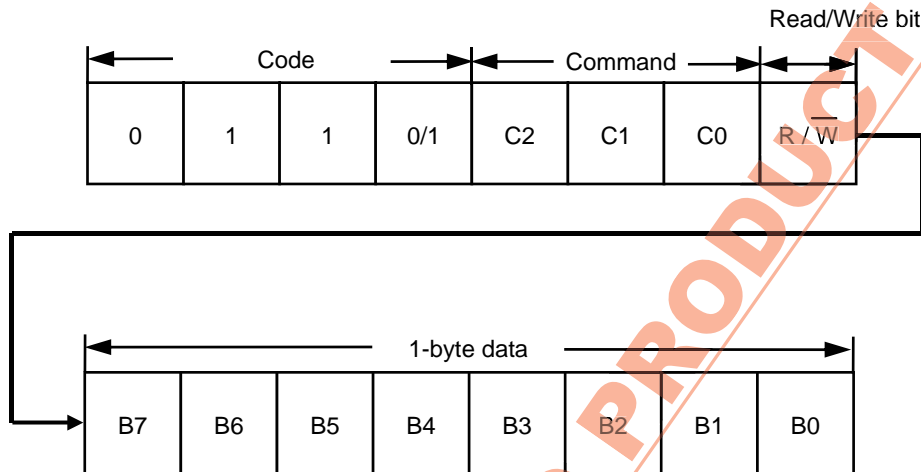

Figure 13 Data Communication

DISCONTINUED PRODUCT

**2. Configuration of command**

13 types of command are available for the S-35199A01, The S-35199A01 does Read/Write the various registers by inputting these codes and commands. The S-35199A01 does not perform any operation with any codes and commands other than those below.

**Table 9 List of Command**

Code	Command			Data								
	C2	C1	C0	Description	B7	B6	B5	B4	B3	B2	B1	B0
0110	0	0	0	Status register 1 access	RESET <sup>*1</sup>	$\overline{12/24}$	SC0 <sup>*2</sup>	SC1 <sup>*2</sup>	INT1 <sup>*3</sup>	INT2 <sup>*3</sup>	BLD <sup>*4</sup>	POC <sup>*4</sup>
	0	0	1	Status register 2 access	INT1FE	INT1ME	INT1AE	32kE	SC2 <sup>*2</sup>	SC3 <sup>*2</sup>	INT2AE	TEST <sup>*5</sup>
	0	1	0	Real-time data 1 access (year data to)	Y1	Y2	Y4	Y8	Y10	Y20	Y40	Y80
					M1	M2	M4	M8	M10	<sup>*6</sup>	<sup>*6</sup>	<sup>*6</sup>
					D1	D2	D4	D8	D10	D20	<sup>*6</sup>	<sup>*6</sup>
					W1	W2	W4	<sup>*6</sup>	<sup>*6</sup>	<sup>*6</sup>	<sup>*6</sup>	<sup>*6</sup>
					H1	H2	H4	H8	H10	H20	AM/PM	<sup>*6</sup>
					m1	m2	m4	m8	m10	m20	m40	<sup>*6</sup>
	s1	s2	s4	s8	s10	s20	s40	<sup>*6</sup>				
	0	1	1	Real-time data 2 access (hour data to)	H1	H2	H4	H8	H10	H20	AM/PM	<sup>*6</sup>
m1					m2	m4	m8	m10	m20	m40	<sup>*6</sup>	
s1					s2	s4	s8	s10	s20	s40	<sup>*6</sup>	
1	0	0	INT register 1 access (alarm time 1: week/hour/minute) (INT1AE = 1, INT1ME = 0, INT1FE = 0)	W1	W2	W4	<sup>*6</sup>	<sup>*6</sup>	<sup>*6</sup>	<sup>*6</sup>	A1WE	
			H1	H2	H4	H8	H10	H20	AM/PM	A1HE		
INT register 1 access (output of user-set frequency) (INT1ME = 0, INT1FE = 1)				1 Hz	2 Hz	4 Hz	8 Hz	16 Hz	SC4 <sup>*2</sup>	SC5 <sup>*2</sup>	SC6 <sup>*2</sup>	
1	0	1	INT register 2 access (alarm time 2: week/hour/minute) (INT2AE = 1)	W1	W2	W4	<sup>*6</sup>	<sup>*6</sup>	<sup>*6</sup>	<sup>*6</sup>	A2WE	
			H1	H2	H4	H8	H10	H20	AM/PM	A2HE		
m1				m2	m4	m8	m10	m20	m40	A2mE		
1	1	0	Clock-correction register access	V0	V1	V2	V3	V4	V5	V6	V7	
1	1	1	Free register access	F0	F1	F2	F3	F4	F5	F6	F7	
0111	0	0	Up counter access <sup>*7</sup>	C64k	C128k	C256k	C512k	C1M	C2M	C4M	C8M	
				C256	C512	C1k	C2k	C4k	C8k	C16k	C32k	
				C1	C2	C4	C8	C16	C32	C64	C128	
	0	0	1	FOUT setting register 1 access	256 Hz	512 Hz	1 kHz	2 kHz	4 kHz	8 kHz	16 kHz	32 kHz
	0	1	0	FOUT setting register 2 access	1 Hz	2 Hz	4 Hz	8 Hz	16 Hz	32 Hz	64 Hz	128 Hz
	1	0	0	Alarm expansion register 1 access (alarm time 1 : year/month/day)	Y1	Y2	Y4	Y8	Y10	Y20	Y40	Y80
M1				M2	M4	M8	M10	<sup>*6</sup>	A1YE	A1ME		
D1				D2	D4	D8	D10	D20	<sup>*6</sup>	A1DE		
1	0	1	Alarm expansion register 2 access (alarm time 2 : year/month/day)	Y1	Y2	Y4	Y8	Y10	Y20	Y40	Y80	
			M1	M2	M4	M8	M10	<sup>*6</sup>	A2YE	A2ME		
D1				D2	D4	D8	D10	D20	<sup>*6</sup>	A2DE		

- \*1. Write-only flag. The S-35199A01 initializes by writing "1" in this register.
- \*2. Scratch bit. A R/W-enabled, user-free register.
- \*3. Read-only flag. Valid only when using the alarm function. When the alarm time matches, this flag is set to "1", and it is cleared to "0" when Read.
- \*4. Read-only flag. "POC" is set to "1" when power is applied. It is cleared to "0" when Read. Regarding "BLD", refer to "■ Low Power Supply Voltage Detection Circuit".
- \*5. Test bit for SII. Be sure to set "0" in use.
- \*6. No effect by Write. It is "0" when Read.
- \*7. The up counter is a Read-only register.

■ Configuration of Register

1. Real-time data register

The real-time data register is a 7-byte register that stores the data of year, month, day, day of the week, hour, minute, and second in the BCD code. To Write/Read real-time data 1 access, transmit/receive the data of year in B7, month, day, day of the week, hour, minute, second in B0, in 7-byte. When you skip the procedure to access the data of year, month, day, day of the week, Read/Write real-time data 2 access. In this case, transmit/receive the data of hour in B7, minute, second in B0, in 3-byte.

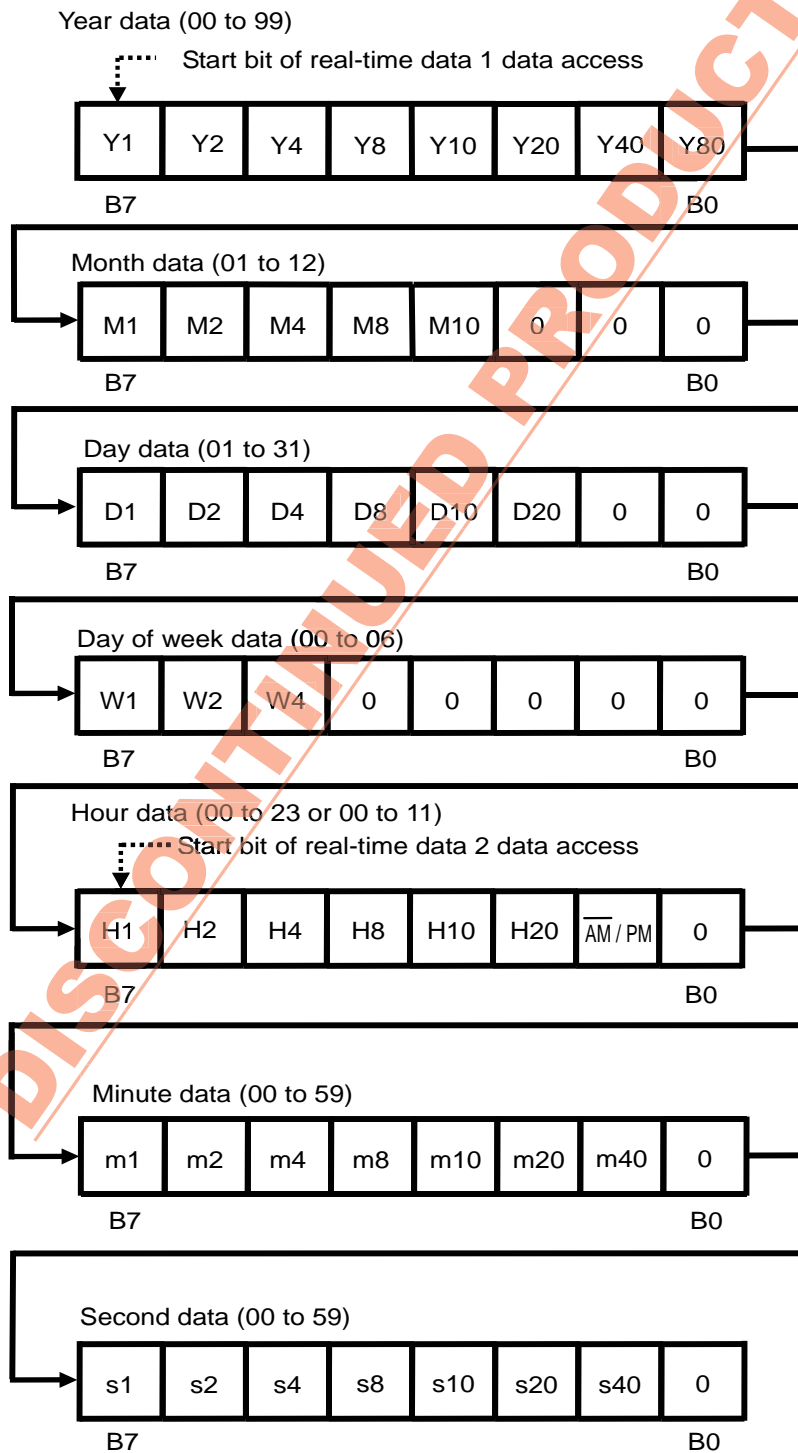

Figure 14 Real-time Data Register

**Year data (00 to 99): Y1, Y2, Y4, Y8, Y10, Y20, Y40, Y80**

Sets the lower two digits in the Western calendar year (00 to 99) and links together with the auto calendar function until 2099.

Example: 2053 (Y1, Y2, Y4, Y8, Y10, Y20, Y40, Y80) = (1, 1, 0, 0, 1, 0, 1, 0)

**Month data (01 to 12): M1, M2, M4, M8, M10**

Example: December (M1, M2, M4, M8, M10, 0, 0, 0) = (0, 1, 0, 0, 1, 0, 0, 0)

**Day data (01 to 31): D1, D2, D4, D8, D10, D20**

The count value is automatically changed by the auto calendar function.

1 to 31: Jan., Mar., May, July, Aug., Oct., Dec., 1 to 30: April, June, Sep., Nov.

1 to 29: Feb. (leap year), 1 to 28: Feb. (non-leap year)

Example: 29 (D1, D2, D4, D8, D10, D20, 0, 0) = (1, 0, 0, 1, 0, 1, 0, 0)

**Day of the week data (00 to 06): W1, W2, W4**

A septenary up counter. Day of the week is counted in the order of 00, 01, 02, ..., 06, and 00. Set up day of the week and the count value.

**Hour data (00 to 23 or 00 to 11): H1, H2, H4, H8, H10, H20, AM / PM**

In a 12-hour expression, write 0; AM, 1; PM in the  $\overline{\text{AM/PM}}$  bit. In a 24-hour expression, users can Write either 0 or 1. 0 is read when the hour data is from 00 to 11, and 1 is read when from 12 to 23.

Example (12-hour expression): 12 p.m. (H1, H2, H4, H8, H10, H20, AM/PM, 0) = (0, 1, 0, 0, 1, 0, 1, 0)

Example (24-hour expression): 22 (H1, H2, H4, H8, H10, H20, AM/PM, 0) = (0, 1, 0, 0, 0, 1, 1, 0)

**Minute data (00 to 59): m1, m2, m4, m8, m10, m20, m40**

Example: 32 minutes (m1, m2, m4, m8, m10, m20, m40, 0) = (0, 1, 0, 0, 1, 1, 0, 0)

Example: 55 minutes (m1, m2, m4, m8, m10, m20, m40, 0) = (1, 0, 1, 0, 1, 0, 1, 0)

**Second data (00 to 59): s1, s2, s4, s8, s10, s20, s40**

Example: 19 seconds (s1, s2, s4, s8, s10, s20, s40, 0) = (1, 0, 0, 1, 1, 0, 0, 0)

DISCONTINUED PRODUCT

## 2. Status register 1

Status register 1 is a 1-byte register that is used to display and set various modes. The bit configuration is shown below.

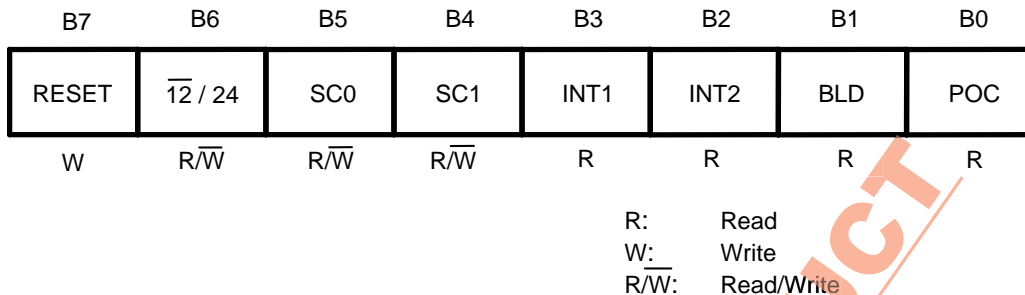

Figure 15 Status Register 1

### B0 : POC

This flag is used to confirm whether the power is on. The power-on detection circuit operates at power-on and B0 is set to "1". This flag is Read-only. Once it is read, it is automatically set to "0". When this flag is "1", be sure to initialize. Regarding the operation after power-on, refer to "■ Power-on Detection Circuit and Register Status".

### B1 : BLD

This flag is set to "1" when the power supply voltage decreases to the level of detection voltage ( $V_{DET}$ ) or less. Users can detect a drop in the power supply voltage. This flag is set to "1" once, is not set to "0" again even if the power supply increases to the level of detection voltage ( $V_{DET}$ ) or more. This flag is Read-only. When this flag is "1", be sure to initialize. Regarding the operation of the power supply voltage detection circuit, refer to "■ Low Power Supply Voltage Detection Circuit".

### B2, B3 : INT2, INT1

This flag indicates the time set by alarm and when the time has reached it. This flag is set to "1" when the time that users set by using the alarm interrupt function has come. The INT1 flag in "1" at alarm 1 interrupt mode, the INT2 flag in "1" at alarm 2 interrupt mode. Set "0" in INT1AE (B5 in the status register 2) or in INT2AE (B1 in the status register 2) after reading "1" in the INT1 flag or in the INT2 flag. This flag is Read-only. This flag is read once, is set to "0" automatically.

### B4, B5 : SC1, SC0

These are 2-bit SRAM type registers that can be freely set by users.

### B6 : $\overline{12/24}$

This flag is used to set 12-hour or 24-hour expression.

- 0 : 12-hour expression
- 1 : 24-hour expression

### B7 : RESET

The internal IC is initialized by setting this bit to "1". This bit is Write-only. It is always "0" when Read. When applying the power supply voltage to the IC, be sure to write "1" to this bit to initialize the circuit. Regarding each status of data after initialization, refer to "■ Register Status After Initialization".

### 3. Status Register 2

Status register 2 is a 1-byte register that is used to display and set various modes. The bit configuration is shown below.

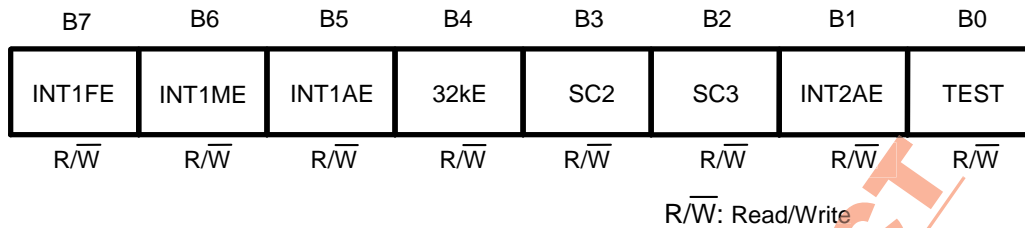

Figure 16 Status Register 2

#### B0 : TEST

This is a test flag for SII. Be sure to set this flag to "0" in use. If this flag is set to "1", be sure to initialize to set "0".

#### B1 : INT2AE

This is an enable bit for alarm 2 interrupt. When this bit is "0", alarm 2 interrupt is disabled. When it is "1", it is enabled. To use alarm 2 interrupt, access the INT register 2 and the alarm expansion register 2 after enabling this flag.

**Caution** Note that alarm 2 interrupt is output from the  $\overline{\text{INT}}$  pin regardless of the settings in flags B4 to B7.

#### B2, B3 : SC3, SC2

These are 2-bit SRAM type registers that can be freely set by users.

#### B4 : 32kE, B5 : INT1AE, B6 : INT1ME, B7 : INT1FE

These bits are used to select the output mode for the  $\overline{\text{INT}}$  pin. Table 10 shows how to select the mode. To use alarm 1 interrupt, access the INT register 1 and the alarm expansion register 1, after setting the alarm 1 interrupt mode.

Table 10 Output Modes for  $\overline{\text{INT}}$  Pin

32kE	INT1AE	INT1ME	INT1FE	$\overline{\text{INT}}$ Pin Output Mode
0	0	0	0	No interrupt
0	-*1	0	1	Output of user-set frequency
0	-*1	1	0	Per-minute edge interrupt
0	0	1	1	Minute-periodical interrupt 1 (50% duty)
0	1	0	0	Alarm 1 interrupt
0	1	1	1	Minute-periodical interrupt 2
1	-*1	-*1	-*1	32.768 kHz output

\*1. Don't care (Both of 0 and 1 are acceptable).



4. INT register 1 and INT register 2

The INT register 1 is to set up the output of user-set frequency, or to set up alarm 1 interrupt. The INT register 2 is for setting alarm 2 interrupt. Users are able to switch the output mode by using the status register 2. If selecting to use the output mode for alarm interrupt by status register 2; this register works as the alarm-time data register. In the INT register 1, if selecting the output of user-set frequency by status register 2; this register works as the data register to set the frequency for clock output. From the INT pin, a clock pulse and alarm interrupt are output, according to the or-condition that these two registers have.

(1) Alarm interrupt

Users can set the alarm time (the data of day of the week, hour, minute) by using the INT register 1 and 2 which are 3-byte data registers. The configuration of register is as well as the data register of day of the week, hour, minute, in the real-time data register; is expressed by the BCD code. Do not set a nonexistent day. Users are necessary to set up the alarm-time data according to the 12/24 hour expression that they set by using the status register 1.

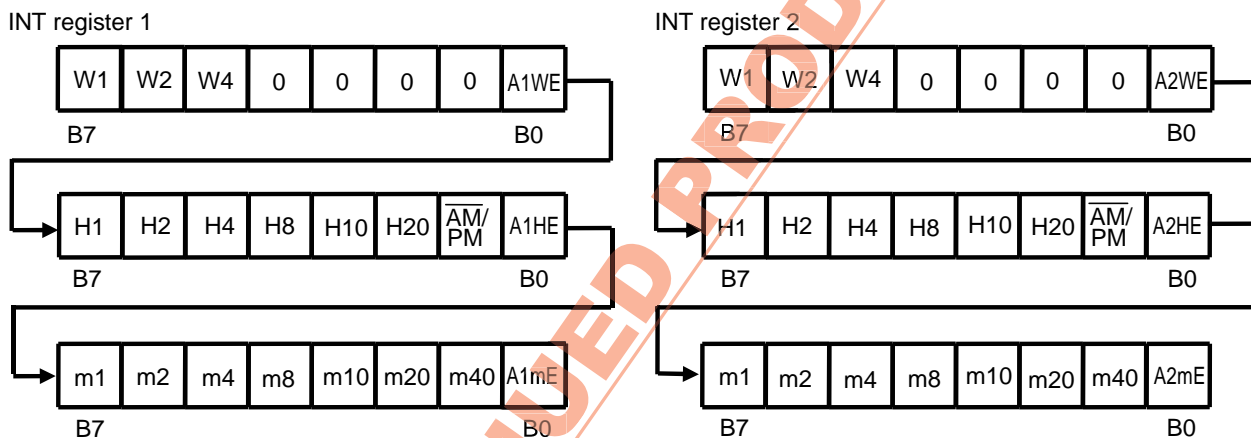

Figure 17 INT Register 1 and 2 (Alarm-Time Data)

The INT register 1 has A1WE, A1HE, A1mE at B0 in each byte. It is possible to make data valid; the data of day of the week, hour, minute which are in the corresponded byte; by setting these bits to "1". This is as well in A2WE, A2HE, A2mE in the INT register 2. Regarding set-up of year, month, day, refer to "9. Alarm expansion register 1 and alarm expansion register 2".

Setting example: alarm time "7:00 pm" in the INT register 1

(a) 12-hour expression (status register 1 B6 = 0)

set up 7:00 PM

Data written to INT register 1

Day of week	_*1	_*1	_*1	_*1	_*1	_*1	_*1	0	
Hour	1	1	1	0	0	0	1	1	
Minute	0	0	0	0	0	0	0	1	
	B7							B0	

\*1. Don't care (Both of 0 and 1 are acceptable).

(b) 24-hour expression (status register 1 B6 = 1)

set up 19:00 PM

Data written to INT register 1

Day of week	_*1	_*1	_*1	_*1	_*1	_*1	_*1	0	
Hour	1	0	0	1	1	0	1*2	1	
Minute	0	0	0	0	0	0	0	1	
	B7							B0	

\*1. Don't care (Both of 0 and 1 are acceptable).

\*2. Set up AM/PM flag along with the time setting.

**(2) Output of user-set frequency**

The INT register 1 is a 1-byte data register to set up the output frequency. Setting each bit B7 to B3 in the register to “1”, the frequency which corresponds to the bit is output in the AND-form. SC4 to SC6 is 3-bit SRAM type registers that can be freely set by users.

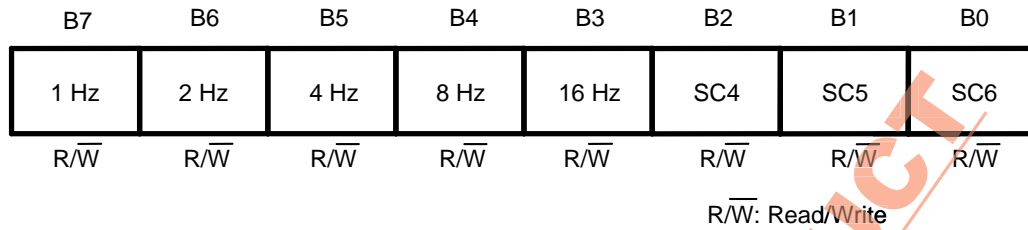

**Figure 18 INT Register 1 (Data register for output frequency)**

**Example:** B7 to B3 = 50h

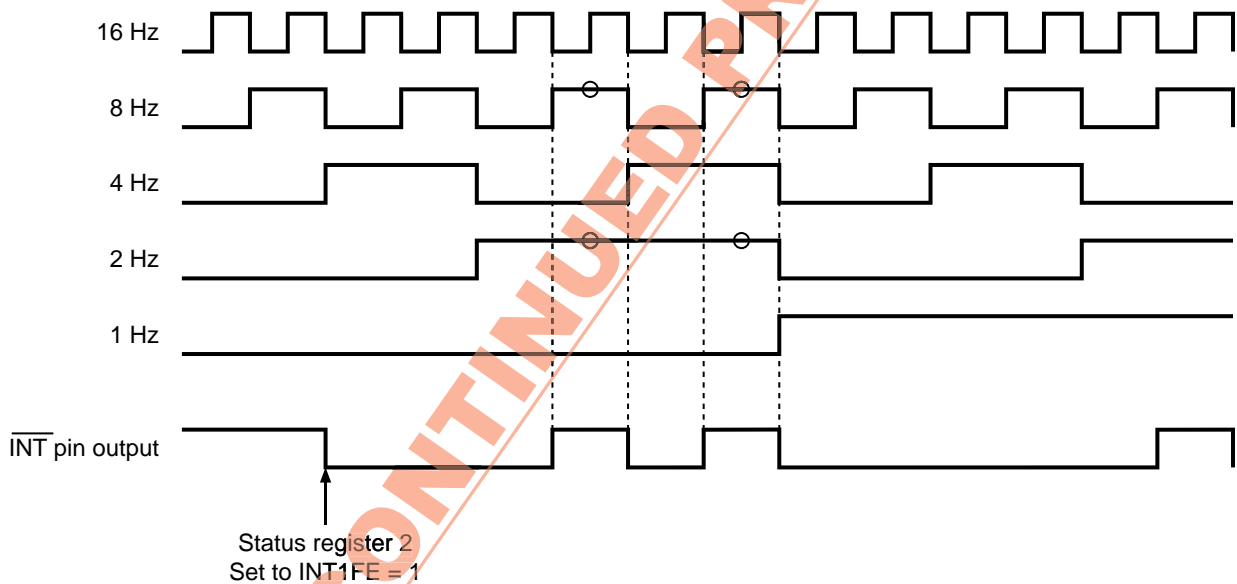

**Figure 19 Example of output from INT register 1 (Data register for output frequency)**

### 5. Clock-correction register

The clock-correction register is a 1-byte register that is used to correct advance/delay of the clock. When not using this function, set this register to "00h". Regarding the register values, refer to "■ Function to Clock-Correction".

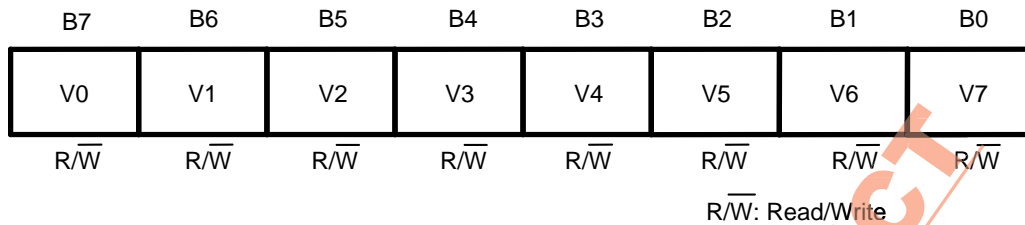

Figure 20 Clock-Correction Register

### 6. Free register

The free register is a 1-byte SRAM type register that can be set freely by users.

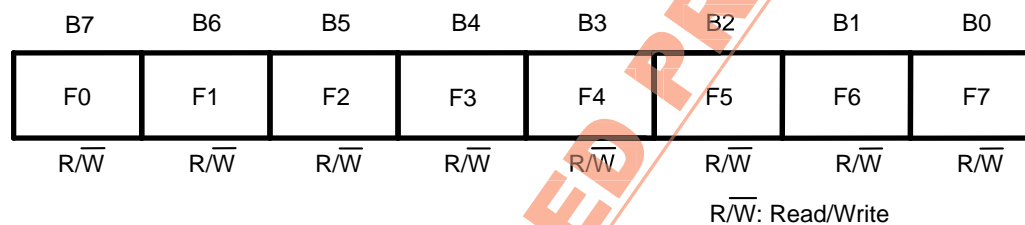

Figure 21 Free Register

### 7. Up counter

The up counter is a 24-bit Read-only register. It starts binary counting from “000000h” from power-on and continues counting as long as power is being applied. It continues counting when initialization, instead of returning to “000000h”. At power-on, registers are cleared by the power-on detection circuit so that the up counter is cleared to “000000h”. If the power-on detection circuit does not operate successfully, the counter may start from the indefinite status. For successful operation of the power-on detection circuit, refer to “■ Power-on Detection Circuit and Register Status”. Regarding the operation timing of the up counter, refer to “■ Up-Count Operation”.

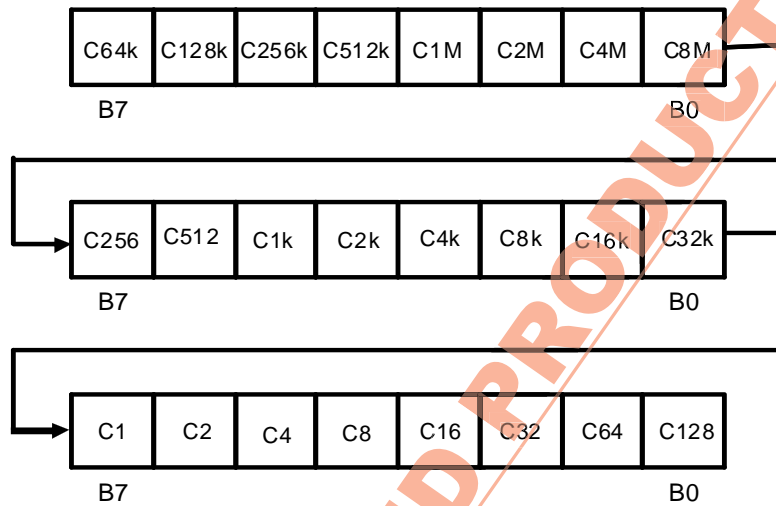

Figure 22 Up Counter

Table 11 Example of Count Value and Read Data in Register

Count Value	Read data in register
000001h	000080h
000002h	000040h
•	•
•	•
•	•
FFFFFFh	F7FFFFh
•	•
•	•
•	•
FFFFFFh	FFFFFFh

8. FOUT setting register 1 and FOUT setting register 2

FOUT setting register 1 and 2 are 1-byte data registers to set up the output frequency for the FOUT pin. As well as the function output of user-set frequency, in the INT register 1, by setting each bit in the register to "1", the frequency, which corresponds to the bit, is output in the AND-form. **Figure 25** shows the setting example. At power-on, the FOUT setting register 1 and 2 are set to "00h" so that no clock pulses are output. The value of output voltage is defined by  $V_{DDL}$ .

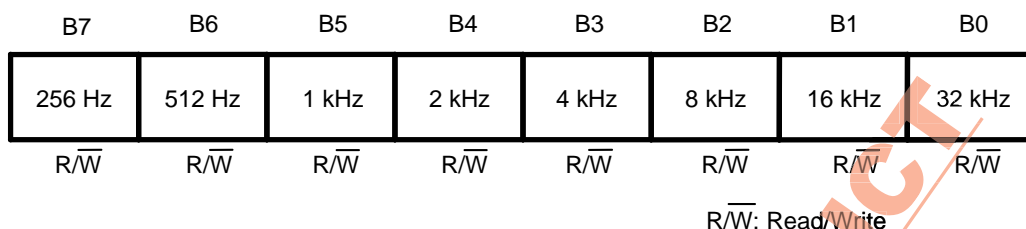

Figure 23 FOUT Setting Register 1

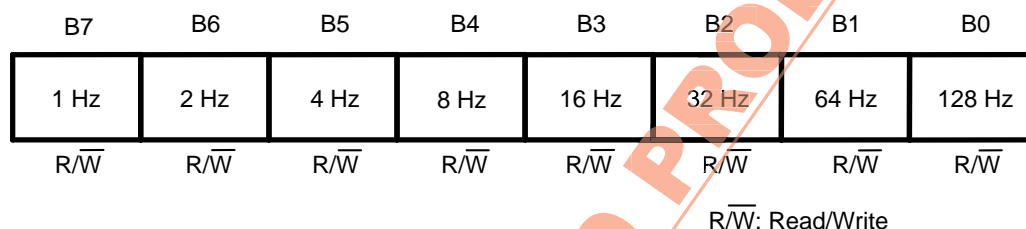
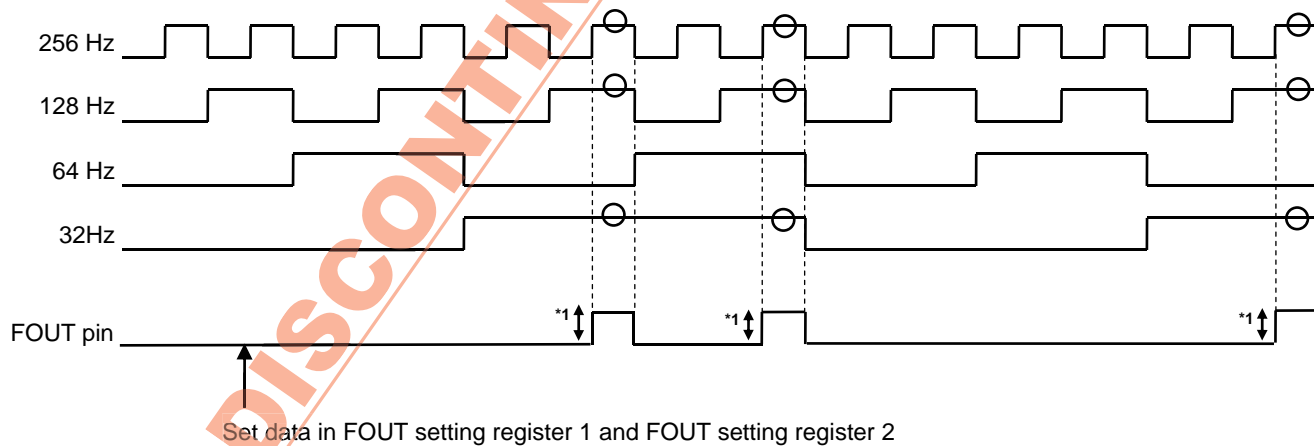

Figure 24 FOUT Setting Register 2

**Setting example:** FOUT setting register 1 : B7 to B0 = 80h,  
FOUT setting register 2 : B7 to B0 = 05h



\*1. The value of output voltage is defined by  $V_{DDL}$ . Set  $V_{DDL} \leq V_{DD}$ .

Figure 25 Example of output of clock pulse

**9. Alarm expansion register 1 and alarm expansion register 2**

The alarm expansion register 1 and 2 are 3-byte registers. They are expansion registers for the INT register 1 and 2 which output alarm interrupt. Users are able to set the alarm time; the data of year, month, day. The configuration of register is expressed by BCD code as well as the data register of year, month, day in the real-time register.

Alarm expansion register 1

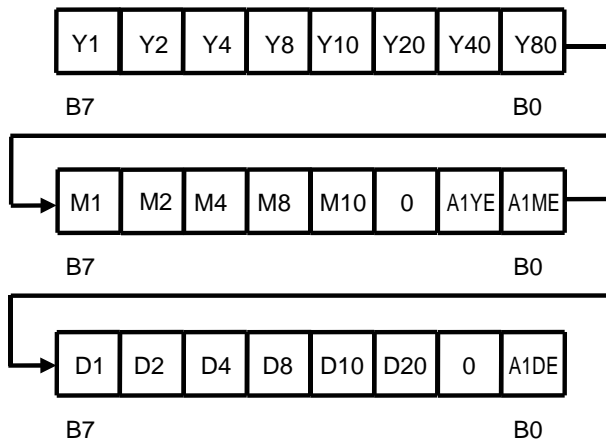

Alarm expansion register 2

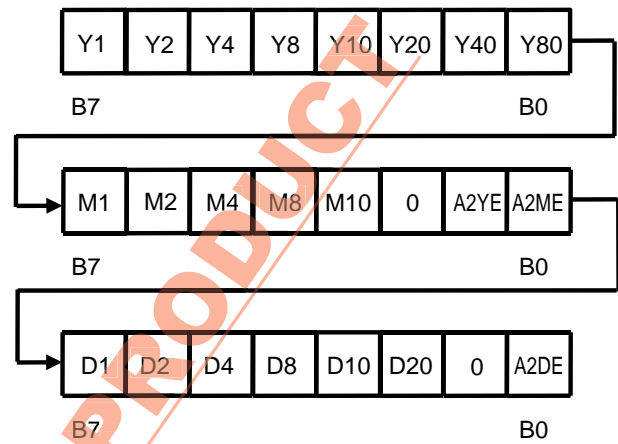

**Figure 26 Alarm Expansion Register 1, Alarm Expansion Register 2**

To make the year data of alarm expansion register 1 valid, set A1YE to "1". For the month data, set A1ME to "1", for the day data, set A1DE to "1". Set as well A2ME, A2YE, A2DE in the alarm expansion register 2. Regarding how to set the data of day of the week, hour, and minute, refer to "(1) Alarm interrupt" in "4. INT register 1 and INT register 2".

**Setting example:** Setting alarm time "January 31, 2015" in the alarm expansion register 1

Data written to the alarm expansion register 1

Year	1	0	1	0	1	0	0	0
Month	1	0	0	0	0	*1	1	1
Day	1	0	0	0	1	1	*1	1
	B7				B0			

\*1. Don't care (Both of 0 and 1 are acceptable.)

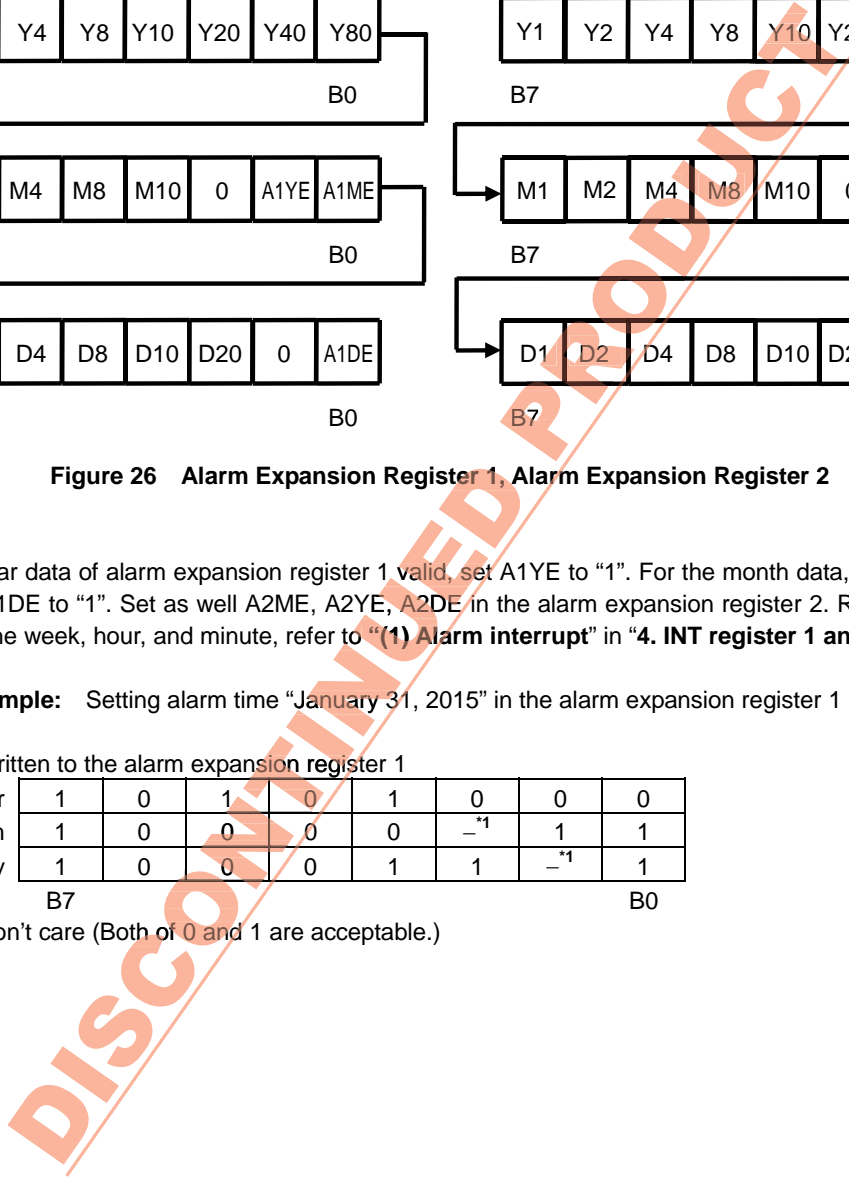

## ■ Power-on Detection Circuit and Register Status

The power-on detection circuit operates by power-on the S-35199A01, as a result each register is cleared; each register is set as follows.

Real-time data register :	00 (Y), 01 (M), 01 (D), 0 (day of the week), 00 (H), 00 (M), 00 (S)
Status register 1 :	"01h"
Status register 2 :	"80h"
INT register 1 :	"80h"
INT register 2 :	"00h"
Clock correction register :	"00h"
Free register :	"00h"
Up counter :	"00 00 00h"
FOUT setting register 1 :	"00h"
FOUT setting register 2 :	"00h"
Alarm expansion register 1 :	"00h"
Alarm expansion register 2 :	"00h"

"1" is set in the POC flag (B0 in the status register 1) to indicate that power has been applied. To correct the oscillation frequency, the status register 2 goes in the mode the output of user-set frequency, so that 1 Hz clock pulse is output from the  $\overline{\text{INT}}$  pin. When "1" is set in the POC flag, be sure to initialize. The POC flag is set to "0" due to initialization so that the output of user-set frequency mode is cleared. (Refer to "■ Register Status After Initialization".)

For the regular operation of power-on detection circuit, the period to power-up the S-35199A01 is that the voltage reaches 1.3 V within 10 ms after setting the IC's power supply voltage at 0 V. When the power-on detection circuit is not working normally is; the POC flag (B0 in the status register) is not in "1", or 1 Hz is not output from the INT pin. In this case, power-on the S-35199A01 once again because the internal data may be in the indefinite status.

Do not transmit data immediately after power-on at least one sec because the power-on detection circuit is operating.

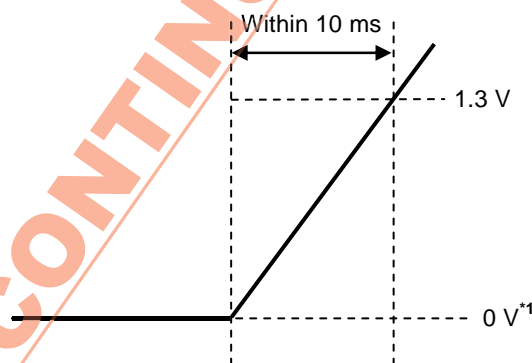

\*1. 0 V indicates that there are no potential differences between the VDD pin and VSS pin of the S-35199A01.

Figure 27 How to raise the power supply voltage

### ■ Register Status After Initialization

The status of each register after initialization is as follows.

Real-time data register :	00 (Y), 01 (M), 01 (D), 0 (day of the week), 00 (H), 00 (M), 00 (S)
Status register 1 :	"0 B6 B5 B4 0 0 0 0 b" (In B6, B5, B4, the data of B6, B5, B6 in the status register 1 at initialization is set. Refer to <b>Figure 28.</b> )
Status register 2 :	"00h"
INT register 1 :	"00h"
INT register 2 :	"00h"
Clock correction register :	"00h"
Free register :	"00h"
Up counter :	Is not initialized and continues counting.
FOUT setting register 1 :	"00h"
FOUT setting register 2 :	"00h"
Alarm expansion register 1 :	"00h"
Alarm expansion register 2 :	"00h"

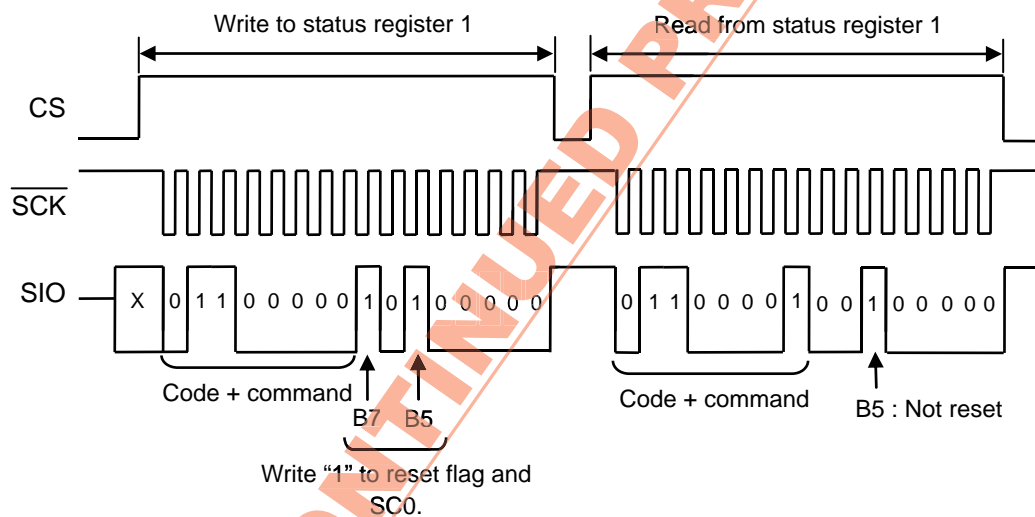

Figure 28 Data of Status Register 1 at Initialization



■ Low Power Supply Voltage Detection Circuit

The S-35199A01 has a low power supply voltage detection circuit, so that users can monitor drops in the power supply voltage by reading the BLD flag (B1 in the status register 1). There is a hysteresis width of approx. 0.15 V (Typ.) between detection voltage and release voltage (refer to “■ Characteristics (Typical Data)”). The low power supply voltage detection circuit does the sampling operation only once in one sec for 15.6 ms.

If the power supply voltage decreases to the level of detection voltage ( $V_{DET}$ ) or less, “1” is set to the BLD flag so that sampling operation stops. Once “1” is detected in the BLD flag, no sampling operation is performed even if the power supply voltage increases to the level of release voltage or more, and “1” is held in the BLD flag. After initialization, or once the BLD flag is read, the BLD flag is automatically set to “0” to restart the sampling operation.

If the BLD flag is “1” even after the power supply voltage is recovered, the internal circuit may be in the indefinite status. In this case, be sure to initialize the circuit.

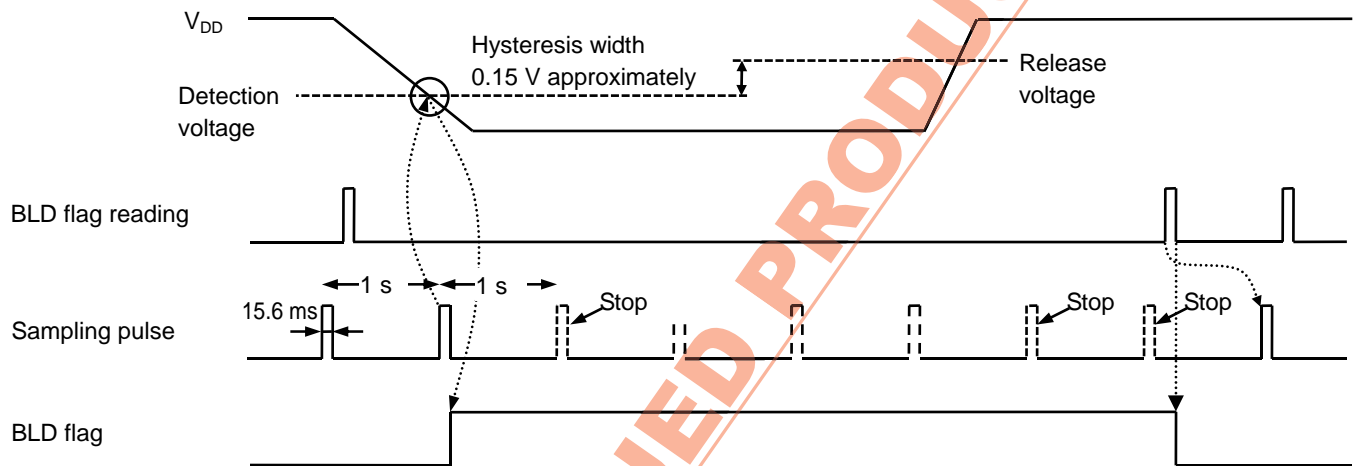

Figure 29 Timing of Low Power Supply Voltage Detection Circuit

■ Circuits Power-on and Low Power Supply Voltage Detection

Figure 30 shows the changes of the POC flag and BLD flag due to  $V_{DD}$  fluctuation.

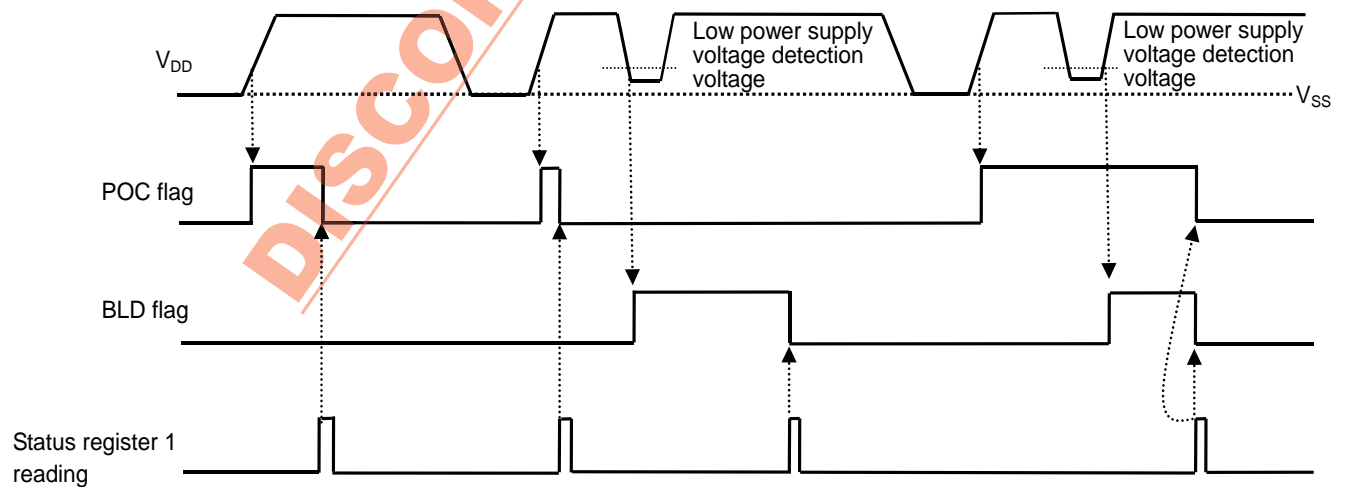

Figure 30 POC Flag and BLD Flag

■ **Correction of Nonexistent Data and End-of-Month**

When users write the real-time data, the S-35199A01 checks it. In case that the data is invalid, the S-35199A01 does the following procedures.

**1. Processing of nonexistent data**

**Table 12 Processing of Nonexistent Data**

Register	Normal Data	Nonexistent Data	Result
Year data	00 to 99	XA to XF, AX to FX	00
Month data	01 to 12	00, 13 to 19, XA to XF	01
Day data	01 to 31	00, 32 to 39, XA to XF	01
Day of week data	0 to 6	7	0
Hour data *1	24-hour	0 to 23	24 to 29, 3X, XA to XF
	12-hour	0 to 11	12 to 20, XA to XF
Minute data	00 to 59	60 to 79, XA to XF	00
Second data **2	00 to 59	60 to 79, XA to XF	00

- \*1. In a 12-hour expression, Write the AM/PM flag (B1 in hour data in the real-time data register).  
In 24-hour expression, the AM/PM flag in the real-time data register is omitted. However in the flag in Read, users are able to read 0; 0 to 11, 1; 12 to 23.
- \*2. Processing of nonexistent data, regarding second data, is done by a carry pulse which is generated one sec after, after Write. At this point the carry pulse is sent to the minute-counter.

**2. Correction of end-of-month**

A nonexistent day, such as February 30 and April 31, is set to the first day of the next month.

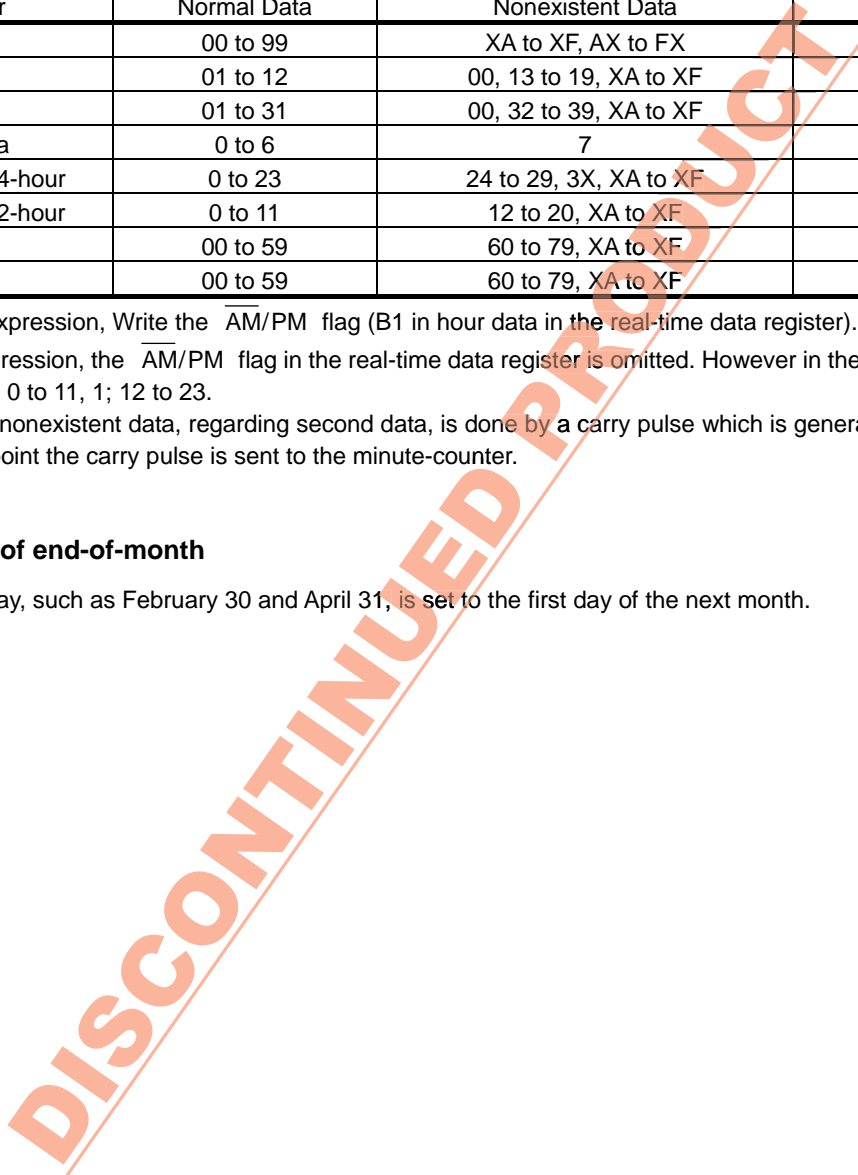

**■ INT Pin Output Mode**

These are selectable for the INT pin output mode;

Alarm 1 interrupt, alarm 2 interrupt, the output of user-set frequency, per-minute edge interrupt output, minute-periodical interrupt output 1 and 2, 32.768 kHz output.

In alarm 1 interrupt/output of frequency; set data in the INT register 1. In alarm 2 interrupt, set data in the INT register 2. To switch the output mode, use the status register 2. Refer to “3. status register 2” in “■ Configuration of Register”.

When switching the output mode, be careful of the output status of the pin. Especially, when using alarm interrupt/output of frequency, switch the output mode after setting “00h” in the INT register 1 or 2. Alarm 2 interrupt is dependent from other modes. Regardless of other settings of mode if alarm 2 interrupt was generated, be careful that “L” is output from the INT pin. In 32.768 kHz output/per-minute edge interrupt output/minute-periodical interrupt output, it is unnecessary to set data in the INT register 1 or 2 for users.

Refer to the followings regarding each operation of output modes.

**1. Alarm interrupt output**

Alarm interrupt output is the function to output “L” from the INT pin, at the alarm time which is set by user has come. If setting the pin output to “H”, turn off the alarm function by setting “0” in INT1AE/INT2AE in the status register 2.

To set the alarm time, set the data of day of the week, hour, minute in the INT register 1 or 2, set the data of year, month, day in the alarm expansion register 1 or 2. Refer to “4. INT register 1 and INT register 2” and “9. Alarm expansion register 1 and alarm expansion register 2” in “■ Configuration of Register”.

Alarm setting of “Y (year), M (month), D (day), W (day of the week), H (hour), m (minute)”

- |  |   |
|--|---|
| <p>Status register 2 setting</p> <ul style="list-style-type: none"> <li>• Alarm 1 interrupt<br/>32kE = 0, INT1ME = INT1FE = 0</li> <li>• Alarm 2 interrupt<br/>None</li> </ul> | <p>INT register x alarm enable flag</p> <ul style="list-style-type: none"> <li>• AxHE = AxmE = AxWE = “1”</li> </ul> <p>Alarm expansion register x alarm enable flag</p> <ul style="list-style-type: none"> <li>• AxYE = AxME = AxDE = “1”</li> </ul> |
|--|---|

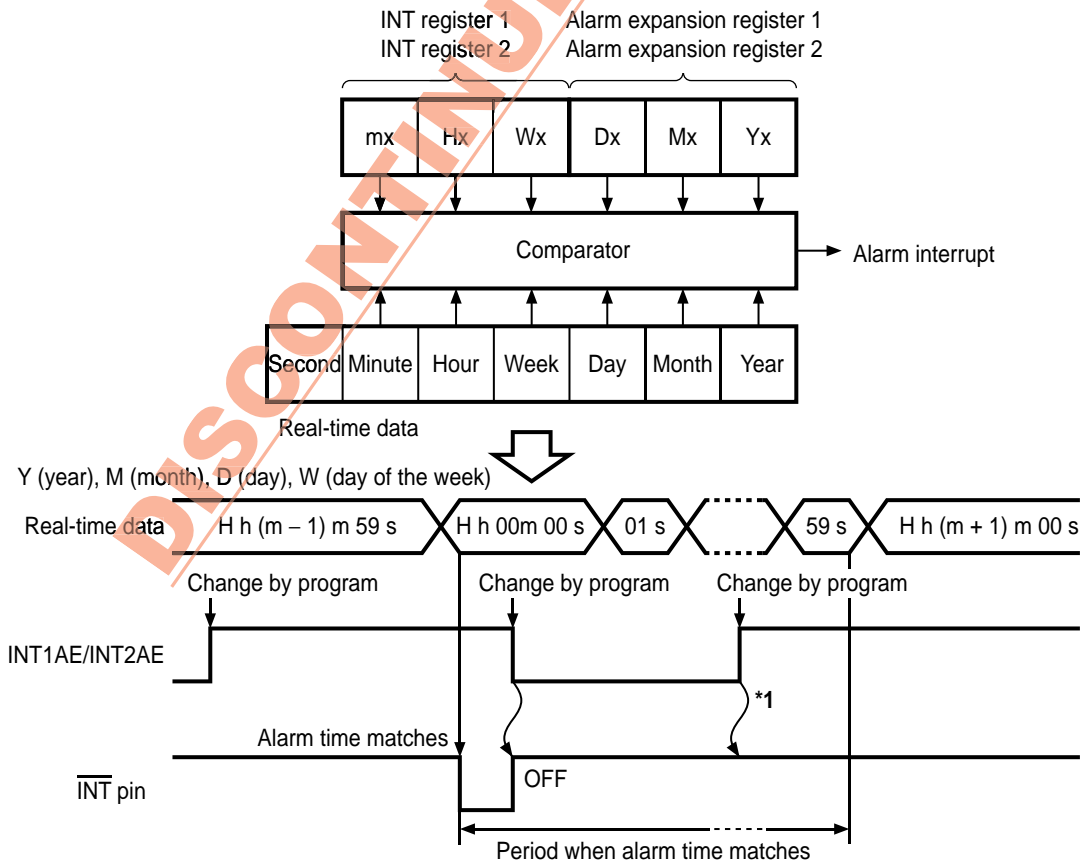

\*1. If Users clear INT1AE/INT2AE once; “L” is not output from the INT pin by setting INT1AE/INT2AE enable again, within a period when the alarm time matches real-time data.

**Figure 31 Alarm Interrupt Output Timing (1/2)**  
Seiko Instruments Inc.

Alarm setting of "H (hour)"

Status register 2 setting

- Alarm 1 interrupt  
32kE = 0, INT1ME = INT1FE = 0
- Alarm 2 interrupt  
None

INT register x alarm enable flag

- AxHE = AxmE = AxWE = "1"
- Alarm expansion register x alarm enable flag
- AxYE = AxME = AxDE = "1"

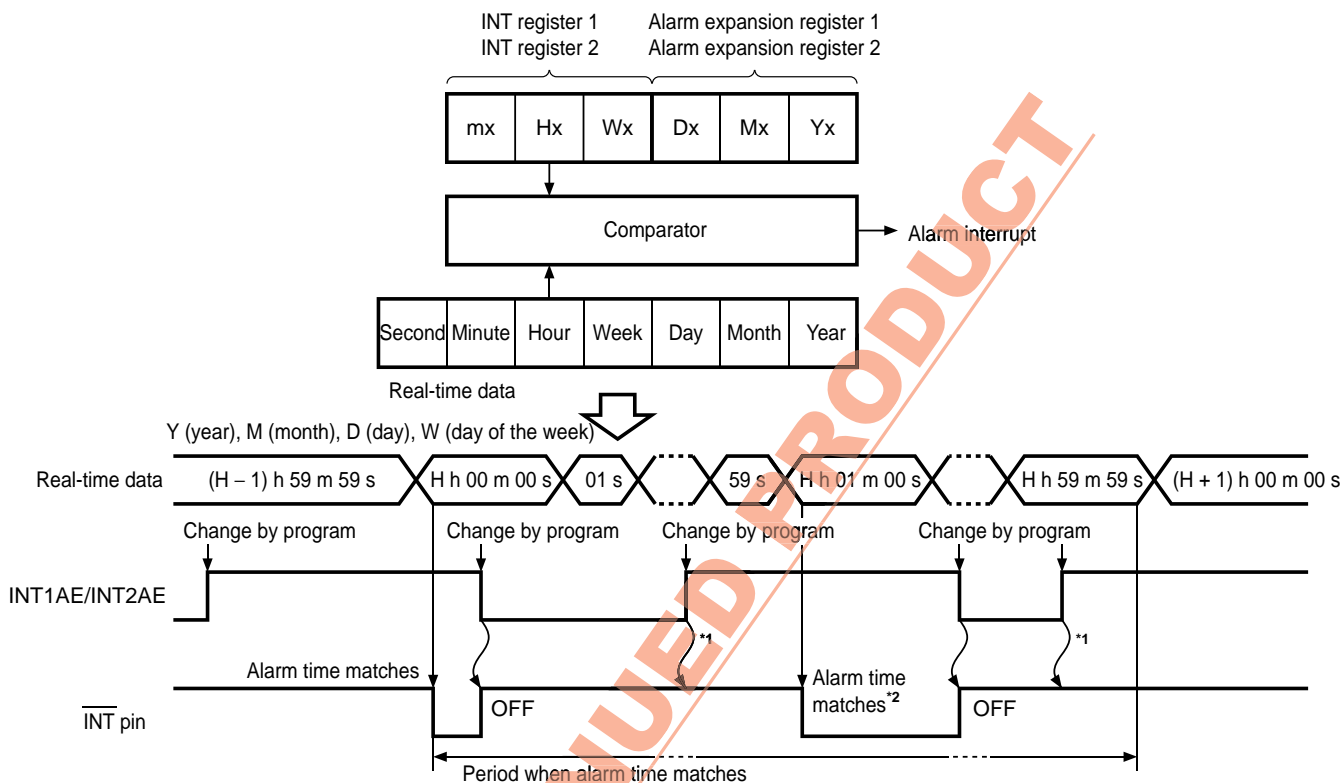

- \*1. If Users clear INT1AE/INT2AE once; "L" is not output from the  $\overline{\text{INT}}$  pin by setting INT1AE/INT2AE enable again, within a period when the alarm time matches real-time data.
- \*2. If turning the alarm output on by changing the program, within the period when the alarm time matches real-time data, "L" is output again from the  $\overline{\text{INT}}$  pin when the minute is counted up.

**Figure 32 Output Timing of Alarm Interrupt (2/2)**

**2. Output of user-set frequency**

The output of user-set frequency is the function to output the frequency which is selected by using data, from the INT pin, in the AND-form. Set up the data of frequency in the INT register 1.

Refer to "4. INT register 1 and INT register 2" in "■ Configuration of Register".

Status register 2 setting

32kE = 0, INT1AE = Don't care (0 or 1), INT1ME = 0

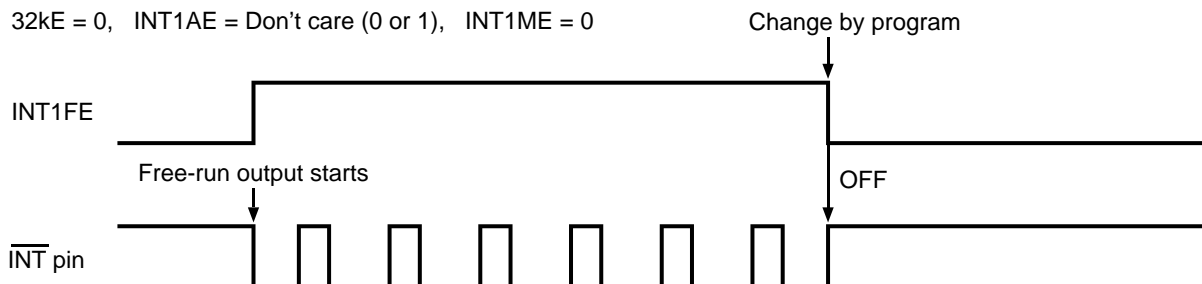

**Figure 33 Output Timing of User-set Frequency**

### 3. Per-minute edge interrupt output

Per-minute edge interrupt output is the function to output "L" from the  $\overline{\text{INT}}$  pin, when the first minute-carry processing is done, after selecting the output mode. To set the pin output to "H", set "0" in INT1ME in the status register 2 to turn off the output mode of per-minute edge interrupt.

Status register 2 setting

- 32kE = 0, INT1AE = Don't care (0 or 1), INT1FE = 0

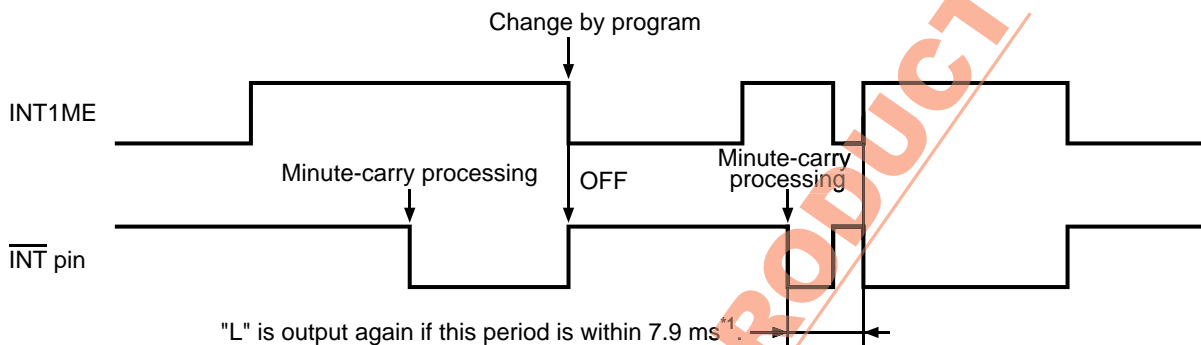

\*1. Pin output is set to "H" by disabling the output mode within 7.9 ms, because the signal of this procedure is maintained for 7.9 ms. Note that pin output is set to "L" by setting enable the output mode again.

Figure 34 Timing of Per-Minute Edge Interrupt Output

### 4. Minute-periodical interrupt output 1

The minute-periodical interrupt 1 is the function to output the one-minute clock pulse (Duty 50%) from the  $\overline{\text{INT}}$  pin, when the first minute-carry processing is done, after selecting the output mode.

Status register 2 setting

- 32kE = 0, INT1AE = 0

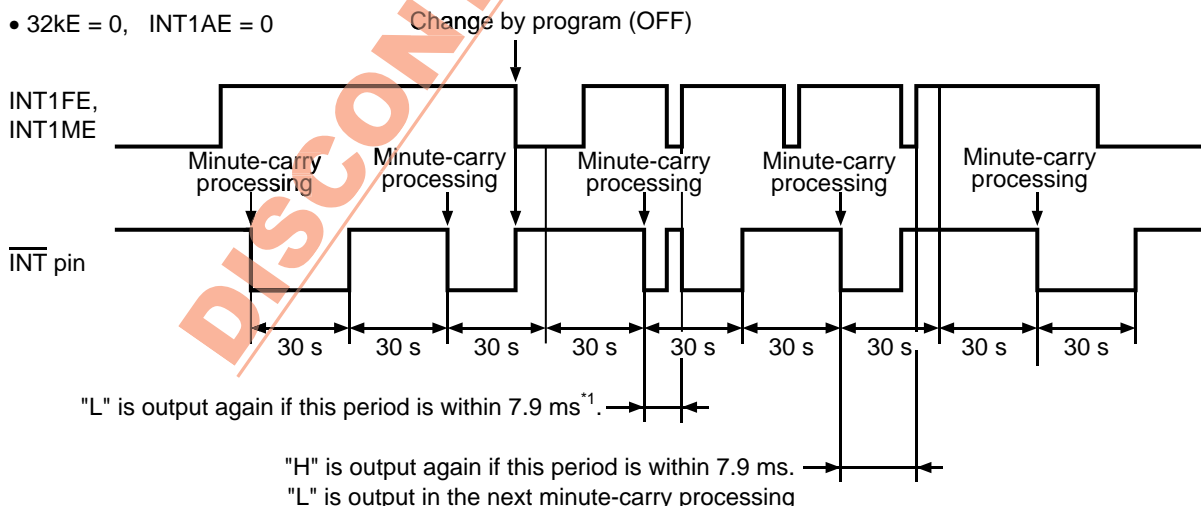

\*1. Setting the output mode disable makes the pin output "H", while the output from the  $\overline{\text{INT}}$  pin is in "L". Note that pin output is set to "L" by setting enable the output mode again.

Figure 35 Timing of Minute-periodical Interrupt Output 1

5. Minute-periodical interrupt output 2

The output of minute-periodical interrupt 2 is the function to output "L", for 7.9 ms, from the  $\overline{\text{INT}}$  pin, synchronizing with the first minute-carry processing after selecting the output mode. However, in Read in the real-time data register, the procedure delays at max. 0.5 sec thus output "L" from the  $\overline{\text{INT}}$  pin also delays at max. 0.5 sec. In Write in the real-time data register, some delay is made in the output period due to Write timing and the second-data during Write.

(a) During normal operation

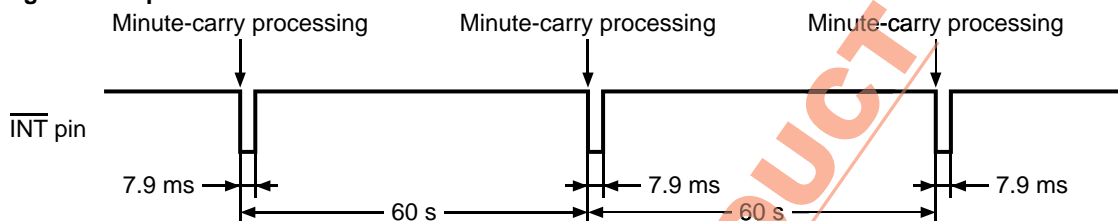

(b) During Read in the real-time data

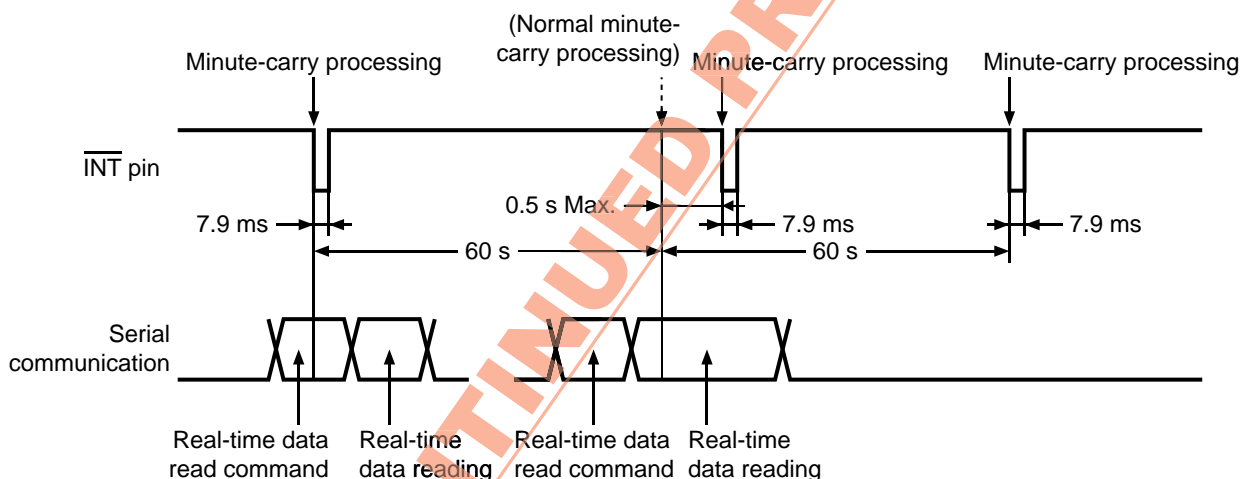

(c) During Write in the real-time data

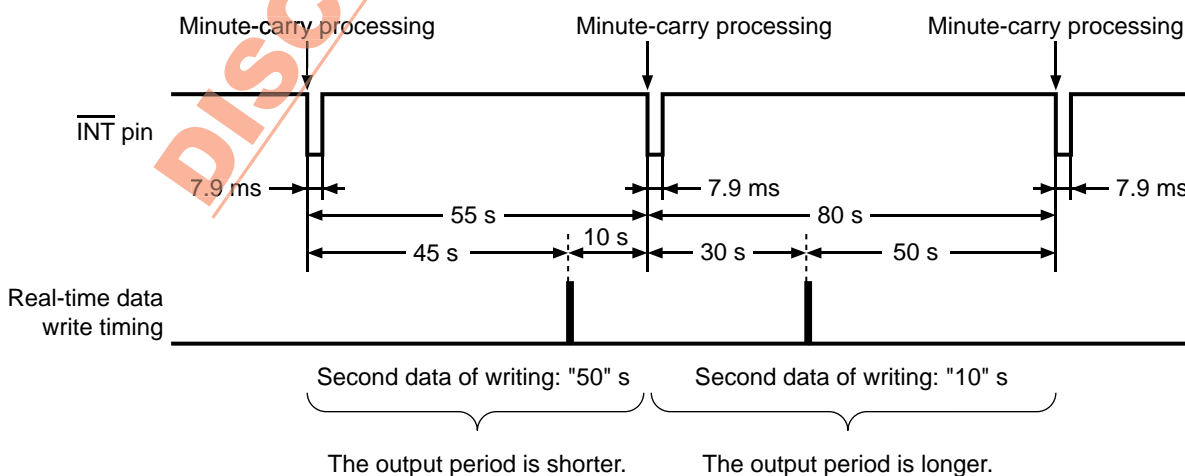

Figure 36 Timing of Minute-periodical Interrupt Output 2

## 6. Operation of power-on detection circuit

When power is applied to the S-35199A01, the power-on detection operates to set “1” in the POC flag (B0 in the status register 1). A 1 Hz clock pulse is output from the  $\overline{\text{INT}}$  pin.

Status register 2 setting

- INT1AE = INT1ME = 0, 32kE = 0

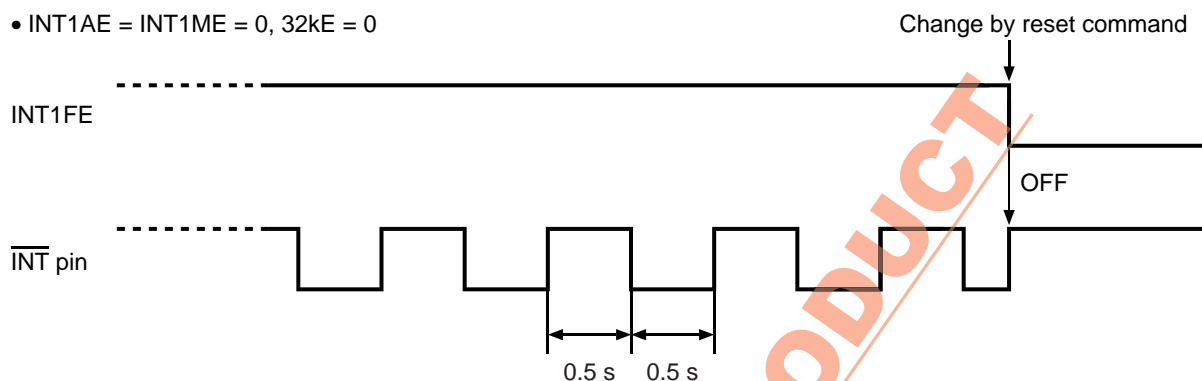

Figure 37 Output Timing of  $\overline{\text{INT}}$  Pin during Operation of Power-on Detection Circuit

## ■ Function to Clock-Correction

The function to clock-correction is to correct advance/delay of the clock due to the deviation of oscillation frequency, in order to make a high precise clock. For correction, the S-35199A01 adjusts the clock pulse by using a certain part of the dividing circuit, not adjusting the frequency of the crystal oscillator. Correction is performed once every 20 seconds (or 60 seconds). The minimum resolution is approx. 3 ppm (or approx. 1 ppm) and the S-35199A01 corrects in the range of  $-195.3$  to  $+192.2$  ppm (or of  $-65.1$  to  $+64.1$  ppm). (Refer to **Table 13.**) Users can set up this function by using the clock-correction register. Regarding how to calculate the setting data, refer to “**1. How to calculate**”. When not using this function, be sure to set “00h”.

Table 13 Function to Clock-Correction

	B0 = 0	B0 = 1
Correction	Every 20 seconds	Every 60 seconds
Minimum resolution	3.052 ppm	1.017 ppm
Correction range	$-195.3$ to $+192.2$ ppm	$-65.1$ to $+64.1$ ppm

## 1. How to calculate

### (1) If current oscillation frequency > target frequency (in case the clock is fast)

$$\text{Correction value}^{*1} = 128 - \text{Integral value} \left( \frac{(\text{Current oscillation frequency actual measurement value}^{*2}) - (\text{Target oscillation frequency}^{*3})}{(\text{Current oscillation frequency actual measurement value}^{*2}) \times (\text{Minimum resolution}^{*4})} \right)$$

**Caution** The figure range which can be corrected is that the calculated value is from 0 to 64.

- \*1. Convert this value to be set in the clock correction register. For how to convert, refer to “(a) Calculation example 1”.
- \*2. Measurement value when 1 Hz clock pulse is output from the  $\overline{\text{INT}}$  pin.
- \*3. Target value of average frequency when the clock correction function is used.
- \*4. Refer to **Table 13**.

#### (a) Calculation example 1

In case of current oscillation frequency actual measurement value = 1.000070 Hz, target oscillation frequency = 1.000000 Hz, B0 = 0 (Minimum resolution = 3.052 ppm)

$$\begin{aligned} \text{Correction value} &= 128 - \text{Integral value} \left( \frac{(1.000070) - (1.000000)}{(1.000070) \times (3.052 \times 10^{-6})} \right) \\ &= 128 - \text{Integral value} (22.93) = 128 - 22 = 106 \end{aligned}$$

Convert the correction value “106” to 7-bit binary and obtain “1101010b”.

Reverse the correction value “1101010b” and set it to B7 to B1 of the clock correction register.

Thus, set the clock correction register:

(B7, B6, B5, B4, B3, B2, B1, B0) = (0, 1, 0, 1, 0, 1, 1, 0)

### (2) If current oscillation frequency < target frequency (in case the clock is slow)

$$\text{Correction value} = \text{Integral value} \left( \frac{(\text{Target oscillation frequency}) - (\text{Current oscillation frequency actual measurement value})}{(\text{Current oscillation frequency actual measurement value}) \times (\text{Minimum resolution})} \right) + 1$$

**Caution** The figure range which can be corrected is that the calculated value is from 0 to 62.

#### (a) Calculation example 2

In case of current oscillation frequency actual measurement value = 0.999920 [Hz], target oscillation frequency = 1.000000 [Hz]. B0 = 0 (Minimum resolution = 3.052 ppm)

$$\begin{aligned} \text{Correction value} &= \text{Integral value} \left( \frac{(1.000000) - (0.999920)}{(0.999920) \times (3.052 \times 10^{-6})} \right) + 1 \\ &= \text{Integral value} (26.21) + 1 = 26 + 1 = 27 \end{aligned}$$

Thus, set the clock correction register:

(B7, B6, B5, B4, B3, B2, B1, B0) = (1, 1, 0, 1, 1, 0, 0, 0)

#### (b) Calculation example 3

In case of current oscillation frequency actual measurement value = 0.999920 [Hz], target oscillation frequency = 1.000000 [Hz], B0 = 1 (Minimum resolution = 1.017 ppm)

$$\begin{aligned} \text{Correction value} &= \text{Integral value} \left( \frac{(1.000000) - (0.999920)}{(0.999920) \times (1.017 \times 10^{-6})} \right) + 1 \\ &= \text{Integral value} (78.66) + 1 \end{aligned}$$

This calculated value exceeds the correctable range 0 to 62.

B0 = “1” (minimum resolution = 1.017 ppm) indicates the correction is impossible.



2. Setting value for register and correction value

Table 14 Setting Value for Register and Correction Value (Minimum Resolution: 3.052 ppm (B0 = 0))

B7	B6	B5	B4	B3	B2	B1	B0	Correction Value [ppm]	Rate [s/day]
1	1	1	1	1	1	0	0	192.3	16.61
0	1	1	1	1	1	0	0	189.2	16.35
1	0	1	1	1	1	0	0	186.2	16.09
⋮								⋮	⋮
0	1	0	0	0	0	0	0	6.1	0.53
1	0	0	0	0	0	0	0	3.1	0.26
0	0	0	0	0	0	0	0	0	0
1	1	1	1	1	1	1	0	-3.1	-0.26
0	1	1	1	1	1	1	0	-6.1	-0.53
1	0	1	1	1	1	1	0	-9.2	-0.79
⋮								⋮	⋮
0	1	0	0	0	0	1	0	-189.2	-16.35
1	0	0	0	0	0	1	0	-192.3	-16.61
0	0	0	0	0	0	1	0	-195.3	-16.88

Table 15 Setting Value for Register and Correction Value (Minimum Resolution: 1.017 ppm (B0 = 1))

B7	B6	B5	B4	B3	B2	B1	B0	Correction Value [ppm]	Rate [s/day]
1	1	1	1	1	1	0	1	64.1	5.54
0	1	1	1	1	1	0	1	63.1	5.45
1	0	1	1	1	1	0	1	62.0	5.36
⋮								⋮	⋮
0	1	0	0	0	0	0	1	2.0	0.18
1	0	0	0	0	0	0	1	1.0	0.09
0	0	0	0	0	0	0	1	0	0
1	1	1	1	1	1	1	1	-1.0	-0.09
0	1	1	1	1	1	1	1	-2.0	-0.18
1	0	1	1	1	1	1	1	-3.0	-0.26
⋮								⋮	⋮
0	1	0	0	0	0	1	1	-63.1	-5.45
1	0	0	0	0	0	1	1	-64.1	-5.54
0	0	0	0	0	0	1	1	-65.1	-5.62

**3. How to confirm setting value for register and result of correction**

The S-35199A01 does not adjust the frequency of the crystal oscillation by using the clock-correction function. Therefore users cannot confirm if it is corrected or not by measuring output 32.768 kHz. When the function to clock-correction is being used, the cycle of 1 Hz clock pulse output from the INT pin changes once in 20 times or 60 times, as shown in Figure 38.

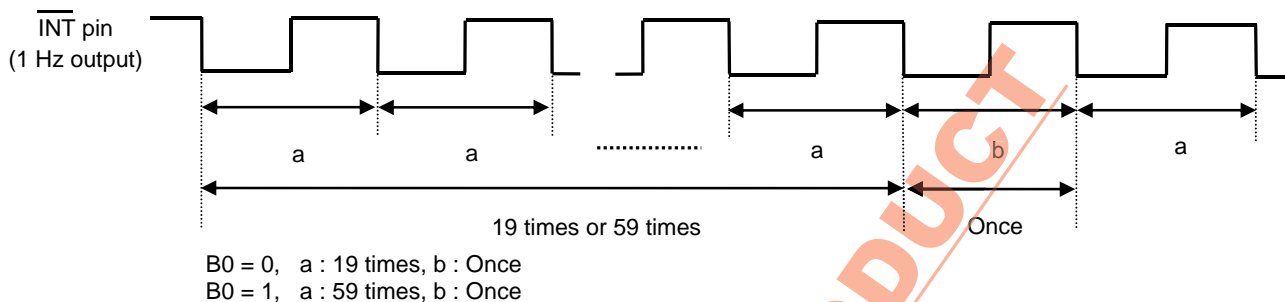

**Figure 38 Confirmation of Correction Result**

Measure a and b by using the frequency counter<sup>\*1</sup>. Calculate the average frequency (Tave) based on the measurement results.

$B0 = 0, Tave = (a \times 19 + b) \div 20$

$B0 = 1, Tave = (a \times 59 + b) \div 60$

Calculate the error of the clock based on the average frequency (Tave). The following shows an example for confirmation.

Confirmation example: When B0 =0, 66h is set

Measurement results: a = 1.000080 Hz, b = 0.998493 Hz

	Clock Correction Register Setting Value	Average frequency [Hz]	Per Day [s]
Before correction	00 h (Tave = a)	1.000080	86393
After correction	66 h (Tave = (a × 19 + b) ÷ 20)	1.00000065	86399.9

Calculating the average frequency allows to confirm the result of correction.

\*1. Use a high-accuracy frequency counter of 7 digits or more.

- Caution**
1. Clock pulse output from the FOUT pin is not corrected.
  2. Measure the oscillation frequency under the usage conditions.

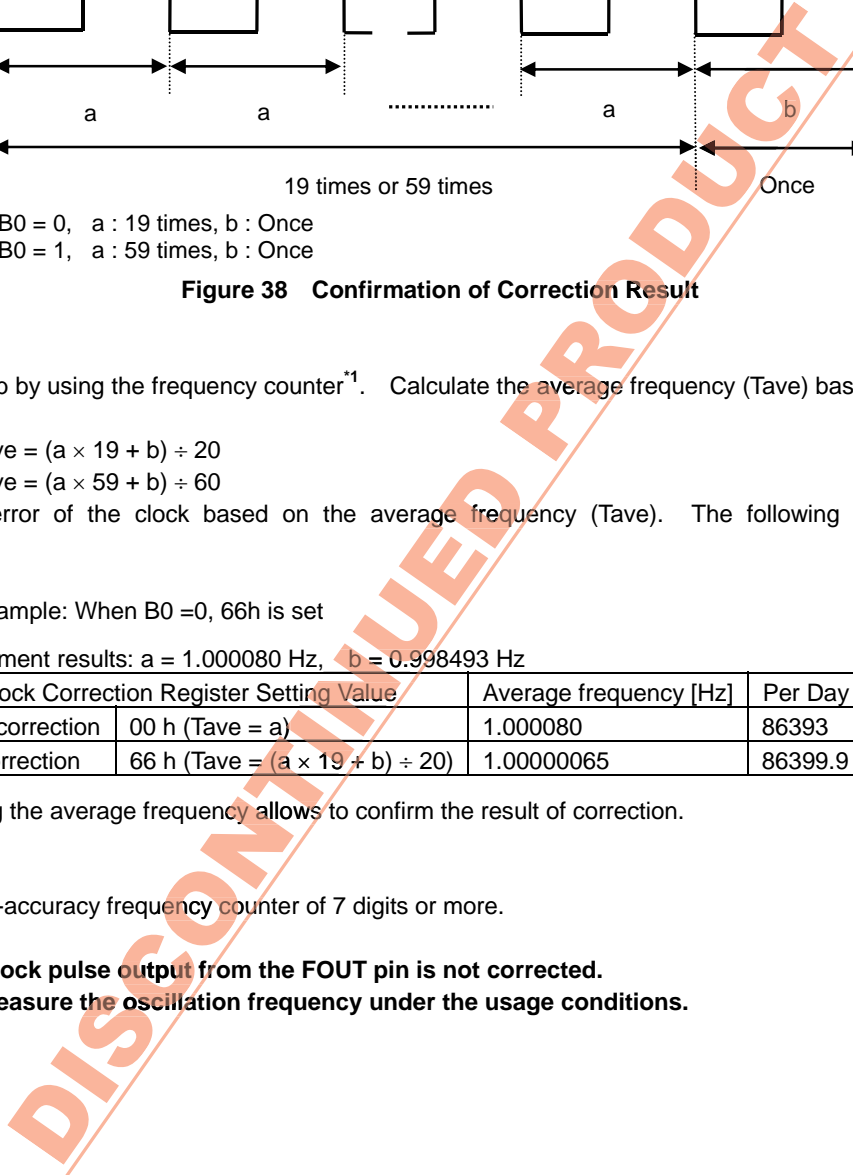

■ 32.768 kHz Output Pin

The S-35199A01 outputs a 32.768 kHz clock pulse from the  $\overline{INT}$ , F32K, and FOUT pins. However, do not output 32.768 kHz from these three pins simultaneously because stability of the crystal oscillator is affected.

When using the function to clock-correction or adjusting the oscillation frequency, measure the oscillation frequency under the usage conditions. For example, when using 32.768 kHz clock pulse which is output from the FOUT pin, measure this IC while the pulse is being output from the pin.

■ Timing of Clock Output from F32K Pin

The 32.768 kHz clock pulse of the oscillation frequency is output from the F32K pin. The F32K pin has an Nch open-drain output. When the CTRL pin is in "H", the clock pulse is output, and when the CTRL pin is in "L" or open, the F32K pin is in high impedance. To output 32.768 kHz from the F32K pin, set the CTRL pin to "H" when one sec or more has elapsed after power-on.

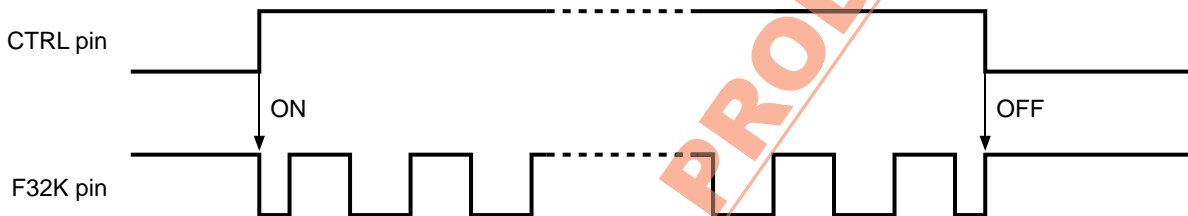

Figure 39 Timing of Clock Output from F32K Pin

■ Up-Count Operation

The up counter is a 24-bit read-only binary counter. This counter starts counting from "000000h" from power-on and returns to "000000h" at the next clock after it has reached "FFFFFFh". A clock pulse is a pulse that is output when the second-data in the real-time data is "00h". Therefore, some delay is made in the period that a clock pulse is being output due to Write timing and Write data. The registers are not initialized unless power-on again, so that users are able to grasp the elapsed time from power-on up to 30 years. Figure 40 shows the example of timing chart of up counter's operation.

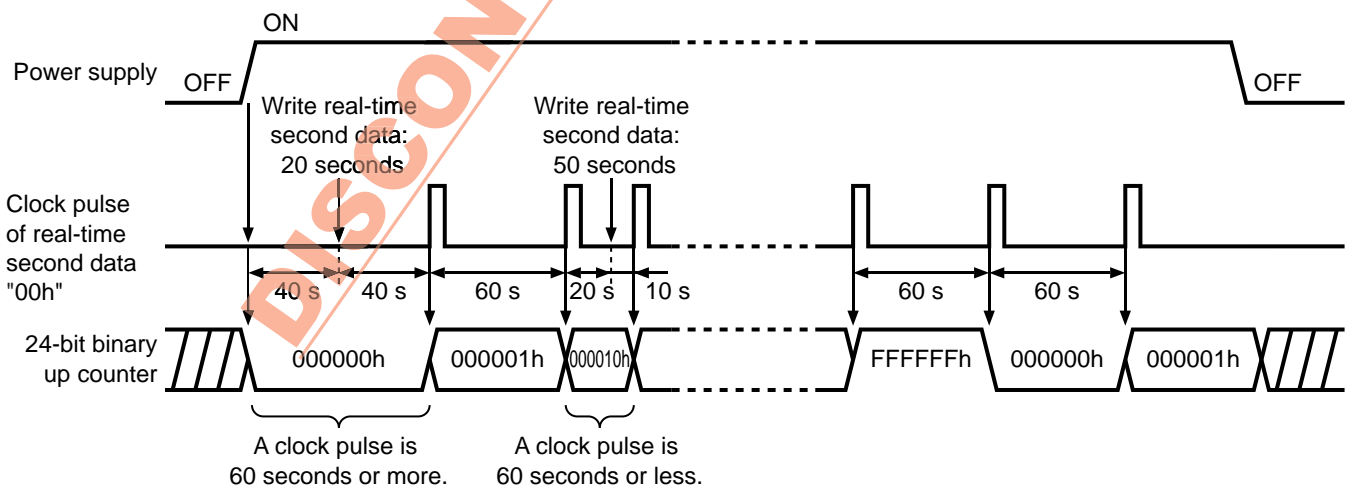

Figure 40 Timing Chart of 24-Bit Binary Up Counter

■ **Serial Interface**

The S-35199A01 receives various commands via a 3-wire serial interface to Read/Write data. Regarding transmission is as follows.

**1. Data Read**

When data is input from the SIO pin in synchronization with the falling of the  $\overline{\text{SCK}}$  clock after setting the CS pin to "H", the data is loaded internally in synchronization with the next rising of the  $\overline{\text{SCK}}$  clock. When  $\text{R}/\overline{\text{W}}$  bit = "1" is loaded at the eighth rising of the  $\overline{\text{SCK}}$  clock, the state of data reading is entered. Data corresponding to each command is then output in synchronization with the falling of the subsequent  $\overline{\text{SCK}}$  clock input. When the  $\overline{\text{SCK}}$  clock is less than 8, the IC is in the clock-wait status, and no processing is performed.

**2. Data Write**

When data is input from the SIO pin in synchronization with the falling of the  $\overline{\text{SCK}}$  clock after setting the CS pin to "H", the data is loaded internally in synchronization with the next rising of the  $\overline{\text{SCK}}$  clock. When  $\text{R}/\overline{\text{W}}$  bit = "0" is loaded at the eighth rising of the  $\overline{\text{SCK}}$  clock, the state of data writing is entered. In this state, the data, which is input in synchronization with the falling of the subsequent  $\overline{\text{SCK}}$  clock input, is written to registers according to each command. As well as in Read, when the  $\overline{\text{SCK}}$  clock is less than 8, the IC is in the clock-wait status, and no processing is performed.

**3. Data access**

**(1) Real-time data access 1**

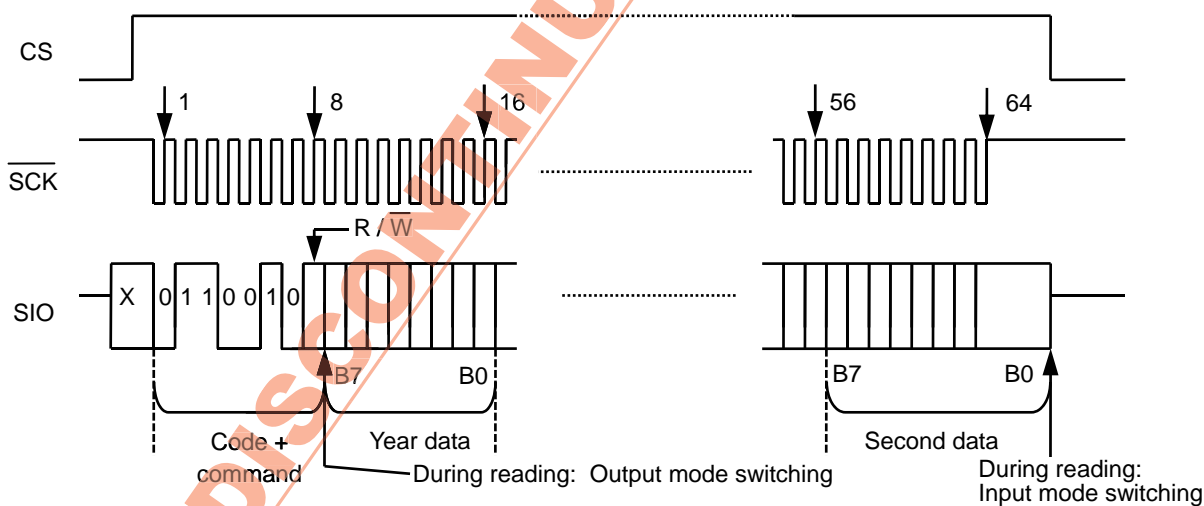

**Figure 41 Real-Time Data Access 1**

(2) Real-time data access 2

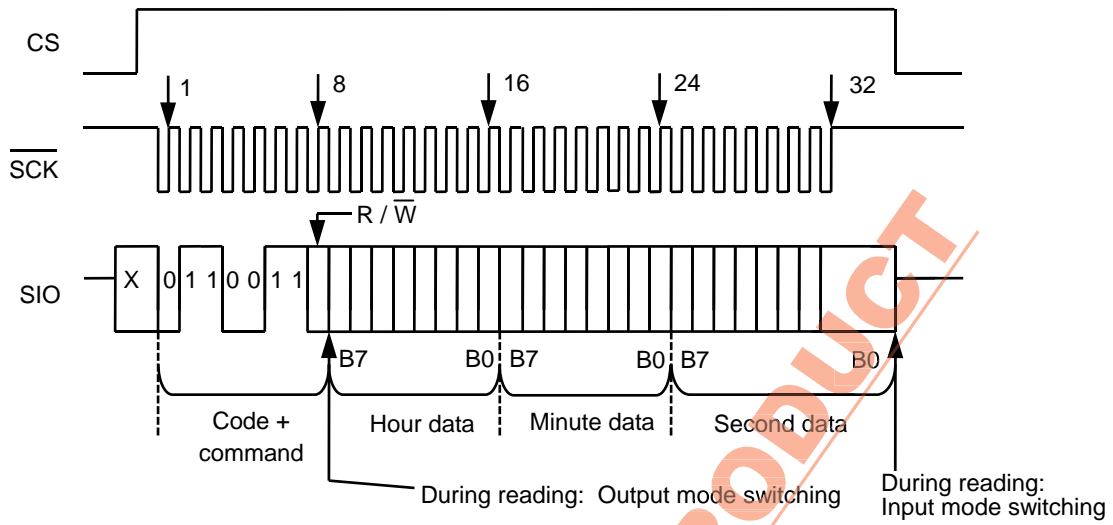
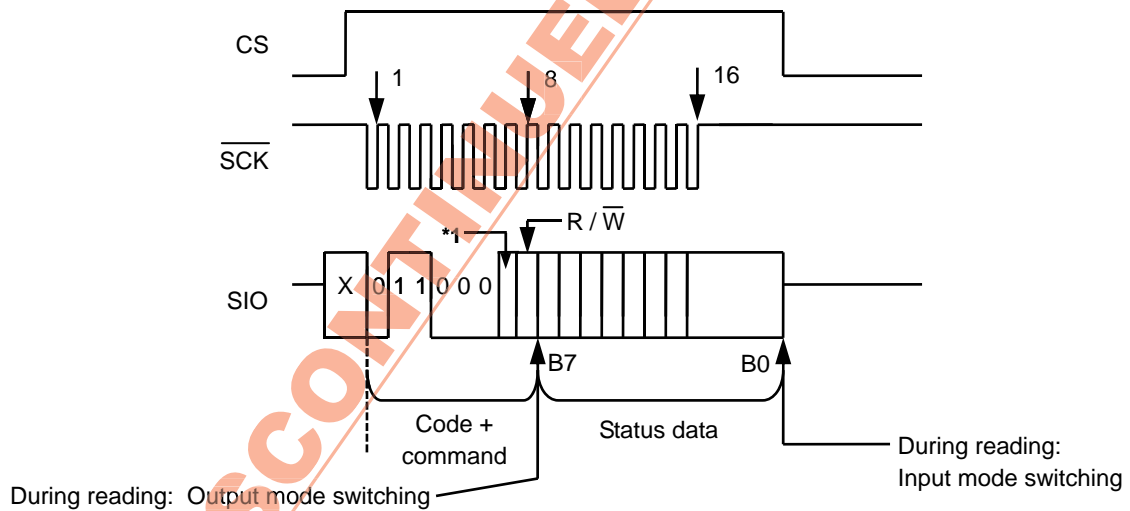

Figure 42 Real-Time Data Access 2

(3) Status register 1 access and status register 2 access



- \*1. 0 : Status register 1 selected
- 1 : Status register 2 selected

Figure 43 Status Register 1 Access and Status Register 2 Access

(4) INT register 1 access and INT register 2 access

In Read/Write the INT register 1, data varies depending on the setting of the status register 2. Be sure to Read/Write the INT register 1 after setting the status register 2. When setting the alarm by using the status register 2, these registers work as 3-byte alarm time data registers, in other statuses, they work as 1-byte registers. When outputting the user-set frequency, they are the data registers to set up the frequency.

**Caution** Users cannot use both functions of alarm 1 interrupt for  $\overline{\text{INT}}$  pin and the output of user-set frequency simultaneously.

Read/Write the INT register 2 after setting INT2AE in the status register 2. When INT2AE is in "1", the INT register 2 works as for setting the 3-byte alarm time data. The INT register 2 does not have the function to output the user-set frequency. Regarding details of each data, refer to "4. INT register 1 and INT register 2" in "■ Configuration of Register".

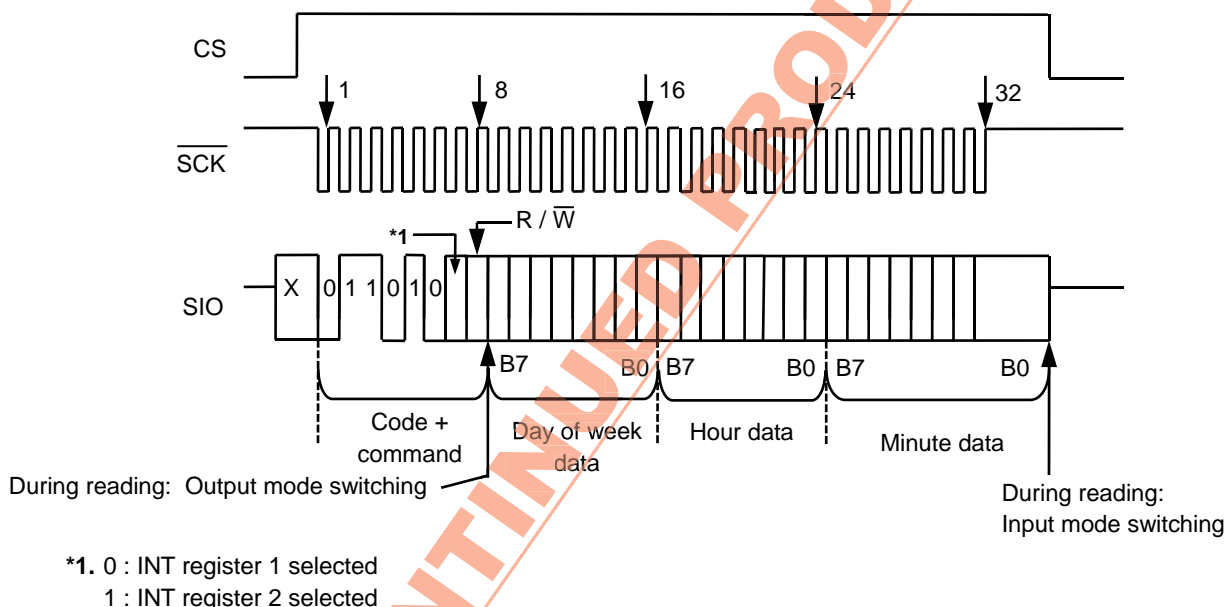

Figure 44 INT Register 1 Access and INT Register 2 Access

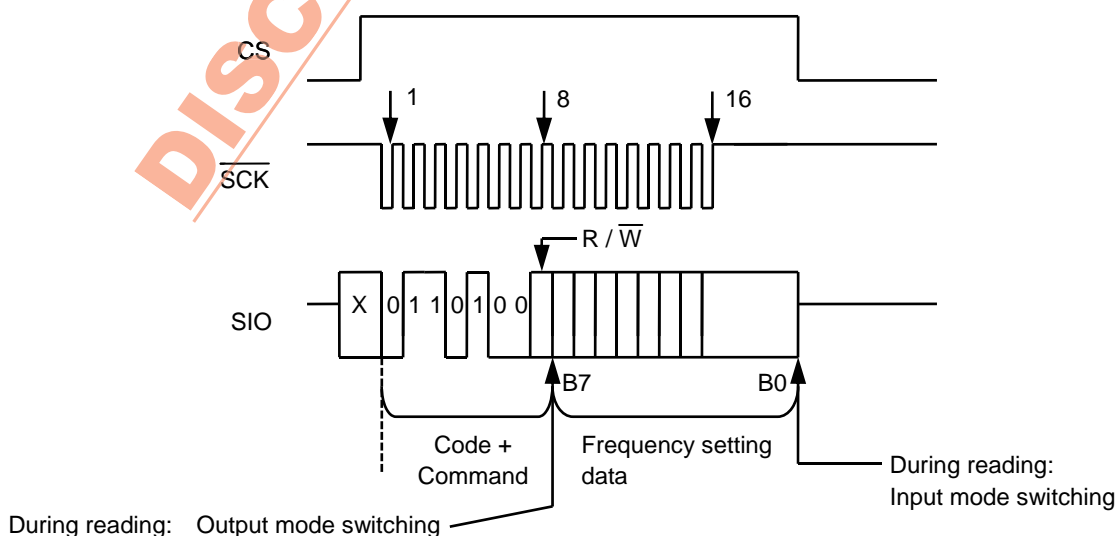

Figure 45 INT Register 1 (Data Register for output frequency) Access

(5) Clock correction register access

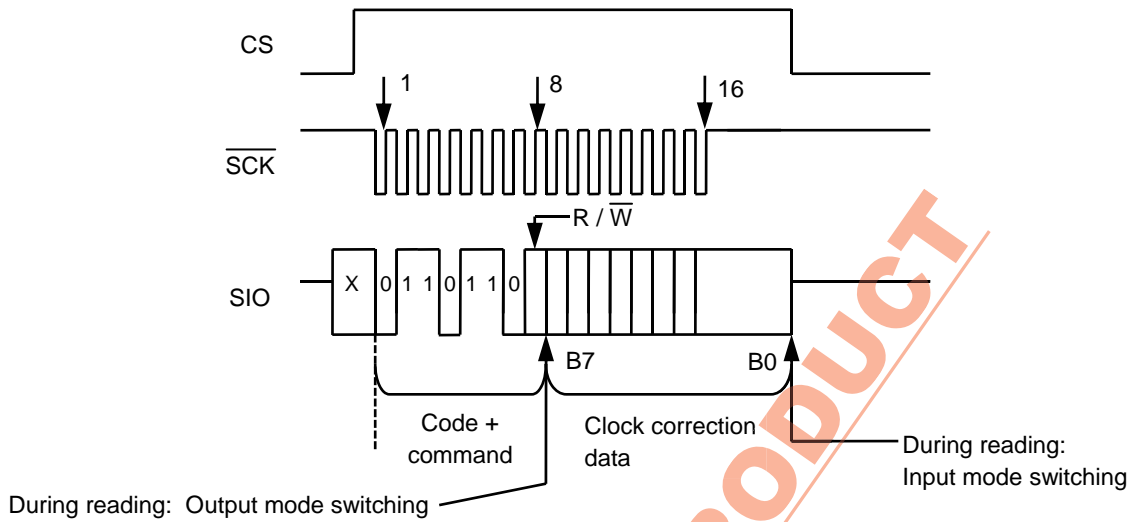

Figure 46 Clock Correction Register Access

(6) Free register access

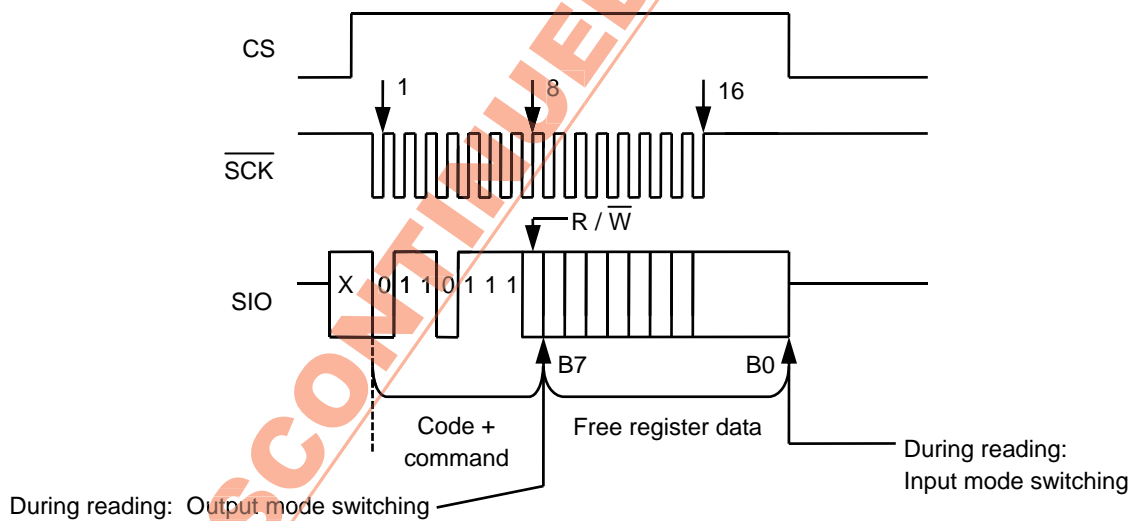
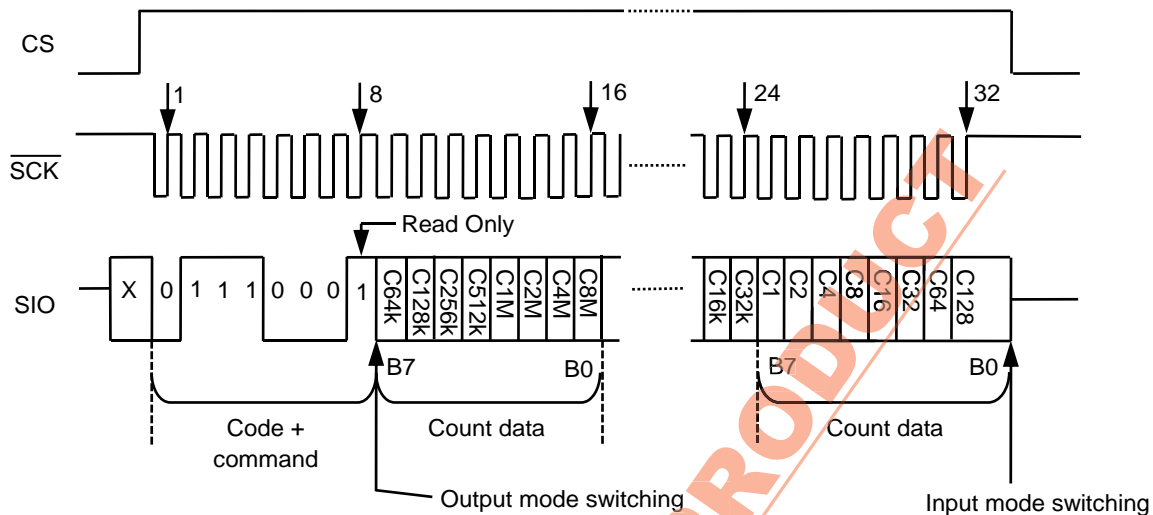

Figure 47 Free Register Access

**(7) Up counter access**

Access to the up counter is Read-only. Users cannot Write in this counter with Write operation.



**Figure 48 Up Counter Access**

**(8) FOUT setting register 1 access and FOUT setting register 2 access**

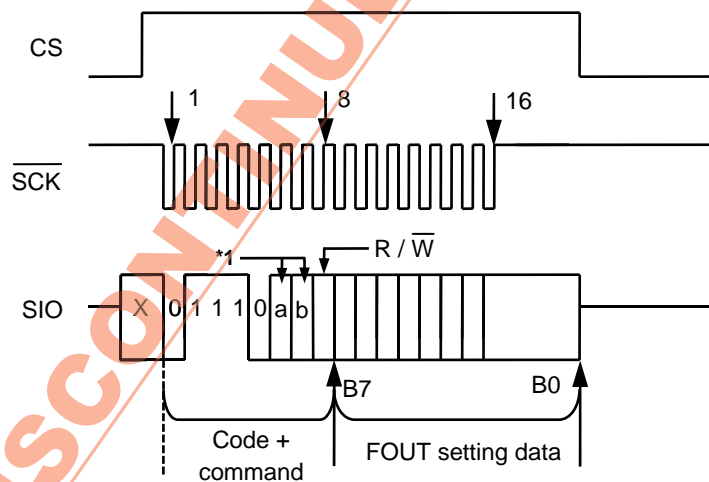

\*1 To select register, use the following settings.

a	b	Register to select
0	1	FOUT setting register 1
1	0	FOUT setting register 2

**Figure 49 FOUT Setting Register 1 Access and FOUT Setting Register 2 Access**



**(9) Alarm expansion register 1 access and alarm expansion register 2 access**

Write in the alarm expansion register 1 (alarm expansion register 2) after setting the status register 2.

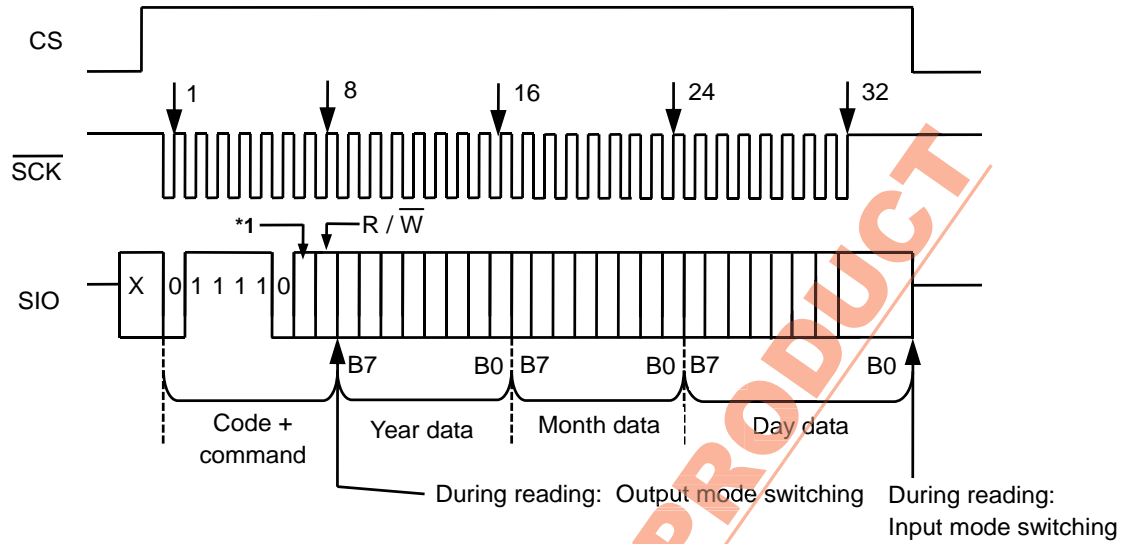

- \*1. 0 : Alarm expansion register 1 access
- 1 : Alarm expansion register 2 access

**Figure 50 Alarm Expansion Register 1 Access and Alarm Expansion Register 2 Access**

DISCONTINUED PRODUCT

■ Flowchart of Initialization at Power-on and Example of Real-time Data Set-up

Figure 51 shows the flowchart of initialization at power-on and an example of real-time data set-up. Regarding how to apply power, refer to “■ Power-on Detection Circuit and Register Status”. It is unnecessary for users to comply with this flowchart of real-time data strictly. And if using the default data at initializing, it is also unnecessary to set up again.

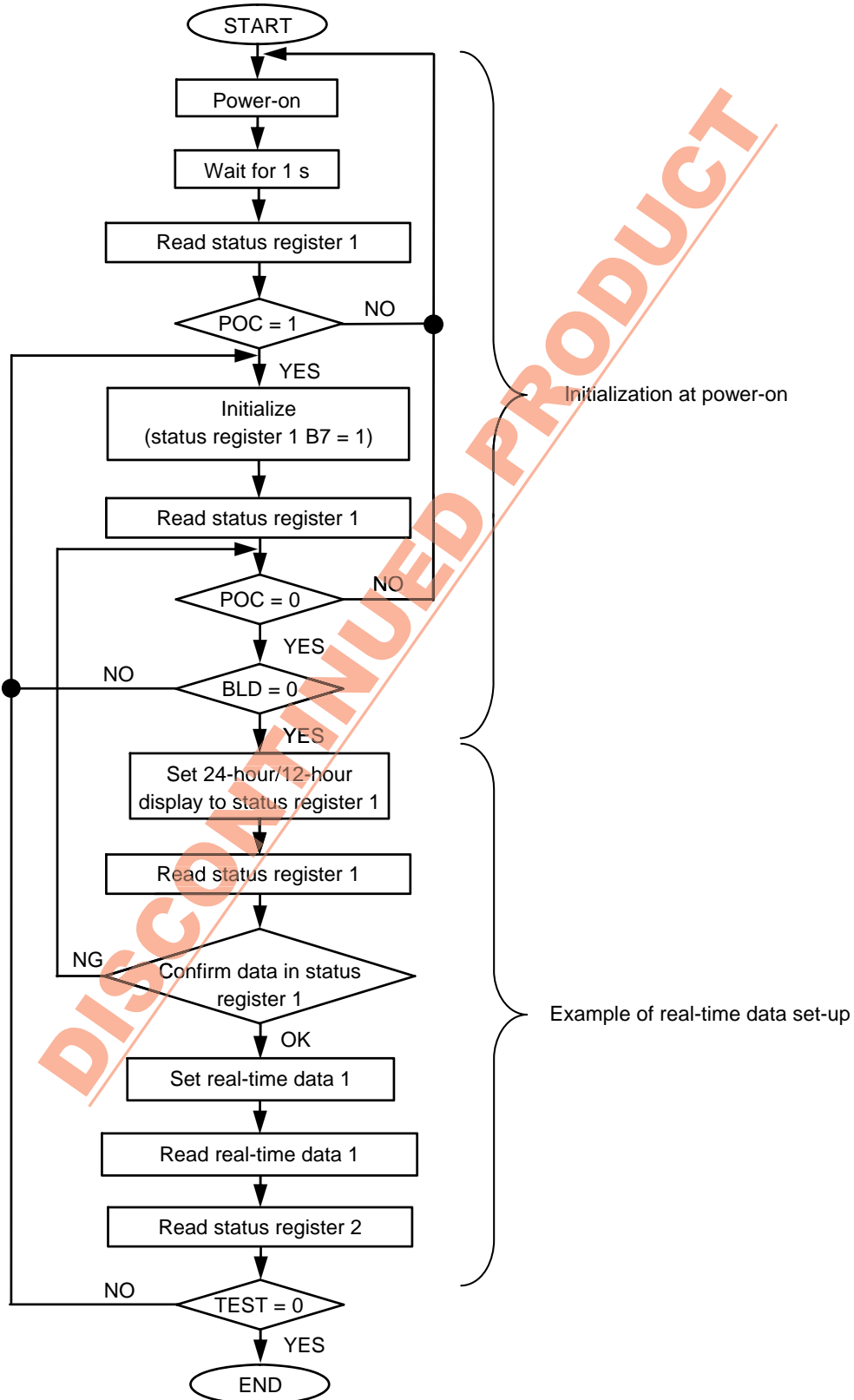
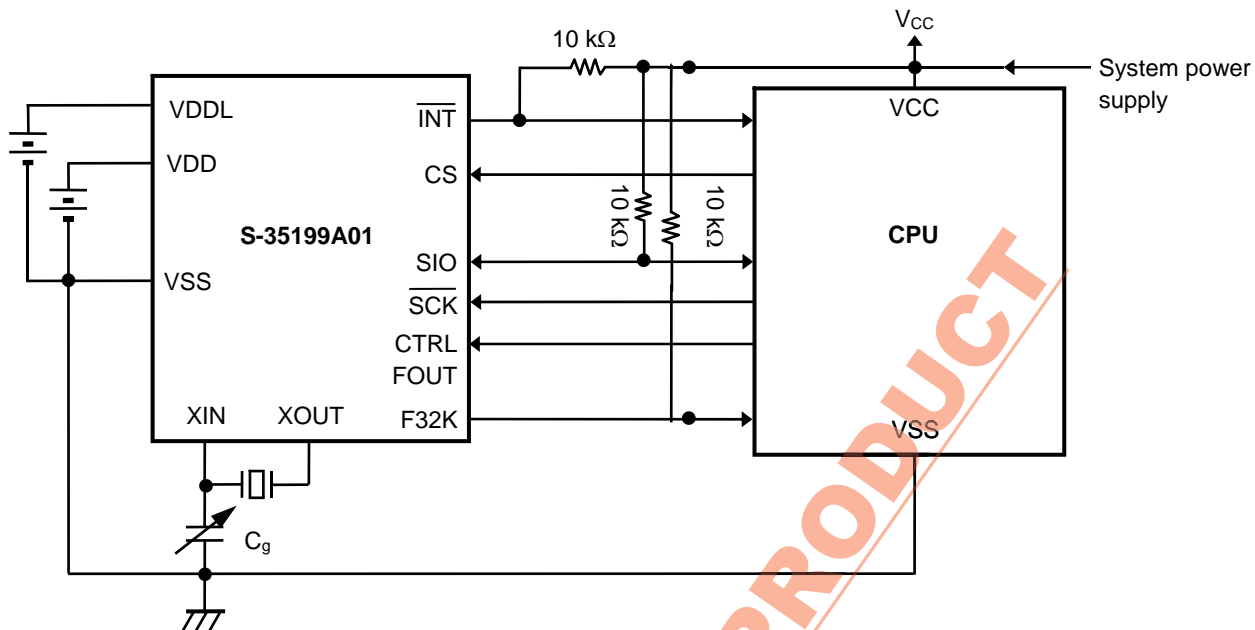

Figure 51 Example of Initialization Flowchart

■ Examples of Application Circuits



- Caution**
1. Because the I/O pin has no protective diode on the V<sub>DD</sub> side, the relation of V<sub>CC</sub> ≥ V<sub>DD</sub> is possible. But pay careful attention to the specifications.
  2. Start communication under stable condition after power-on the power supply in the system.

Figure 52 Application Circuit 1

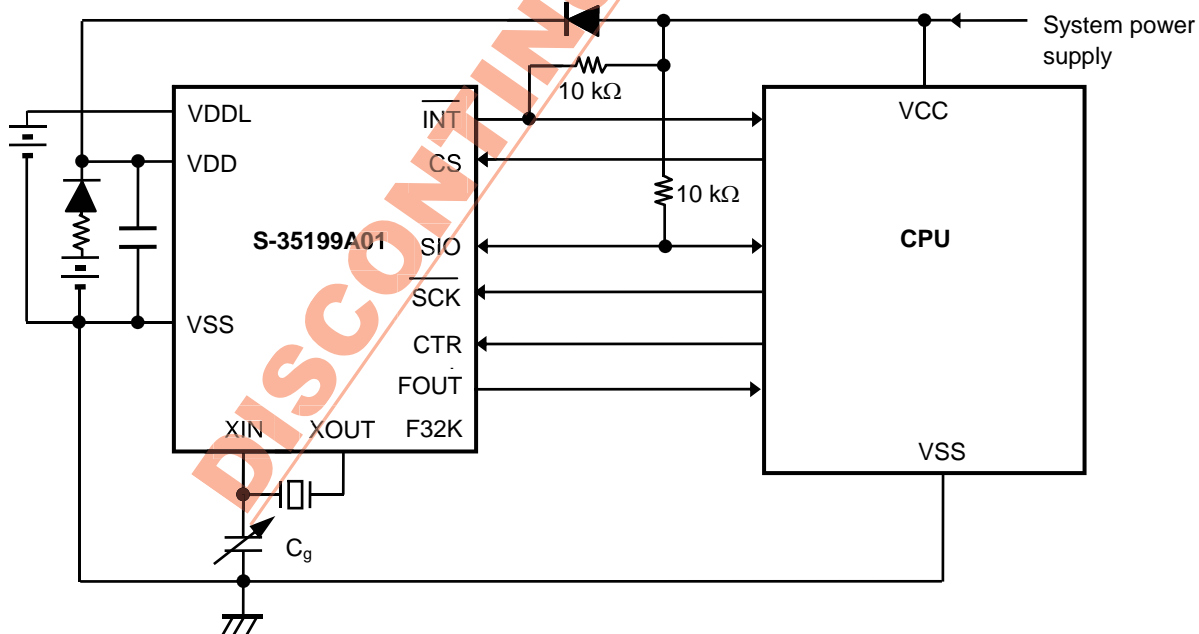

**Caution** Start communication under stable condition after power-on the power supply in the system.

Figure 53 Application Circuit 2

**Caution** The above connection diagrams do not guarantee operation. Set the constants after performing sufficient evaluation using the actual application.

## ■ Adjustment of Oscillation Frequency

### 1. Configuration of oscillation

Since crystal oscillation is sensitive to external noise (the clock accuracy is affected), the following measures are essential for optimizing the oscillation configuration.

- (1) Place the S-35199A01, crystal oscillator, and external capacitor ( $C_g$ ) as close to each other as possible.
- (2) Increase the insulation resistance between pins and the substrate wiring patterns of XIN and XOUT.
- (3) Do not place any signal or power lines close to the oscillator.
- (4) Locating the GND layer immediately below the oscillator is recommended.
- (5) Locate the bypass capacitor adjacent to the power supply pin of the S-35199A01.

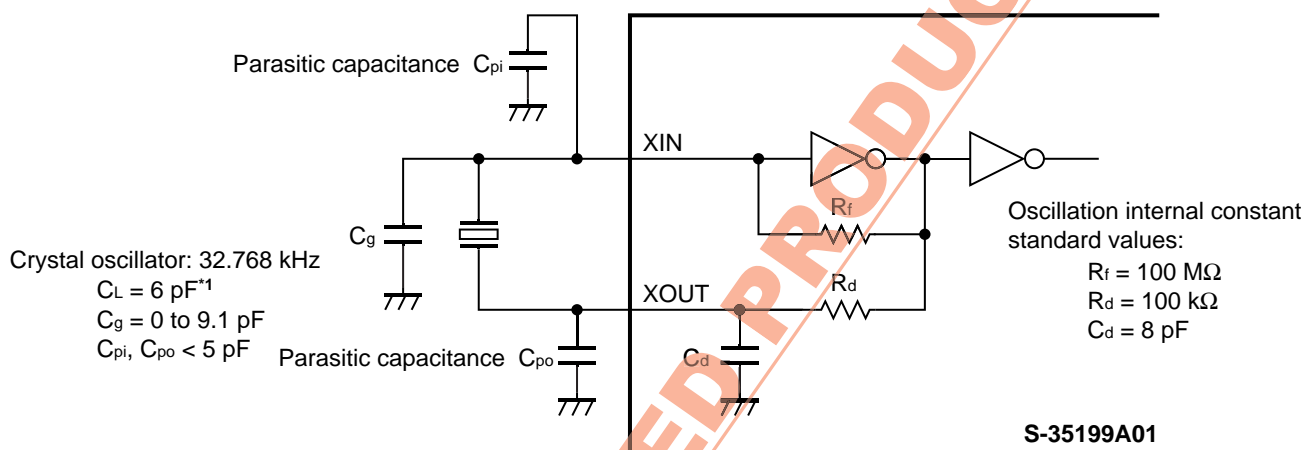

\*1. When using the crystal oscillator with a  $C_L$  value of 7 pF, externally connect  $C_d$  if necessary.

Figure 54 Connection Diagram 1

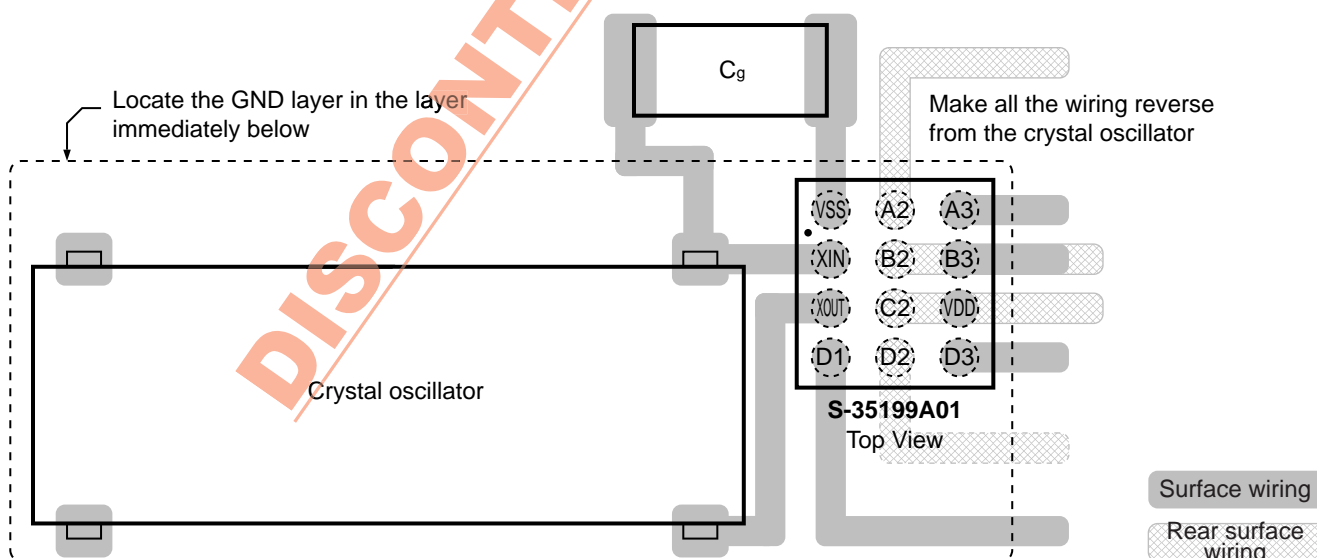

Figure 55 Connection Diagram 2

- Caution**
1. When using the crystal oscillator with a  $C_L$  exceeding the rated value (7 pF) (e.g :  $C_L = 12.5$  pF), oscillation operation may become unstable. Use a crystal oscillator with a  $C_L$  value of 6 pF or 7 pF.
  2. Oscillation characteristics is subject to the variation of each component such as substrate parasitic capacitance, parasitic resistance, crystal oscillator, and  $C_g$ . When configuring oscillator, pay sufficient attention for them.

## 2. Measurement of oscillation frequency

When the S-35199A01 is turned on, the internal power-on detection circuit operates and a signal of 1 Hz is output from the  $\overline{\text{INT}}$  pin to select the crystal oscillator and optimize the  $C_g$  value. Turn the power on and measure the signal with a frequency counter following the circuit configuration shown in **Figure 56**.

If 1 Hz signal is not output, the power-on detection circuit does not operate normally. Turn off the power and then turn it on again. For how to apply power, refer to “**Power-on Detection Circuit and Register Status**”.

**Remark** If the error range is  $\pm 1$  ppm in relation to 1 Hz, the time is shifted by approximately 2.6 seconds per month (calculated using the following expression).

$$10^{-6} (1 \text{ ppm}) \times 60 \text{ seconds} \times 60 \text{ minutes} \times 24 \text{ hours} \times 30 \text{ days} = 2.592 \text{ seconds}$$

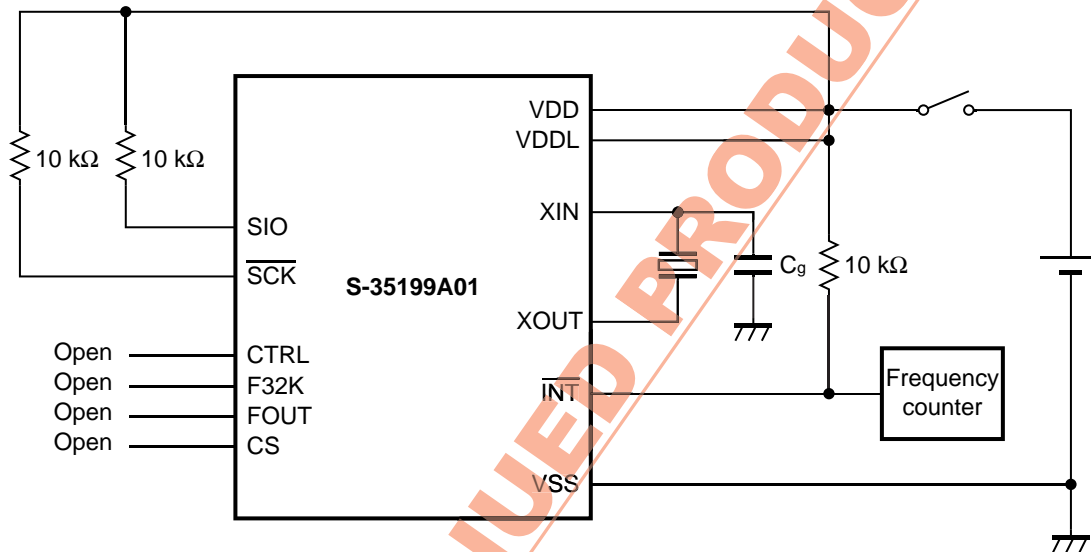

Figure 56 Configuration of Oscillation Frequency Measurement Circuit

- Caution**
1. Use a high-accuracy frequency counter of 7 digits or more.
  2. Measure the oscillation frequency under the usage condition.
  3. Since the 1 Hz signal continues to be output, initialization must be executed during normal operation.

### 3. Adjustment of oscillation frequency

#### (1) Adjustment by setting $C_g$

Matching of the crystal oscillator with the nominal frequency must be performed with the stray capacitance on the board included. Select a crystal oscillator and optimize the  $C_g$  value in accordance with the flowchart below.

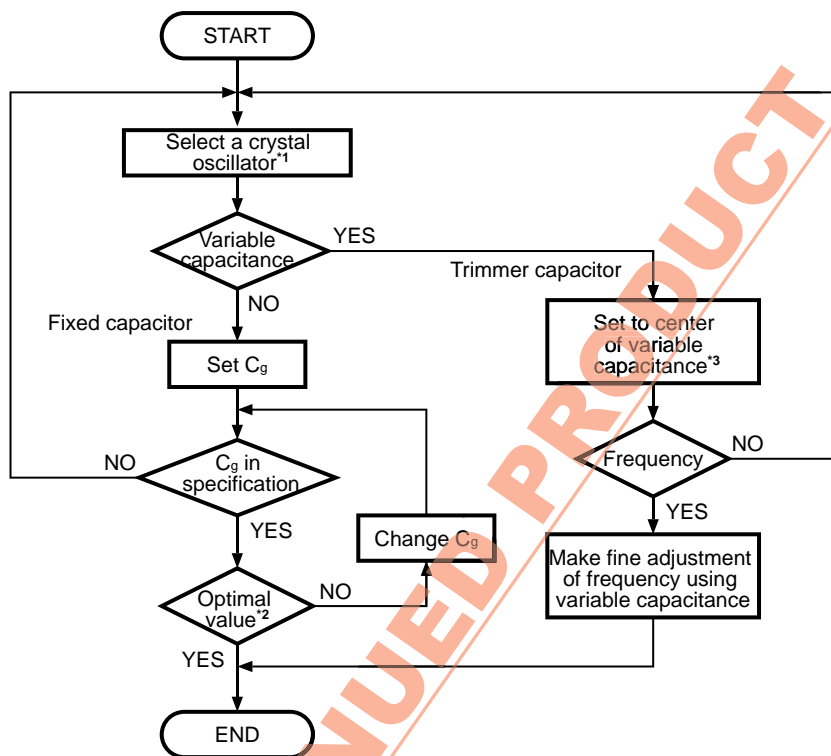

\*1. Request a crystal manufacturer for matching evaluation between the IC and a crystal. The recommended crystal characteristic values are,  $C_L$  value (load capacitance) = 6 pF,  $R_1$  value (equivalent serial resistance) = 50 k $\Omega$  max.

\*2. The  $C_g$  value must be selected on the actual PCB since it is affected by stray capacitance. Select the external  $C_g$  value in a range of 0 pF to 9.1 pF.

\*3. Adjust the rotation angle of the variable capacitance so that the capacitance value is slightly smaller than the center, and confirm the oscillation frequency and the center value of the variable capacitance. This is done in order to make the capacitance of the center value smaller than one half of the actual capacitance value because a smaller capacitance value increases the frequency variation.

Figure 57 Crystal Oscillator Setting Flow

- Caution**
1. The oscillation frequency varies depending on the ambient temperature and power supply voltage. Refer to the characteristics examples.
  2. The 32.768 kHz crystal oscillator operates more slowly at an operating temperature than higher or lower 20 to 25°C. Therefore, it is recommended to set the oscillator to operate slightly faster at normal temperature.

## ■ Product Name Structure

### 1. Product name

S-35199A01 - HRT1

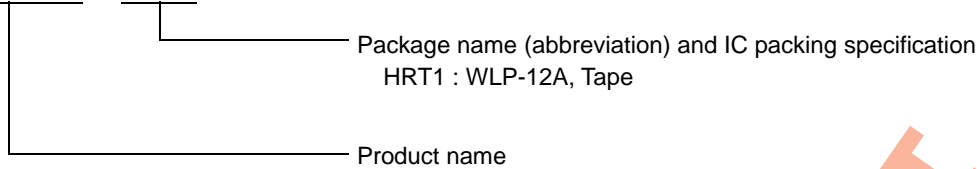

### 2. Package

Package Name	Drawing Code		
	Package	Tape	Reel
WLP-12A	HA012-A-P-SD	HA012-A-C-SD	HA012-A-R-SD

## ■ Precautions

- Although the IC contains a static electricity protection circuit, static electricity or voltage that exceeds the limit of the protection circuit should not be applied.
- Seiko Instruments Inc. assumes no responsibility for the way in which this IC is used in products created using this IC or for the specifications of that product, nor does Seiko Instruments Inc. assume any responsibility for any infringement of patents or copyrights by products that include this IC either in Japan or in other countries.

## ■ Cautions on Using WLP Package

- The silicon surface of the device is exposed on the marking side of the package. This portion is less strong against the mechanical stress compared with normal plastic packages, handle packages with extreme care to avoid any cracking and defects. The PCB potential of the device is exposed on the silicon surface, so be careful not to touch the external potential.
- Translucent resin is coated over the device side of this package.  
Note that using the package with the device exposed to a strong light source may affect the device characteristics.

■ Characteristics (Typical Data)

(1) Current consumption 1 (current consumption out of communication) vs.  $V_{DD}$  characteristics

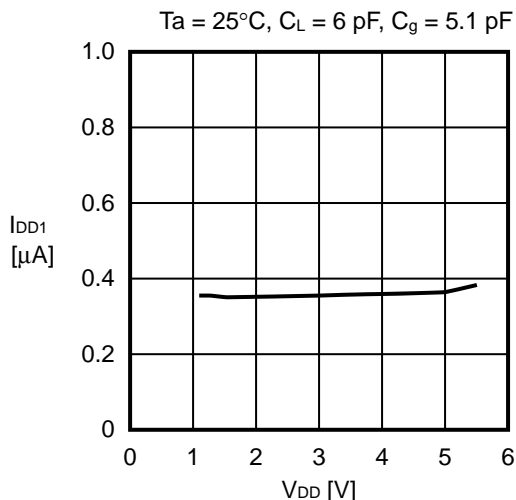

(2) Current consumption 2 (current consumption when 32.768 kHz is output) vs.  $V_{DD}$  characteristics

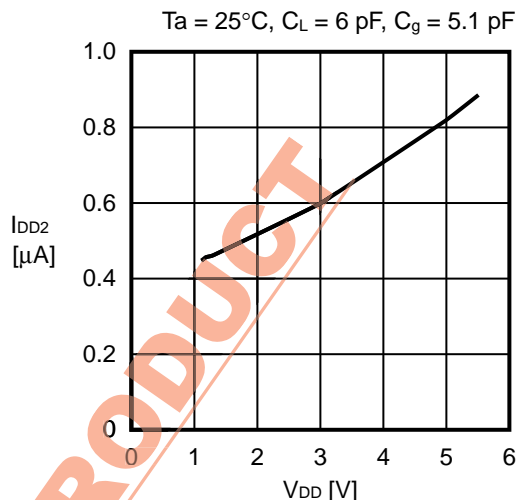

(3) Current consumption 3 (current consumption during communication) vs. Input clock characteristics

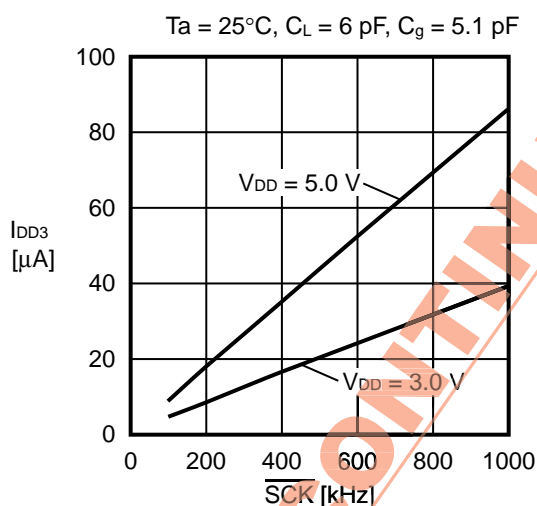

(4) Current consumption 1 (current consumption out of communication) vs. Temperature characteristics

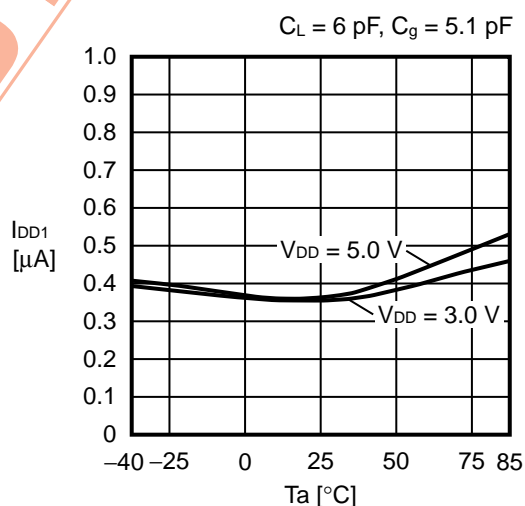

(5) Current consumption 1 (current consumption out of communication) vs.  $C_g$  characteristics

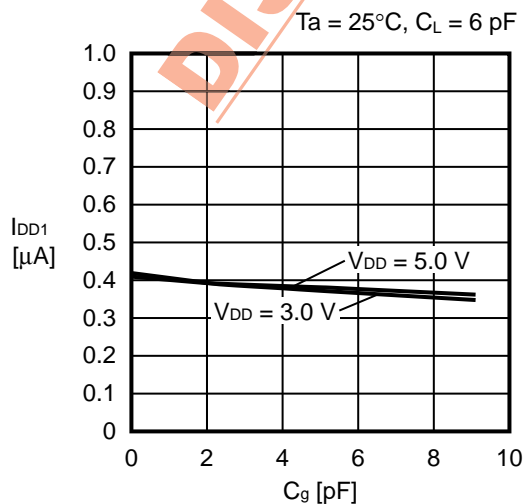

(6) Oscillation frequency vs.  $C_g$  characteristics

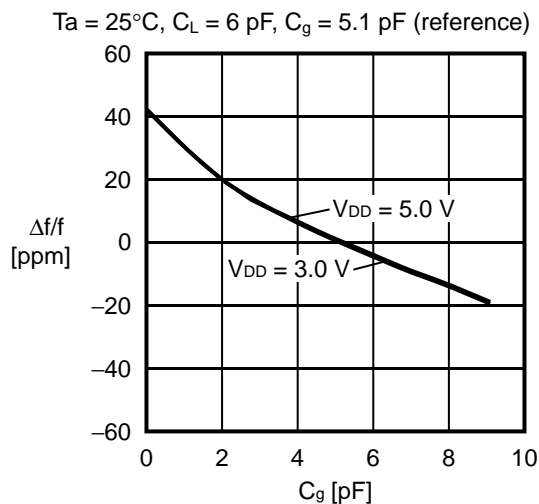



(7) Oscillation frequency vs.  $V_{DD}$  characteristics

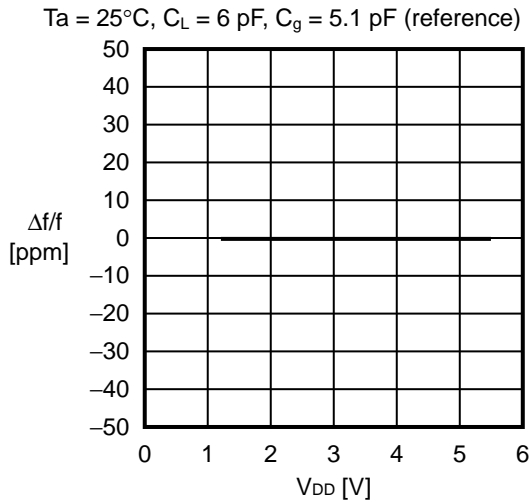

(8) Oscillation frequency vs. Temperature characteristics

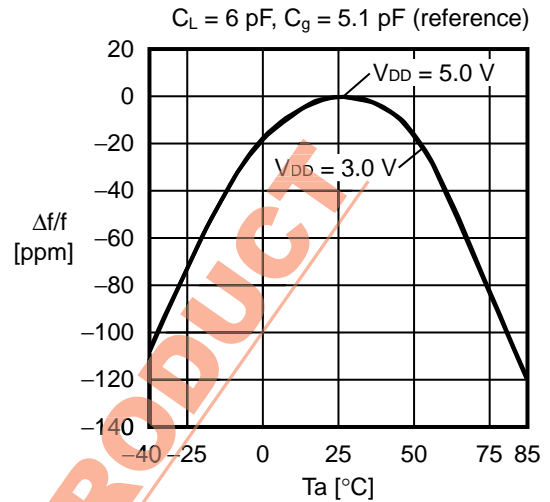

(9) Oscillation start time vs. Temperature characteristics (XOUT PIN MONITORED)

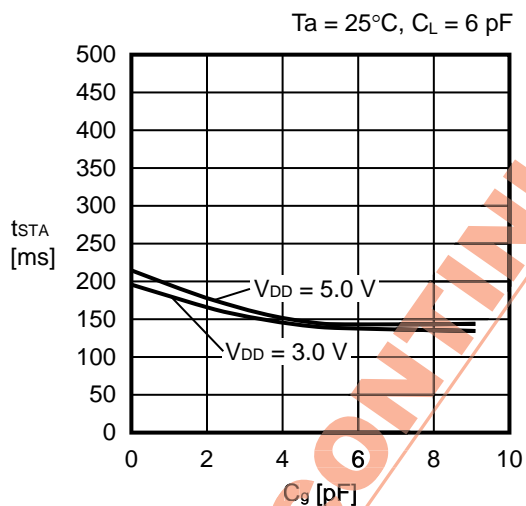

(10) Output current characteristics 1 ( $V_{OUT}$  vs.  $I_{OL1}$ )

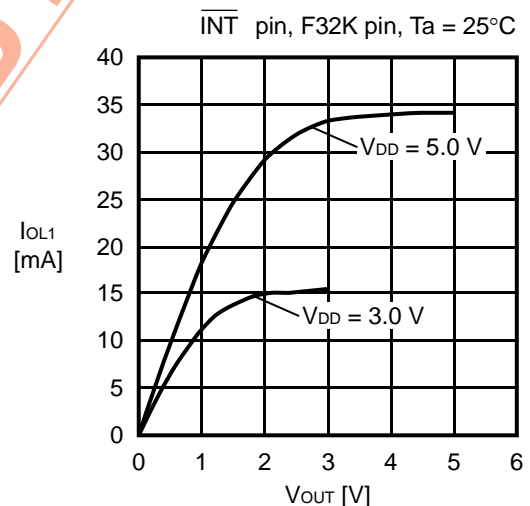

(11) Output current characteristics 2 ( $V_{OUT}$  vs.  $I_{OL2}$ )

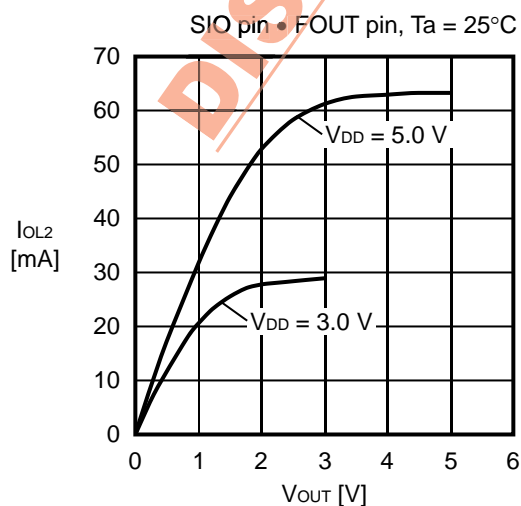

(12) Output current characteristics 3 ( $V_{DD}$  vs.  $I_{OH}$ )

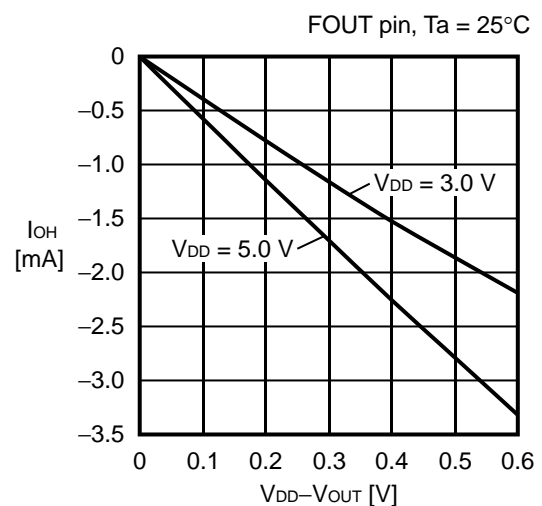

**(13) Input current characteristics 3 ( $V_{IN}$  vs.  $I_{IH}$ )**

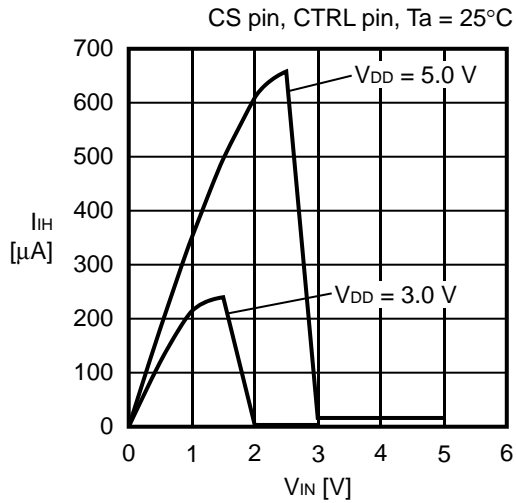

**(14) Low power supply voltage detection voltage and release voltage, time keeping power supply voltage (Min) vs. Temperature characteristics**

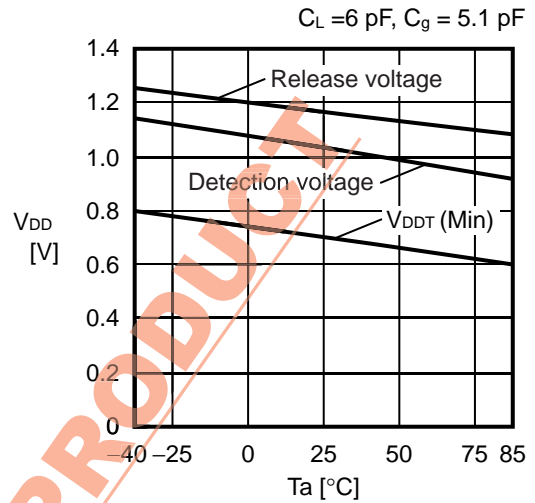

**(15) Characteristics of power-on detection circuit**

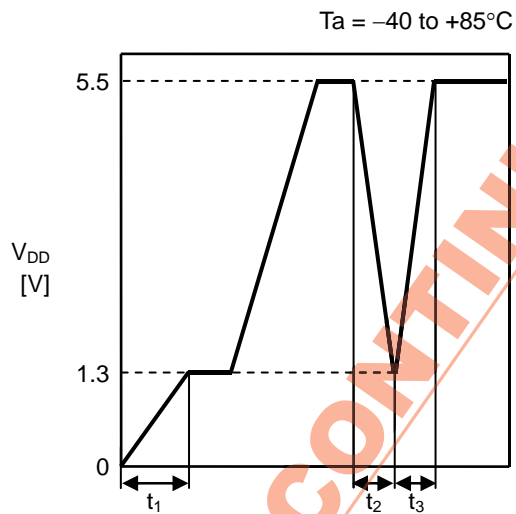

- $t_1$  : A condition that power-on detection works at turning on  
 $t_1 \leq 10\text{ ms}$
- $t_2$  : A condition that the IC works regularly and data is retained during power voltage drop  
 $t_2 \geq 1\text{ ms}$
- $t_3$  : A condition that the IC works regularly and data is retained during power voltage rise  
 $t_3 \geq 1\text{ ms}$

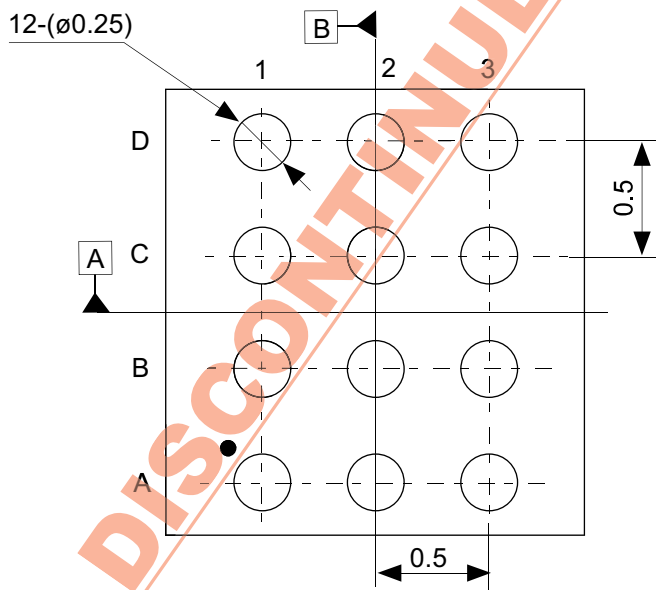
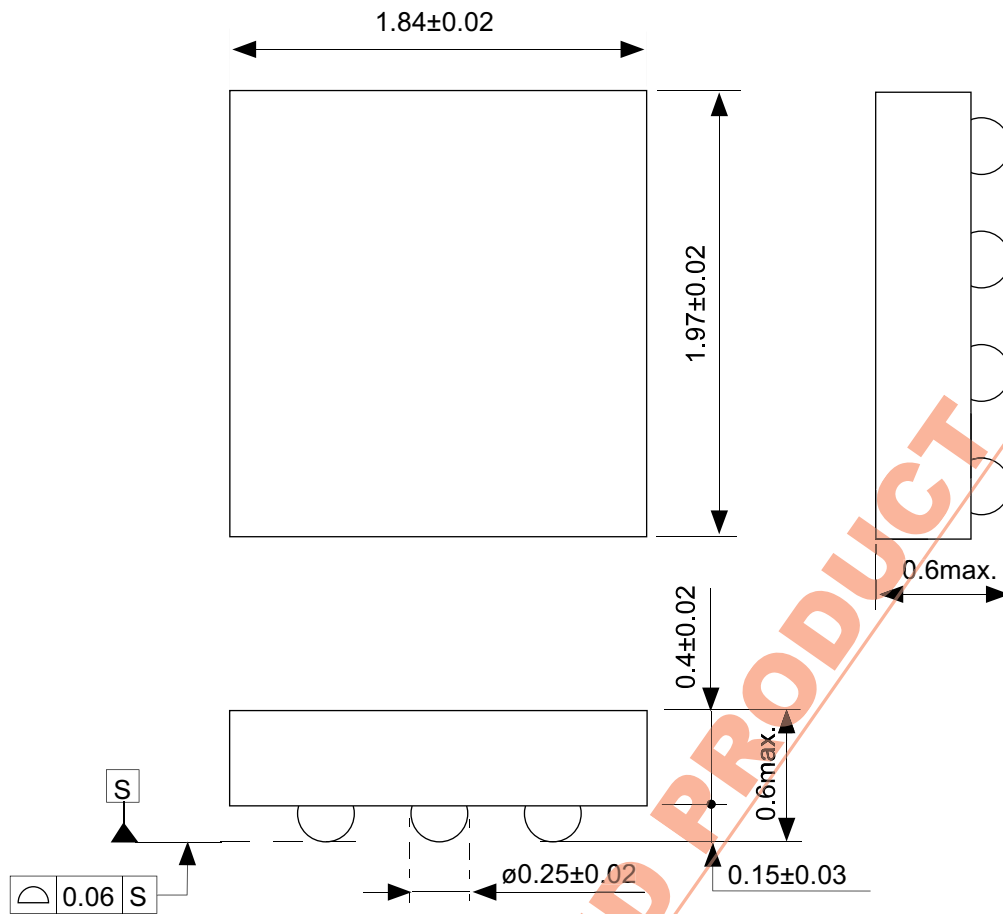

Pin No.	Pin name
A1	VSS
A2	SIO
A3	CS
B1	XIN
B2	CTRL
B3	SCK
C1	XOUT
C2	INT
C3	VDD
D1	VDDL
D2	FOUT
D3	F32K

No. HA012-A-P-SD-3.0

TITLE	WLP-12A-A-PKG Dimensions (S-35199A)
No.	HA012-A-P-SD-3.0
SCALE	
UNIT	
Seiko Instruments Inc.	

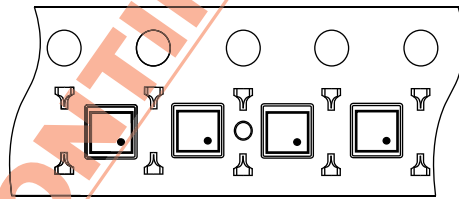
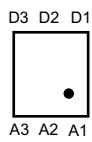
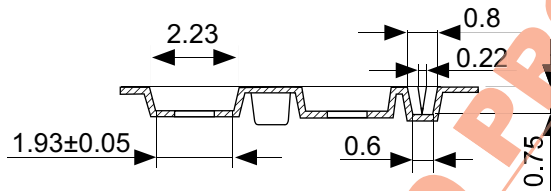
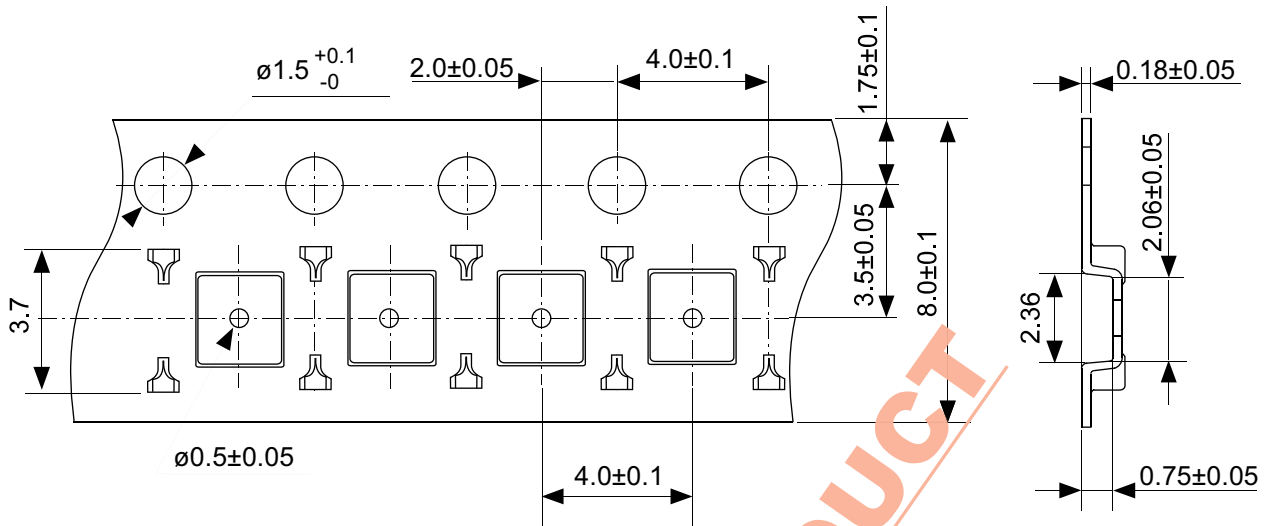

Feed direction

No. HA012-A-C-SD-2.1

TITLE	WLP-12A-A-Carrier Tape (S-35199A)
No.	HA012-A-C-SD-2.1
SCALE	
UNIT	mm
Seiko Instruments Inc.	

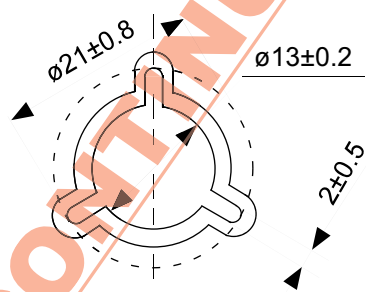
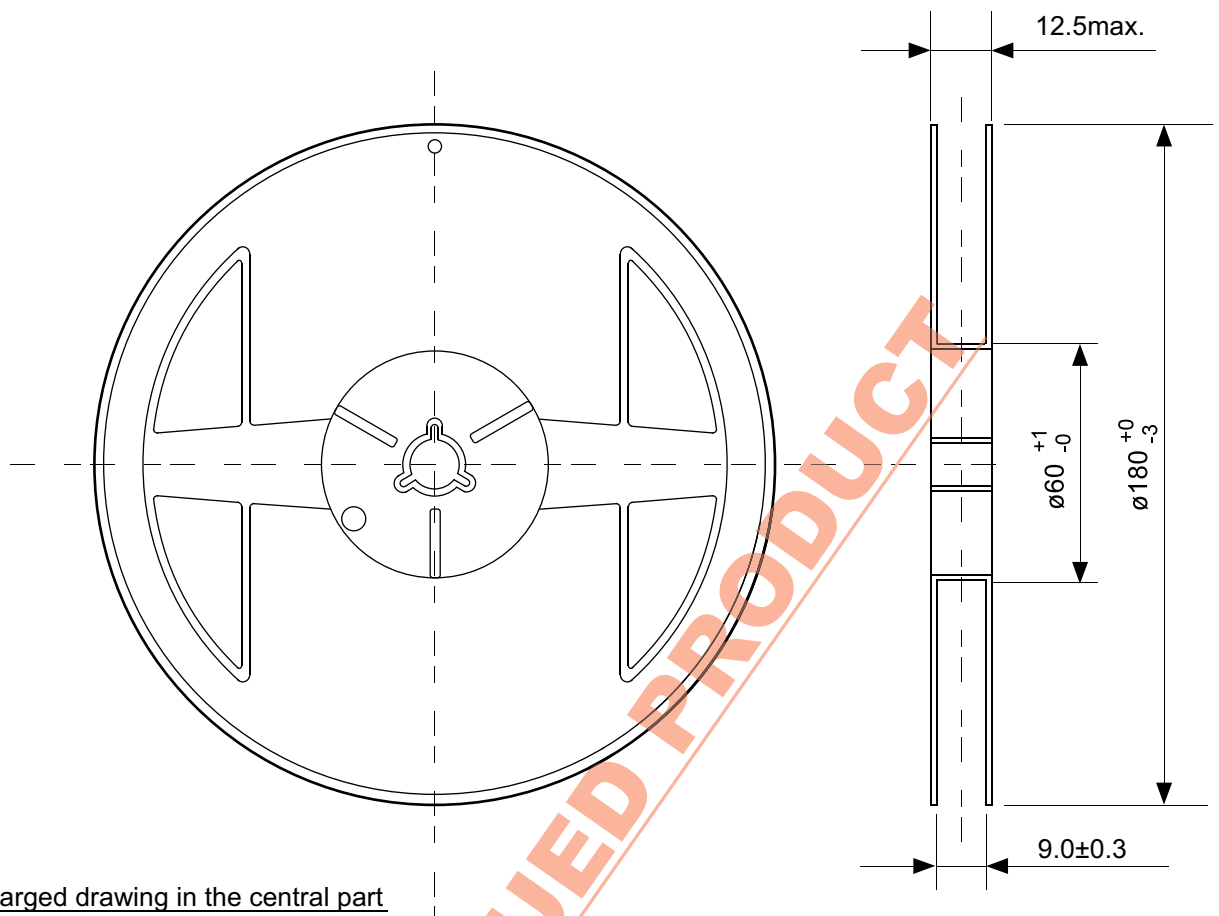

DISCONTINUED PRODUCT

No. HA012-A-R-SD-1.1

TITLE	WLP-12A-A-Reel (S-35199A)		
No.	HA012-A-R-SD-1.1		
SCALE		QTY.	3,000
UNIT	mm		
Seiko Instruments Inc.			



Seiko Instruments Inc.  
[www.sii-ic.com](http://www.sii-ic.com)

- The information described herein is subject to change without notice.
- Seiko Instruments Inc. is not responsible for any problems caused by circuits or diagrams described herein whose related industrial properties, patents, or other rights belong to third parties. The application circuit examples explain typical applications of the products, and do not guarantee the success of any specific mass-production design.
- When the products described herein are regulated products subject to the Wassenaar Arrangement or other agreements, they may not be exported without authorization from the appropriate governmental authority.
- Use of the information described herein for other purposes and/or reproduction or copying without the express permission of Seiko Instruments Inc. is strictly prohibited.
- The products described herein cannot be used as part of any device or equipment affecting the human body, such as exercise equipment, medical equipment, security systems, gas equipment, or any apparatus installed in airplanes and other vehicles, without prior written permission of Seiko Instruments Inc.
- Although Seiko Instruments Inc. exerts the greatest possible effort to ensure high quality and reliability, the failure or malfunction of semiconductor products may occur. The user of these products should therefore give thorough consideration to safety design, including redundancy, fire-prevention measures, and malfunction prevention, to prevent any accidents, fires, or community damage that may ensue.

# Mouser Electronics

Authorized Distributor

Click to View Pricing, Inventory, Delivery & Lifecycle Information:

[ABLIC:](#)

[S-35199A01-HRT1](#)

Компания «Life Electronics» занимается поставками электронных компонентов импортного и отечественного производства от производителей и со складов крупных дистрибьюторов Европы, Америки и Азии.

С конца 2013 года компания активно расширяет линейку поставок компонентов по направлению коаксиальный кабель, кварцевые генераторы и конденсаторы (керамические, пленочные, электролитические), за счёт заключения дистрибьюторских договоров

Мы предлагаем:

- Конкурентоспособные цены и скидки постоянным клиентам.
- Специальные условия для постоянных клиентов.
- Подбор аналогов.
- Поставку компонентов в любых объемах, удовлетворяющих вашим потребностям.
- Приемлемые сроки поставки, возможна ускоренная поставка.
- Доставку товара в любую точку России и стран СНГ.
- Комплексную поставку.
- Работу по проектам и поставку образцов.
- Формирование склада под заказчика.
- Сертификаты соответствия на поставляемую продукцию (по желанию клиента).
- Тестирование поставляемой продукции.
- Поставку компонентов, требующих военную и космическую приемку.
- Входной контроль качества.
- Наличие сертификата ISO.

В составе нашей компании организован Конструкторский отдел, призванный помогать разработчикам, и инженерам.

Конструкторский отдел помогает осуществить:

- Регистрацию проекта у производителя компонентов.
- Техническую поддержку проекта.
- Защиту от снятия компонента с производства.
- Оценку стоимости проекта по компонентам.
- Изготовление тестовой платы монтаж и пусконаладочные работы.



Тел: +7 (812) 336 43 04 (многоканальный)  
Email: [org@lifeelectronics.ru](mailto:org@lifeelectronics.ru)