

Dual-Wire Dual Operator Monitor Installation, Operation and Maintenance



Made in the
United States of America



Figure 1. Desco Dual-Wire Dual Operator Monitor

The Dual-Wire Dual Operator Monitor and its accessories are available in the following item numbers:

Item	Description
19665	Dual-Wire Dual Operator Monitor
50524	Limit Comparator
50525	Replacement Operator Remote Kit, Black
50526	Replacement Operator Remote Kit, White
19262	Replacement Power Adapter, 12 VDC

Description

The Desco [19665](#) Dual-Wire Dual Operator Monitor monitors two operators and two ESD worksurfaces eliminating the need for periodic testing and record keeping of wrist straps. The Dual-Wire Dual Operator Monitor uses low-voltage steady state DC continuous-loop technology to continuously monitor (versus pulsed or intermittent) dual-wire wrist strap functionality. Independent audio and visual alarm conditions make it easy to identify the status of the worksurfaces and operators. Two operator remotes with 10 foot cables are included for use at adjacent workstations. Each monitor is calibrated with accepted procedures and standards traceable to the National Institute of Standards and Technology (NIST) and includes a NIST certificate.

ANSI/ESD S20.20 section 7.3 states “Compliance verification records shall be established and maintained to provide evidence of conformity to the technical requirements.” Per ANSI/ESD S1.1 Annex A.3 Daily (wrist strap system) testing may be omitted if constant monitoring used.” Per ESD Handbook ESD TR 20.20 section 5.3.2.4.4 “Typical Test programs recommend that wrist straps that are used daily should be tested daily. However, if the products that are being produced are of such value that knowledge of a continuous, reliable ground is needed, and then continuous monitoring should be considered or even required.”

Packaging

- 1 Dual-Wire Dual Operator Monitor
- 1 Power Adapter, 12VDC, with interchangeable plugs (North America, UK/Asia, Europe)
- 2 Operator Remotes with Attached Cables (1 Black, 1 White)
- 2 Mat Monitor Cords (1 Black, 1 White)
- 2 Mat Ground Cords
- 1 Monitor Ground Cord
- 1 Universal Snap Kit
- 1 Certificate of Calibration

Features and Components

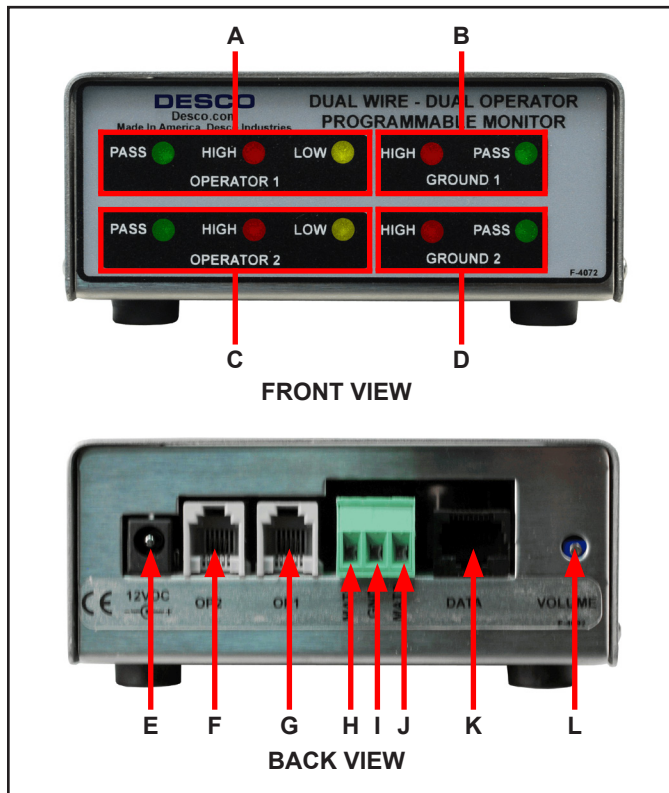

Figure 2. Dual-Wire Dual Operator Monitor features and components

A. Operator 1 Status LEDs: When the green LED is illuminated, operator 1 is properly grounded. When the LED is illuminated red or yellow and the alarm sounds, operator 1 is not properly grounded.

B. Worksurface 1 Status LEDs: When the green LED is illuminated, worksurface 1 is properly grounded. When the red LED is illuminated and the alarm sounds, worksurface 1 is not properly grounded.

C. Operator 2 Status LEDs: When the green LED is illuminated, operator 2 is properly grounded. When the LED is illuminated red or yellow and the alarm sounds, operator 2 is not properly grounded.

D. Worksurface 2 Status LEDs: When the green LED is illuminated, worksurface 2 is properly grounded. When the LED is illuminated red and the alarm sounds, worksurface 2 is not properly grounded.

E. Power Jack: Connect to the included 12VDC power adapter.

F. Operator 2 Remote Jack: Connect to the black operator remote cable.

G. Operator 1 Remote Jack: Connect to the white operator remote cable.

H. Monitored Mat 1 Terminal: Monitors a worksurface mat for proper dissipative resistance and static charges. Connect the white mat monitor cord here.

I. Ground Terminal: Common ground point for the monitor. Connect to the green and yellow monitor ground cord.

J. Monitored Mat 2 Terminal: Monitors a worksurface mat for proper dissipative resistance and static charges. Connect the black monitor cord here.

K. Data Output: For manufacturer use only.

L. Alarm Audible Adjustment: Turn the trimpot counter-clockwise to increase the audible alarm volume and clockwise to decrease it.

Installation

1. Determine the mounting location of the Dual-Wire Dual Operator Monitor. The front panel should be visible to both operators.
2. Determine the mounting locations of the operator remotes. Be sure to install the remotes at a distance that enables the 10 foot leads to reach the back of the monitor.
3. Install tinned wire ends of the mat cords to their appropriate screw terminal block located at the back of the monitor.
4. Attach the worksurface mats to ground using the green mat ground cord. Install the ring terminal end of the cord to an appropriate ground point. Attach the snaps terminals to the snaps on the worksurface mat.
5. Install the tinned wire end of the green and yellow monitor ground cord to the ground terminal located at the back of the monitor. Install its ring terminal to an appropriate ground point. Be sure to use a different ground point than the one used for the mats. The face plate screw of a grounded AC wall outlet may provide a convenient connection point.
6. Route the mat cords from the back of the monitor to the snaps on worksurface mats. The white cord is for worksurface mat #1. The black cord is for worksurface mat #2.
7. Insert the operator remote cables into their appropriate jacks located at the back of the monitor. The white cable is for operator #1. The black cable is for operator #2.
8. Connect the power adapter to the power jack located at the back of the monitor. Plug the power adapter into a proper AC power outlet. The monitor is now powered.

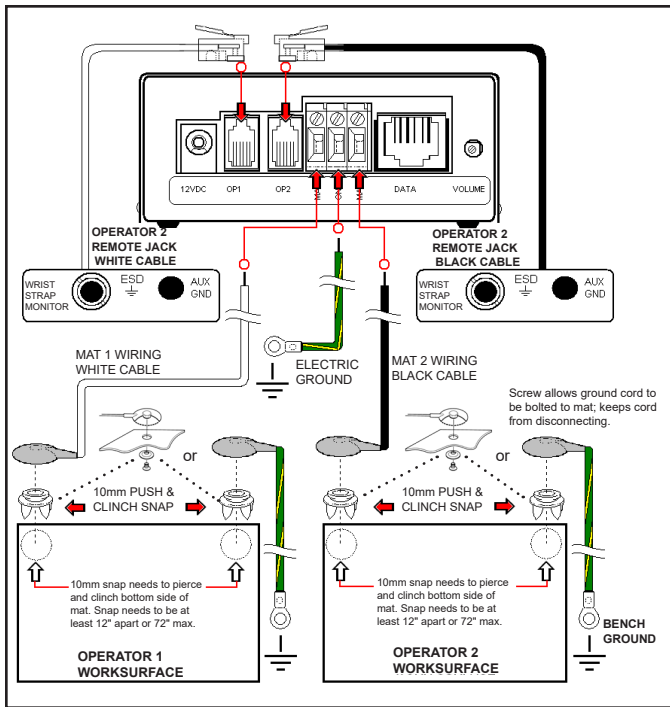

Figure 3. Installing the Dual-Wire Dual Operator Monitor

Operation

1. Monitoring of the operators will remain in the STANDBY condition until a wrist cord is plugged into the operator remote. STANDBY mode is indicated by a blinking yellow operator LED.
2. Plug a wrist strap cord, not attached to the wristband, into the monitored jack labeled WRIST STRAP MONITOR located on the remote. This automatically activates the selected operator channel. The corresponding operator LED should illuminate red and the alarm should sound on the monitor.
3. Remove the charges from your body by making contact with a properly grounded ESD worksurface.
4. Snap the cord to the wristband, and fit it snugly onto your wrist. This should silence the audible alarm and cause the corresponding operator LED to switch from red to green. If this does not happen, examine the wrist cord for continuity or damage and your wrist band to ensure that it is securely fit. If you have dry skin, apply an approved dissipative hand lotion such as [Menda Reztore® ESD Hand Lotion](#).
5. The AUX GND jack located on the operator remote is a grounded and unmonitored connection for guests. It must be used with a banana plug wrist cord and single-wire wristband.

NOTE: Worksurface must have a conductive layer such as Dual Layer Rubber or Dissipative 3-Layer Vinyl or Micastat® Dissipative Laminate with conductive buried layers. Desco continuous monitors are not recommended for use with homogeneous matting.

SETTING THE OPERATOR TEST VOLTAGE AND TEST LIMIT

The Dual-Wire Dual Operator Monitor's operator test voltage and high test limit can be set to different values. The operator test voltage can be set to either +5 V or +8 V, and the operator high test limit can be set to either 10 megohms or 35 megohms. The default voltage is +8 V, and the default operator high test limit is 35 megohms. These settings are controlled by a set of 3 switches located inside the monitor's enclosure.

NOTE: Desco recommends re-calibration of the monitor should either setting be changed. See the "Calibration" section for more information.

To gain access to these switches, remove the monitor's cover and position the monitor so the PCB matches the orientation shown in Figure 4. Switches SW1 and SW2 control the operator test voltage. Switch SW3 controls the operator high test limit.

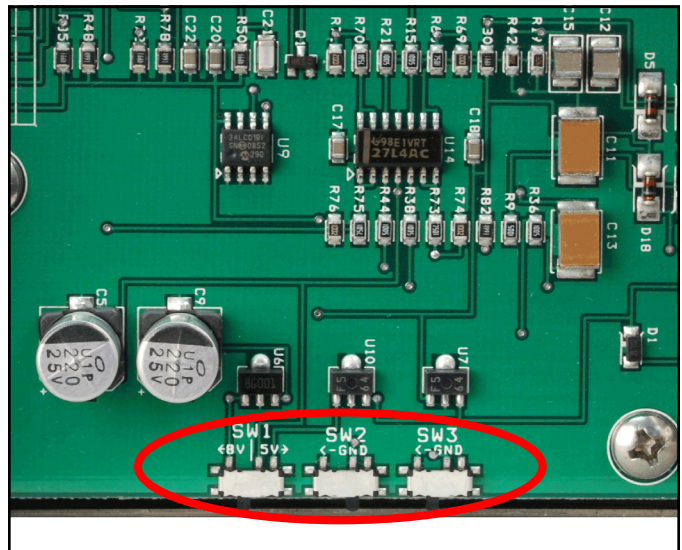

Figure 4. Switches SW1, SW2 and SW3 inside the monitor's enclosure

Operator Test Voltage

+5V

SW1 Position: RIGHT
SW2 Position: LEFT

+8V

SW1 Position: LEFT
SW2 Position: RIGHT

Operator High Test Limit

10 megohms

SW3 Position: RIGHT

35 megohms

SW3 Position: LEFT

Calibration

The Dual-Wire Dual Operator Monitor is calibrated to standards traceable to NIST. Frequency of recalibration should be based on the critical nature of those ESD sensitive items handled and the risk of failure for the ESD protective equipment and materials. In general, we recommend that calibration be performed annually.

Use the EMIT [50524](#) Limit Comparator for Dual-Wire Monitors to perform periodic testing (once every 6-12 months) of the Dual-Wire Dual Operator Monitor. The Limit Comparator can be used on the shop floor within a few minutes virtually eliminating downtime, verifying that the monitor is operating within tolerances.

See [TB-6542](#) for more information.



Figure 5. EMIT 50524 Limit Comparator for Dual-Wire Monitors

Specifications

Input Voltage and Frequency (External Adapter)	AC/DC Power Adapter Power Input: 100-240 VAC, 50/60 Hz Power Output: 12 VDC @ 0.50 A Cable Length: 5 ft. (1.5 m)
Operating Temperature	50 to 95 °F (10 to 35 °C)
Environmental Requirements	Indoor use only at altitudes less than 6500 ft. (2 km) Maximum relative humidity of 80 % up to 85 °F (30 °C) decreasing linearly to 50 % @ 85 °F (30 °C)
Dimensions (Monitor)	4.4" x 4.7" x 2.1" (112 mm x 119 mm x 53 mm)
Weight (Monitor)	1.1 lbs. (0.5 kg)
Operator Test Range	1.91 megohms to 35 megohms (default) or 1.91 megohms to 10 megohms (±10 %)
Worksurface Test Limit*	3.5 megohms (±10 %)
Operator Test Voltage	8 V (default) or 5 V
Worksurface Test Voltage	200 mV
Country of Origin	United States of America

*The worksurface mat must have a conductive layer such as Dual Layer Rubber or Dissipative 3-Layer Vinyl with conductive buried layers. Desco workstation monitors are not recommended for use with homogeneous matting.

ANSI/ESD S20.20 requires the use of a surface resistance meter for periodic verification of a worksurface's resistance-to-ground (Rtg). Constant monitors may not be used as a substitute for this requirement.

Limited Warranty, Warranty Exclusions, Limit of Liability and RMA Request Instructions

See the Desco Warranty - Desco.com/Limited-Warranty.aspx

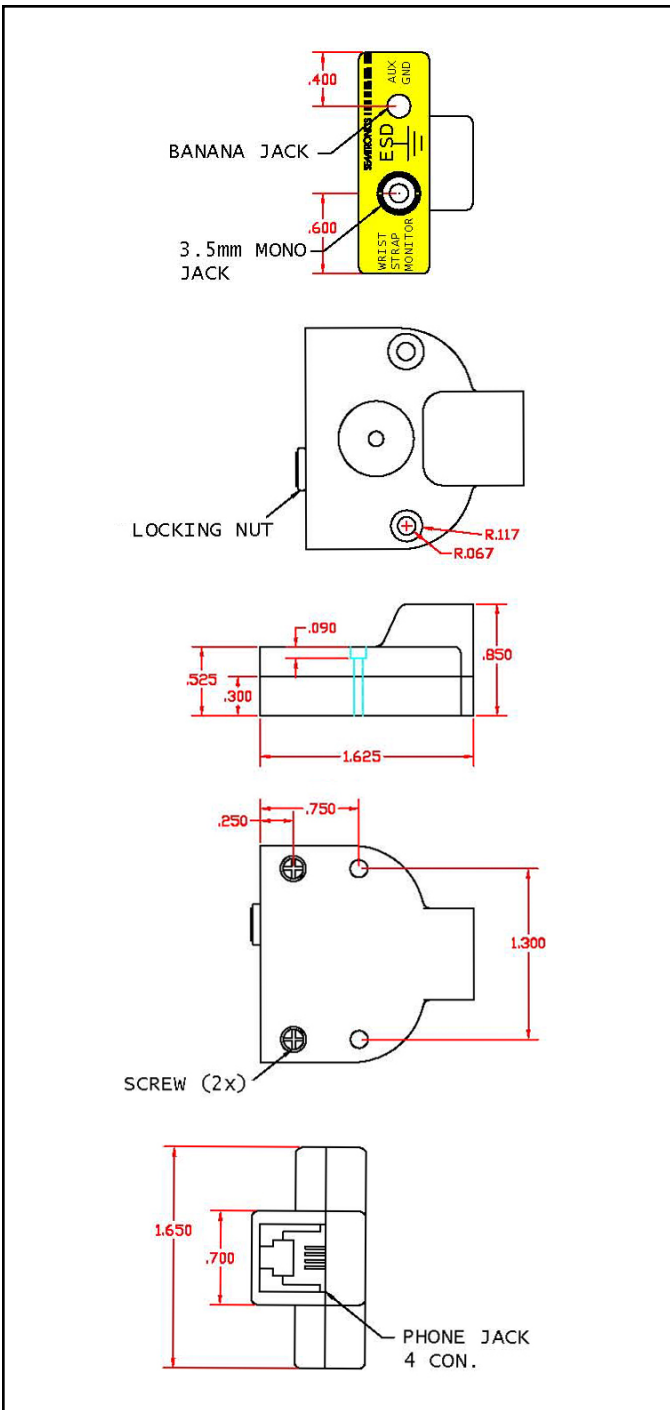

Figure 7. Operator Remote dimensions

Replacement remotes are available as Desco items 50525 and 50526

Компания «Life Electronics» занимается поставками электронных компонентов импортного и отечественного производства от производителей и со складов крупных дистрибьюторов Европы, Америки и Азии.

С конца 2013 года компания активно расширяет линейку поставок компонентов по направлению коаксиальный кабель, кварцевые генераторы и конденсаторы (керамические, пленочные, электролитические), за счёт заключения дистрибьюторских договоров

Мы предлагаем:

- Конкурентоспособные цены и скидки постоянным клиентам.
- Специальные условия для постоянных клиентов.
- Подбор аналогов.
- Поставку компонентов в любых объемах, удовлетворяющих вашим потребностям.
- Приемлемые сроки поставки, возможна ускоренная поставка.
- Доставку товара в любую точку России и стран СНГ.
- Комплексную поставку.
- Работу по проектам и поставку образцов.
- Формирование склада под заказчика.
- Сертификаты соответствия на поставляемую продукцию (по желанию клиента).
- Тестирование поставляемой продукции.
- Поставку компонентов, требующих военную и космическую приемку.
- Входной контроль качества.
- Наличие сертификата ISO.

В составе нашей компании организован Конструкторский отдел, призванный помогать разработчикам, и инженерам.

Конструкторский отдел помогает осуществить:

- Регистрацию проекта у производителя компонентов.
- Техническую поддержку проекта.
- Защиту от снятия компонента с производства.
- Оценку стоимости проекта по компонентам.
- Изготовление тестовой платы монтаж и пусконаладочные работы.



Тел: +7 (812) 336 43 04 (многоканальный)
Email: org@lifeelectronics.ru