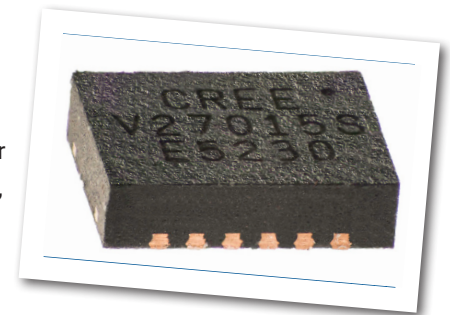


# CGHV27015S

15 W, DC - 6.0 GHz, 50 V, GaN HEMT

Cree's CGHV27015S is an unmatched, gallium nitride (GaN) high electron mobility transistor (HEMT) designed specifically for high efficiency, high gain and wide bandwidth capabilities, which makes the CGHV27015S ideal for LTE, 4G Telecom and BWA amplifier applications. The CGHV27015S GaN HEMT device is unmatched so it is suitable for power amplifier applications from 10MHz through 6000 MHz, such as tactical communications, CATV, UAV data links, as well as a driver stage amplifier for RADAR, EW, and SatCom devices. At a V<sub>dd</sub> of 50 V, the device provide 2.5W of average power or 15W of peak power. At a V<sub>dd</sub> of 28V, the device provides 1W of average power and 7W of peak power. The transistor is available in a 3mm x 4mm, surface mount, dual-flat-no-lead (DFN) package.



Package Type: 3x4 DFN  
PN: CGHV27015S

## Typical Performance 2.4-2.7 GHz (T<sub>c</sub> = 25°C), 50 V

Parameter	2.4 GHz	2.5 GHz	2.6 GHz	2.7 GHz	Units
Small Signal Gain	23	22	21.7	21.2	dB
Adjacent Channel Power @ P <sub>OUT</sub> = 2.5 W	-36.7	-40.7	-42.4	-42.5	dBc
Drain Efficiency @ P <sub>OUT</sub> = 2.5 W	35.9	33.5	30.4	30.2	%
Input Return Loss	-9.312	-9.6	-8.6	-7.8	dB

Note:  
Measured in the CGHV27015S-AMP1 application circuit.  
Under 7.5 dB PAR single carrier WCDMA signal test model 1 with 64 DPCH.

## Features for 50 V in CGHV27015S-AMP1

- 2.4 - 2.7 GHz Operation
- 15 W Typical Output Power
- 21 dB Gain at 2.5 W P<sub>AVE</sub>
- -38 dBc ACLR at 2.5 W P<sub>AVE</sub>
- 32% efficiency at 2.5 W P<sub>AVE</sub>
- High degree of APD and DPD correction can be applied

Large Signal Models Available for ADS and MWO

## Absolute Maximum Ratings (not simultaneous) at 25°C Case Temperature

Parameter	Symbol	Rating	Units	Notes
Drain-Source Voltage	$V_{DS}$	125	Volts	25°C
Gate-to-Source Voltage	$V_{GS}$	-10, +2	Volts	25°C
Storage Temperature	$T_{STG}$	-65, +150	°C	
Operating Junction Temperature	$T_J$	225	°C	
Maximum Forward Gate Current	$I_{GMAX}$	2	mA	25°C
Maximum Drain Current <sup>1</sup>	$I_{DMAX}$	0.9	A	25°C
Soldering Temperature <sup>2</sup>	$T_S$	245	°C	
Case Operating Temperature <sup>3</sup>	$T_C$	-40, +150	°C	
Thermal Resistance, Junction to Case <sup>4</sup>	$R_{\theta JC}$	11.1	°C/W	85°C

Note:

<sup>1</sup> Current limit for long term, reliable operation

<sup>2</sup> Refer to the Application Note on soldering at [www.cree.com/rf/document-library](http://www.cree.com/rf/document-library)

<sup>3</sup>  $T_C$  = Case temperature for the device. It refers to the temperature at the ground tab underneath the package. The PCB will add additional thermal resistance. See also, the Power Dissipation De-rating Curve on page 7.

<sup>4</sup> Measured for the CGHV27015S at  $P_{DISS} = 5$  W

<sup>5</sup> The  $R_{\theta TH}$  for Cree's demonstration amplifier, CGHV27015S-AMP1, with 31 x 0.011 via holes designed on a 20 mil thick Rogers 4350 PCB, is 3.9°C. The total  $R_{\theta TH}$  from the heat sink to the junction is 11.1°C + 3.9°C = 15°C/W.

## Electrical Characteristics ( $T_C = 25^\circ\text{C}$ )

Characteristics	Symbol	Min.	Typ.	Max.	Units	Conditions
<b>DC Characteristics<sup>1</sup></b>						
Gate Threshold Voltage	$V_{GS(th)}$	-3.8	-3.0	-2.3	$V_{DC}$	$V_{DS} = 10$ V, $I_D = 2$ mA
Gate Quiescent Voltage	$V_{GS(Q)}$	-	-2.6	-	$V_{DC}$	$V_{DS} = 50$ V, $I_D = 60$ mA
Saturated Drain Current	$I_{DS}$	1.48	1.78	-	A	$V_{DS} = 6.0$ V, $V_{GS} = 2.0$ V
Drain-Source Breakdown Voltage	$V_{(BR)DSS}$	150	-	-	$V_{DC}$	$V_{GS} = -8$ V, $I_D = 2$ mA
<b>RF Characteristics<sup>2,3</sup> (<math>T_C = 25^\circ\text{C}</math>, <math>F_0 = 2.7</math> GHz unless otherwise noted)</b>						
Gain	G	-	21.6	-	dB	$V_{DD} = 50$ V, $I_{DQ} = 60$ mA, $P_{IN} = 10$ dBm
Output Power <sup>4</sup>	$P_{OUT}$	-	41.9	-	dBm	$V_{DD} = 50$ V, $I_{DQ} = 60$ mA, $P_{IN} = 25$ dBm
Drain Efficiency <sup>4</sup>	$\eta$	-	67	-	%	$V_{DD} = 50$ V, $I_{DQ} = 60$ mA, $P_{IN} = 25$ dBm
Output Mismatch Stress <sup>4</sup>	VSWR	-	10 : 1	-	$\Psi$	No damage at all phase angles, $V_{DD} = 50$ V, $I_{DQ} = 60$ mA, $P_{IN} = 25$ dBm
<b>Dynamic Characteristics</b>						
Input Capacitance <sup>5</sup>	$C_{GS}$	-	3.15	-	pF	$V_{DS} = 50$ V, $V_{gs} = -8$ V, $f = 1$ MHz
Output Capacitance <sup>5</sup>	$C_{DS}$	-	1.06	-	pF	$V_{DS} = 50$ V, $V_{gs} = -8$ V, $f = 1$ MHz
Feedback Capacitance	$C_{GD}$	-	0.058	-	pF	$V_{DS} = 50$ V, $V_{gs} = -8$ V, $f = 1$ MHz

Notes:

<sup>1</sup> Measured on wafer prior to packaging

<sup>2</sup> Scaled from PCM data

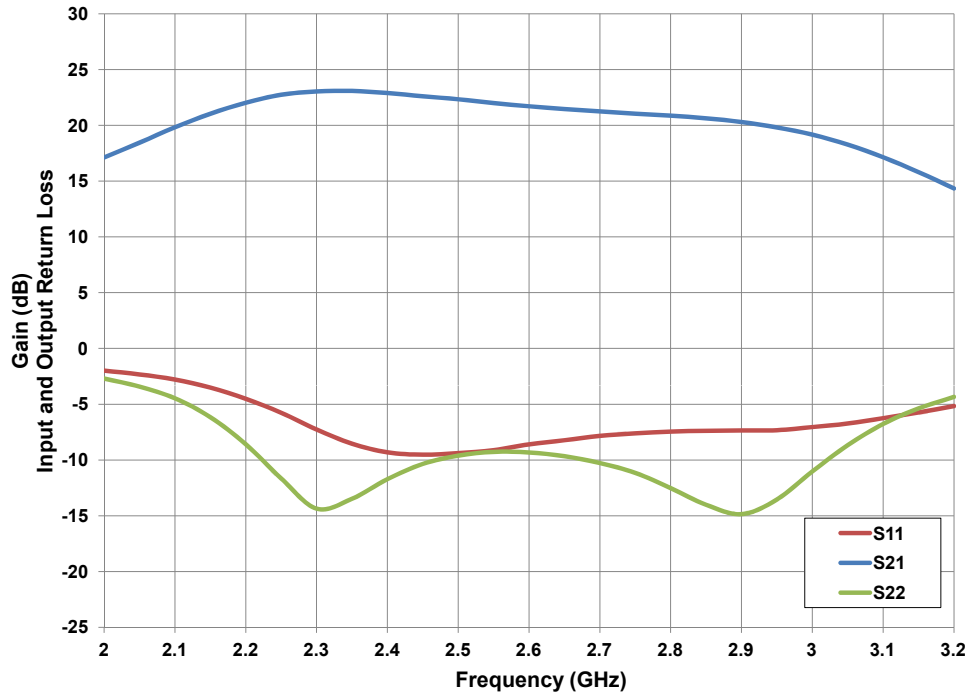
<sup>3</sup> Measured in Cree's production test fixture. This fixture is designed for high volume test at 2.7 GHz

<sup>4</sup> Un-modulated pulsed signal, 100  $\mu$ s, 10% duty cycle

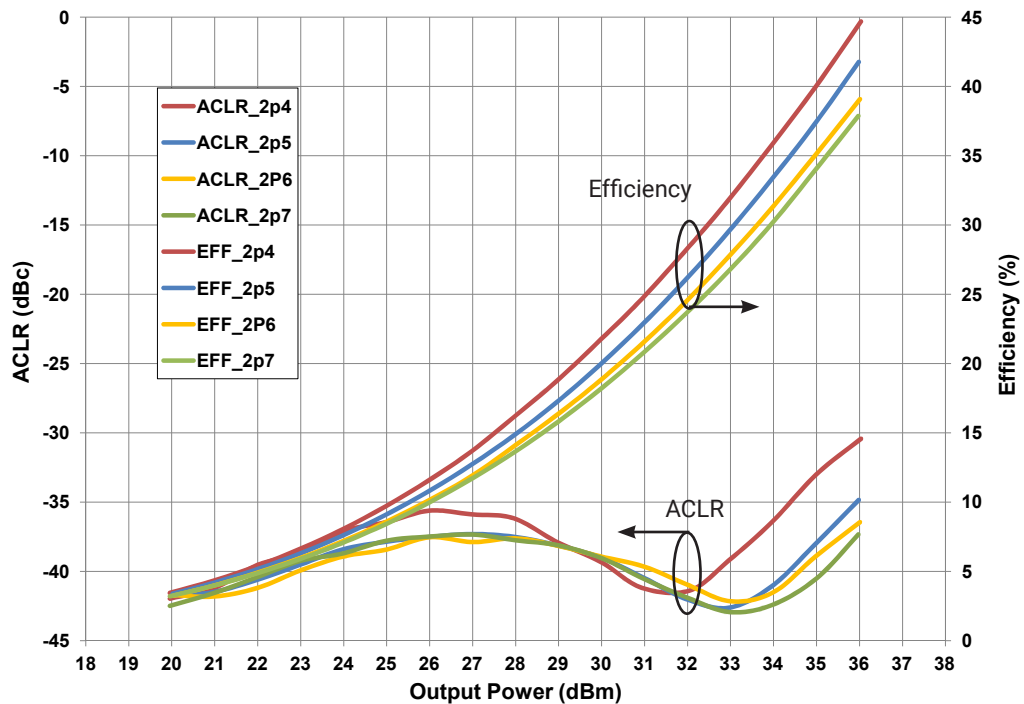
<sup>5</sup> Includes package and internal matching components

## Typical Performance in Application Circuit CGHV27015S-AMP1

**Figure 1. - Small Signal Gain and Return Losses vs Frequency**  
 $V_{DD} = 50\text{ V}, I_{DQ} = 60\text{ mA}$

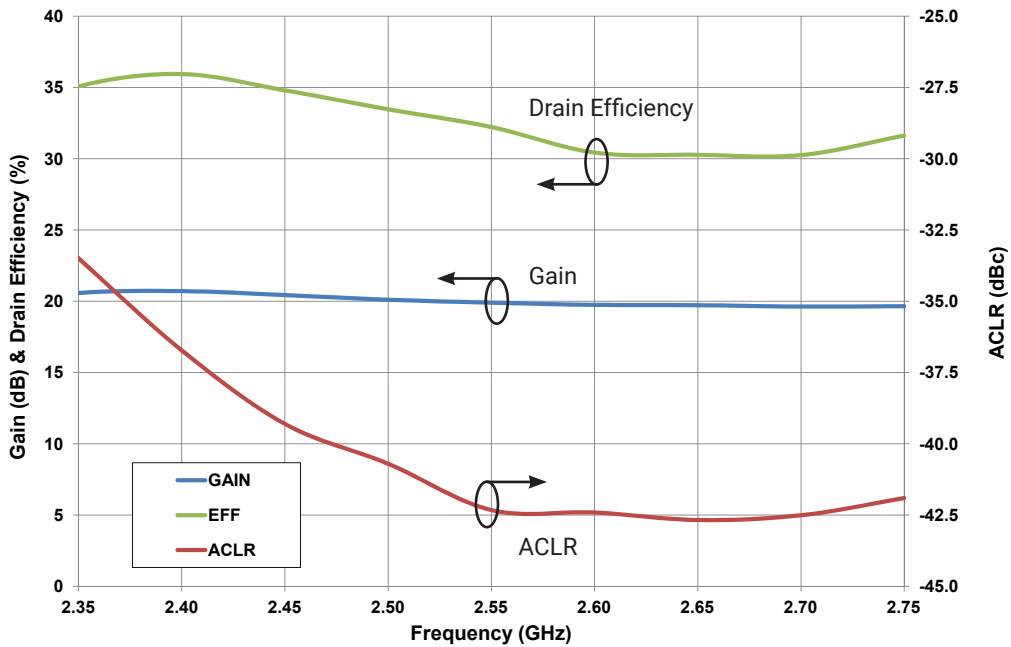


**Figure 2. - Typical Drain Efficiency and ACLR vs. Output Power**  
 $V_{DD} = 50\text{ V}, I_{DQ} = 60\text{ mA}, 1\text{ Carrier WCDMA}, PAR = 7.5\text{ dB}$



## Typical Performance in Application Circuit CGHV27015S-AMP1

**Figure 3. - Typical Gain, Drain Efficiency and ACLR vs Frequency**  
 $V_{DD} = 50\text{ V}$ ,  $I_{DQ} = 60\text{ mA}$ ,  $P_{AVE} = 2.5\text{ W}$ , 1 Carrier WCDMA, PAR = 7.5 dB



## Electrostatic Discharge (ESD) Classifications

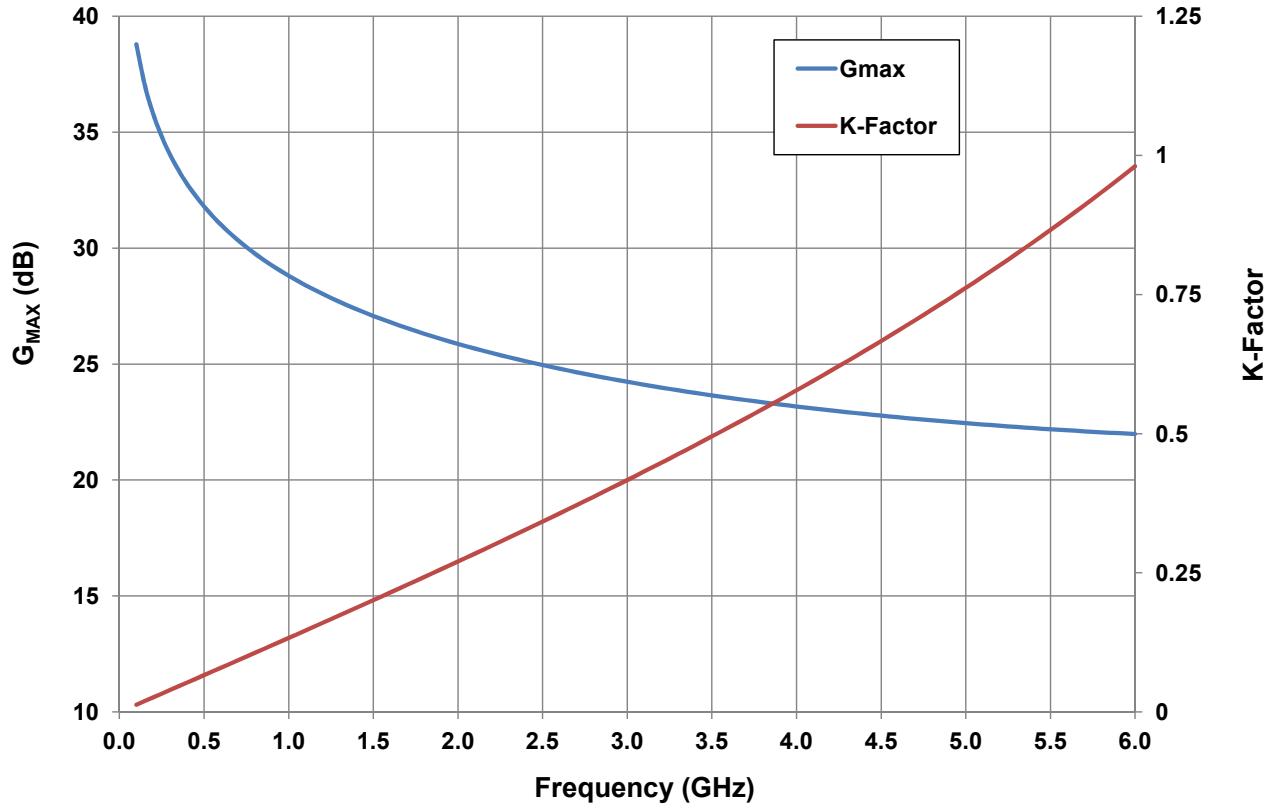
Parameter	Symbol	Class	Test Methodology
Human Body Model	HBM	1A (> 250 V)	JEDEC JESD22 A114-D
Charge Device Model	CDM	2 (125 V to 250 V)	JEDEC JESD22 C101-C

## Moisture Sensitivity Level (MSL) Classification

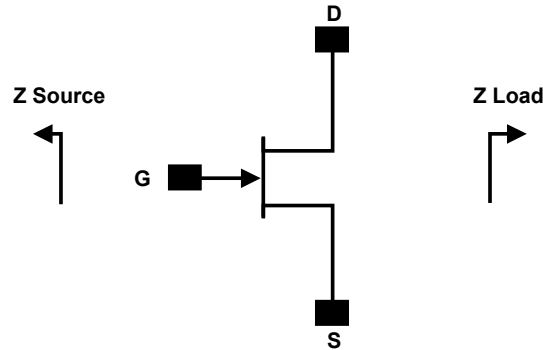
Parameter	Symbol	Level	Test Methodology
Moisture Sensitivity Level	MSL	3 (168 hours)	IPC/JEDEC J-STD-20

## Typical Performance

**$G_{MAX}$  and K-Factor vs Frequency**  
 $V_{DD} = 50\text{ V}$ ,  $I_{DQ} = 60\text{ mA}$ ,  $T_{case} = 25^\circ\text{C}$



## Source and Load Impedances for Application Circuit CGHV27015S-AMP1



Frequency (MHz)	Z Source	Z Load
2400	$7.9 + j2.14$	$15.8 + j43.1$
2500	$8 + j2.9$	$18.3 + j43.7$
2600	$7.9 + j3.6$	$19.7 + j43.4$
2700	$7.7 - j4.4$	$19.7 + j43.4$

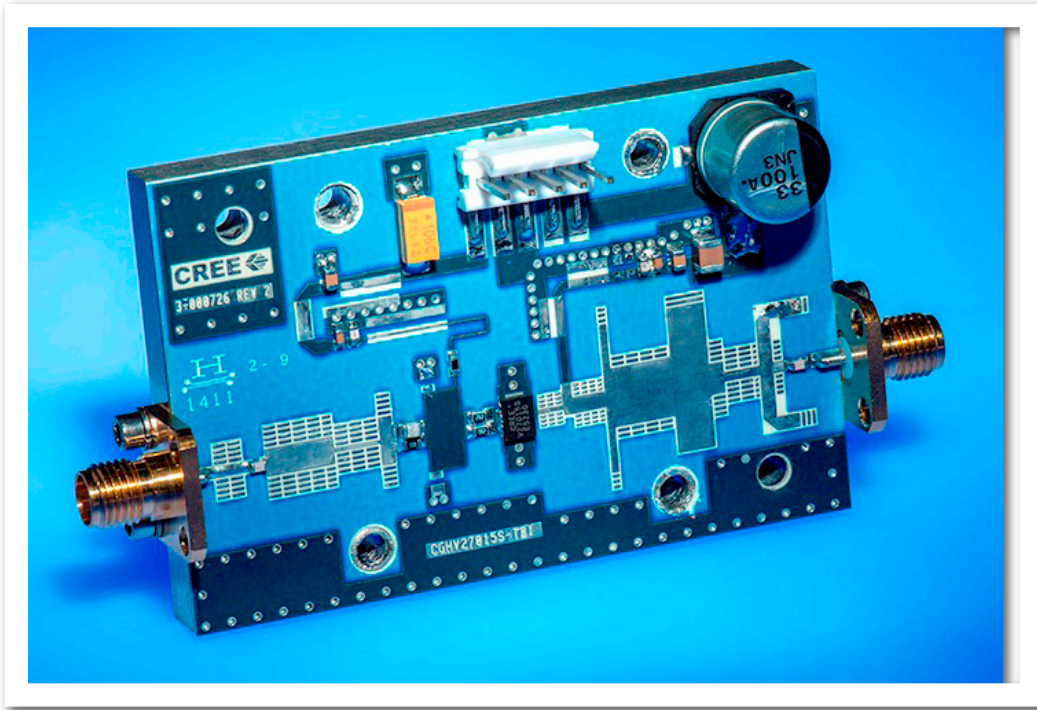
Note<sup>1</sup>:  $V_{DD} = 50\text{ V}$ ,  $I_{DQ} = 60\text{ mA}$  in the DFN package.

Note<sup>2</sup>: Impedances are extracted from the CGHV27015S-AMP1 application circuit and are not source and load pull data derived from the transistor.

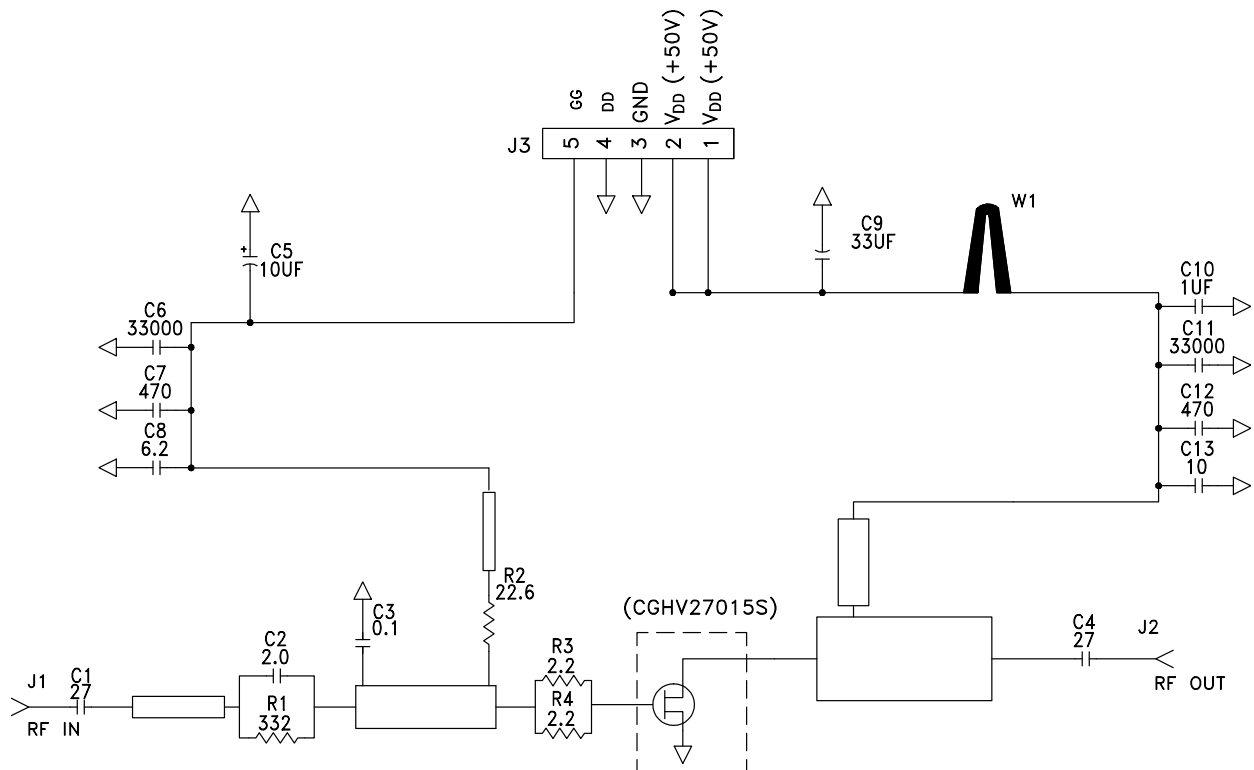
## CGHV27015S-AMP1 Application Circuit Bill of Materials

Designator	Description	Qty
R1	RES, 332,OHM, +/- 1%, Vishay	1
R2	RES, 22.6,OHM, +/- 1%, 1/16W, 0603	1
R3, R4	RES, 2.2,OHM, +/- 1%, 1/16W, 0603	1
C1, C4	CAP, 27pF, +/- 5%, 0603, ATC	2
C2	CAP, 2.0pF,+/-0.1pF, 0603 ATC	1
C3	CAP, 0.1pF,+/-0.05 pF, 0603, ATC	2
C8	CAP, 6.2pF, +/-0.1pF, 0603, ATC	1
C13	CAP, 10pF +/-5%, 0603, ATC	1
C6, C11	CAP, 33000pF, 0805, ATC	2
C7, C12	CAP, 470PF, 5%, 100V, 0603,	2
C10	CAP, 1.0UF, 100V, 10%, X7R, 1210	1
C5	CAP 10UF 16V TANTALUM	1
C9	CAP, 33UF, 20%, G CASE	1
J1, J2	CONN, SMA, PANEL MOUNT JACK, FLANGE, 4-HOLE, BLUNT POST	2
J3	HEADER RT>PLZ .1CEN LK 5POS	1
Q1	CGHV27015S, DFN	1

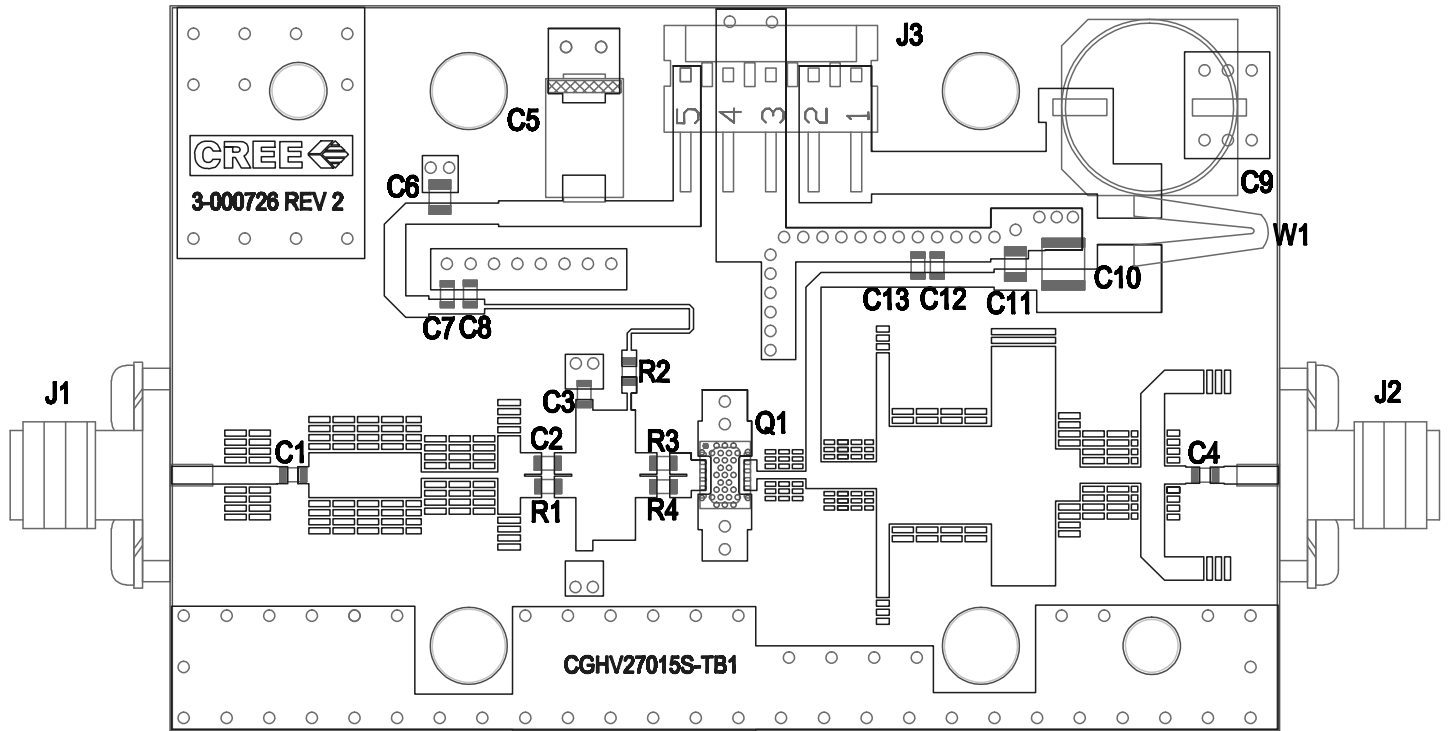
## CGHV27015S-AMP1 Application Circuit, 50 V



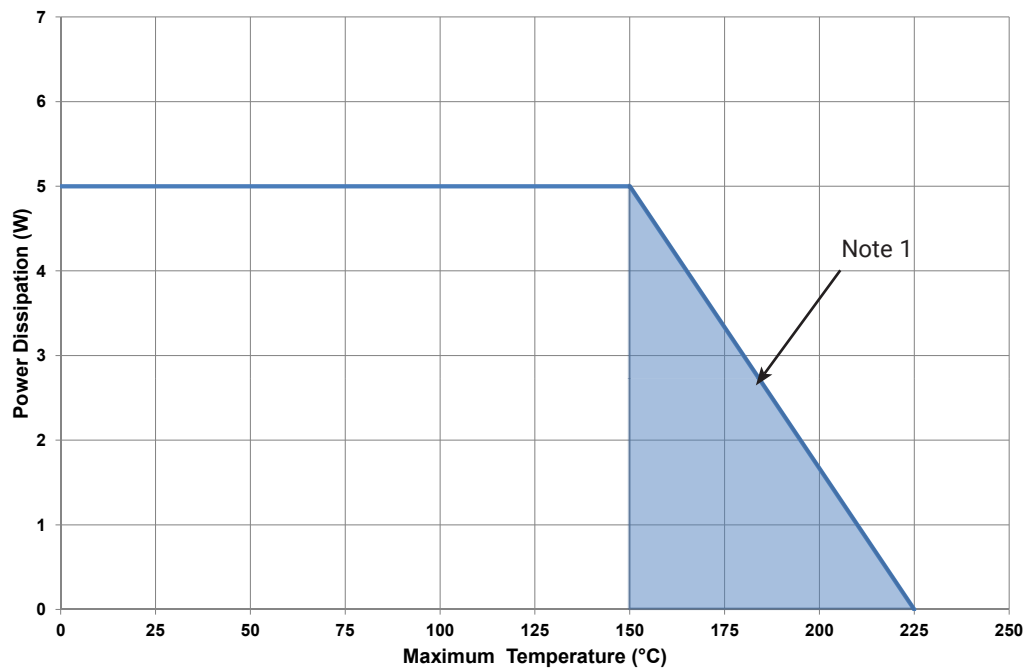
## CGHV27015S-AMP1 Application Circuit Schematic, 50 V



## CGHV27015S-AMP1 Application Circuit, 50 V



## CGHV27015S-AMP1 Power Dissipation De-rating Curve

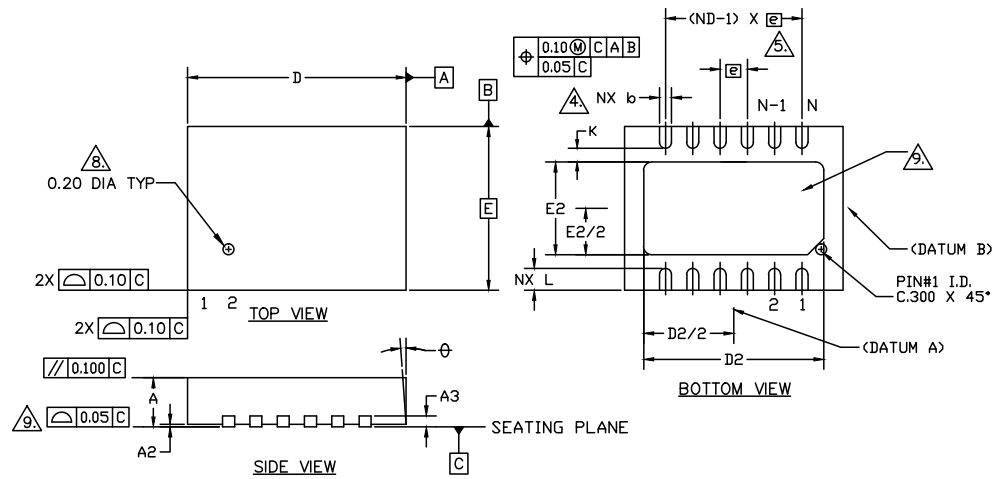


Note 1. Area exceeds Maximum Case Temperature (See Page 2)



## Product Dimensions CGHV27015S (Package 3 x 4 DFN)

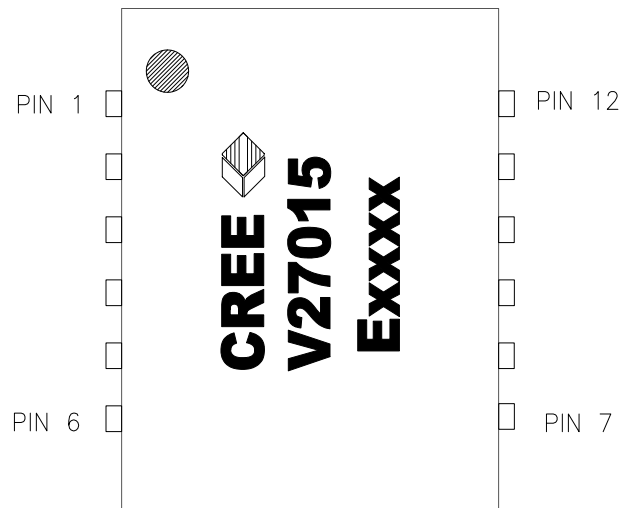
A3	0.203 REF.			
$\theta$	0	12	2	
D	4.00 BSC			
E	3.00 BSC			
$\square$	0.50 BSC			
N	12			3
ND	6			$\triangle$
L	0.35	0.40	0.45	
b	0.17	0.22	0.27	$\triangle$
D2	3.20	3.30	3.40	
E2	1.60	1.7	1.80	
K	0.20			



### NOTES :

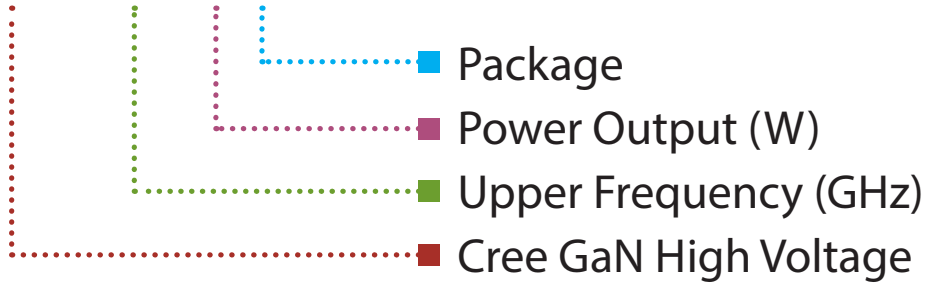
- DIMENSIONING AND TOLERANCING CONFORM TO ASME Y14.5M - 1994.
- ALL DIMENSIONS ARE IN MILLIMETERS,  $\theta$  IS IN DEGREES.
- N IS THE TOTAL NUMBER OF TERMINALS.
- $\triangle$  DIMENSION b APPLIES TO METALLIZED TERMINAL AND IS MEASURED BETWEEN .15 AND .30mm FROM TERMINAL TIP.
- $\triangle$  ND REFERS TO THE NUMBER OF TERMINALS ON D SIDE
- MAXIMUM PACKAGE WARPAGE IS .05 mm.
- MAXIMUM ALLOWABLE BURRS IS .076 mm IN ALL DIRECTIONS.
- $\triangle$  PIN #1 ID ON TOP WILL BE LASER MARKED.
- $\triangle$  UNILATERAL COPLANARITY ZONE APPLIES TO THE EXPOSED HEAT SINK SLUG AS WELL AS THE TERMINALS.
- THIS DRAWING CONFORMS TO JEDEC REGISTERED OUTLINE MO-229.
- ALL PLATED SURFACES ARE AU.

Pin	Input/Output
1	GND
2	NC
3	RF IN
4	RF IN
5	NC
6	GND
7	GND
8	NC
9	RF OUT
10	RF OUT
11	NC
12	GND



Note: Leadframe finish for 3x4 DFN package is Nickel/Palladium/Gold. Gold is the outer layer.

### CGHV27015S



Parameter	Value	Units
Upper Frequency <sup>1</sup>	2.7	GHz
Power Output	15	W
Package	Surface Mount	-

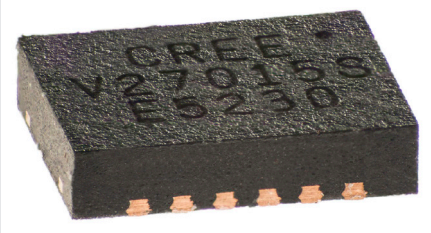
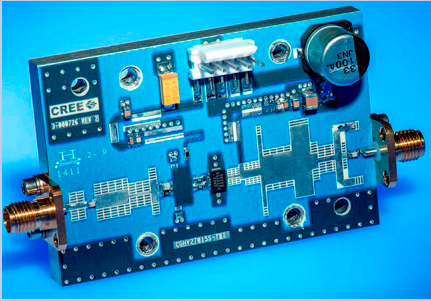
**Table 1.**

**Note<sup>1</sup>:** Alpha characters used in frequency code indicate a value greater than 9.9 GHz. See Table 2 for value.

Character Code	Code Value
A	0
B	1
C	2
D	3
E	4
F	5
G	6
H	7
J	8
K	9
Examples:	1A = 10.0 GHz 2H = 27.0 GHz

**Table 2.**

## Product Ordering Information

Order Number	Description	Unit of Measure	Image
CGHV27015S	GaN HEMT	Each	
CGHV27015S-AMP1	Test board with GaN HEMT installed	Each	
CGHV27015S-TR	Delivered in Tape and Reel	250 parts / reel	



## Disclaimer

Specifications are subject to change without notice. Cree, Inc. believes the information contained within this data sheet to be accurate and reliable. However, no responsibility is assumed by Cree for any infringement of patents or other rights of third parties which may result from its use. No license is granted by implication or otherwise under any patent or patent rights of Cree. Cree makes no warranty, representation or guarantee regarding the suitability of its products for any particular purpose. "Typical" parameters are the average values expected by Cree in large quantities and are provided for information purposes only. These values can and do vary in different applications and actual performance can vary over time. All operating parameters should be validated by customer's technical experts for each application. Cree products are not designed, intended or authorized for use as components in applications intended for surgical implant into the body or to support or sustain life, in applications in which the failure of the Cree product could result in personal injury or death or in applications for planning, construction, maintenance or direct operation of a nuclear facility.

For more information, please contact:

Cree, Inc.  
4600 Silicon Drive  
Durham, North Carolina, USA 27703  
[www.cree.com/rf](http://www.cree.com/rf)

Sarah Miller  
Marketing  
Cree, RF Components  
1.919.407.5302

Ryan Baker  
Marketing & Sales  
Cree, RF Components  
1.919.407.7816

Tom Dekker  
Sales Director  
Cree, RF Components  
1.919.313.5639

Компания «Life Electronics» занимается поставками электронных компонентов импортного и отечественного производства от производителей и со складов крупных дистрибьюторов Европы, Америки и Азии.

С конца 2013 года компания активно расширяет линейку поставок компонентов по направлению коаксиальный кабель, кварцевые генераторы и конденсаторы (керамические, пленочные, электролитические), за счёт заключения дистрибьюторских договоров

Мы предлагаем:

- Конкурентоспособные цены и скидки постоянным клиентам.
- Специальные условия для постоянных клиентов.
- Подбор аналогов.
- Поставку компонентов в любых объемах, удовлетворяющих вашим потребностям.
- Приемлемые сроки поставки, возможна ускоренная поставка.
- Доставку товара в любую точку России и стран СНГ.
- Комплексную поставку.
- Работу по проектам и поставку образцов.
- Формирование склада под заказчика.
- Сертификаты соответствия на поставляемую продукцию (по желанию клиента).
- Тестирование поставляемой продукции.
- Поставку компонентов, требующих военную и космическую приемку.
- Входной контроль качества.
- Наличие сертификата ISO.

В составе нашей компании организован Конструкторский отдел, призванный помогать разработчикам, и инженерам.

Конструкторский отдел помогает осуществить:

- Регистрацию проекта у производителя компонентов.
- Техническую поддержку проекта.
- Защиту от снятия компонента с производства.
- Оценку стоимости проекта по компонентам.
- Изготовление тестовой платы монтаж и пусконаладочные работы.



Тел: +7 (812) 336 43 04 (многоканальный)

Email: [org@lifeelectronics.ru](mailto:org@lifeelectronics.ru)