



**RF360**  
**Europe GmbH**

## **Data sheet**

**Micro-acoustic extractor**  
**GNSS**

Series/type:	B8666
Ordering code:	B39162B8666L210
Date:	January 30, 2019
Version:	2.16

DCN: 80-PA243-252 Rev. B

RF360 products mentioned within this document are products of RF360 Europe GmbH and other subsidiaries of RF360 Holdings Singapore Pte. Ltd. (collectively, the "RF360 Subsidiaries").

RF360 Europe GmbH, Anzinger Str. 13, München, Germany

© 2019 RF360 Europe GmbH and/or its affiliated companies. All rights reserved.

These materials, including the information contained herein, may be used only for informational purposes by the customer. The RF360 Subsidiaries assume no responsibility for errors or omissions in these materials or the information contained herein. The RF360 Subsidiaries reserve the right to make changes to the product(s) or information contained herein without notice. The materials and information are provided on an AS IS basis, and the RF360 Subsidiaries assume no liability and make no warranty or representation, either expressed or implied, with respect to the materials, or any output or results based on the use, application, or evaluation of such materials, including, without limitation, with respect to the non-infringement of trademarks, patents, copyrights or any other intellectual property rights or other rights of third parties.

No use of this documentation or any information contained herein grants any license, whether express, implied, by estoppel or otherwise, to any intellectual property rights, including, without limitation, to any patents owned by QUALCOMM Incorporated or any of its subsidiaries.

Not to be used, copied, reproduced, or modified in whole or in part, nor its contents revealed in any manner to others without the express written permission of RF360 Europe GmbH.

Qualcomm is a trademark of Qualcomm Incorporated, registered in the United States and other countries. Other product and brand names may be trademarks or registered trademarks of their respective owners.

This technical data may be subject to U.S. and international export, re-export, or transfer ("export") laws. Diversion contrary to U.S. and international law is strictly prohibited.



RF360 Europe GmbH  
A Qualcomm – TDK Joint Venture

## Data sheet

Micro-acoustic extractor  
GNSS

Series/type:	B8666
Ordering code:	B39162B8666L210
Date:	January 30, 2019
Version:	2.16

DCN: 80-PA243-252 Rev. B

RF360 products mentioned within this document are products of RF360 Europe GmbH and other subsidiaries of RF360 Holdings Singapore Pte. Ltd. (collectively, the "RF360 Subsidiaries").

RF360 Holdings Singapore Pte. Ltd. is a joint venture of Qualcomm Global Trading Pte. Ltd. and EPCOS AG.

RF360 Europe GmbH, Anzinger Str. 13, München, Germany

© 2019 RF360 Europe GmbH and/or its affiliated companies. All rights reserved.

These materials, including the information contained herein, may be used only for informational purposes by the customer. The RF360 Subsidiaries assume no responsibility for errors or omissions in these materials or the information contained herein. The RF360 Subsidiaries reserve the right to make changes to the product(s) or information contained herein without notice. The materials and information are provided on an AS IS basis, and the RF360 Subsidiaries assume no liability and make no warranty or representation, either expressed or implied, with respect to the materials, or any output or results based on the use, application, or evaluation of such materials, including, without limitation, with respect to the non-infringement of trademarks, patents, copyrights or any other intellectual property rights or other rights of third parties.

No use of this documentation or any information contained herein grants any license, whether express, implied, by estoppel or otherwise, to any intellectual property rights, including, without limitation, to any patents owned by QUALCOMM Incorporated or any of its subsidiaries.

Not to be used, copied, reproduced, or modified in whole or in part, nor its contents revealed in any manner to others without the express written permission of RF360 Europe GmbH.

Qualcomm is a trademark of Qualcomm Incorporated, registered in the United States and other countries. Other product and brand names may be trademarks or registered trademarks of their respective owners.

This technical data may be subject to U.S. and international export, re-export, or transfer (“export”) laws. Diversion contrary to U.S. and international law is strictly prohibited.

## Table of contents

1	<a href="#">Application</a>	4
2	<a href="#">Features</a>	4
3	<a href="#">Package</a>	5
4	<a href="#">Pin configuration</a>	5
5	<a href="#">Matching circuit</a>	6
6	<a href="#">Characteristics ANT – GNSS</a>	7
7	<a href="#">Characteristics ANT – CELL</a>	8
8	<a href="#">Characteristics GNSS – CELL</a>	10
9	<a href="#">Maximum ratings</a>	11
10	<a href="#">Transmission coefficient ANT – GNSS</a>	12
11	<a href="#">Reflection coefficients ANT – GNSS</a>	13
12	<a href="#">Transmission coefficient ANT – CELL</a>	14
13	<a href="#">Reflection coefficients ANT – CELL</a>	15
14	<a href="#">Transmission coefficient GNSS – CELL</a>	16
15	<a href="#">Packing material</a>	17
16	<a href="#">Marking</a>	21
17	<a href="#">Soldering profile</a>	22
18	<a href="#">Annotations</a>	23
19	<a href="#">Cautions and warnings</a>	24
20	<a href="#">Important notes</a>	25

## 1 Application

- Premium-performance BeiDou/GPS/Glonass Extractor with single ended 50  $\Omega$  ports
- Ultra-low-loss acoustic structure
- Advanced fully-integrated multiplexer structure (no external matching needed)
- Using common antenna for BeiDou/GPS/Glonass and Cellular bands
- Placed between antenna and cellular front-end switches and filters
- Usable GNSS pass bands: 1559.05 -1563.144 MHz, 1574.42-1576.42 MHz, 1597.55-1605.89 MHz
- Usable CELL pass bands: 566 – 1510.9 MHz, 1710 – 2690 MHz, 3400 – 3800 MHz
- No switches and control lines required

## 2 Features

- Package size 1.7 mm  $\times$  1.3 mm
- Package height 0.5 mm
- Approximate weight 2 mg
- RoHS compatible
- Package for Surface Mount Technology (SMT)
- Ni/Au-plated terminals
- Electrostatic Sensitive Device (ESD)
- Moisture Sensitivity Level 3 (MSL3)

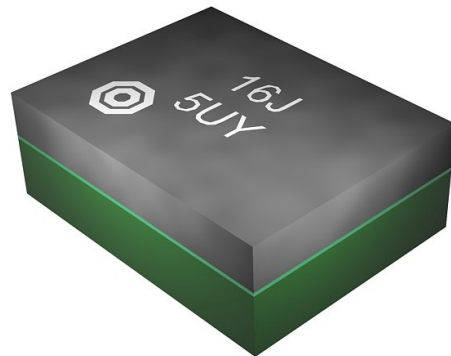

**Figure 1:** Picture of component with example of product marking.

3 Package

BOTTOM VIEW

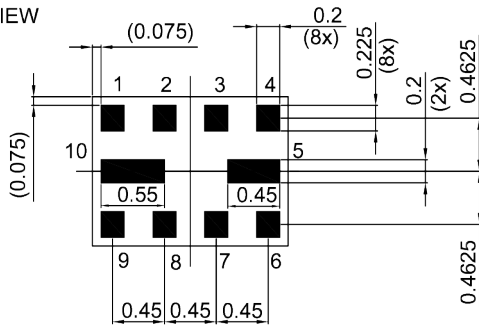

Pad and pitch tolerance ±0.05

SIDE VIEW

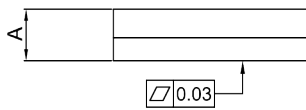

TOP VIEW

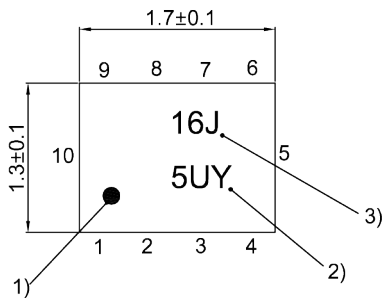

- 1) Marking for pad number 1
- 2) Example of encoded lot number
- 3) Example of encoded filter type number

Land pattern  
THRU VIEW

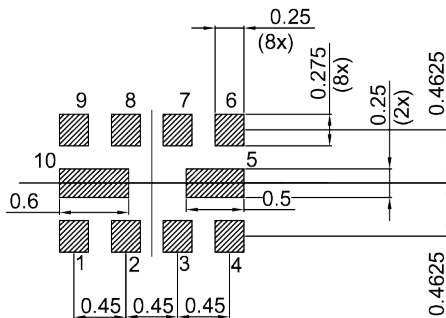

Landing pad tolerance -0.02

**Figure 2:** Drawing of package with package height A = 0.6 mm (max.). See Sec. Package information (p. 24).

4 Pin configuration

- 1 ANT
- 4 BeiDou/GPS/Glonass(GNSS)
- 9 CELL
- 2, 3, 5, 6, 7, 8, 10 Ground

## 5 Matching circuit

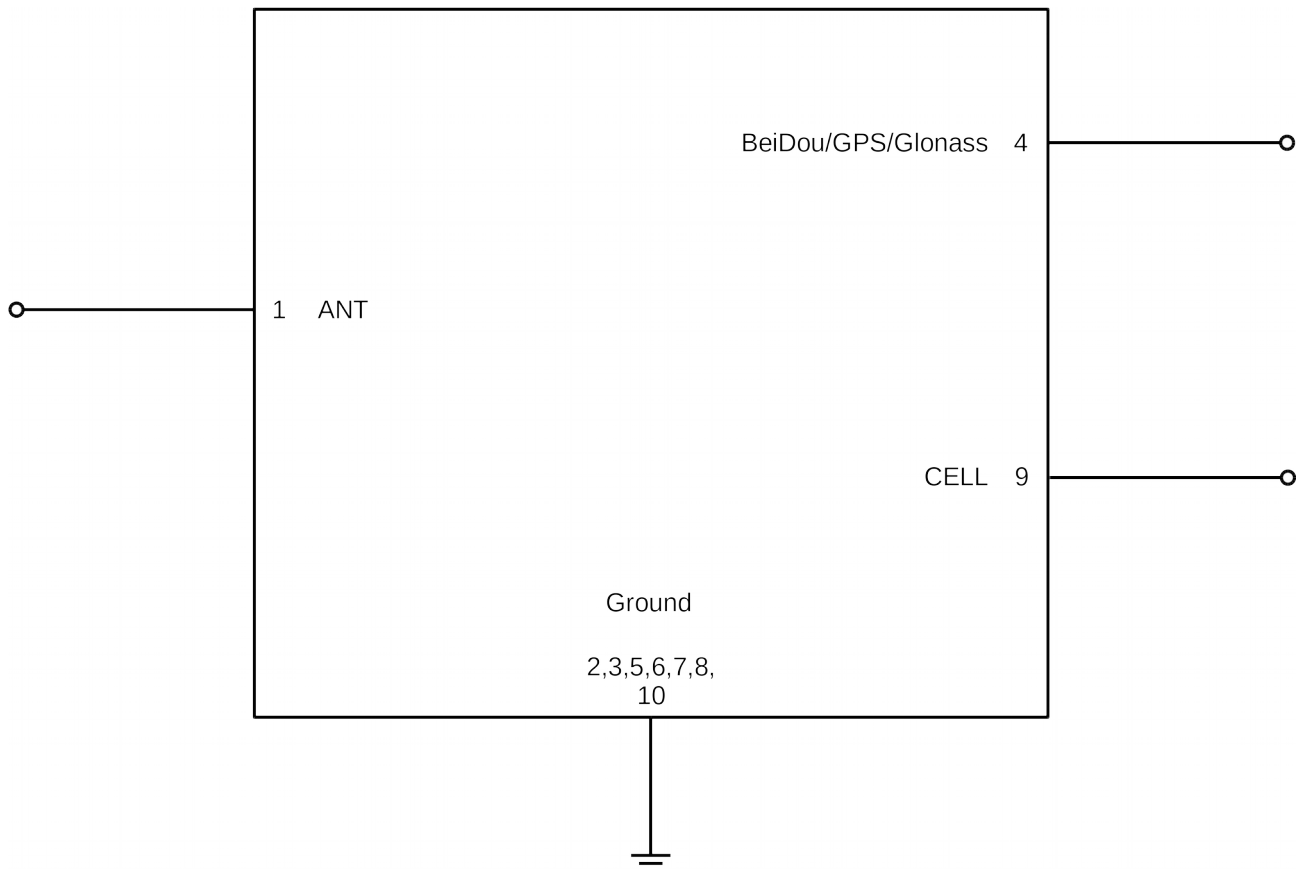

**Figure 3:** Schematic of matching circuit. No external matching components required.



## 6 Characteristics ANT – GNSS

Temperature range for specification	$T_{SPEC}$	= -30 °C ... +85 °C
ANT terminating impedance	$Z_{ANT}$	= 50 $\Omega$
GNSS terminating impedance	$Z_{GNSS}$	= 50 $\Omega$
CELL terminating impedance	$Z_{CELL}$	= 50 $\Omega$

Characteristics ANT – GNSS		min. for $T_{SPEC}$	typ. @ +25 °C	max. for $T_{SPEC}$		
<b>Insertion loss</b>	$\alpha$	1559.052... 1563.144 MHz	—	1.2	2.6	dB
		1574.42... 1576.42 MHz	—	0.8	1.5	dB
		1597.55... 1605.89 MHz	—	1.5	3.5	dB
<b>Attenuation</b>	$\alpha$	100... 777 MHz	33	38	—	dB
		777... 787 MHz	33	47	—	dB
		787... 960 MHz	33	44	—	dB
		1427.9... 1462.9 MHz	32	41	—	dB
		1710... 1910 MHz	34	40	—	dB
		1910... 2025 MHz	33	39	—	dB
		2110... 2170 MHz	30	38	—	dB
		2300... 2500 MHz	30	38	—	dB
		2500... 2690 MHz	29	36	—	dB
		3400... 3800 MHz	—	27	—	dB
<b>VSWR</b>	VSWR					
@ ANT port		1559.052... 1563.144 MHz	—	1.2	2.0	
		1574.42... 1576.42 MHz	—	1.3	2.0	
		1597.55... 1605.89 MHz	—	1.4	2.0	
@ GNSS port		1559.052... 1563.144 MHz	—	1.3	2.1	
		1574.42... 1576.42 MHz	—	1.3	2.0	
		1597.55... 1605.89 MHz	—	1.3	2.0	

## 7 Characteristics ANT – CELL

Temperature range for specification	$T_{SPEC}$	= -30 °C ... +85 °C
ANT terminating impedance	$Z_{ANT}$	= 50 $\Omega$
GNSS terminating impedance	$Z_{GNSS}$	= 50 $\Omega$
CELL terminating impedance	$Z_{CELL}$	= 50 $\Omega$

Characteristics ANT – CELL			min. for $T_{SPEC}$	typ. @ +25 °C	max. for $T_{SPEC}$	
<b>Insertion loss</b>	$\alpha$					
		566... 626 MHz	—	2.1	3.2	dB
		699... 824 MHz	—	0.95	1.9	dB
		824... 960 MHz	—	0.65	1.5	dB
		1427.9... 1510.9 MHz	—	0.7	1.7	dB
		1710... 1850 MHz	—	1.2	1.8	dB
		1850... 2025 MHz	—	1.1	1.7	dB
		2110... 2170 MHz	—	1.2	1.9	dB
		2300... 2400 MHz	—	1.0	1.6	dB
		2400... 2690 MHz	—	0.8	1.5	dB
		3400... 3600 MHz	—	1.1	—	dB
		3600... 3800 MHz	—	1.3	—	dB
<b>Attenuation</b>	$\alpha$					
		1559.052... 1563.144 MHz	5	10	—	dB
		1574.42... 1576.42 MHz	11	19	—	dB
		1597.55... 1605.89 MHz	5	13	—	dB
<b>VSWR</b>	VSWR					
		@ ANT port				
		566... 626 MHz	—	1.6	2.3	
		699... 824 MHz	—	1.1	2.0	
		824... 960 MHz	—	1.1	2.0	
		1427.9... 1510.9 MHz	—	1.6	2.1	
		1710... 2025 MHz	—	1.3	2.0	
		2110... 2170 MHz	—	1.3	2.0	
		2300... 2400 MHz	—	1.3	2.0	
		2400... 2690 MHz	—	1.2	2.0	
		3400... 3600 MHz	—	1.7	—	
		3600... 3800 MHz	—	1.8	—	
		@ CELL port				
		566... 626 MHz	—	1.4	2.2	
		699... 824 MHz	—	1.2	2.0	
824... 960 MHz	—	1.1	2.0			
1427.9... 1510.9 MHz	—	1.6	2.1			
1710... 2025 MHz	—	1.5	2.1			
2110... 2170 MHz	—	1.4	2.0			
2300... 2400 MHz	—	1.4	2.0			
2400... 2690 MHz	—	1.3	2.0			

Characteristics ANT – CELL		min. for $T_{SPEC}$	typ. @ +25 °C	max. for $T_{SPEC}$
3400... 3600	MHz	—	1.7	—
3600... 3800	MHz	—	1.9	—

## 8 Characteristics GNSS – CELL

Temperature range for specification	$T_{SPEC}$	= -30 °C ... +85 °C
ANT terminating impedance	$Z_{ANT}$	= 50 $\Omega$
GNSS terminating impedance	$Z_{GNSS}$	= 50 $\Omega$
CELL terminating impedance	$Z_{CELL}$	= 50 $\Omega$

Characteristics GNSS – CELL			min. for $T_{SPEC}$	typ. @ +25 °C	max. for $T_{SPEC}$	
<b>Isolation</b>	$\alpha$	566... 777 MHz	34	48	—	dB
		777... 787 MHz	34	48	—	dB
		787... 960 MHz	34	45	—	dB
		1427.9... 1462.9 MHz	31	40	—	dB
		1710... 1990 MHz	36	44	—	dB
		2110... 2170 MHz	37	45	—	dB
		2400... 2690 MHz	32	40	—	dB
		3400... 3800 MHz	—	31	—	dB

## 9 Maximum ratings

Storage temperature	$T_{STG}^{1)} = -40\text{ °C} \dots +85\text{ °C}$	
DC voltage	$ V_{DC}  = 5.0\text{ V (max.)}^{2)}$	
ESD voltage		
	$V_{ESD}^{3)} = 50\text{ V (max.)}$	Machine model.
	$V_{ESD}^{4)} = 350\text{ V (max.)}$	Human body model.
	$V_{ESD}^{5)} = 600\text{ V (max.)}$	Charged device model.
Input power	$P_{IN}$	
@ CELL port: 566 ... 626 MHz	28 dBm	Continuous wave for 5000 h @ 55 °C.
@ CELL port: 699 ... 915 MHz	27 dBm	Continuous wave for 5000 h @ 55 °C.
@ CELL port: 824 ... 849 MHz	35 dBm	GSM signal duty cycle 1:8 for 5000 h @ 55 °C. Effective power in On-state.
@ CELL port: 880 ... 915 MHz	35 dBm	GSM signal duty cycle 1:8 for 5000 h @ 55 °C. Effective power in On-state.
@ CELL port: 1710 ... 1785 MHz	33 dBm	GSM signal duty cycle 1:8 for 5000 h @ 55 °C.
@ CELL port: 1710 ... 2690 MHz	27 dBm	Continuous wave for 5000 h @ 55 °C.
@ CELL port: 1850 ... 1910 MHz	33 dBm	GSM signal duty cycle 1:8 for 5000 h @ 55 °C. Effective power in On-state.

<sup>1)</sup> Not valid for packaging material. Storage temperature for packaging material is -25 °C to +40 °C.

<sup>2)</sup> 168h Damp Heat Steady State acc. to IEC60068-2-67 Cy.

<sup>3)</sup> According to JESD22-A115B (MM – Machine Model), 10 negative & 10 positive pulses.

<sup>4)</sup> According to JESD22-A114F (HBM – Human Body Model), 1 negative & 1 positive pulse.

<sup>5)</sup> According to JESD22-C101C (CDM – Field Induced Charged Device Model), 3 negative & 3 positive pulses.

10 Transmission coefficient ANT – GNSS

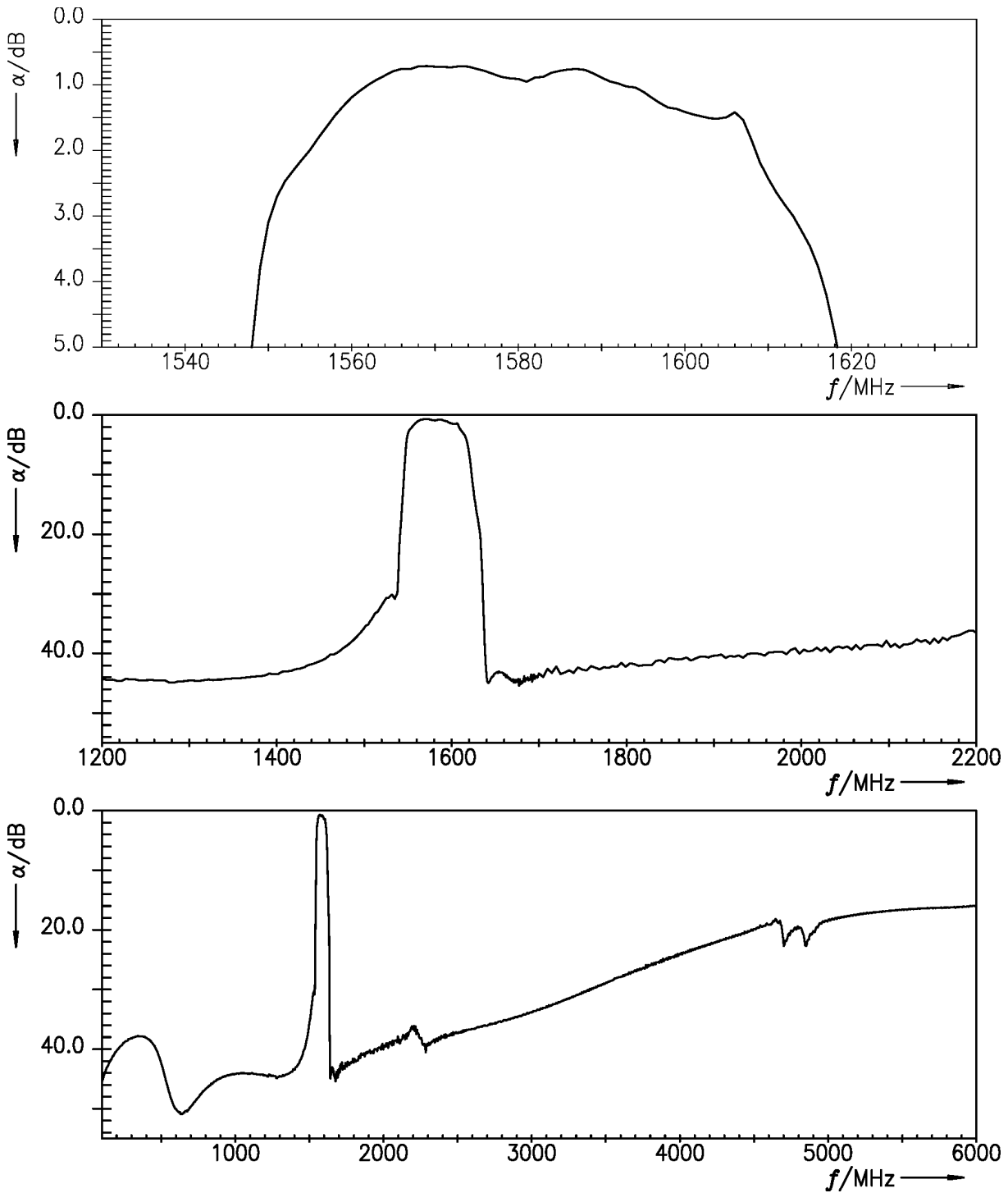

Figure 4: Attenuation ANT – GNSS.

11 Reflection coefficients ANT – GNSS

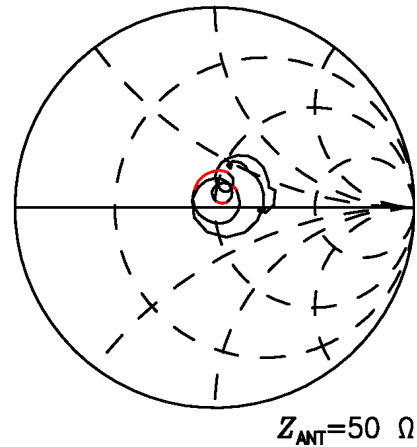
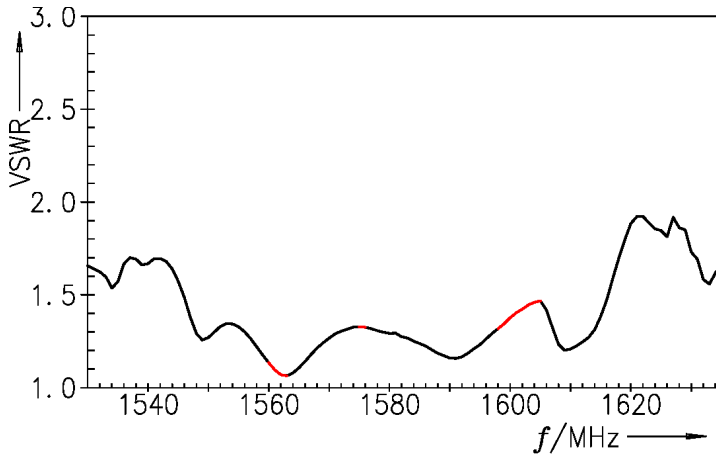

Figure 5: Reflection coefficient at ANT port.

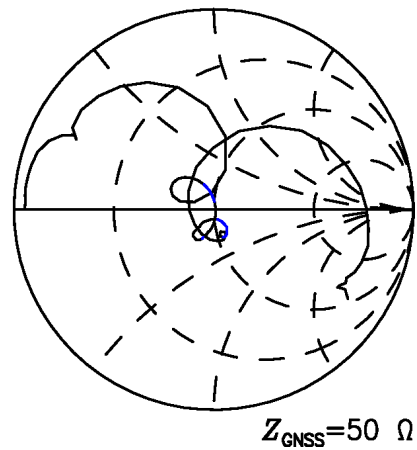
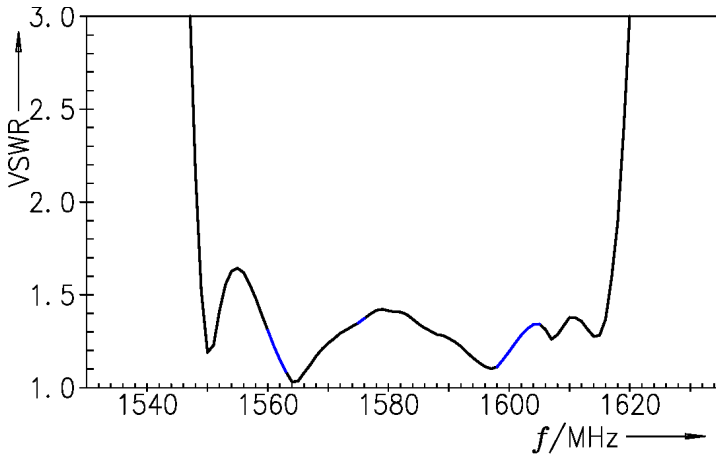

Figure 6: Reflection coefficient at GNSS port.

12 Transmission coefficient ANT – CELL

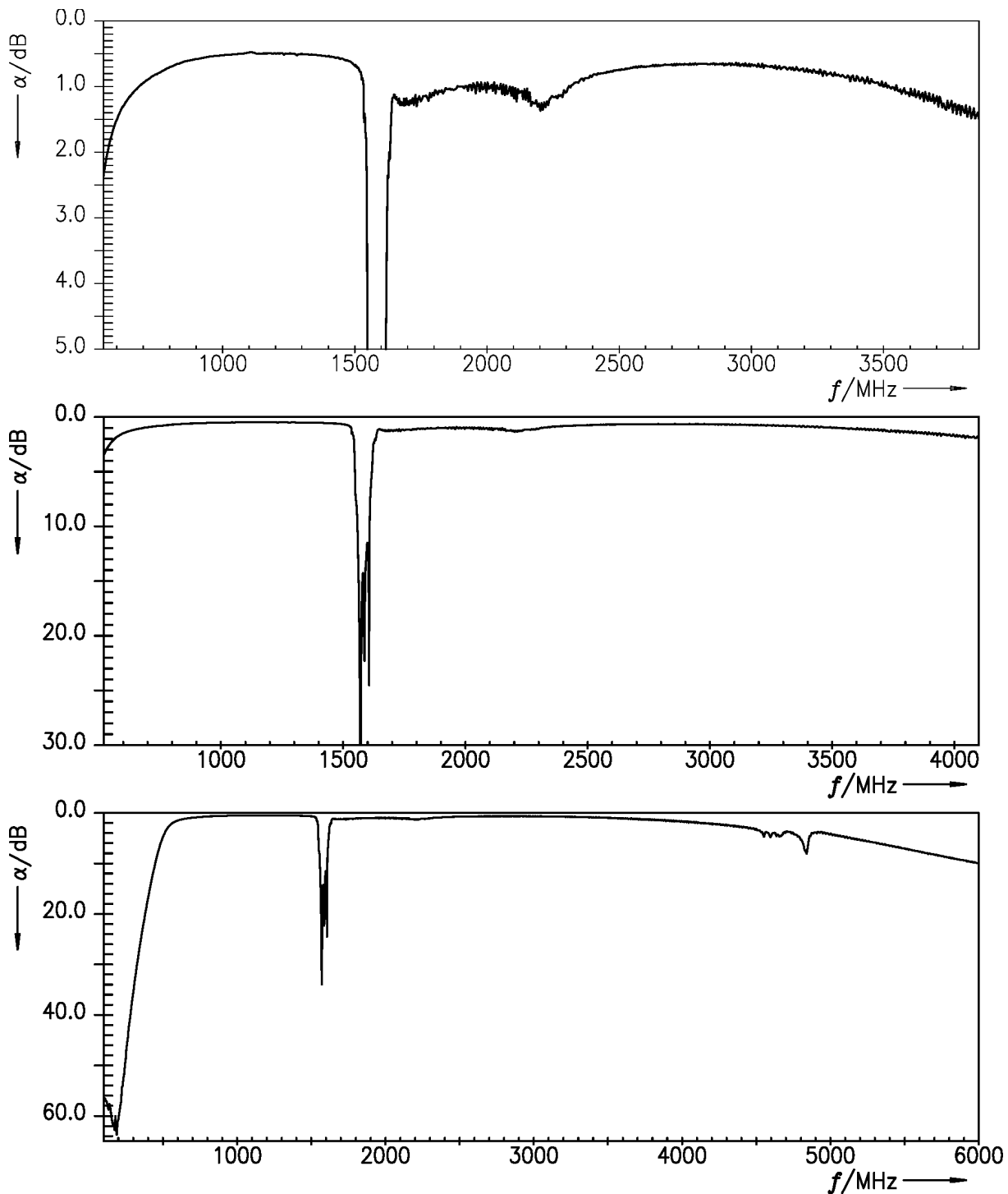

Figure 7: Attenuation ANT – CELL.



13 Reflection coefficients ANT – CELL

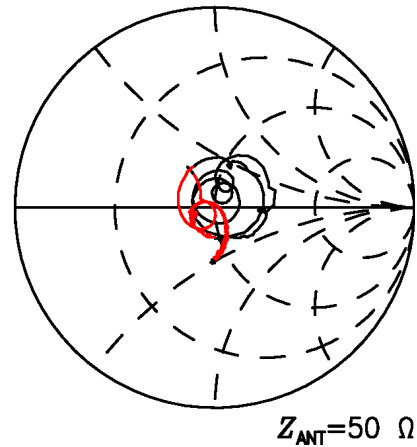
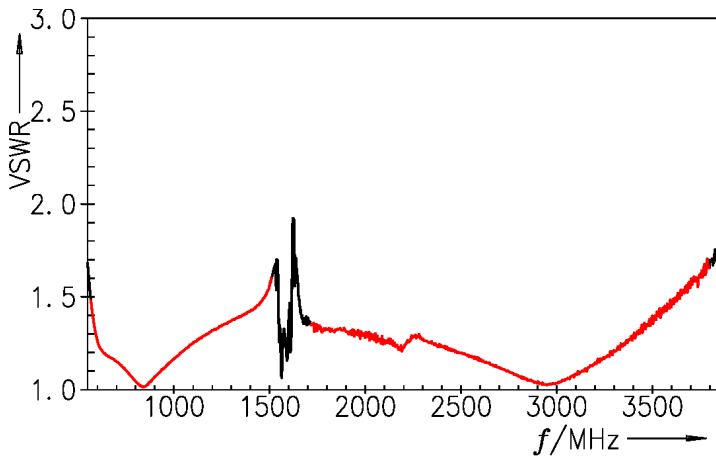

Figure 8: Reflection coefficient at ANT port.

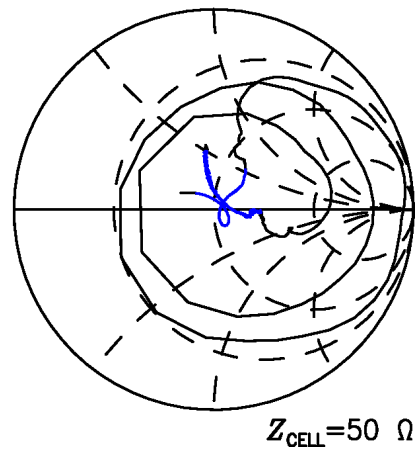
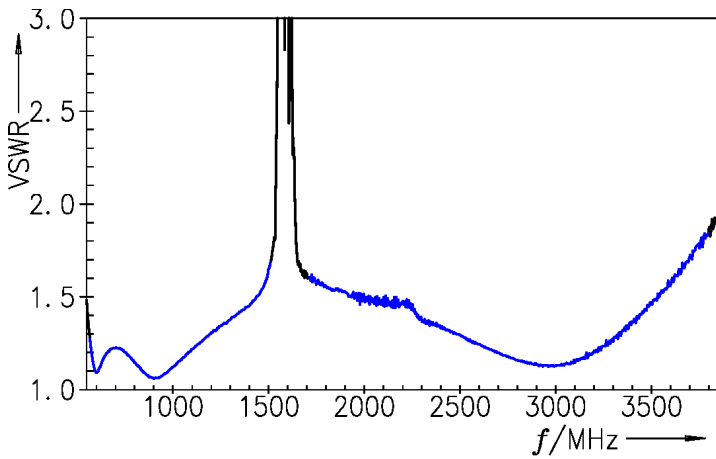

Figure 9: Reflection coefficient at CELL port.

14 Transmission coefficient GNSS – CELL

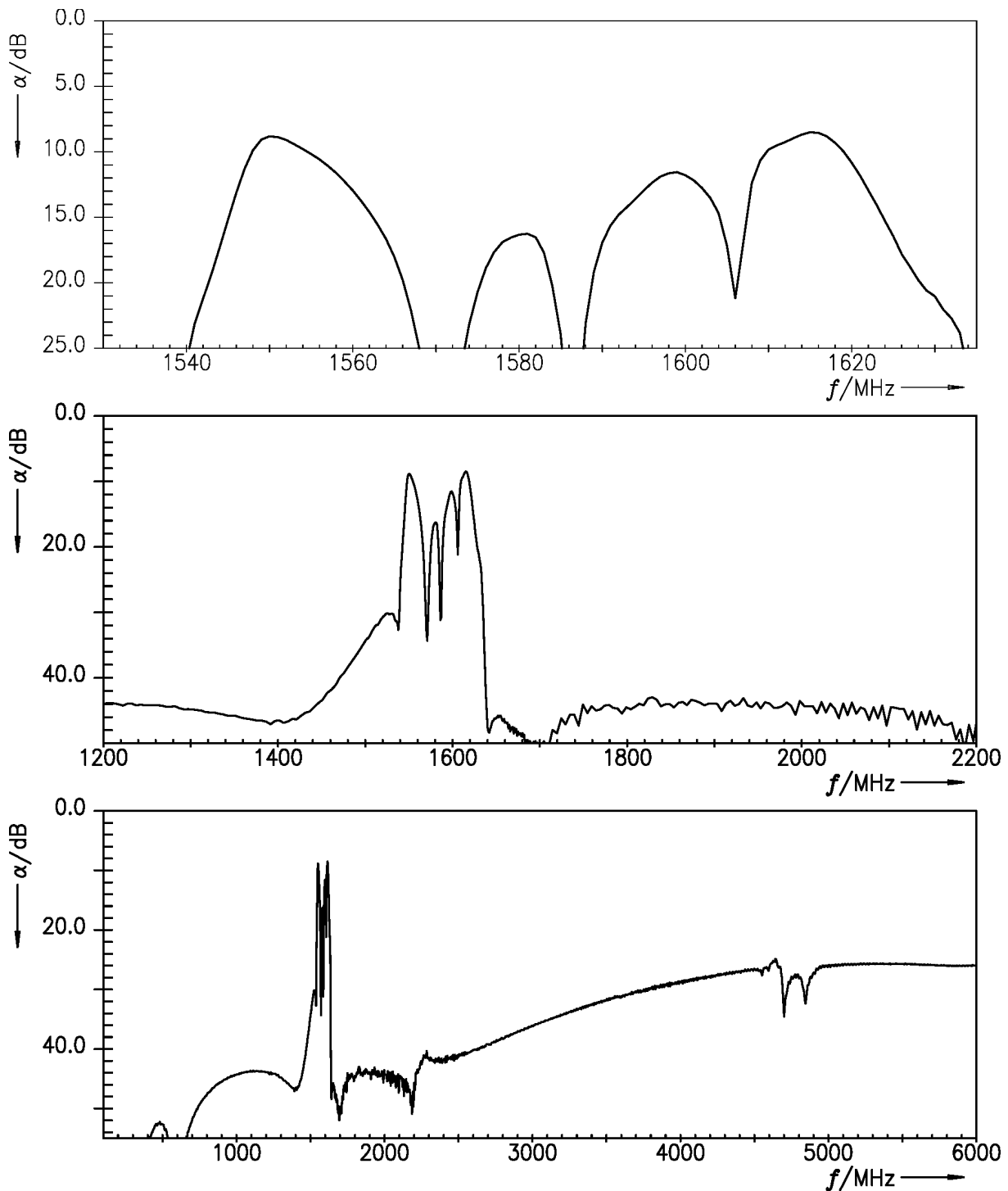
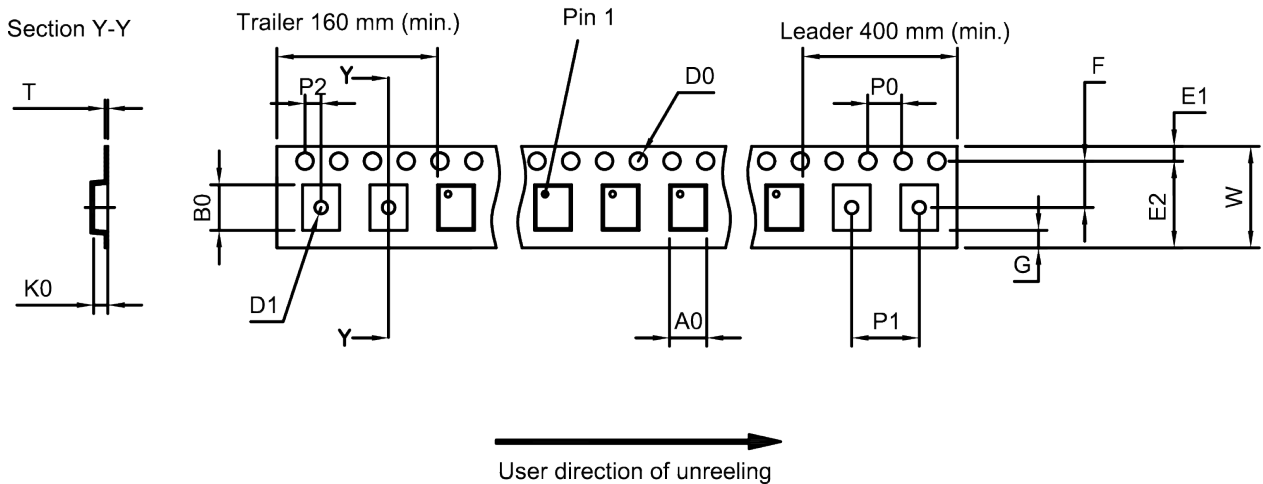

Figure 10: Cross-isolation GNSS – CELL.

## 15 Packing material

### 15.1 Tape



**Figure 11:** Drawing of tape (first-angle projection) is for illustration only and not to scale. Tape Dimensions in Table 1 are the valid dimensions for the tape.

A <sub>0</sub>	1.52±0.05 mm
B <sub>0</sub>	1.94±0.05 mm
D <sub>0</sub>	1.55±0.05 mm
D <sub>1</sub>	0.50±0.05 mm
E <sub>1</sub>	1.75±0.1 mm

E <sub>2</sub>	6.25 mm (min.)
F	3.5±0.05 mm
G	0.75 mm (min.)
K <sub>0</sub>	0.62±0.05 mm
P <sub>0</sub>	4.0±0.1 mm

P <sub>1</sub>	4.0±0.1 mm
P <sub>2</sub>	2.0±0.1 mm
T	0.25±0.03 mm
W	8.0+0.3/-0 mm

**Table 1:** Tape dimensions.

15.2 Reel with diameter of 180 mm

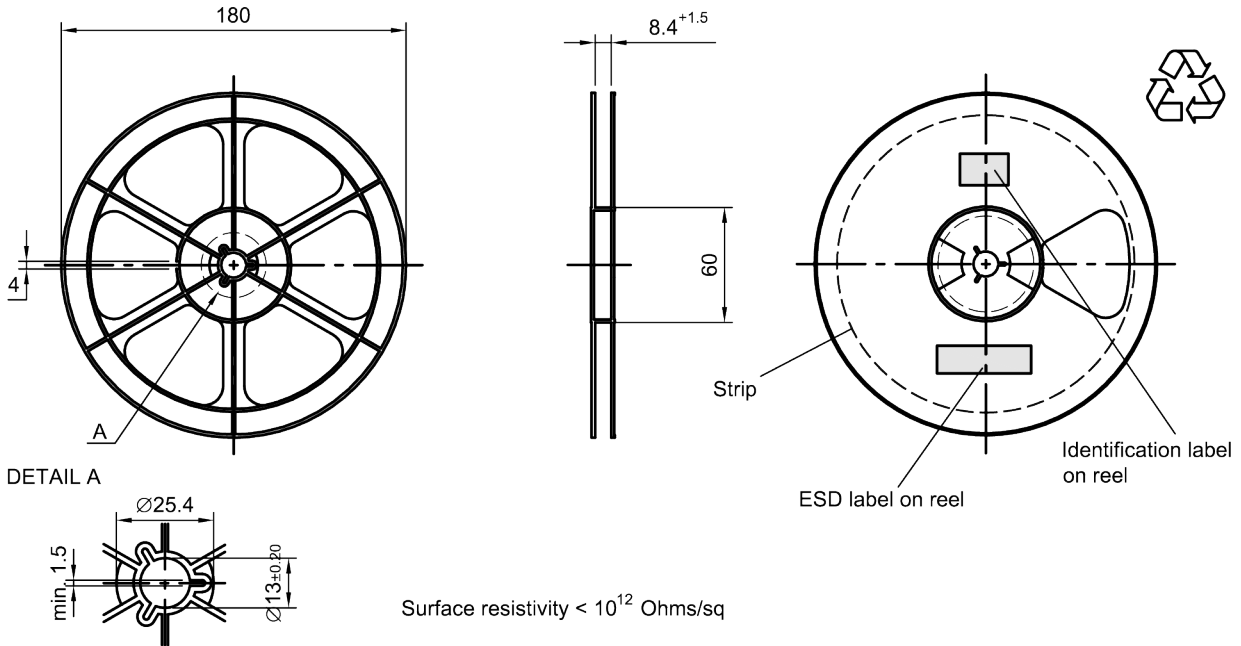

Figure 12: Drawing of reel (first-angle projection) with diameter of 180 mm.

Dimensions [mm]

X = 220+5

Y = 235+5

Sealing area 10±3

Printing on vacuumbag

Sealing area

Drypack in vacuumbag

Identification label on vacuumbag

Humidity indicator in vacuumbag

Vacuumbag



Figure 13: Drawing of moisture barrier bag (MBB) for reel with diameter of 180 mm.

Dimensions [mm]  
L = 188  
B = 188  
H = 30  
Tolerance ±5

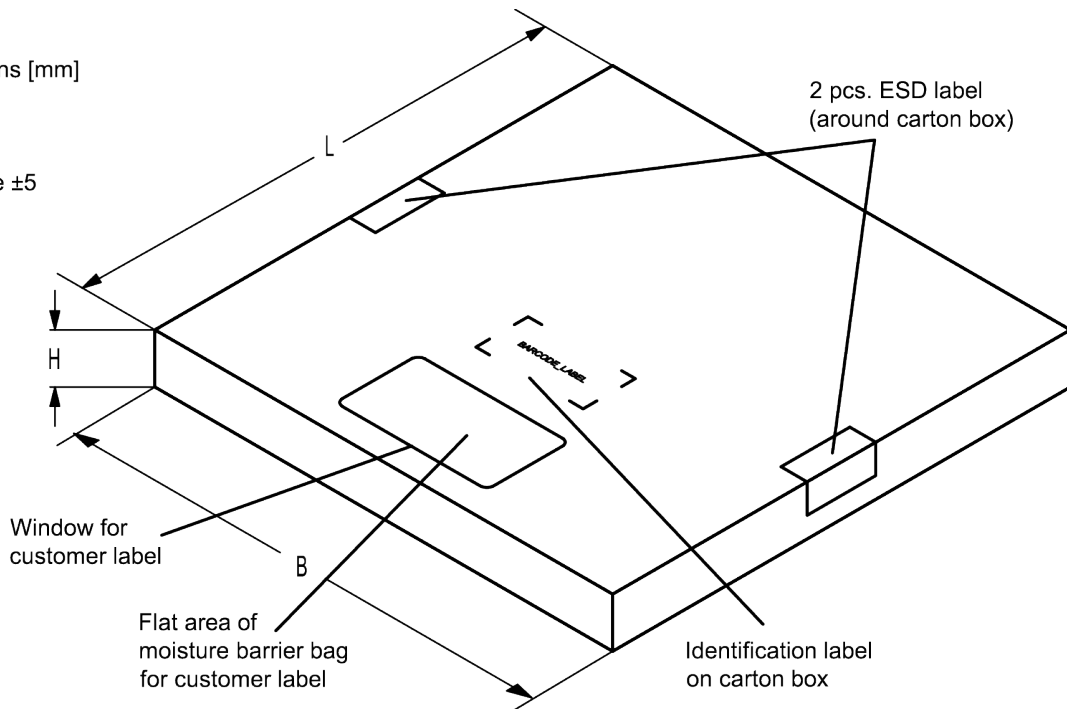

Figure 14: Drawing of folding box for reel with diameter of 180 mm.

15.3 Reel with diameter of 330 mm

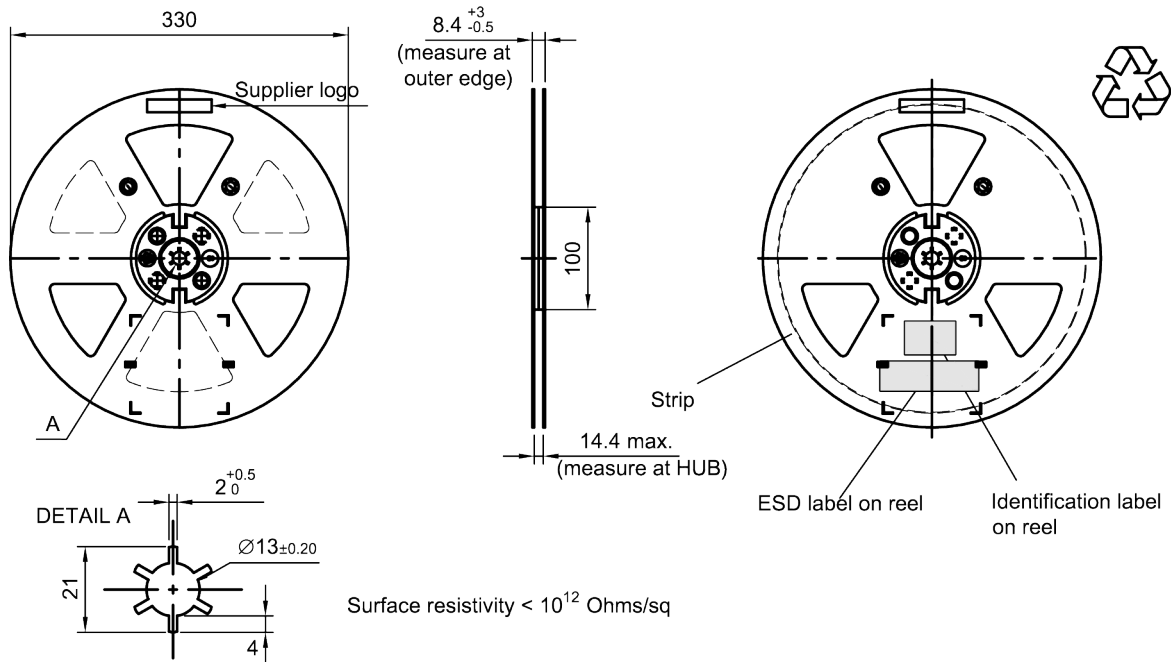

Figure 15: Drawing of reel (first-angle projection) with diameter of 330 mm.

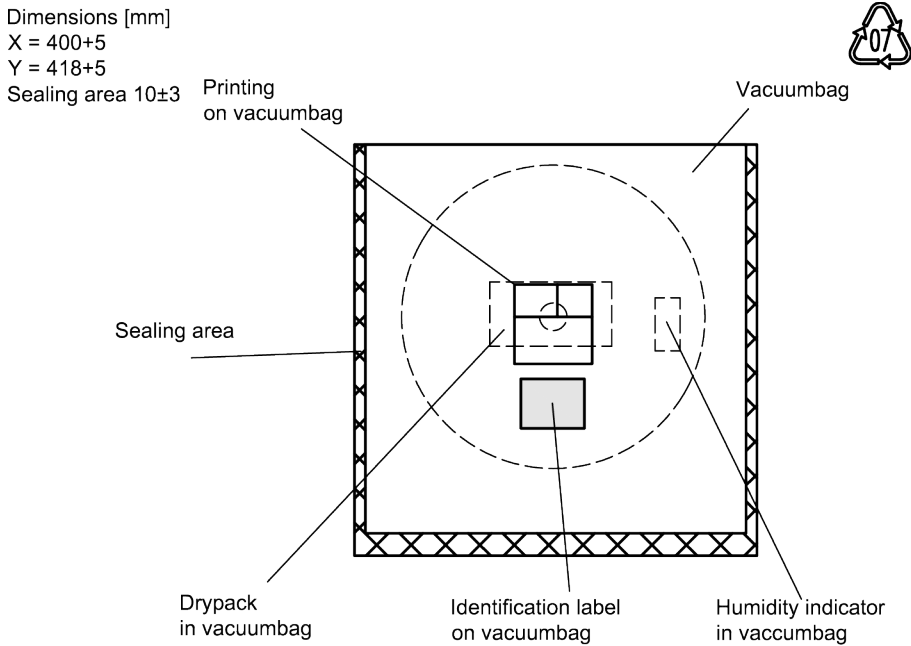

Figure 16: Drawing of moisture barrier bag (MBB) for reel with diameter of 330 mm.

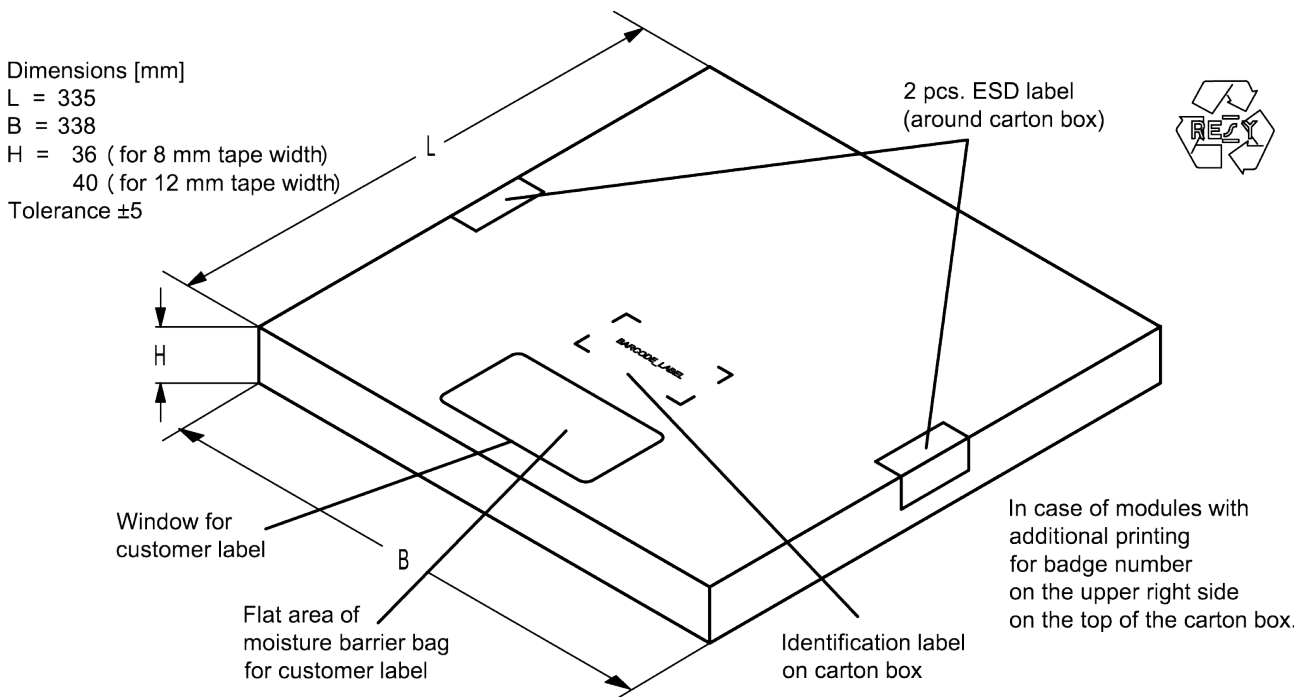

Figure 17: Drawing of folding box for reel with diameter of 330 mm.

**16 Marking**

Products are marked with product type number and lot number encoded according to Table 2:

■ Type number:

The 4 digit type number of the ordering code, e.g., B3xxxxB**1234**xxxx,  
is encoded by a special BASE32 code into a 3 digit marking.

Example of decoding type number marking on device in decimal code.  
**16J** => **1234**  
 $1 \times 32^2 + 6 \times 32^1 + 18 (=J) \times 32^0 =$  **1234**

The BASE32 code for product type B8666 is 8ET.

■ Lot number:

The last 5 digits of the lot number, e.g., **12345**,  
are encoded based on a special BASE47 code into a 3 digit marking.

Example of decoding lot number marking on device in decimal code.  
**5UY** => **12345**  
 $5 \times 47^2 + 27 (=U) \times 47^1 + 31 (=Y) \times 47^0 =$  **12345**

Adopted BASE32 code for type number			
Decimal value	Base32 code	Decimal value	Base32 code
0	0	16	G
1	1	17	H
2	2	18	J
3	3	19	K
4	4	20	M
5	5	21	N
6	6	22	P
7	7	23	Q
8	8	24	R
9	9	25	S
10	A	26	T
11	B	27	V
12	C	28	W
13	D	29	X
14	E	30	Y
15	F	31	Z

Adopted BASE47 code for lot number			
Decimal value	Base47 code	Decimal value	Base47 code
0	0	24	R
1	1	25	S
2	2	26	T
3	3	27	U
4	4	28	V
5	5	29	W
6	6	30	X
7	7	31	Y
8	8	32	Z
9	9	33	b
10	A	34	d
11	B	35	f
12	C	36	h
13	D	37	n
14	E	38	r
15	F	39	t
16	G	40	v
17	H	41	\
18	J	42	?
19	K	43	{
20	L	44	}
21	M	45	<
22	N	46	>
23	P		

**Table 2:** Lists for encoding and decoding of marking.

**17 Soldering profile**

The recommended soldering process is in accordance with IEC 60068-2-58 – 3<sup>rd</sup> edit and IPC/JEDEC J-STD-020B.

ramp rate	≤ 3 K/s
preheat	125 °C to 220 °C, 150 s to 210 s, 0.4 K/s to 1.0 K/s
T > 220 °C	30 s to 70 s
T > 230 °C	min. 10 s
T > 245 °C	max. 20 s
T ≥ 255 °C	–
peak temperature $T_{peak}$	250 °C +0/-5 °C
wetting temperature $T_{min}$	230 °C +5/-0 °C for 10 s ± 1 s
cooling rate	≤ 3 K/s
soldering temperature T	measured at solder pads

**Table 3:** Characteristics of recommended soldering profile for lead-free solder (Sn95.5Ag3.8Cu0.7).

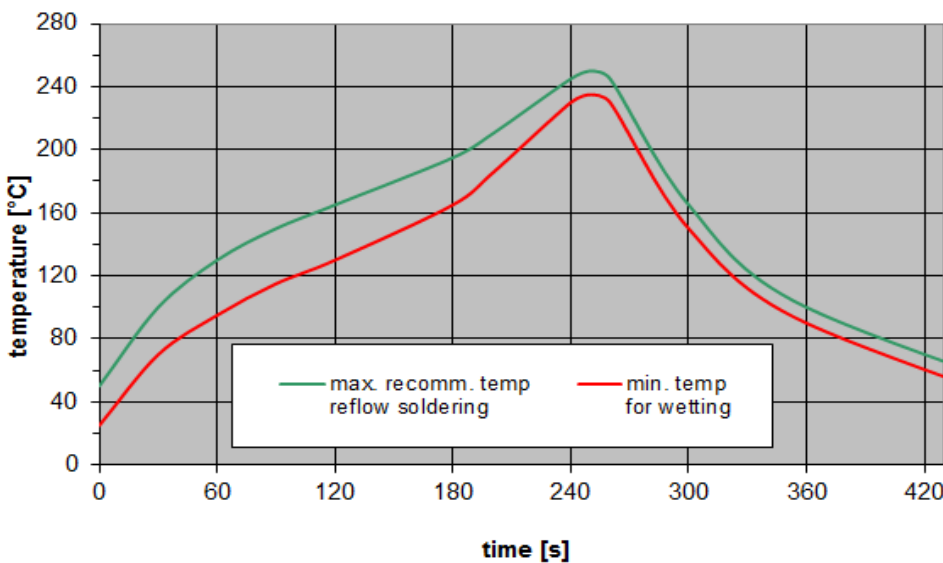

**Figure 18:** Recommended reflow profile for convection and infrared soldering – lead-free solder.



## 18 Annotations

### 18.1 Matching coils

See TDK inductor pdf-catalog <http://www.tdk.co.jp/tefe02/coil.htm#aname1> and Data Library for circuit simulation <http://www.tdk.co.jp/etvcl/index.htm>.

### 18.2 RoHS compatibility

ROHS-compatible means that products are compatible with the requirements according to Art. 4 (substance restrictions) of Directive 2011/65/EU of the European Parliament and of the Council of June 8th, 2011, on the restriction of the use of certain hazardous substances in electrical and electronic equipment ("Directive") with due regard to the application of exemptions as per Annex III of the Directive in certain cases.

### 18.3 Scattering parameters (S-parameters)

The pin/port assignment is available in the headers of the S-parameter files. Please contact your local RF360 sales office.

### 18.4 Ordering codes and packing units

Ordering code	Packing unit
B39162B8666L210	15000 pcs
B39162B8666L210S 5	5000 pcs

**Table 4:** Ordering codes and packing units.

## 19 Cautions and warnings

### 19.1 Display of ordering codes for RF360 products

The ordering code for one and the same product can be represented differently in data sheets, data books, other publications and the website of RF360, or in order-related documents such as shipping notes, order confirmations and product labels. The varying representations of the ordering codes are due to different processes employed and do not affect the specifications of the respective products. Detailed information can be found on the Internet under [www.rf360jv.com/orderingcodes](http://www.rf360jv.com/orderingcodes).

### 19.2 Material information

Due to technical requirements components may contain dangerous substances. For information on the type in question please also contact one of our sales offices.

For information on recycling of tapes and reels please contact one of our sales offices.

### 19.3 Moldability

Before using in overmolding environment, please contact your local RF360 sales office.

### 19.4 Package information

#### Landing area

The printed circuit board (PCB) land pattern (landing area) shown is based on RF360 internal development and empirical data and illustrated for example purposes, only. As customers' SMD assembly processes may have a plenty of variants and influence factors which are not under control or knowledge of RF360, additional careful process development on customer side is necessary and strongly recommended in order to achieve best soldering results tailored to the particular customer needs.

#### Dimensions

Unless otherwise specified all dimensions are understood using unit millimeter (mm).

#### Projection method

Unless otherwise specified first-angle projection is applied.

## 20 Important notes

The following applies to all products named in this publication:

1. Some parts of this publication contain **statements about the suitability of our products for certain areas of application**. These statements are based on our knowledge of typical requirements that are often placed on our products in the areas of application concerned. We nevertheless expressly point out **that such statements cannot be regarded as binding statements about the suitability of our products for a particular customer application**. As a rule, RF360 Europe GmbH and its affiliates are either unfamiliar with individual customer applications or less familiar with them than the customers themselves. For these reasons, it is always ultimately incumbent on the customer to check and decide whether an RF360 product with the properties described in the product specification is suitable for use in a particular customer application.
2. We also point out that **in individual cases, a malfunction of electronic components or failure before the end of their usual service life cannot be completely ruled out in the current state of the art, even if they are operated as specified**. In customer applications requiring a very high level of operational safety and especially in customer applications in which the malfunction or failure of an electronic component could endanger human life or health (e.g. in accident prevention or life-saving systems), it must therefore be ensured by means of suitable design of the customer application or other action taken by the customer (e.g. installation of protective circuitry or redundancy) that no injury or damage is sustained by third parties in the event of malfunction or failure of an electronic component.
3. **The warnings, cautions and product-specific notes must be observed.**
4. In order to satisfy certain technical requirements, **some of the products described in this publication may contain substances subject to restrictions in certain jurisdictions (e.g. because they are classed as hazardous)**. Useful information on this will be found in our Material Data Sheets on the Internet ([www.rf360jv.com/material](http://www.rf360jv.com/material)). Should you have any more detailed questions, please contact our sales offices.
5. We constantly strive to improve our products. Consequently, **the products described in this publication may change from time to time**. The same is true of the corresponding product specifications. Please check therefore to what extent product descriptions and specifications contained in this publication are still applicable before or when you place an order. We also **reserve the right to discontinue production and delivery of products**. Consequently, we cannot guarantee that all products named in this publication will always be available.  
The aforementioned does not apply in the case of individual agreements deviating from the foregoing for customer-specific products.

# Mouser Electronics

Authorized Distributor

Click to View Pricing, Inventory, Delivery & Lifecycle Information:

[Qualcomm RF360:](#)

[B39162B8666L210](#)

Компания «Life Electronics» занимается поставками электронных компонентов импортного и отечественного производства от производителей и со складов крупных дистрибьюторов Европы, Америки и Азии.

С конца 2013 года компания активно расширяет линейку поставок компонентов по направлению коаксиальный кабель, кварцевые генераторы и конденсаторы (керамические, пленочные, электролитические), за счёт заключения дистрибьюторских договоров

Мы предлагаем:

- Конкуренспособные цены и скидки постоянным клиентам.
- Специальные условия для постоянных клиентов.
- Подбор аналогов.
- Поставку компонентов в любых объемах, удовлетворяющих вашим потребностям.
- Приемлемые сроки поставки, возможна ускоренная поставка.
- Доставку товара в любую точку России и стран СНГ.
- Комплексную поставку.
- Работу по проектам и поставку образцов.
- Формирование склада под заказчика.
- Сертификаты соответствия на поставляемую продукцию (по желанию клиента).
- Тестирование поставляемой продукции.
- Поставку компонентов, требующих военную и космическую приемку.
- Входной контроль качества.
- Наличие сертификата ISO.

В составе нашей компании организован Конструкторский отдел, призванный помогать разработчикам, и инженерам.

Конструкторский отдел помогает осуществить:

- Регистрацию проекта у производителя компонентов.
- Техническую поддержку проекта.
- Защиту от снятия компонента с производства.
- Оценку стоимости проекта по компонентам.
- Изготовление тестовой платы монтаж и пусконаладочные работы.



Тел: +7 (812) 336 43 04 (многоканальный)  
Email: org@lifeelectronics.ru