

LOC	DIST	REVISIONS					
GP	00	P	LTN	DESCRIPTION	DATE	DWN	APVD
		B		REVISED PER ECR-18-002882	27FEB2018	IT	SH

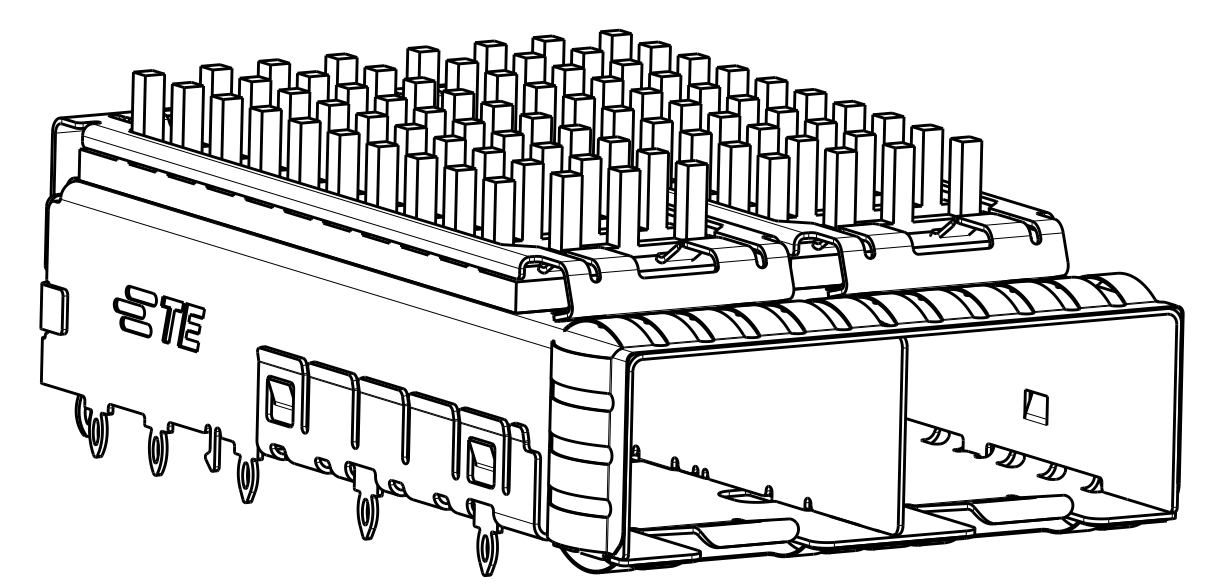

2198230-1, 2, 3, 4
 FINISHED ASSEMBLY WITH
 PIN TYPE HEAT SINK

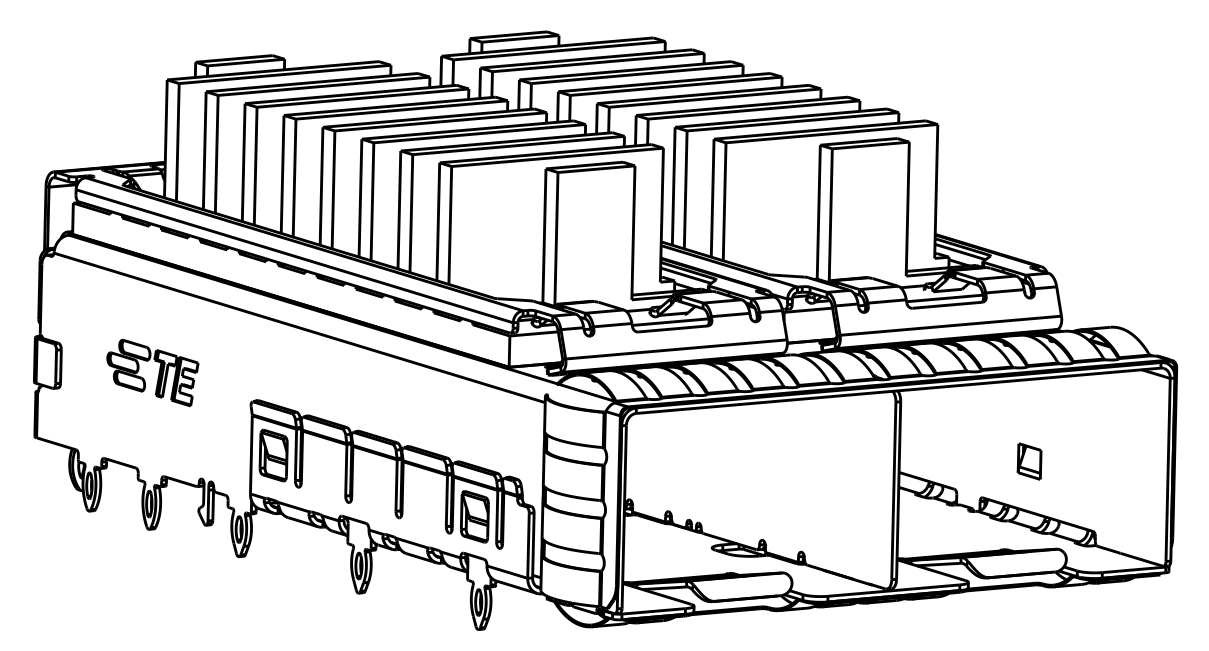

2198230-5, 6, 7, 8
 FINISHED ASSEMBLY WITH
 FIN TYPE HEAT SINK

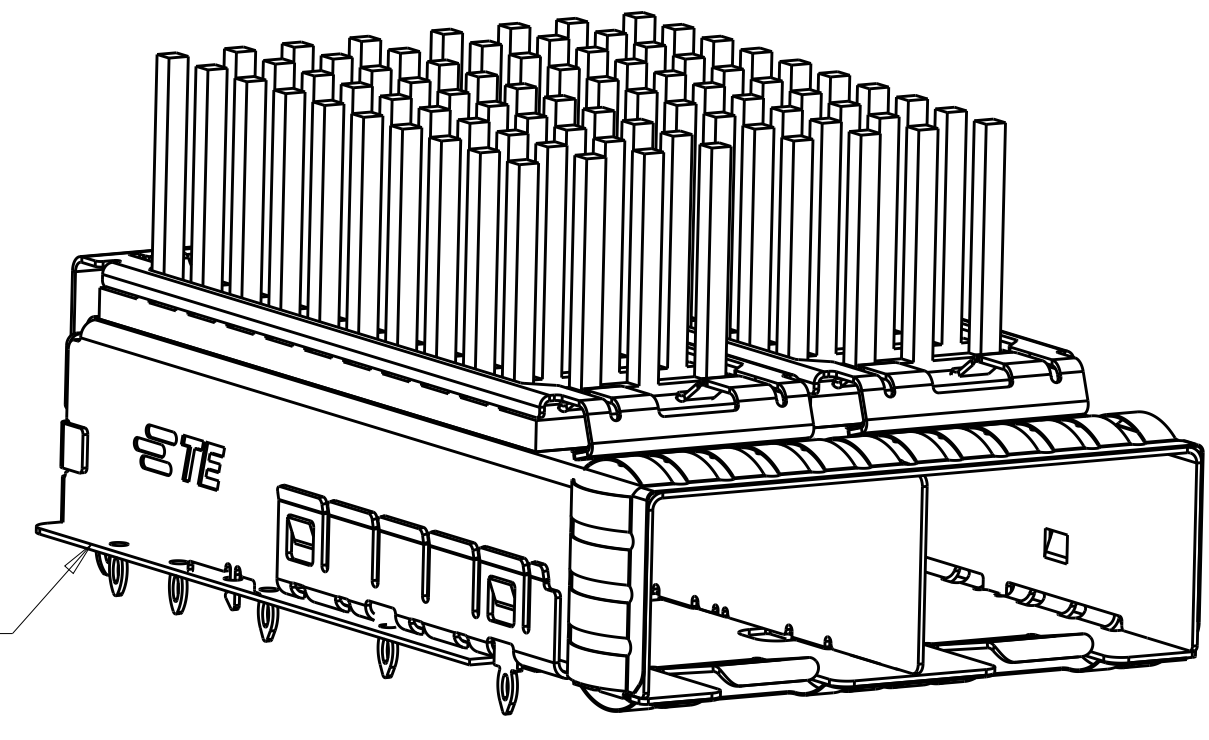

PCB GASKET

1-2198230-4
 FINISHED ASSEMBLY WITH
 PIN TYPE HEAT SINK, WITH BELLY GASKET

△ MATERIAL:
 CAGE ASSEMBLY:
 0.25mm THICK NICKEL SILVER ALLOY
 EMI SPRINGS: COPPER ALLOY
 HEAT SINK: ALUMINUM
 HEAT SINK CLIP: STAINLESS STEEL.

△ FINISH:
 HEAT SINK: ELECTROLESS NICKEL
 HEAT SINK CLIP: PASSIVATE.
 EMI SPRINGS: 0.8µm MIN MATTE TIN OVER
 0.8µm MIN NICKEL, NON-PLATED EDGES PERMISSIBLE.

△ DATUM AND BASIC DIMENSIONS ESTABLISHED BY CUSTOMER.
 △ PADS AND VIAS CHASSIS GROUND.

5. MATES WITH SFP MSA COMPLIANT RECIEVERS.
 6. INTERPRETATION OF DATUM REFERENCE FRAME IN ACCORDANCE WITH SECT 4.4.1.1 OR ASME Y14.5M-1994.

△ MINIMUM PC BOARD THICKNESS:
 SINGLE SIDED: 1.5mm
 DOUBLE SIDED: 2.25mm

△ HOLE PATTERN REPEATS FOR EACH PORT, SPACING BETWEEN PORTS IS 14.25mm.

△ REFERENCE APPLICATION SPEC. 114-13120, HOLE A, FOR RECOMMENDED DRILL HOLE DIAMETER AND PLATING THICKNESS.

△ REFERENCE APPLICATION SPEC. 114-13120, HOLE B, FOR RECOMMENDED DRILL HOLE DIAMETER AND PLATING THICKNESS.

11. CERTAIN MATING TRANCEIVERS MAY REQUIRE ADDITIONAL PCB THICKNESS THAT WOULD NEED TO BE DETERMINED BY THE CUSTOMER.
 12. PRODUCT COMPLIES WITH SPECIFICATION SFF-8433 IMPROVED PLUGGABLE FORM FACTOR FOR SFP+ GANGED CAGES.

△ DIMENSION APPLIES PRIOR TO INSERTION OF SFP MODULE.
 △ WITH BELLY GASKET: RF ABSORBER

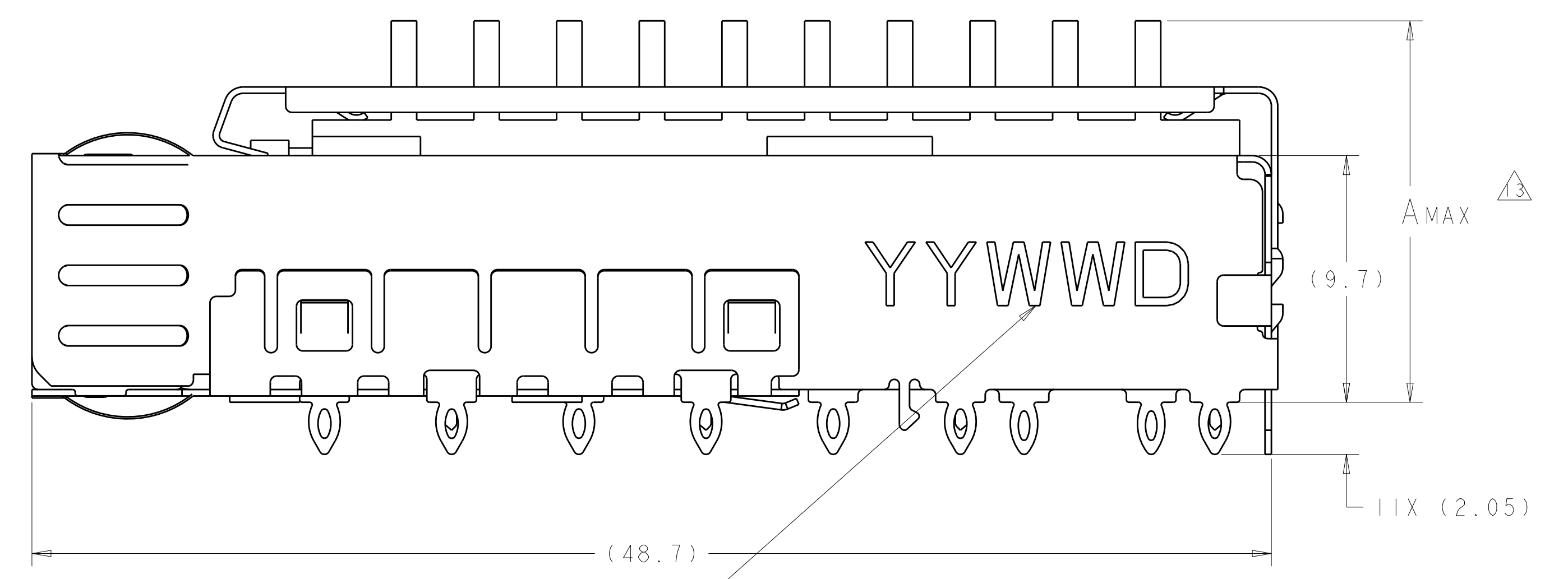
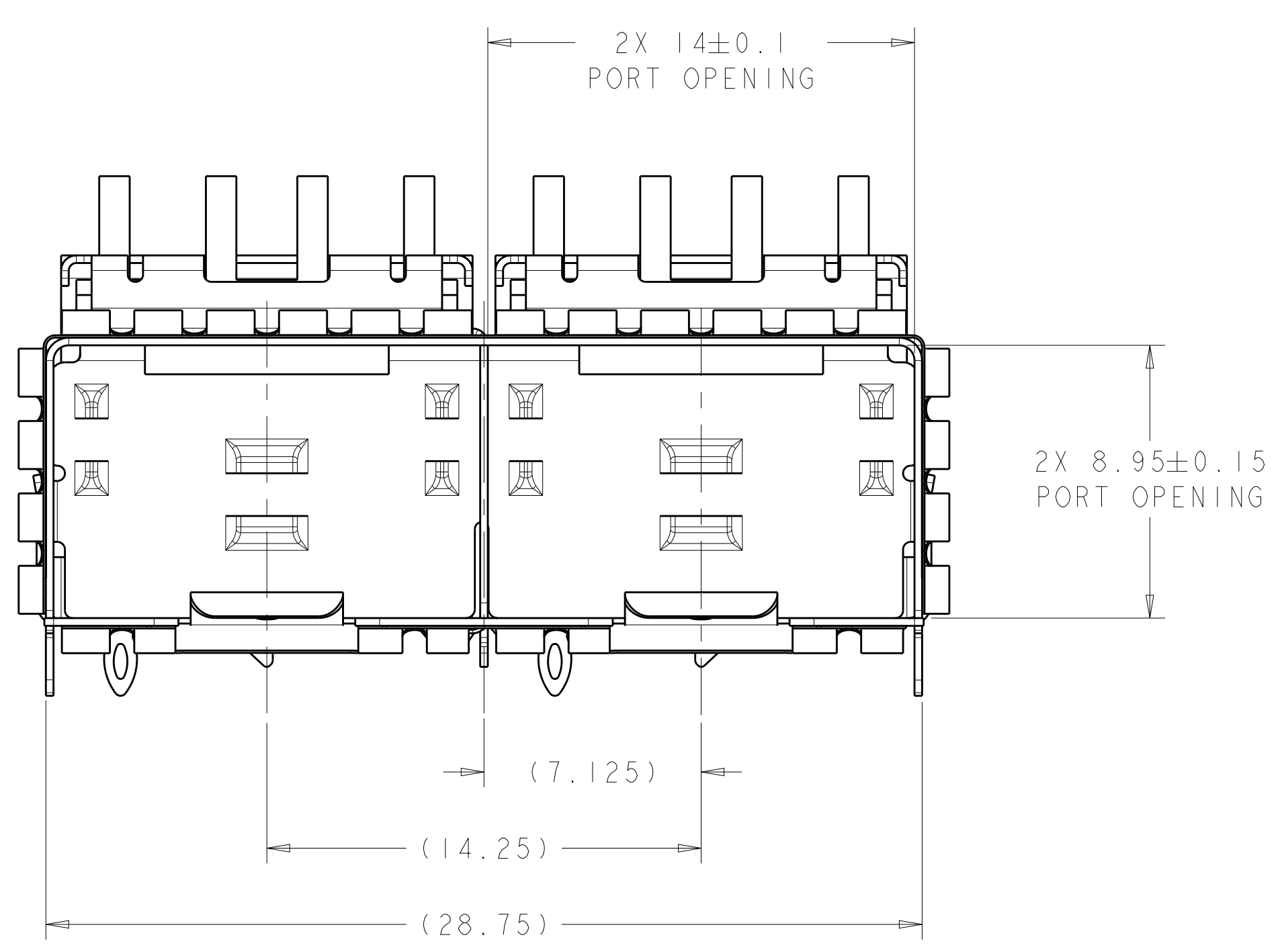

APPROXIMATE LOCATION OF DATE CODE

FIN TYPE	22.5	NETWORKING, TALL	2198230-8
FIN TYPE	18.1	NETWORKING, SHORT	2198230-7
FIN TYPE	15.5	SAN	2198230-6
FIN TYPE	13.2	PCI	2198230-5
PIN TYPE	22.5	NETWORKING, TALL	1-2198230-4
PIN TYPE	22.5	NETWORKING, TALL	2198230-4
PIN TYPE	18.1	NETWORKING, SHORT	2198230-3
PIN TYPE	15.5	SAN	2198230-2
PIN TYPE	13.2	PCI	2198230-1
HEAT SINK	A	DESCRIPTION	PART NUMBER

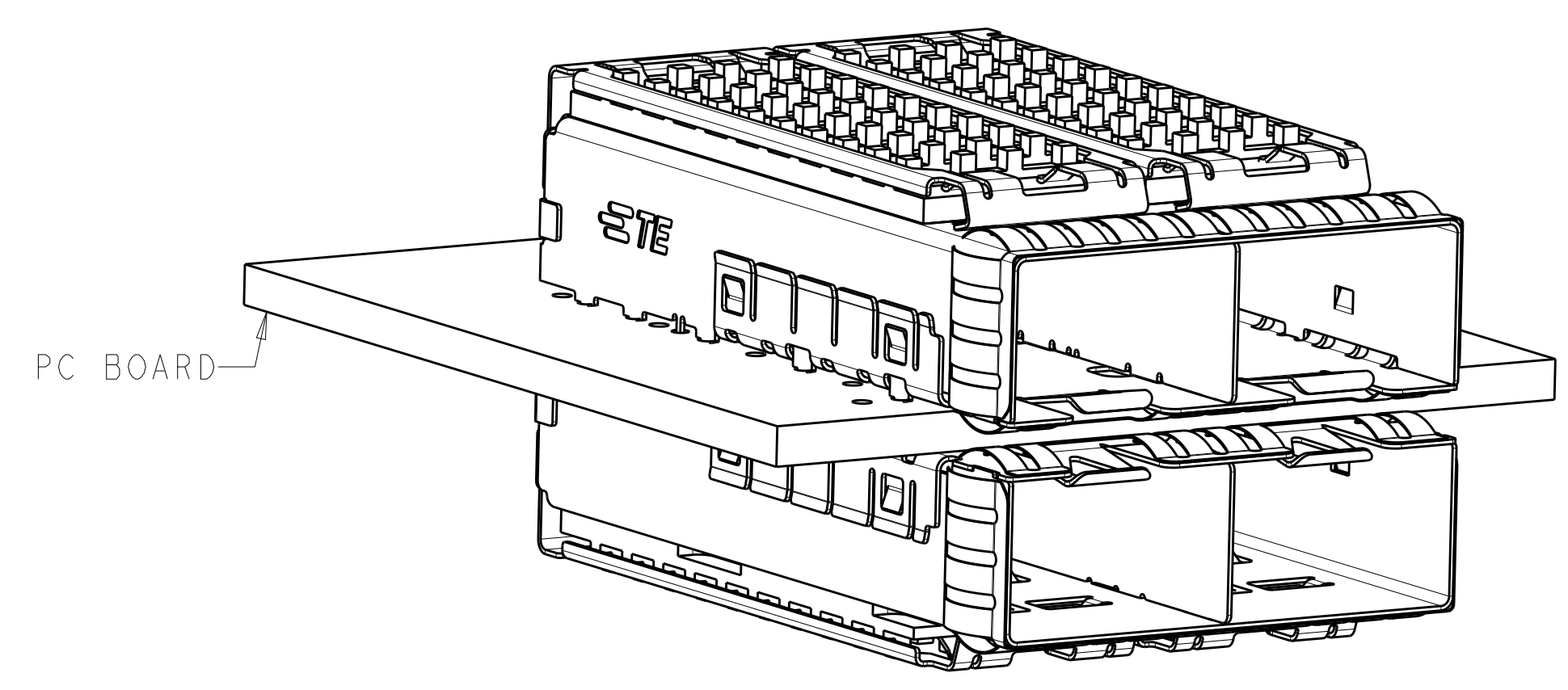

PC BOARD

2198230-1
 MOUNTED BELLY TO BELLY
 SCALE 3:1

THIS DRAWING IS A CONTROLLED DOCUMENT. DWN: C. VALENTINE 06OCT2011
 CHK: M. SCHMITT 06OCT2011
 APVD: M. SCHMITT 06OCT2011

STE TE Connectivity

NAME: SFP+ ENHANCED 1X2 CAGE ASSEMBLY, PRESS-FIT, EMI SPRINGS, HEAT SINK

PRODUCT SPEC: 108-2364
 APPLICATION SPEC: 114-13120

SIZE: A1
 CAGE CODE: 00779
 DRAWING NO: C=2198230

RESTRICTED TO: -

Customer Drawing SCALE 2:1 SHEET 1 OF 4 REV B

LOC		DIST		REVISIONS			
GP	00	P	LTN	DESCRIPTION	DATE	DMN	APVD
		-	-	SEE SHEET 1	-	-	-

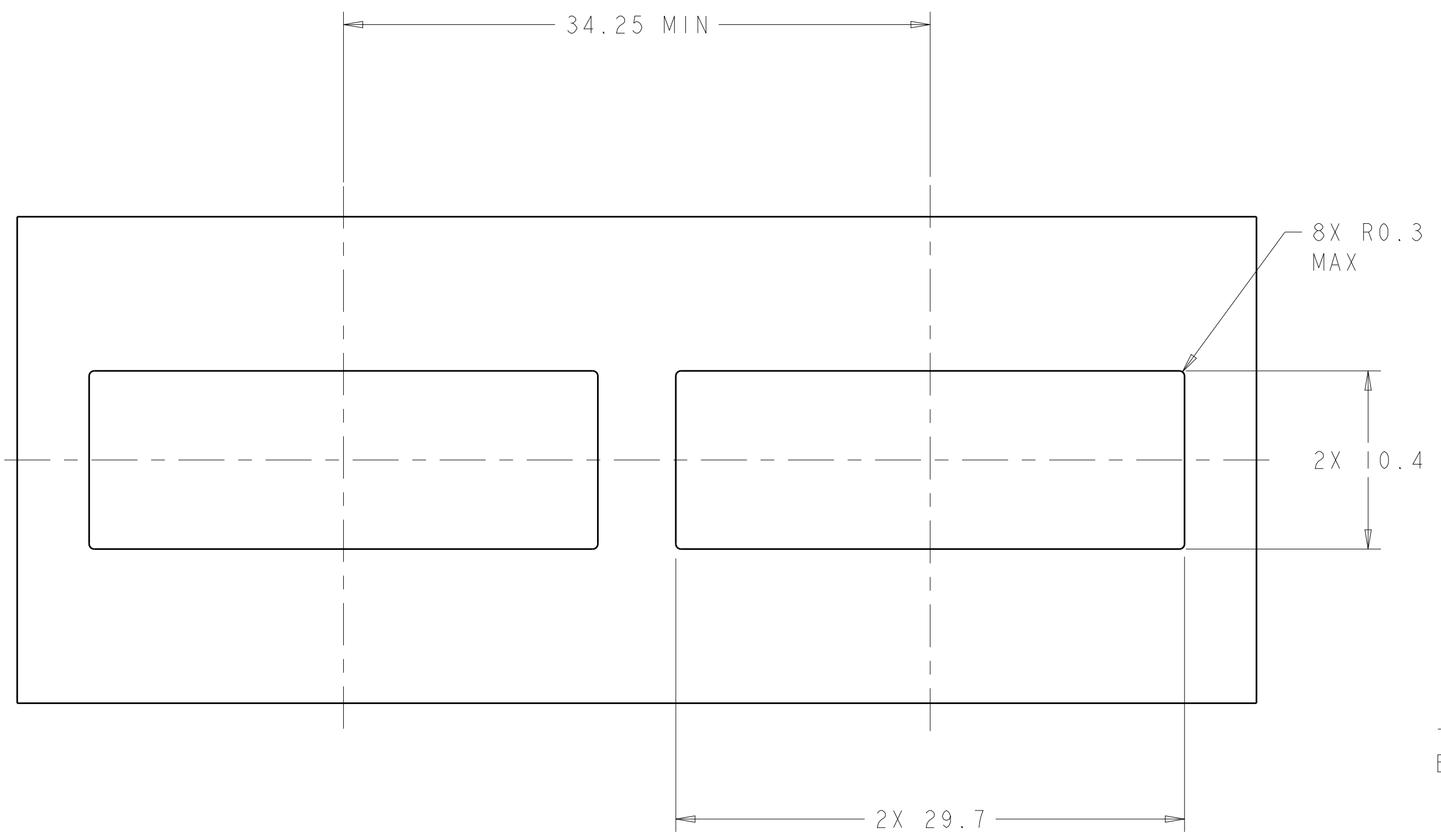

RECOMMENDED BEZEL CUT-OUT
 SINGLE SIDED APPLICATIONS
 SCALE 4:1

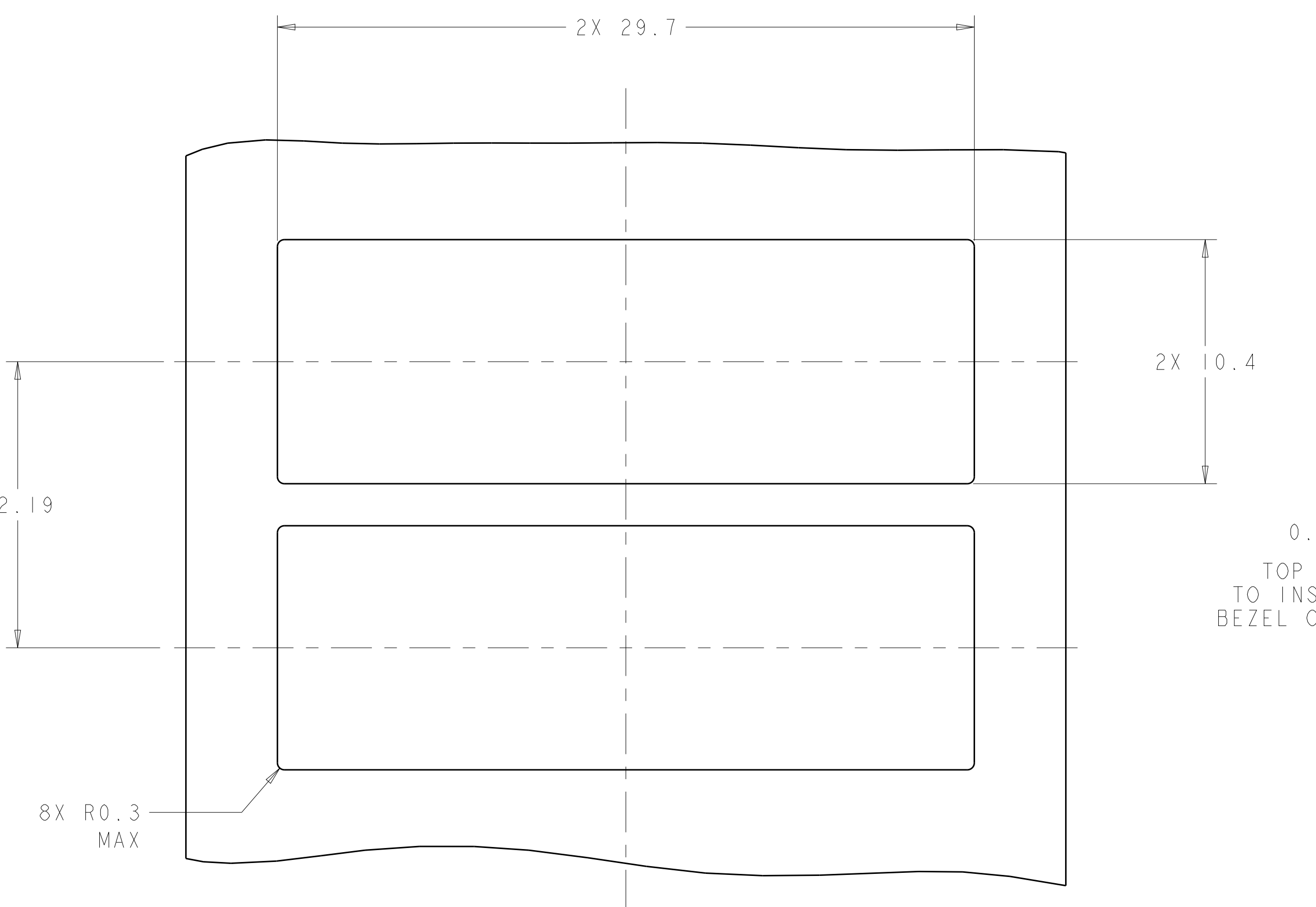

RECOMMENDED BEZEL CUT-OUT
 BELLY TO BELLY APPLICATIONS

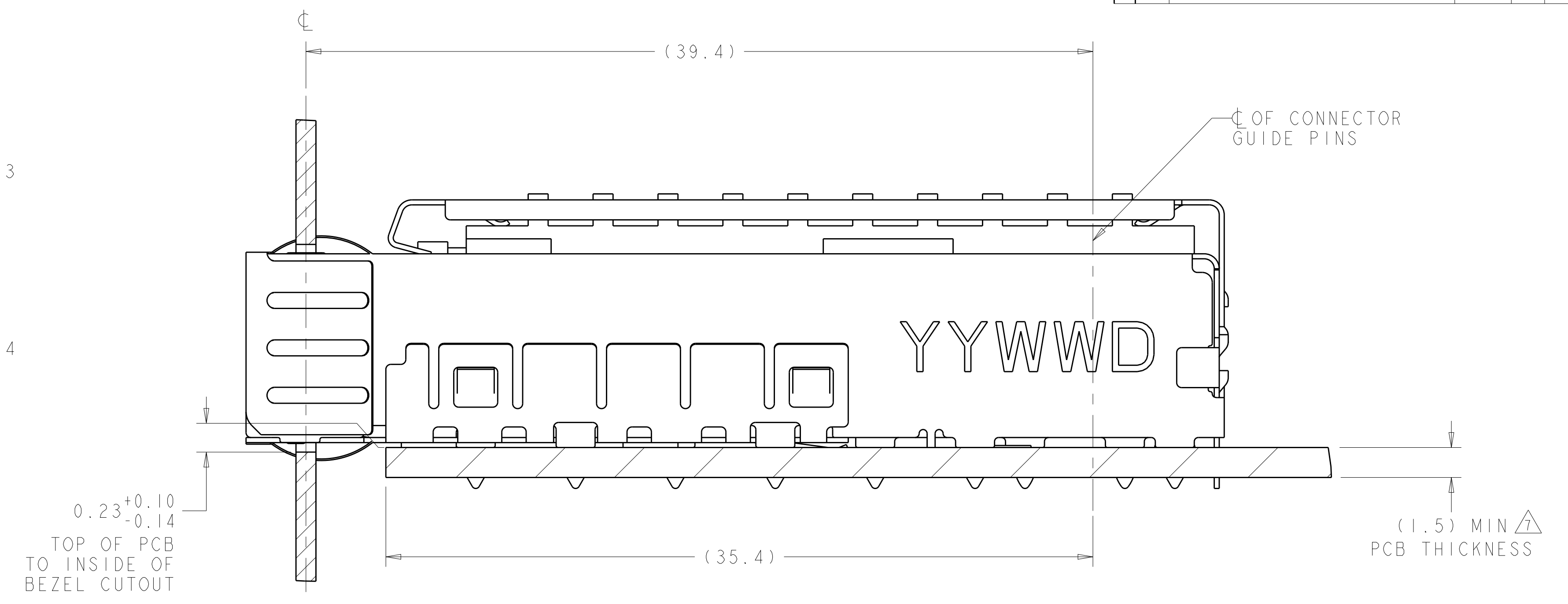

2198230-1
 MOUNTED ON PC BOARD
 SHOWN THRU RECOMMENDED BEZEL

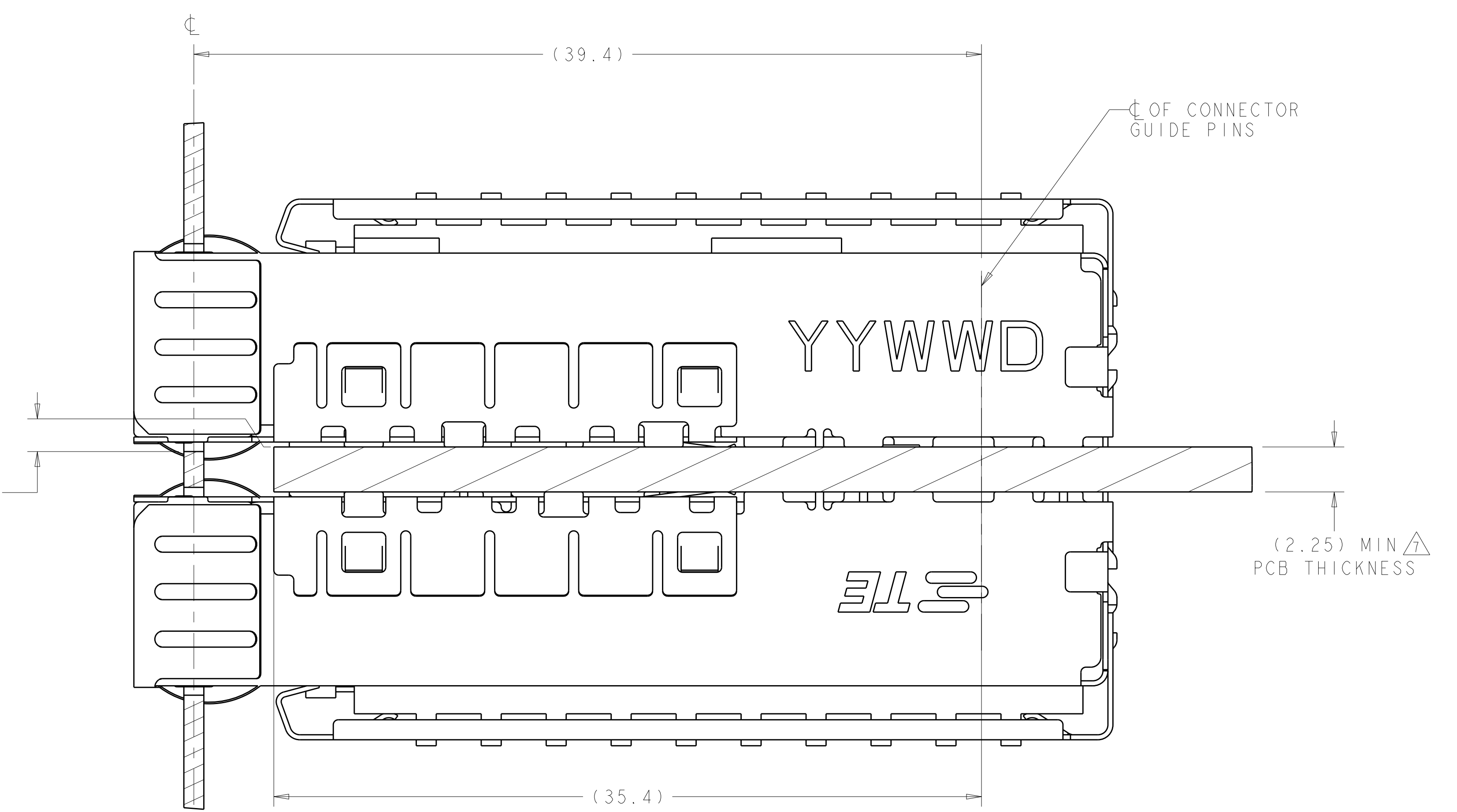

2198230-1
 MOUNTED BELLY TO BELLY ON PC BOARD
 SHOWN THRU RECOMMENDED BEZEL

THIS DRAWING IS A CONTROLLED DOCUMENT.		DMN C. VALENTINE 06OCT2011	TE Connectivity NAME SFP+ ENHANCED 1X2 CAGE ASSEMBLY, PRESS-FIT, EMI SPRINGS, HEAT SINK
DIMENSIONS: mm		CHK M. SCHMITT 06OCT2011	
TOLERANCES UNLESS OTHERWISE SPECIFIED:		APVD M. SCHMITT 06OCT2011	SIZE CAGE CODE DRAWING NO
0 PLC ±0.13	1 PLC ±0.1	PRODUCT SPEC	RESTRICTED TO
2 PLC ±0.08	3 PLC ±0.05	108-2364	A100779
4 PLC ±0.05	ANGLES ±0.5	APPLICATION SPEC	SCALE 6:1 SHEET 2 OF 4 REV B
MATERIAL	FINISH	114-13120	Customer Drawing
		WEIGHT	

LOC	DIST	REVISIONS			
GP	00	REV	DATE	BY	APPV
		1	SEE SHEET 1		

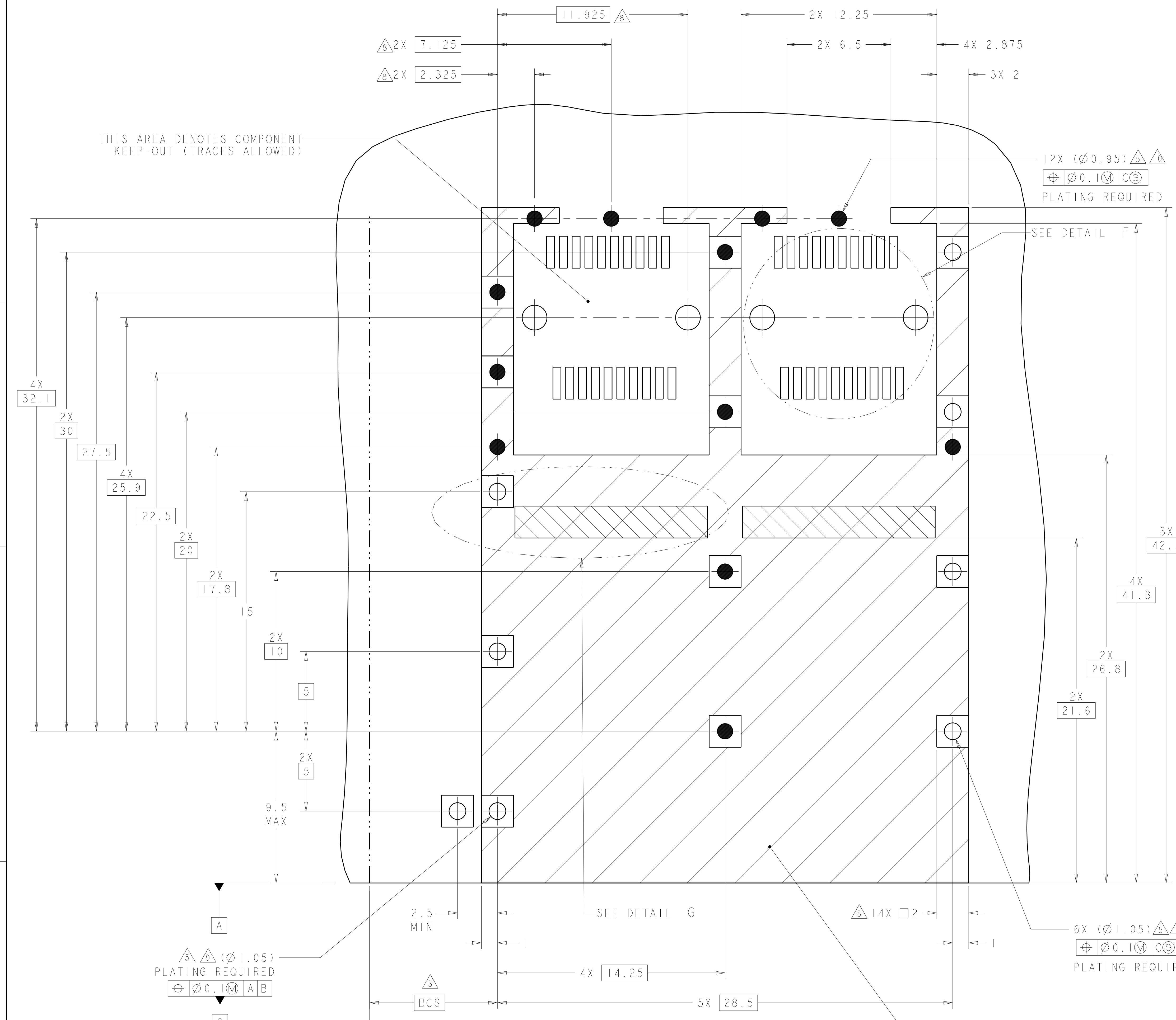

THIS AREA DENOTES COMPONENT KEEP-OUT (TRACES ALLOWED)

12X (Ø0.95) PLATING REQUIRED

SEE DETAIL F

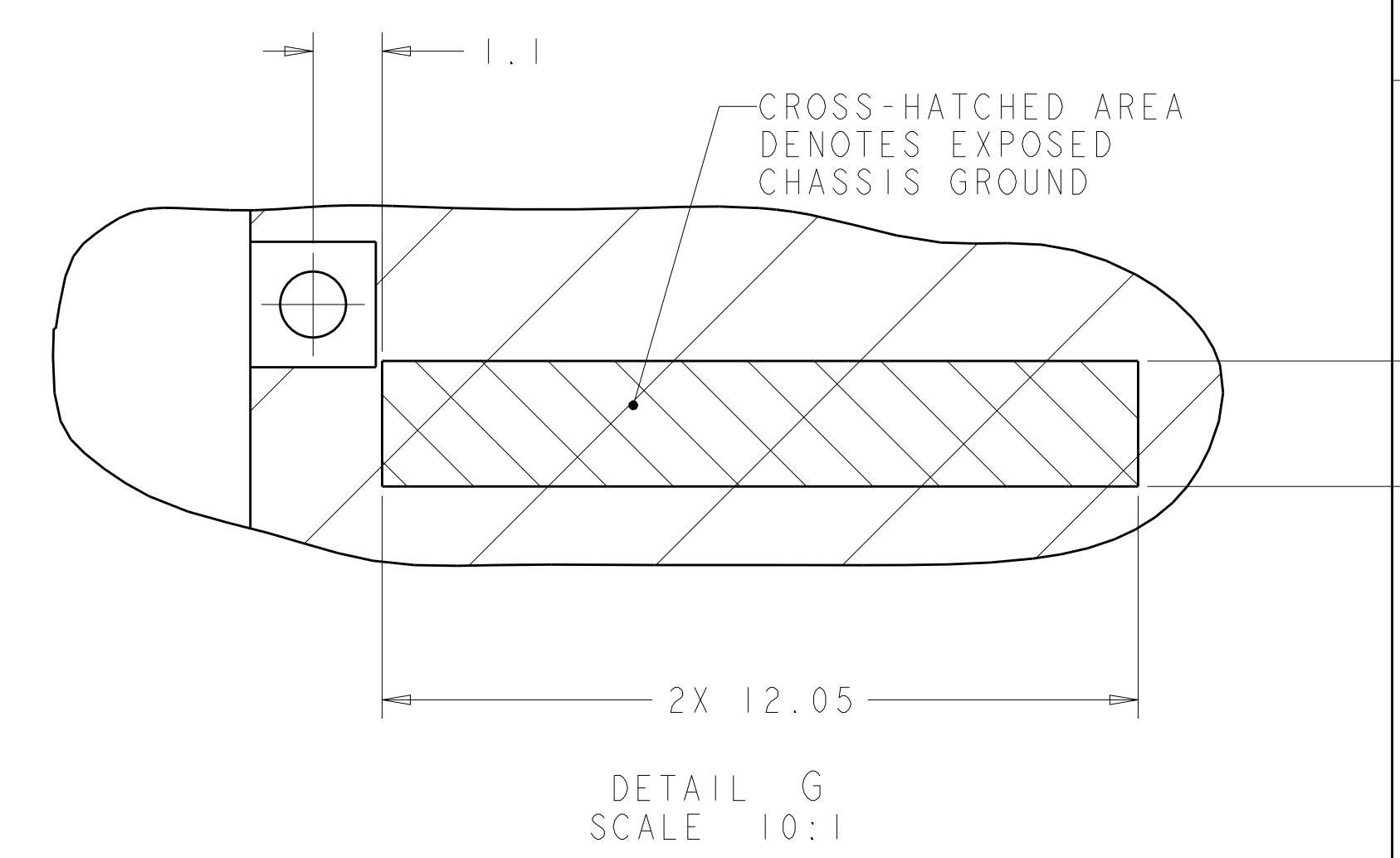
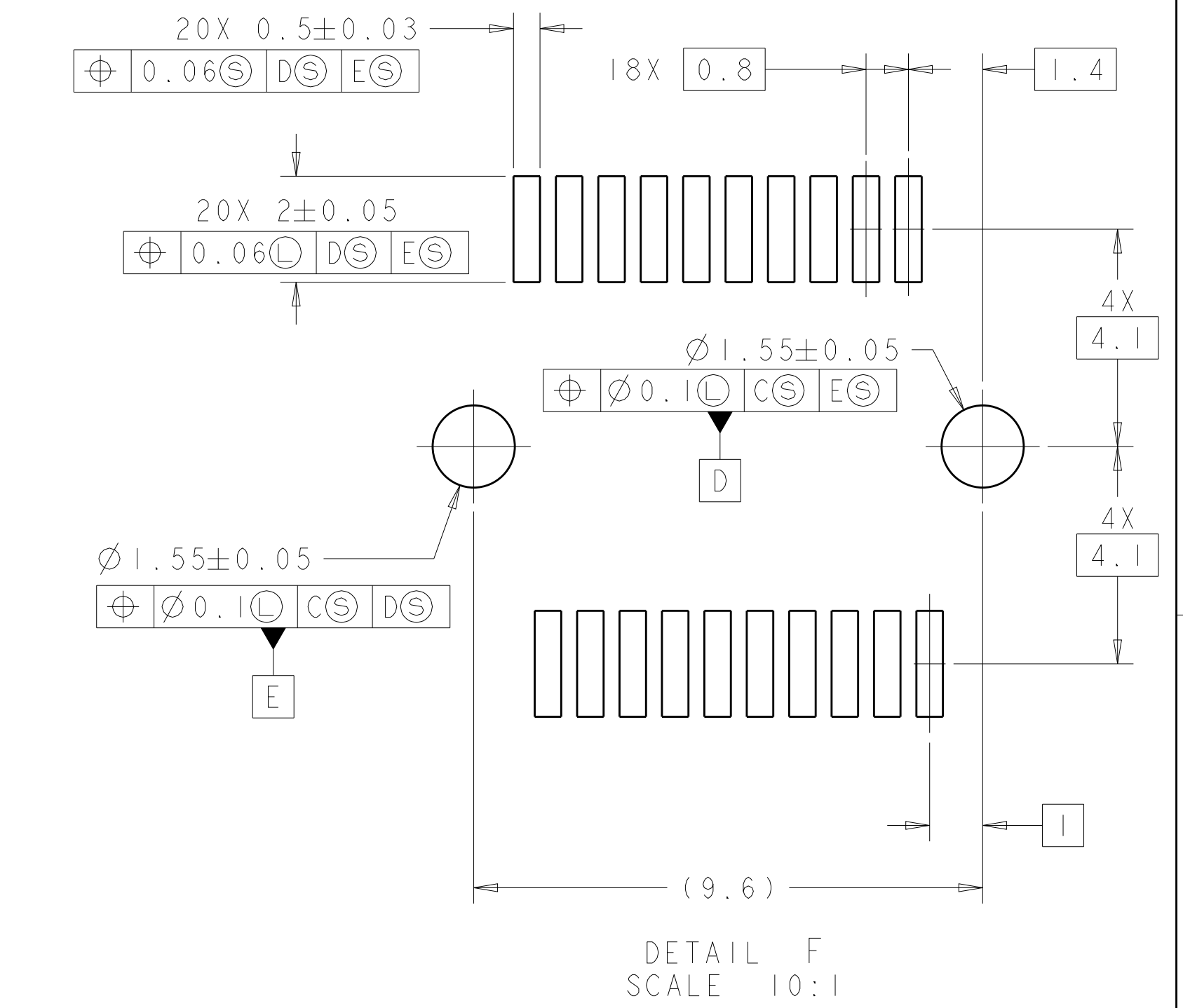

PLATING REQUIRED
Ø0.10

6X (Ø1.05) PLATING REQUIRED
Ø0.10

RECOMMENDED PCB CONFIGURATION WITH KEEP-OUT AREAS SINGLE SIDED APPLICATIONS SCALE 8:1

CROSS-HATCHED AREA DENOTES COMPONENT AND TRACE KEEP-OUT (EXCEPT CHASSIS GROUND)

THIS DRAWING IS A CONTROLLED DOCUMENT.		DWN: C. VALENTINE 06OCT2011	TE Connectivity
DIMENSIONS: mm		CHK: M. SCHMITT 06OCT2011	
TOLERANCES UNLESS OTHERWISE SPECIFIED:		APVD: M. SCHMITT 06OCT2011	NAME: SFP+ ENHANCED 1X2 CAGE ASSEMBLY, PRESS-FIT, EMI SPRINGS, HEAT SINK PRODUCT SPEC: 108-2364 APPLICATION SPEC: 114-13120
0 PLC ±0.13		SIZE: CAGE CODE DRAWING NO: A100779C=2198230	
1 PLC ±0.1		RESTRICTED TO: -	
2 PLC ±0.08		SCALE: 6:1 SHEET 3 OF 4 REV B	
3 PLC ±0.05			
4 PLC ±0.05			
ANGLES ±0.5			
MATERIAL FINISH: -			
WEIGHT: -			
Customer Drawing			

LOC	DIST	REV	DATE	APPD
GP	00			

REVISIONS				
NO.	DESCRIPTION	DATE	BY	APPD
1	SEE SHEET 1			

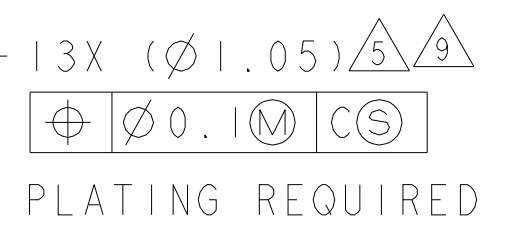
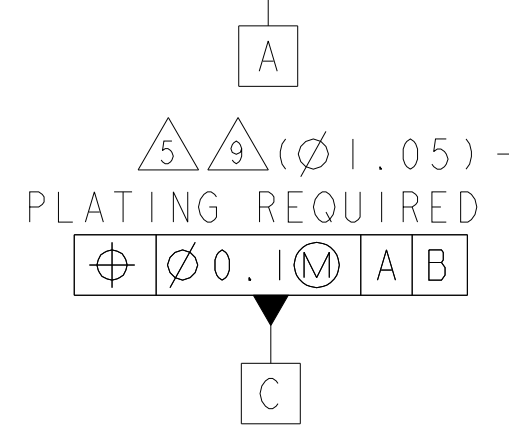
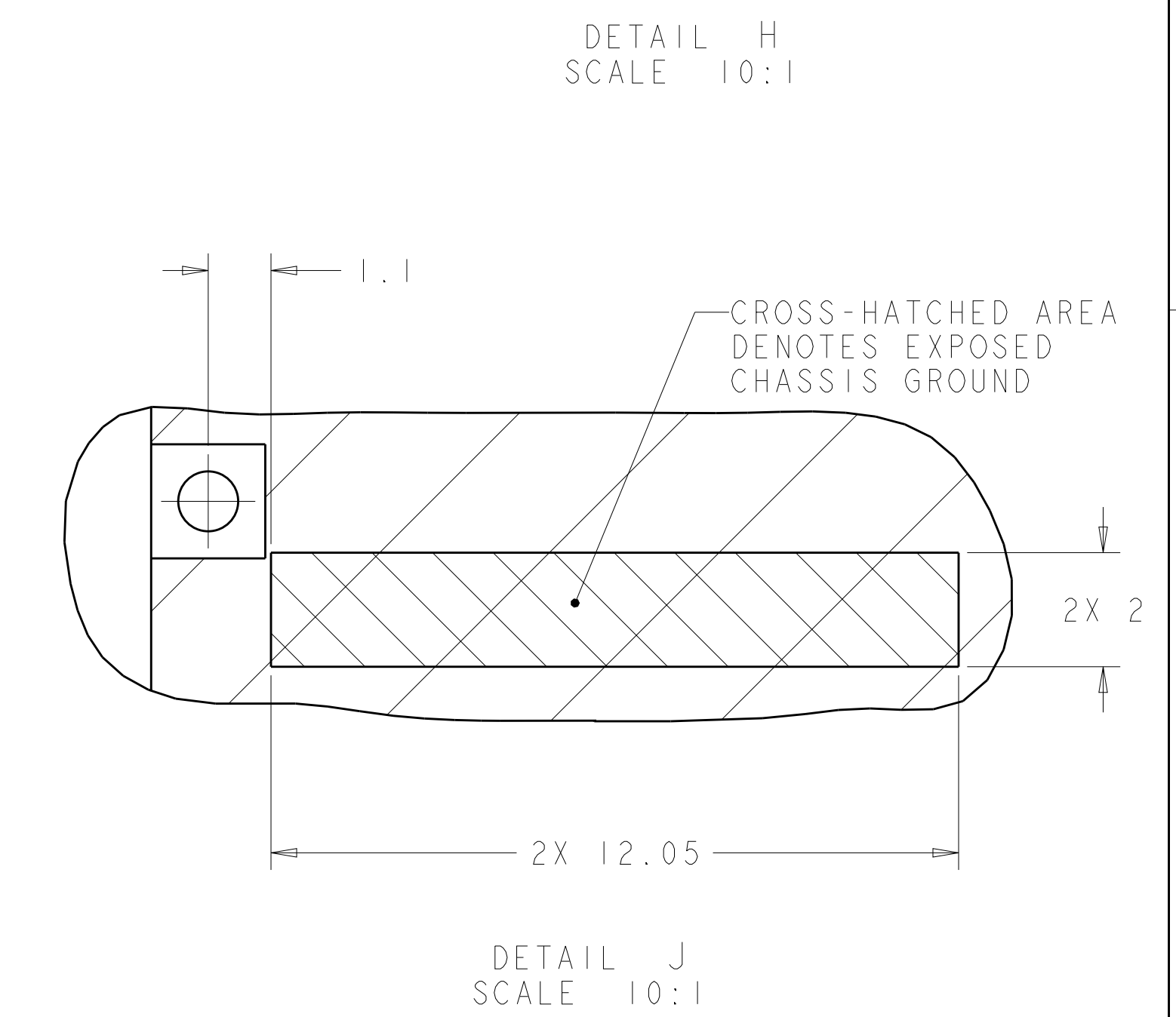
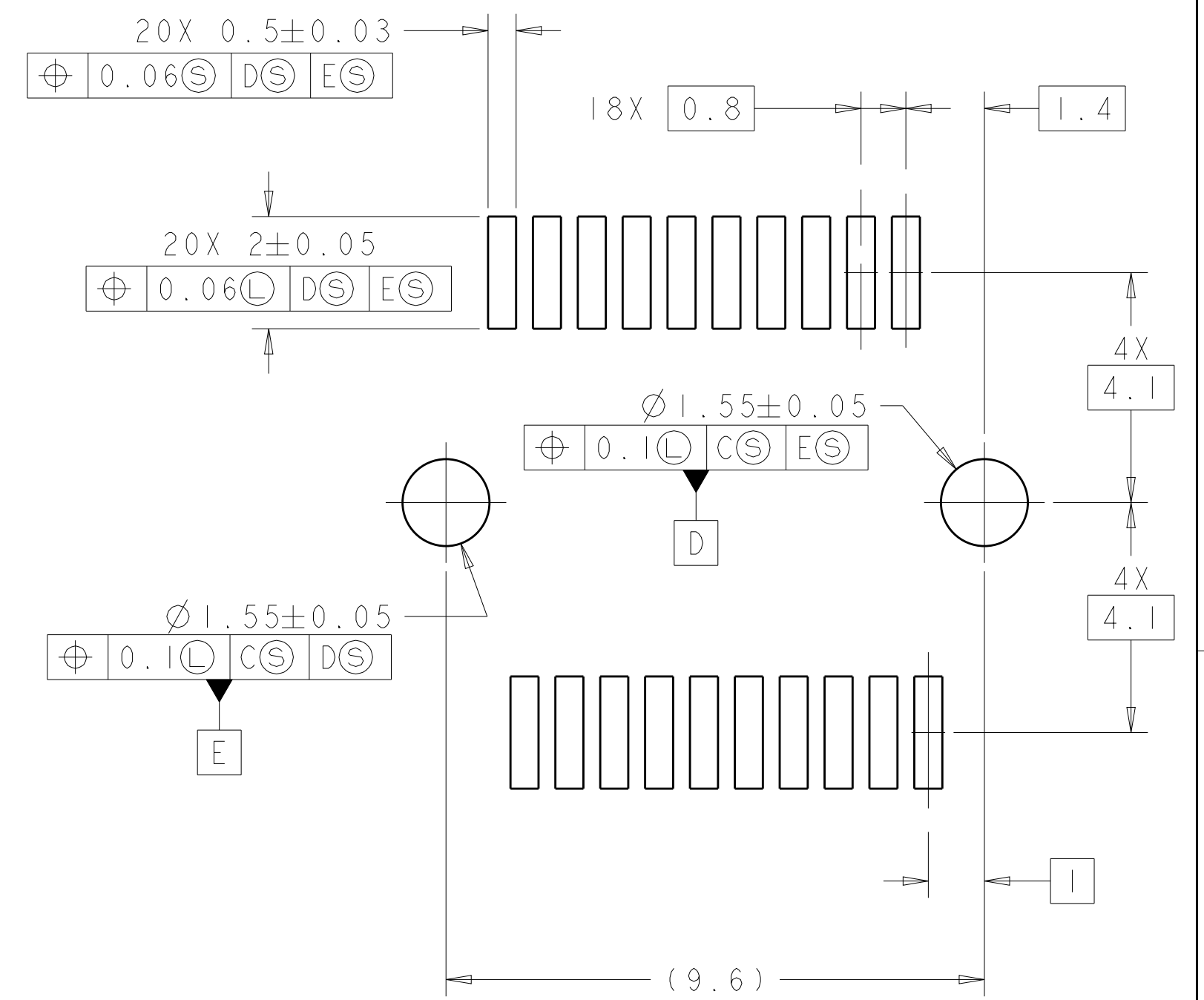
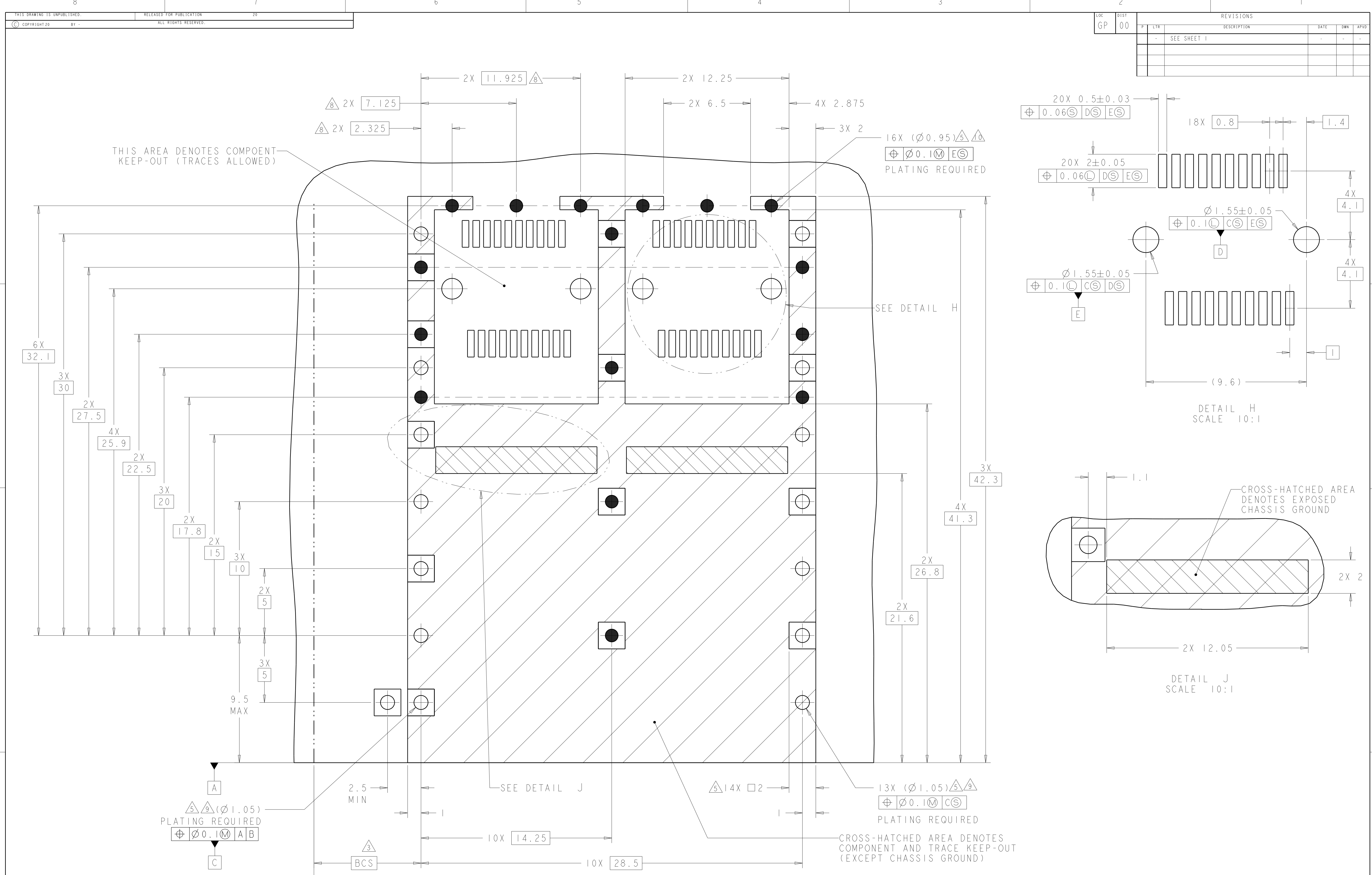

RECOMMENDED PCB CONFIGURATION WITH KEEP-OUT AREAS BELLY TO BELLY APPLICATIONS SCALE 8:1

THIS DRAWING IS A CONTROLLED DOCUMENT.		OWN: C. VALENTINE 06OCT2011	TE Connectivity
DIMENSIONS: mm		CHK: M. SCHMITT 06OCT2011	
TOLERANCES UNLESS OTHERWISE SPECIFIED:		APPD: M. SCHMITT 06OCT2011	NAME: SFP+ ENHANCED 1X2 CAGE ASSEMBLY, PRESS-FIT, EMI SPRINGS, HEAT SINK PRODUCT SPEC: 108-2364 APPLICATION SPEC: 114-13120 WEIGHT: - SCALE: 6:1 SHEET 4 OF 4 REV B
0 PLC ±0.13		PRODUCT SPEC: 108-2364	
1 PLC ±0.1		APPLICATION SPEC: 114-13120	
2 PLC ±0.08		WEIGHT: -	
3 PLC ±0.05		SIZE: CAGE CODE DRAWING NO: A100779C=2198230	RESTRICTED TO: -
4 PLC ±0.05		Customer Drawing	SCALE: 6:1 SHEET 4 OF 4 REV B
ANGLES: ±1			
MATERIAL: FINISH: #1			

Компания «Life Electronics» занимается поставками электронных компонентов импортного и отечественного производства от производителей и со складов крупных дистрибьюторов Европы, Америки и Азии.

С конца 2013 года компания активно расширяет линейку поставок компонентов по направлению коаксиальный кабель, кварцевые генераторы и конденсаторы (керамические, пленочные, электролитические), за счёт заключения дистрибьюторских договоров

Мы предлагаем:

- Конкурентоспособные цены и скидки постоянным клиентам.
- Специальные условия для постоянных клиентов.
- Подбор аналогов.
- Поставку компонентов в любых объемах, удовлетворяющих вашим потребностям.
- Приемлемые сроки поставки, возможна ускоренная поставка.
- Доставку товара в любую точку России и стран СНГ.
- Комплексную поставку.
- Работу по проектам и поставку образцов.
- Формирование склада под заказчика.
- Сертификаты соответствия на поставляемую продукцию (по желанию клиента).
- Тестирование поставляемой продукции.
- Поставку компонентов, требующих военную и космическую приемку.
- Входной контроль качества.
- Наличие сертификата ISO.

В составе нашей компании организован Конструкторский отдел, призванный помогать разработчикам, и инженерам.

Конструкторский отдел помогает осуществить:

- Регистрацию проекта у производителя компонентов.
- Техническую поддержку проекта.
- Защиту от снятия компонента с производства.
- Оценку стоимости проекта по компонентам.
- Изготовление тестовой платы монтаж и пусконаладочные работы.



Тел: +7 (812) 336 43 04 (многоканальный)

Email: org@lifeelectronics.ru