

General Description

The MIC2298 is a high power boost-switching regulator that is optimized for constant-current control. The MIC2298 is capable of driving up to 2 series 1A white LED for photoflash, flashlight and other applications. The feedback voltage is only 200mV, minimizing ballast power dissipation in constant-current control applications for improved operating efficiency.

The MIC2298 has a brightness pin that allows for a programmable torch mode as well full flash with a single pin when driving high current LEDs.

The MIC2298 implements a constant frequency 1MHz PWM control scheme to make the smallest possible design.

The 2.5V to 10V input voltage range of MIC2298 allows direct operation from 1- and 2-cell Li Ion as well as 3- to 6-cell NiCad/NiMH/Alkaline battery sources. Maximum battery life is assured with a low 1µA shutdown current.

The MIC2298 is available in a low profile 12-pin 3x3 MLF® package.

Data sheets and support documentation can be found on Micrel's web site at www.micrel.com.

Features

- 3.5A minimum switch current delivers at least 7W of output power over-temperature
- 200mV ±10% feedback voltage
- 2.5V to 10V input voltage
- Output voltage up to 30V (max)
- 12-pin 3mm x 3mm leadless MLF® package
- Available output over-voltage protection (OVP)
- 1MHz operation
- Programmable output current
- <1% line regulation
- 1µA shutdown current
- Over temperature protection
- Externally programmable soft-start
- Under-voltage lockout (UVLO)
- -40°C to +125°C junction temperature range

Applications

- Cell phones
- PDAs
- Digital cameras
- White LED flashlights

Typical Application

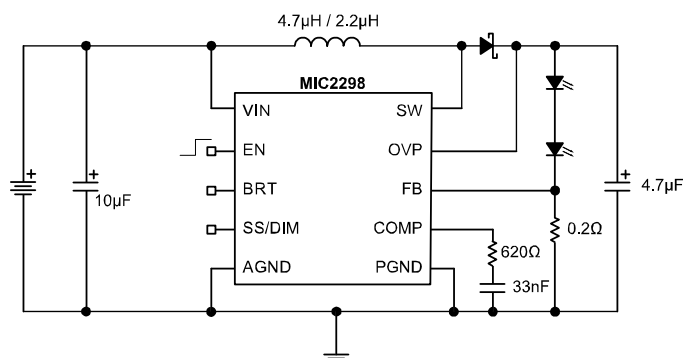

Figure 1. High Power White LED Driver

Ordering Information

Part Number	OVP	Frequency	Junction Temp. Range	Package	Lead Finish
MIC2298-15YML	15V	1MHz	-40° to +125°C	12-Pin 3x3 MLF [®]	Pb-Free

Note: MLF[®] is a GREEN RoHS compliant package. Lead finish is NiPdAu. Mold compound is Halogen Free.

Pin Configuration

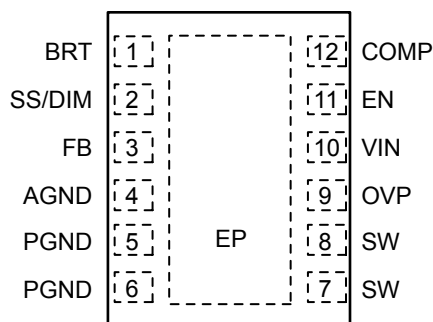

**12-Pin 3mm x 3mm MLF (ML)
(Top View)**

Pin Description

Pin Number	Pin Name	Pin Function
1	BRT	BRT (input): Apply a voltage greater than or equal to 1V to achieve full brightness current as determined by the ballast resistor. A 10 μ A current source sets the voltage on the resistor. Hence a 50K resistor would yield 0.5V which causes a reduction in LED current to 50% of full brightness. Grounding the BRT reduces the current further to 20% of full brightness. This pin may also be driven by a PWM signal for the same effect.
2	SS/DIM	Soft start/dimming (input) 40k Ω source. Connect a capacitor to GND for soft-start. Clamp the pin to a known voltage to control the internal reference voltage and hence the output current. This can also be done with a resistor to GND
3	FB	Feedback (Input): Output voltage sense node. Connect the cathode of the LED to this pin.
4	AGND	Analog Ground
5,6	PGND	Power Ground
7,8	SW	Switch Node: Internal power BIPOLAR collector.
9	OVP	Over-Voltage Protection (OVP): Connect to the output voltage to clamp the maximum output voltage. A resistor divider from this pin to ground could be used to raise the OVP level beyond 15V (max)
10	VIN	Supply (Input): 2.5V to 10V for internal circuitry.
11	EN	Enable (Input): Applying 1.5V or greater enables the regulator. Applying a voltage of 0.4V or less disables the MIC2298.
12	COMP	Compensation pin (input): Add external R and C to GND to stabilize the converter.
Pad	EP	Ground (Return): Backside exposed pad.

Absolute Maximum Ratings⁽¹⁾

Supply Voltage (V_{IN}).....	12V
Switch Voltage (V_{SW}).....	-0.3V to 34V
BRT Voltage (V_{BRT}).....	-0.3V to 6V
SS/DIM Voltage (V_{SS}).....	-0.3V to 6V
Enable Voltage (V_{EN}).....	-0.3V to 12V
FB Voltage (V_{FB}).....	6V
Switch Current (I_{SW}).....	6A
Ambient Storage Temperature (T_s).....	-65°C to +150°C
ESD Rating ⁽³⁾	2kV

Operating Ratings⁽²⁾

Supply Voltage (V_{IN}).....	2.5V to 10V
BRT Voltage (V_{BRT}).....	0V to 0.6 V_{IN}
Enable Voltage (V_{EN}).....	0V to V_{IN}
Output Voltage (V_{OUT}).....	$V_{IN} + 1$ to V_{OVP}
Junction Temperature (T_J).....	-40°C to +125°C
Package Thermal Impedance	
3x3 MLF-12 (θ_{JA}).....	60°C/W

Electrical Characteristics⁽⁴⁾

$T_A = 25^\circ\text{C}$; $V_{IN} = V_{EN} = 3.6\text{V}$; $V_{OUT} = 7\text{V}$; $I_{OUT} = 1\text{A}$, unless otherwise noted. **Bold** values indicate $-40^\circ\text{C} \leq T_J \leq +125^\circ\text{C}$.

Symbol	Parameter	Condition	Min	Typ	Max	Units
V_{IN}	Supply Voltage Range		2.5		10	V
V_{UVLO}	Under-Voltage Lockout		1.8	2.1	2.4	V
V_{OVP}	Over-Voltage Protection		12	13.5	15	V
I_{VIN}	Quiescent Current	$V_{FB} > 200\text{mV}$, Not Switching		15	23	mA
I_{SD}	Shutdown Current	$V_{EN} = 0\text{V}$ (Note 5)		0.1	1	μA
V_{FB}	Feedback Voltage	(+/-8%) (+/-10%) (Over Temp)	184 180	200	216 220	mV
I_{FB}	Feedback Input Current	$V_{FB} = 200\text{mV}$		-650		nA
	Line Regulation	$2.5\text{V} \leq V_{IN} \leq 4.5\text{V}$		0.5		%
I_{LED}	BRT accuracy (Note 6)	$R_{BRT} = \text{GND}$ $R_{BRT} = 50\text{K}$	17 45	20 50	23 55	%
D_{MAX}	Maximum Duty Cycle		85	90		%
I_{SW}	Switch Current Limit	$V_{IN} = 3\text{V}$	3.5	4.75	8	A
V_{SW}	Switch Saturation Voltage	$V_{IN} = 3.6\text{V}$, $I_{SW} = 3.5\text{A}$		350	500	mV
I_{SW}	Switch Leakage Current	$V_{EN} = 0\text{V}$, $V_{SW} = 15\text{V}$		0.01	10	μA
V_{EN}	Enable Threshold	TURN ON TURN OFF	1.5		0.4	V
I_{EN}	Enable Pin Current	$V_{EN} = 10\text{V}$		20	40	μA
f_{SW}	Oscillator Frequency		0.8	1	1.2	MHz
I_{SS}	Soft start / DIM current	DIM = 0V		5		μA
T_J	Over-Temperature Threshold Shutdown			150		$^\circ\text{C}$
		Hysteresis		10		$^\circ\text{C}$

Notes:

1. Absolute maximum ratings indicate limits beyond which damage to the component may occur. Electrical specifications do not apply when operating the device outside of its operating ratings. The maximum allowable power dissipation is a function of the maximum junction temperature, $T_{J(\text{Max})}$, the junction-to-ambient thermal resistance, θ_{JA} , and the ambient temperature, T_A . The maximum allowable power dissipation will result in excessive die temperature, and the regulator will go into thermal shutdown.
2. The device is not guaranteed to function outside its operating rating.
3. Devices are ESD sensitive. Handling precautions recommended.
4. Specification for packaged product only.
5. $I_{SD} = I_{VIN}$
6. As percentage of full brightness where $V_{IN} = V_{BRT} = 3.6\text{V}$ (100% brightness)

Typical Characteristics

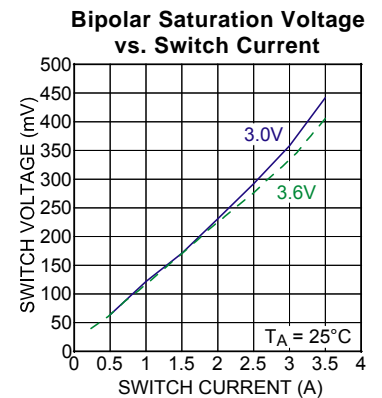
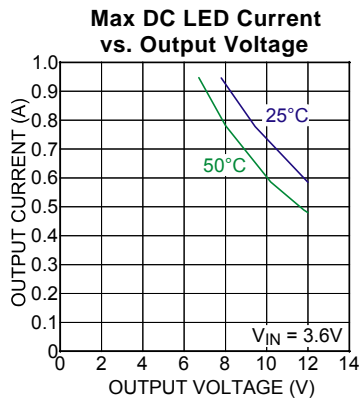
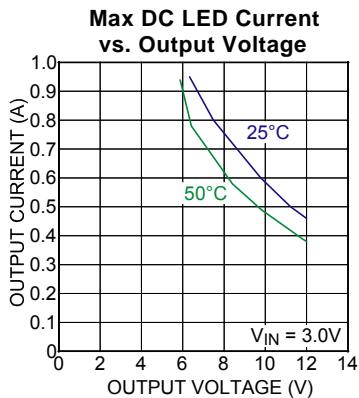
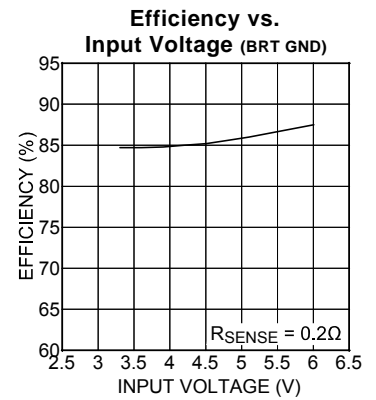
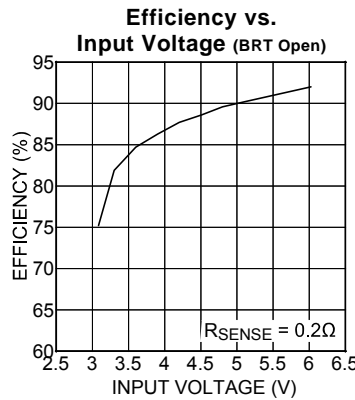
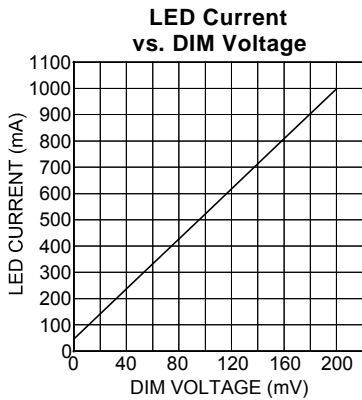
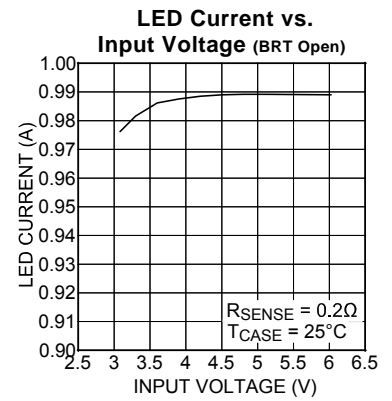
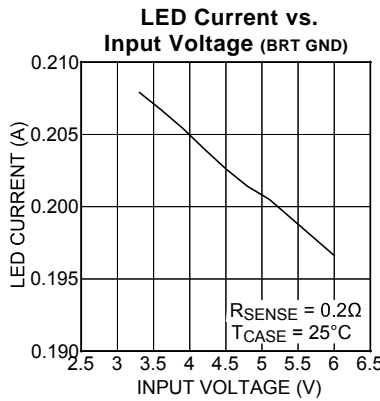
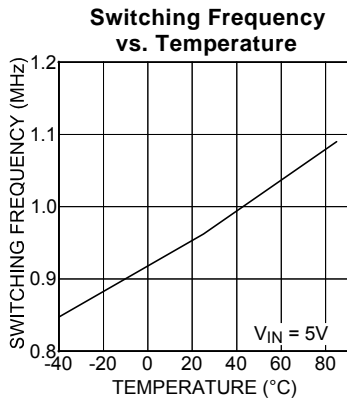
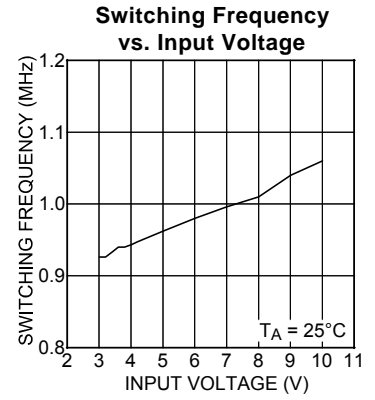
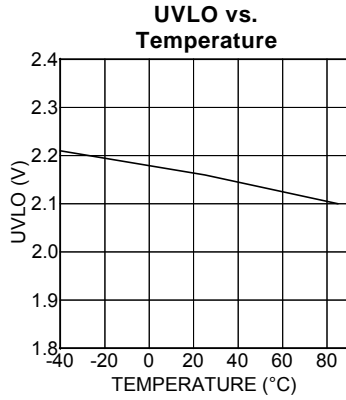
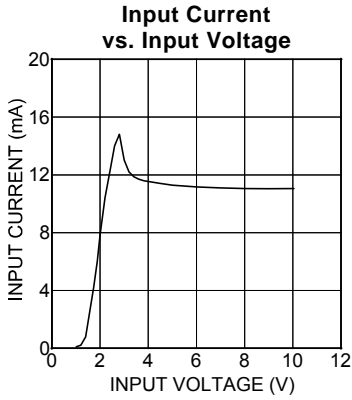

Functional Characteristics

Enable (1A LED)

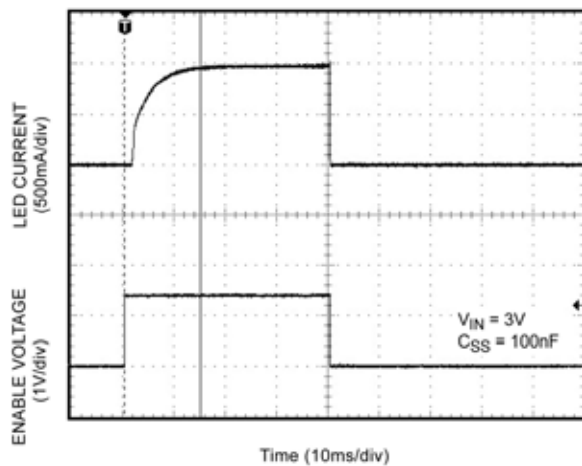

Enable (1A LED)

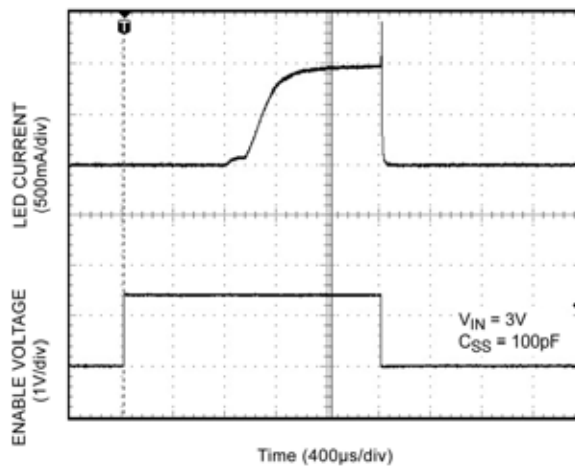

Enable (Frequency = 67Hz)

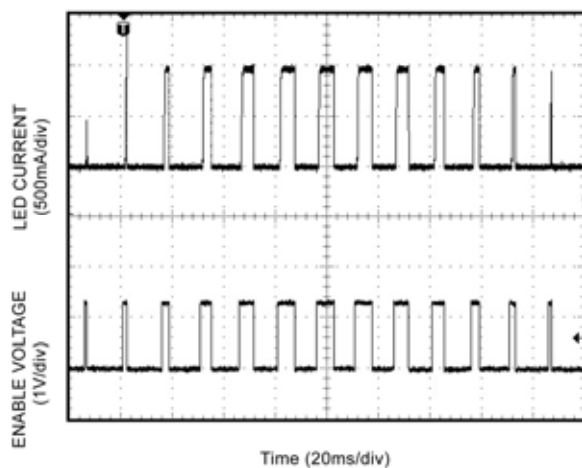

Switching

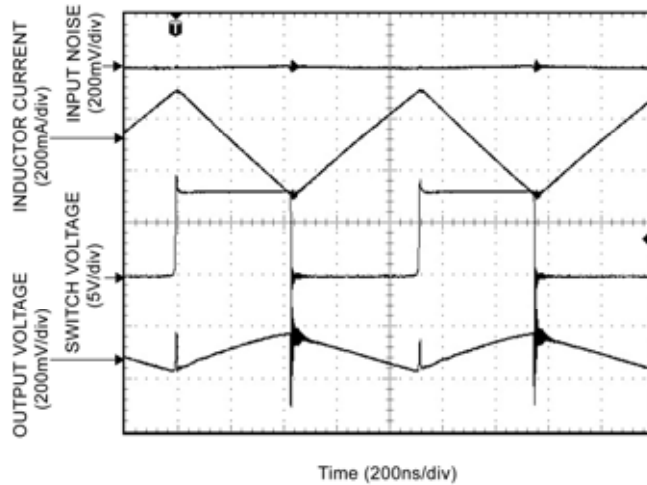

Functional Diagram

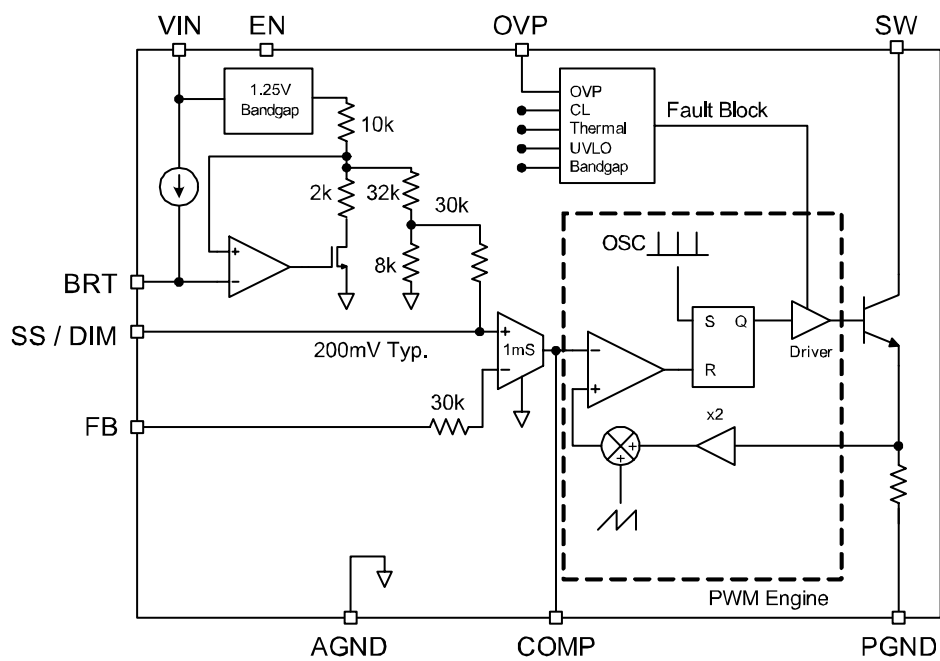

Figure 2. MIC2298 Block Diagram

Functional Description

The MIC2298 is a constant frequency, pulse-width-modulated (PWM) peak current-mode step-up regulator. The MIC2298 simplified control scheme is illustrated in the block diagram in Figure 2. A reference voltage is fed into the PWM engine where the duty cycle output of the constant frequency PWM engine is computed from the error, or difference, between the REF and FB voltages. The PWM engine encompasses the necessary circuit blocks to implement a current-mode boost switch-mode power supply. The necessary circuit blocks include, but are not limited to, an oscillator/ramp generator, slope compensation ramp generator, g_m error amplifier, current amplifier, PWM comparator, and drive logic for the internal 3.5A bipolar power transistor.

Inside the PWM engine, the oscillator functions as a trigger for the PWM comparator that turns on the bipolar power transistor and resets the slope compensation ramp generator. The current amplifier is used to measure the power transistor's current by amplifying the voltage signal from the CS+ and CS- inputs from the sense resistor connected to the emitter of the bipolar power transistor. The output of the current amplifier is summed with the output of the slope compensation ramp generator where the result is connected to one of the inputs of the PWM comparator.

The g_m error amplifier measures the white LED current through the external sense resistor and amplifies the error between the detected voltage signal from the feedback, or FB pin and the internal reference voltage. The output of the g_m error amplifier provides the voltage loop signal that is fed to the other input of the PWM comparator. When the current loop signal exceeds the voltage loop signal the PWM comparator turns off the power transistor. The next oscillator/clock period initiates the next switching cycle, maintaining the constant frequency current-mode PWM control. The maximum white LED current is set by the feedback resistor (the resistor connected from the feedback pin to ground):

$$I_{LED} = \frac{200mV}{R_{FB}}$$

The enable pin shuts down the output switching and disables control circuitry to reduce input current-to-leakage levels. Enable pin input current is zero at zero volts.

DC-to-DC PWM Boost Conversion

The MIC2298 is a constant-frequency boost converter. It operates by taking a DC input voltage and regulating a DC output voltage. Figure 3 shows a typical circuit. Boost regulation is achieved by turning on an internal switch, which draws current through the inductor (L1). When the switch turns off, the inductor's magnetic field collapses. This causes the current to be discharged into the output capacitor through an external Schottky diode

(D1). Waveforms 4 and 5 show Input Voltage ripple, Output Voltage ripple, SW Voltage, and Inductor Current for 900mA LED current. Regulation is achieved by modulating the pulse width i.e., pulse-width modulation (PWM).

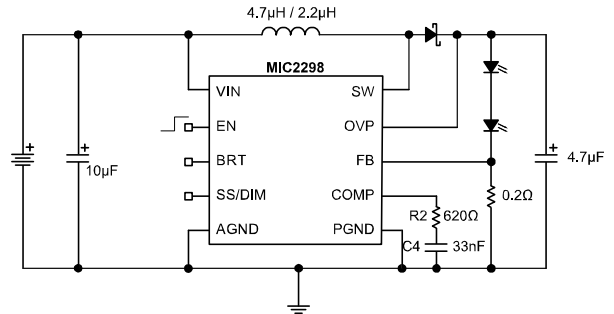

Figure 3. Typical Application Circuit

Duty Cycle Considerations

Duty cycle refers to the switch on-to-off time ratio and can be calculated as follows for a boost regulator:

$$D = 1 - \frac{V_{in}}{V_{out}}$$

However, at light loads the inductor will completely discharge before the end of a switching cycle. The current in the inductor reaches 0A before the end of the switching cycle. This is known as discontinuous conduction mode (DCM). DCM occurs when:

$$I_{out} < \frac{V_{in}}{V_{out}} \cdot \frac{I_{peak}}{2}$$

Where

$$I_{peak} = \frac{(V_{out} - V_{in})}{L \cdot f} \cdot \left(\frac{V_{in}}{V_{out}} \right)$$

In DCM, the duty cycle is smaller than in continuous conduction mode. In DCM the duty cycle is given by:

$$D = \frac{f \cdot \sqrt{2 \cdot L \cdot I_{out} \cdot (V_{out} - V_{in})}}{V_{in}}$$

The duty cycle required for voltage conversion should be less than the maximum duty cycle of 95%. Also, in light load conditions where the input voltage is close to the output voltage, the minimum duty cycle can cause pulse skipping. This is due to the energy stored in the inductor causing the output to slightly overshoot the regulated output voltage. During the next cycle, the error amplifier detects the output as being high and skips the following pulse. This effect can be reduced by increasing the minimum load or by increasing the inductor value. Increasing the inductor value also reduces the peak current.

Over-Voltage Protection

The MIC2298 offers over-voltage protection functionality. If an LED is disconnected from the circuit or the feedback pin is shorted to ground, the feedback pin will fall to ground potential. This will cause the MIC2298 to switch at full duty cycle in an attempt to maintain the feedback voltage. As a result, the output voltage will climb out of control. This may cause the switch node voltage to exceed its maximum voltage rating, possibly damaging the IC and the external components. To ensure the highest level of protection, the MIC2298 OVP pin will shut the switch off when an over-voltage condition is detected, saving itself and the output capacitor from damage. The OVP threshold can be increased by adding a resistor divider between the output and ground. Be careful not to exceed the 30V rating of the switch.

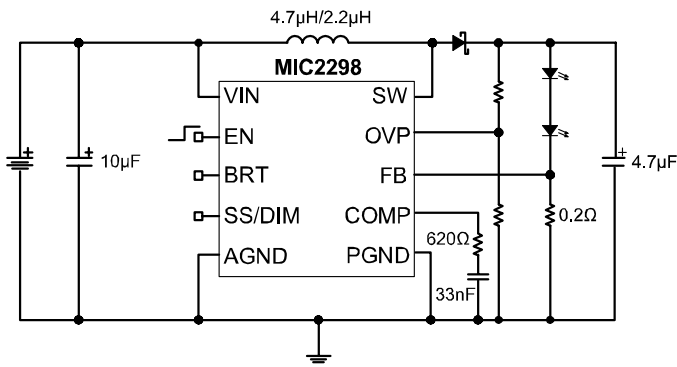

Figure 4. Adjustable OVP Circuit

Brightness Control

Pin Brightness Functionality

BRT Pin	V _{FB} (V)
OPEN	200mV or V _{SS/DIM}
GND	40mV
≥20kΩ to 100kΩ [R _{BRT}] to GND	(10µA × R _{BRT})/5

SS/DIM Pin	V _{FB} (V)
OPEN	200mV
Voltage v	V _{FB} = v

Table 1. BRT and SS/DIM Brightness Control Functionality

The MIC2298 has built in brightness/dimming functionality for white LED applications. The BRT and SS/DIM pins are available for brightness/dimming control functionality. Table 1 illustrates the different modes of dimming functionality afforded by the BRT and SS/DIM pins. The resulting LED current is then calculated as:

$$I_{LED} = V_{FB}/R_{SENSE}$$

Hence, a 200mΩ sense resistor will achieve nominally 1A when both DIM and BRT pins are left open.

PWM control of brightness

A control signal can be driven into the enable pin to vary average current through the LED for applications not sensitive to low frequency (~100Hz) light modulation. For such applications, the SS/DIM pin capacitance should be minimized to achieve a fast turn on time. 0nF will achieve approximately 1.5ms with a C_{COMP} value of 33nF.

For other applications, where no analog control voltage is available, the BRT pin can be driven through a low pass filter (18kΩ and 470nF) at a PWM frequency of >5kHz to set the FB voltage, and therefore, the LED current from 20% to 100% of Nominal LED current (Figure 5).

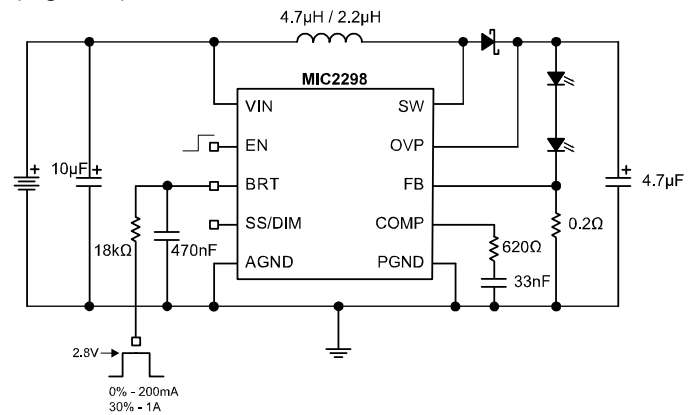

Figure 5. High Frequency PWM Programming Via BRT Pin

Since the DIM pin is typically utilized for soft start, it is recommended to use the enable and BRT pins for the PWM method of adjusting the average LED current. Figures 6 and 7 below show typical results for this method.

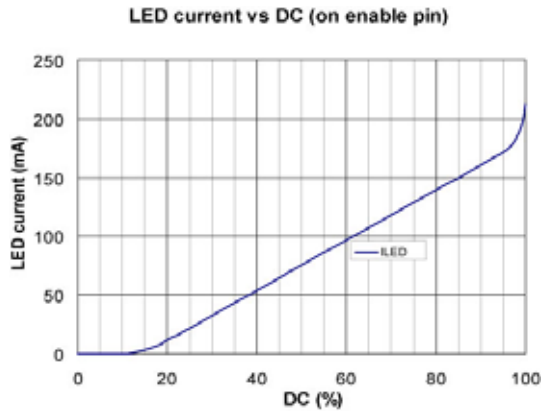

Figure 6. LED Current vs. DC (on enable pin)

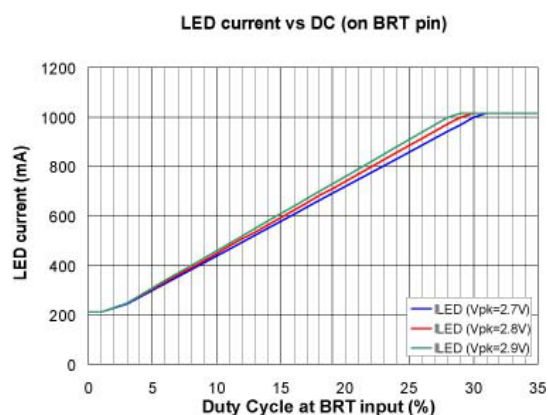

Figure 7. LED Current vs. DC (on BRT pin)

Should the SS/DIM pin be used for voltage programming the LED current, note that there will be a small offset due to mismatches between the 30k FB input and the impedance driving the SS/DIM pin.

Soft Start Functionality

The soft start time is dependant up on both C_{SS} and the comp capacitor values. C_{COMP} is fixed for stable operation (typically 33nF); therefore, if any increases in soft start are desired, this should be done using the C_{SS} capacitor. The approximate total startup time is given by the larger of: -

$$T_{SS} = 1ms + 175k \cdot C_{SS}$$

Or

$$T_{SS} = 1ms + C_{COMP} / 44 \cdot 10^{-6}$$

E.g. for $C_{COMP} = 33nF$, use values of $C_{COMP} > 4.3nF$ to increase startup time from 1.75ms. The soft start capacitor should be connected from the SS/DIM pin to ground.

Component Selection

Inductor

Inductor selection is a balance between efficiency, stability, cost, size, and rated current. For most applications, a 4.7μH is the recommended inductor value. It is usually a good balance between these considerations. Larger inductance values reduce the peak-to-peak ripple current, affecting efficiency. This has the effect of reducing both the DC losses and the transition losses. There is also a secondary effect of an inductor's DC resistance (DCR). The DCR of an inductor will be higher for more inductance in the same package size. This is due to the longer windings required for an increase in inductance. Since the majority of input current (minus the MIC2298 operating current) is passed through the inductor, higher DCR inductors will reduce efficiency. To maintain stability, increasing inductor size will have to be met with an increase in output capacitance. This is due to the unavoidable "right half plane zero" effect for the continuous current boost converter topology. The frequency at which the right half plane zero occurs can be calculated as follows:

$$f_{rhpz} = \frac{V_{IN}^2}{V_{OUT} \cdot L \cdot I_{OUT} \cdot 2\pi}$$

The right half plane zero has the undesirable effect of increasing gain, while decreasing phase. This requires that the loop gain is rolled off before this has significant effect on the total loop response. This can be accomplished by either reducing inductance (increasing RHPZ frequency) or increasing the output capacitor value (decreasing loop gain).

Output Capacitor

Output capacitor selection is also a trade-off between performance, size, and cost. Increasing output capacitance will lead to an improved transient response, but also an increase in size and cost. X5R or X7R dielectric ceramic capacitors are recommended for designs with the MIC2298.

The output capacitor sets the frequency of the dominant pole and zero in the power stage. The zero is given by:

$$f_z = \frac{1}{C \cdot R_{esr} \cdot 2\pi}$$

For ceramic capacitors, the ESR is very small. This puts the zero at a very high frequency where it can be ignored. Fortunately, the MIC2298 is current mode in operation which reduces the need for this output capacitor zero when compensating the feedback loop.

The frequency of the pole caused by the output capacitor is given by.

$$f_p = \frac{I_{OUT}}{C \cdot V_{OUT} \cdot 2 \cdot \pi}$$

Diode Selection

The MIC2298 requires an external diode for operation. A Schottky diode is recommended for most applications due to their lower forward voltage drop and reverse recovery time. Ensure the diode selected can deliver the peak inductor current and the maximum reverse voltage is rated greater than the output voltage.

Input capacitor

A minimum 1μF ceramic capacitor with an X5R or X7R dielectric is recommended for designing with the MIC2298. Increasing input capacitance will improve performance and greater noise immunity on the source. The input capacitor should be as close as possible to the inductor and the MIC2298, with short traces for good noise performance.

The MIC2298 utilizes a feedback pin to compare the LED current to an internal reference. The LED current is adjusted by selecting the appropriate feedback resistor value. The desired output current can be calculated as follows:

$$I_{LED} = \frac{0.2V}{R}$$

Compensation

The comp pin is connected to the output of the voltage error amplifier. The voltage error amplifier is a transconductance amplifier. Adding a series RC-to-ground adds a zero at:

$$f_{zero} = \frac{1}{2\pi R_2 C_4}$$

The resistor typically ranges from 1kΩ to 50kΩ. The capacitor typically ranges from 1nF to 100nF.

Adding an optional capacitor from comp pin-to-ground adds a pole at approximately

$$f_{pole} = \frac{1}{2\pi R_2 C_3}$$

This capacitor typically ranges from 100pF to 10nF. Generally, an RC to ground is all that is needed. The RC should be placed as close as possible to the compensation pin. The capacitor should be a ceramic with a X5R, X7R, or COG dielectric. Refer to the MIC2298 evaluation board document for component location.

Application Information

Grounding

Both the AGND and PGND must be connected to the exposed backside pad. The exposed backside pad also improves thermal performance. A large ground plane decreases thermal resistance to ambient air.

Thermal Considerations and the SOA

The SOA (safe operating area) of the MIC2298 is shown in the typical characteristics sub-section. This graph represents the maximum continuous output power capability of the part when used in the evaluation board layout. An alternative layout with more copper area for heat sinking will increase the area under the SOA curve. Note that the SOA is for continuous power and not peak power and is effectively a thermal limitation. The SOA is true for a time constant of approximately >1 second. Therefore, any load transient with a period of < 3s can exceed the SOA curve power up to a maximum limited by the current limit of the MIC2298. Figure 8 shows the theoretical output current limit of the MIC2298 using the Evaluation Board inductor value of 4.7µH.

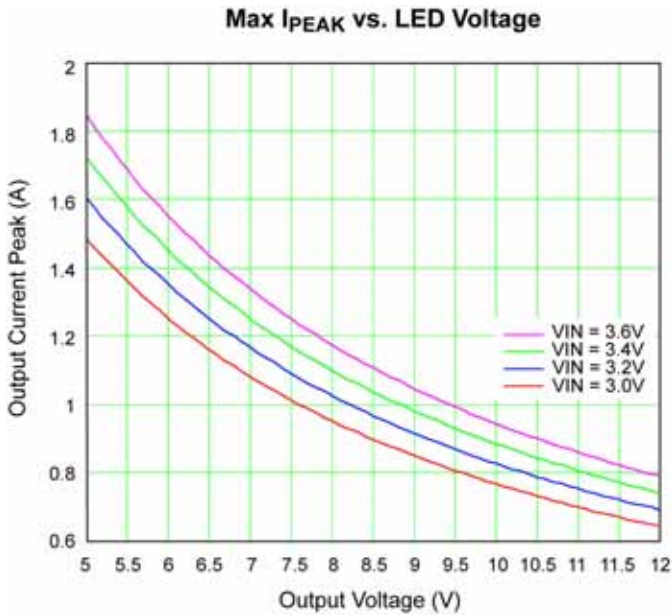

Figure 8. Peak Output Current vs. V_{OUT}

If our load is within these limits, it is possible to drive the load at some repetition rate or duty cycle (DC). This is allowed as long as we limit the RMS current to below the SOA limit.

The RMS current for a pulsed current is known to be $I_{RMS} = (I_{PK-PK} \cdot \sqrt{DC}) + I_{DC}$ where the current pulse I_{PK-PK} sits on a DC level of I_{DC} .

This simplifies to $I_{RMS} = I_{PK} \cdot \sqrt{DC}$ when there is no DC level.

The graph in Figure 9 shows the peak LED current which can be pulsed at a given duty cycle (DC) to stay within SOA limits of 400mA to 700mA.

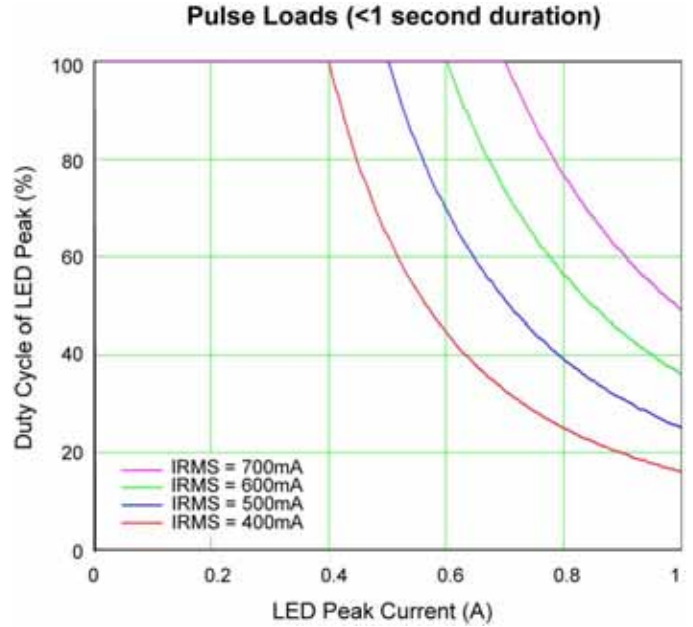

Figure 9. Duty Cycle vs. Peak Current for Fixed RMS Current

Example

Two series connected high brightness white LEDs with a V_f max of 4.2V and peak current of 800mA require pulses of 300ms at 3 second intervals. Power source is a Li-ion cell of 3v min.

- Looking at the SOA curves (Page 4, Max DC LED Current), these cannot be driven continuously.
- The time constant of the driver is < 3 seconds, so one can look at the peak current capability of the driver in Figure 8.
- Looking at Figure 8, the MIC2298 can achieve more than the required 800mA peak current at 8.4V.
- Reading from the SOA curve in the typical characteristics sub-section (Page 4, Max DC LED Current), the MIC2298 at 3V, 50°C and 8.4V output voltage, can provide 580mA RMS.
- Now looking at the curve in Figure 9, using the next lower value of 500mA RMS current, one can see that the 850mA peak can be driven at a duty cycle of ~33% (or 1 second out of every 3 seconds). That is well within our target of 300ms.

LED Protection

The operation of the Power LED must be limited to short pulses to prevent overheating. This is usually controlled by the micro controller in a typical application. For further protection, or where a micro controller is not used, the temperature of the LED can be limited by the addition of an NTC thermistor. The value should be $> 100k\Omega$ at its maximum safe temperature. This will then limit current drive to the LED as temperature rises further and prevents overheating. This thermistor should be connected directly from BRT to GND. Reference Figure 10.

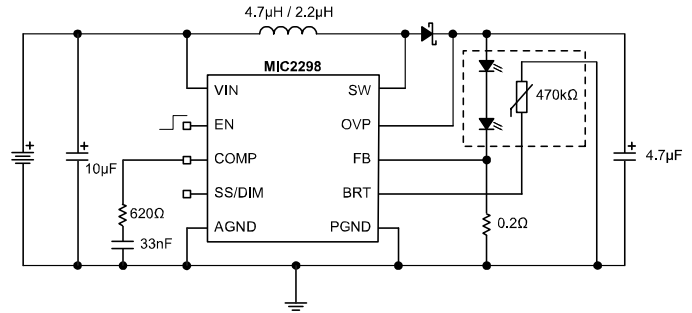
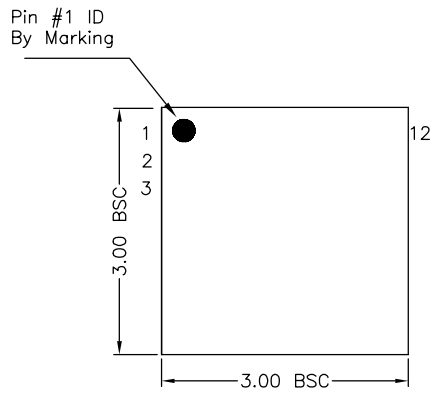
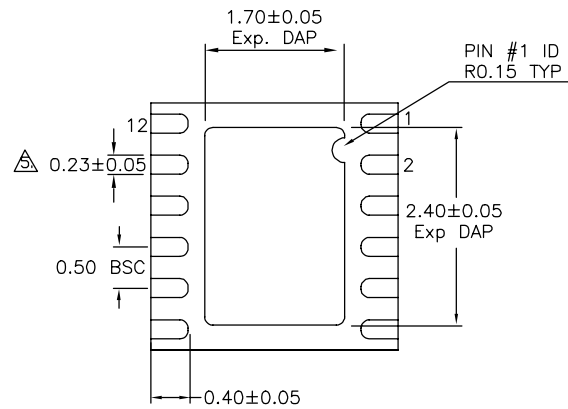

Figure 10. LED Thermal Protection

Package Information



TOP VIEW



BOTTOM VIEW

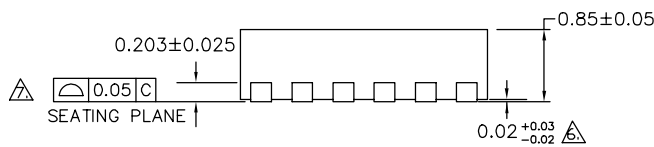

SIDE VIEW

- NOTE:
1. ALL DIMENSIONS ARE IN MILLIMETERS.
 2. MAX. PACKAGE WARPAGE IS 0.05 mm.
 3. MAXIMUM ALLOWABLE BURRS IS 0.076 mm IN ALL DIRECTIONS.
 4. PIN #1 ID ON TOP WILL BE LASER/INK MARKED.
- △ DIMENSION APPLIES TO METALIZED TERMINAL AND IS MEASURED BETWEEN 0.20 AND 0.25 mm FROM TERMINAL TIP.
- △ APPLIED ONLY FOR TERMINALS.
- △ APPLIED FOR EXPOSED PAD AND TERMINALS.

12-Pin 3mm x 3mm MLF[®] (ML)

MICREL, INC. 2180 FORTUNE DRIVE SAN JOSE, CA 95131 USA
 TEL +1 (408) 944-0800 FAX +1 (408) 474-1000 WEB <http://www.micrel.com>

The information furnished by Micrel in this data sheet is believed to be accurate and reliable. However, no responsibility is assumed by Micrel for its use. Micrel reserves the right to change circuitry and specifications at any time without notification to the customer.

Micrel Products are not designed or authorized for use as components in life support appliances, devices or systems where malfunction of a product can reasonably be expected to result in personal injury. Life support devices or systems are devices or systems that (a) are intended for surgical implant into the body or (b) support or sustain life, and whose failure to perform can be reasonably expected to result in a significant injury to the user. A Purchaser's use or sale of Micrel Products for use in life support appliances, devices or systems is a Purchaser's own risk and Purchaser agrees to fully indemnify Micrel for any damages resulting from such use or sale.

© 2007 Micrel, Incorporated.

Mouser Electronics

Authorized Distributor

Click to View Pricing, Inventory, Delivery & Lifecycle Information:

[Micrel:](#)

[MIC2298-15YML TR](#) [MIC2298-15YML-TR](#)

Компания «Life Electronics» занимается поставками электронных компонентов импортного и отечественного производства от производителей и со складов крупных дистрибьюторов Европы, Америки и Азии.

С конца 2013 года компания активно расширяет линейку поставок компонентов по направлению коаксиальный кабель, кварцевые генераторы и конденсаторы (керамические, пленочные, электролитические), за счёт заключения дистрибьюторских договоров

Мы предлагаем:

- Конкурентоспособные цены и скидки постоянным клиентам.
- Специальные условия для постоянных клиентов.
- Подбор аналогов.
- Поставку компонентов в любых объемах, удовлетворяющих вашим потребностям.
- Приемлемые сроки поставки, возможна ускоренная поставка.
- Доставку товара в любую точку России и стран СНГ.
- Комплексную поставку.
- Работу по проектам и поставку образцов.
- Формирование склада под заказчика.
- Сертификаты соответствия на поставляемую продукцию (по желанию клиента).
- Тестирование поставляемой продукции.
- Поставку компонентов, требующих военную и космическую приемку.
- Входной контроль качества.
- Наличие сертификата ISO.

В составе нашей компании организован Конструкторский отдел, призванный помогать разработчикам, и инженерам.

Конструкторский отдел помогает осуществить:

- Регистрацию проекта у производителя компонентов.
- Техническую поддержку проекта.
- Защиту от снятия компонента с производства.
- Оценку стоимости проекта по компонентам.
- Изготовление тестовой платы монтаж и пусконаладочные работы.



Тел: +7 (812) 336 43 04 (многоканальный)

Email: org@lifeelectronics.ru