



Is Now Part of



ON Semiconductor®

To learn more about ON Semiconductor, please visit our website at
www.onsemi.com

Please note: As part of the Fairchild Semiconductor integration, some of the Fairchild orderable part numbers will need to change in order to meet ON Semiconductor's system requirements. Since the ON Semiconductor product management systems do not have the ability to manage part nomenclature that utilizes an underscore (_), the underscore (_) in the Fairchild part numbers will be changed to a dash (-). This document may contain device numbers with an underscore (_). Please check the ON Semiconductor website to verify the updated device numbers. The most current and up-to-date ordering information can be found at www.onsemi.com. Please email any questions regarding the system integration to Fairchild_questions@onsemi.com.

ON Semiconductor and the ON Semiconductor logo are trademarks of Semiconductor Components Industries, LLC dba ON Semiconductor or its subsidiaries in the United States and/or other countries. ON Semiconductor owns the rights to a number of patents, trademarks, copyrights, trade secrets, and other intellectual property. A listing of ON Semiconductor's product/patent coverage may be accessed at www.onsemi.com/site/pdf/Patent-Marking.pdf. ON Semiconductor reserves the right to make changes without further notice to any products herein. ON Semiconductor makes no warranty, representation or guarantee regarding the suitability of its products for any particular purpose, nor does ON Semiconductor assume any liability arising out of the application or use of any product or circuit, and specifically disclaims any and all liability, including without limitation special, consequential or incidental damages. Buyer is responsible for its products and applications using ON Semiconductor products, including compliance with all laws, regulations and safety requirements or standards, regardless of any support or applications information provided by ON Semiconductor. "Typical" parameters which may be provided in ON Semiconductor data sheets and/or specifications can and do vary in different applications and actual performance may vary over time. All operating parameters, including "Typicals" must be validated for each customer application by customer's technical experts. ON Semiconductor does not convey any license under its patent rights nor the rights of others. ON Semiconductor products are not designed, intended, or authorized for use as a critical component in life support systems or any FDA Class 3 medical devices or medical devices with a same or similar classification in a foreign jurisdiction or any devices intended for implantation in the human body. Should Buyer purchase or use ON Semiconductor products for any such unintended or unauthorized application, Buyer shall indemnify and hold ON Semiconductor and its officers, employees, subsidiaries, affiliates, and distributors harmless against all claims, costs, damages, and expenses, and reasonable attorney fees arising out of, directly or indirectly, any claim of personal injury or death associated with such unintended or unauthorized use, even if such claim alleges that ON Semiconductor was negligent regarding the design or manufacture of the part. ON Semiconductor is an Equal Opportunity/Affirmative Action Employer. This literature is subject to all applicable copyright laws and is not for resale in any manner.



September 2014



FOD8332 — Input LED Drive, 2.5 A Output Current, IGBT Drive Optocoupler with Desaturation Detection, Isolated Fault Sensing, and Active Miller Clamp

FOD8332

Input LED Drive, 2.5 A Output Current, IGBT Drive Optocoupler with Desaturation Detection, Isolated Fault Sensing, and Active Miller Clamp

Features

- Input LED Drive Facilitates Receiving Digitally Encoded Signals from PWM Output
- Optically Isolated Fault-Sensing Feedback
- Active Miller Clamp to Shut Off IGBT During High dv/dt without Negative Supply Voltage
- High Noise Immunity Characterized by Common Mode Rejection – 35 kV/ μ s Minimum, $V_{CM} = 1500 V_{PEAK}$
- 2.5 A Peak Output Current Driving Capability for Medium Power IGBT
 - P-Channel MOSFETs at Output Stage Enable Output Voltage Swing Close to Supply Rail (Rail-to-Rail Output)
 - Wide Supply Voltage Range: 15 V to 30 V
- Integrated IGBT Protection
 - Desaturation Detection
 - “Soft” IGBT Turn-Off
 - Under-Voltage Lockout (UVLO) with Hysteresis
- Fast Switching Speed Over Full Operating Temperature Range
 - 250 ns Maximum Propagation Delay
 - 100 ns Maximum Pulse Width Distortion
- Extended Industrial Temperature Range:
 - -40°C to 100°C
- Safety and Regulatory Approvals
 - UL1577, 4,243 V_{RMS} for 1 Minute
 - DIN-EN/IEC60747-5-5:
 - 1,414 V_{PEAK} Working Insulation Voltage Rating
 - 8,000 V_{PEAK} Transient Isolation Voltage Rating
- 8 mm Creepage and Clearance Distances

Applications

- AC and Brushless DC Motor Drive
- Industrial Inverter
- Uninterruptible Power Supply
- Induction Heating
- Isolated IGBT/Power MOSFET Gate Drive

Description

The FOD8332 is an advanced 2.5 A output current IGBT drive optocoupler capable of driving medium-power IGBTs with ratings up to 1,200 V and 150 A. It is suited for fast-switching driving of power IGBTs and MOSFETs in motor-control inverter applications and high-performance power systems. The FOD8332 offers protection features necessary for preventing fault conditions that lead to destructive thermal runaway of IGBTs.

The device utilizes Fairchild’s proprietary Optoplanar[®] coplanar packaging technology and optimized IC design to achieve reliable high isolation and high noise immunity, characterized by high common-mode rejection and power supply rejection specifications. The device is housed in a wide-body, 16-pin, small-outline, plastic package.

The gate-driver channel consists of an aluminum gallium arsenide (AlGaAs) light-emitting diode (LED) optically coupled to an integrated high-speed driver circuit with a low- $R_{DS(ON)}$ MOSFET output stage. The fault-sense channel consists of an AlGaAs LED optically coupled to an integrated high-speed feedback circuit for fault sensing.

Related Resources

- [FOD8316—2.5 A Output Current, IGBT Drive Optocoupler with Desaturation, Isolated Fault Sensing](#)
- [FOD8318—2.5 A Output Current, IGBT Drive Optocoupler with Active Miller Clamp, Desaturation Detection, and Isolated Fault Sensing](#)
- [FOD8333 – Input LED Drive, 2.5 A Output Current, IGBT Drive Optocoupler with Desaturation Detection, Isolated Fault Sensing, Active Miller Clamp, and Automatic Fault Reset](#)
- [AN-3009—Standard Gate-Driver Optocouplers](#)
- www.fairchildsemi.com/search/tree/optoelectronics/

Truth Table

LED	UVLO ($V_{DD} - V_E$)	DESAT Detected?	FAULT ⁽¹⁾	V_O
X	Active	X	HIGH	LOW
On	Not Active	Yes	LOW	LOW
Off	X	X	HIGH	LOW
On	Not Active	No	HIGH	HIGH

Note:

1. FAULT pin is connected to a pull-up resistor.

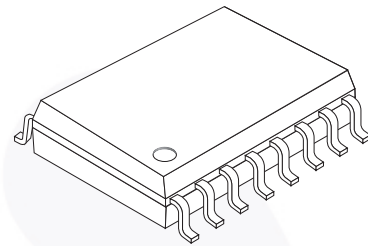
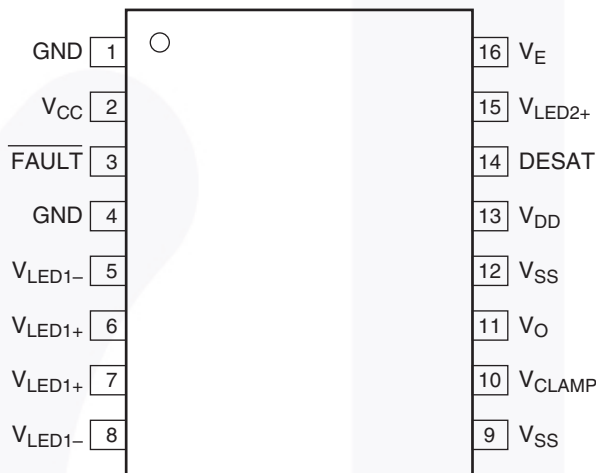

Figure 2. Pin Configuration

Pin Definitions

Pin #	Name	Description
1	GND	Ground for Fault-Sense Optocoupler
2	V_{CC}	Positive Supply Voltage (3 V to 15 V) for Fault Sense Optocoupler
3	FAULT	Fault-Sense Output
4	GND	Ground for Fault-Sense Optocoupler
5	V_{LED1-}	LED1 Cathode
6	V_{LED1+}	LED1 Anode
7	V_{LED1+}	LED1 Anode
8	V_{LED1-}	LED1 Cathode
9	V_{SS}	Negative Output Supply Voltage
10	V_{CLAMP}	Clamp Supply Voltage
11	V_O	Gate-Drive Output Voltage
12	V_{SS}	Negative Output Supply Voltage
13	V_{DD}	Positive Output Supply Voltage
14	DESAT	Desaturation Voltage Input
15	V_{LED2+}	LED2 Anode (Do not connect. Leave floating.)
16	V_E	Output Supply Voltage/IGBT Emitter

Block Diagram

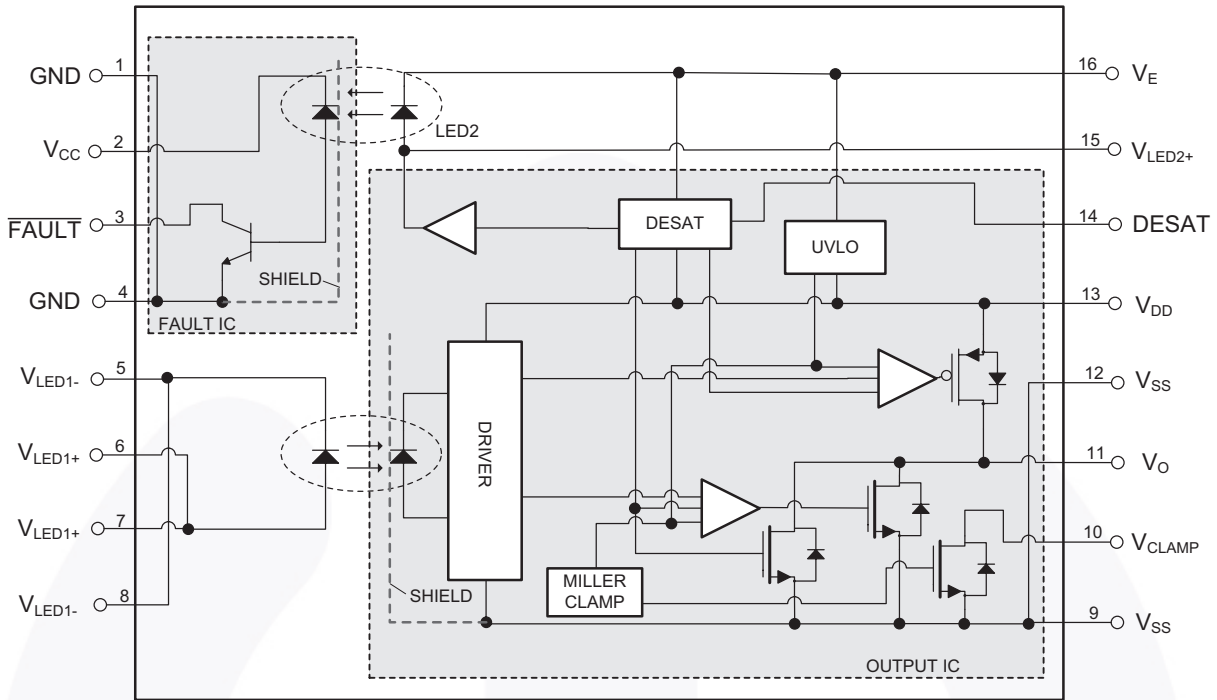

Figure 3. Functional Block Diagram

Safety and Insulation Ratings

As per DIN EN/IEC 60747-5-5, this optocoupler is suitable for “safe electrical insulation” only within the safety limit data. Compliance with the safety ratings must be ensured by means of protective circuits.

Symbol	Parameter	Min.	Typ.	Max.	Unit
	Installation Classifications per DIN VDE 0110/1.89 Table 1				
	Rated Mains Voltage < 150 V _{RMS}		I–IV		
	Rated Mains Voltage < 300 V _{RMS}		I–IV		
	Rated Mains Voltage < 450 V _{RMS}		I–IV		
	Rated Mains Voltage < 600 V _{RMS}		I–IV		
	Rated Mains Voltage < 1000 V _{RMS}		I–III		
	Climatic Classification		40/100/21		
	Pollution Degree (DIN VDE 0110/1.89)		2		
CTI	Comparative Tracking Index (DIN IEC 112/VDE 0303 Part 1)	175			
V _{PR}	Input-to-Output Test Voltage, Method b, V _{IORM} × 1.875 = V _{PR} , 100% Production Test with t _m = 1 s, Partial Discharge < 5 pC	2651			V _{peak}
	Input-to-Output Test Voltage, Method a, V _{IORM} × 1.6 = V _{PR} , Type and Sample Test with t _m = 10 s, Partial Discharge < 5 pC	2262			V _{peak}
V _{IORM}	Maximum Working Insulation Voltage	1414			V _{peak}
V _{IOTM}	Highest Allowable Over Voltage	8000			V _{peak}
	External Creepage	8.0			mm
	External Clearance	8.0			mm
	Insulation Thickness	0.5			mm
T _{Case}	Safety Limit Values – Maximum Values in Failure; Case Temperature	150			°C
P _{S,INPUT}	Safety Limit Values – Maximum Values in Failure; Input Power	100			mW
P _{S,OUTPUT}	Safety Limit Values – Maximum Values in Failure; Output Power	600			mW
R _{IO}	Insulation Resistance at T _S , V _{IO} = 500 V	10 ⁹			Ω

Absolute Maximum Ratings

Stresses exceeding the absolute maximum ratings may damage the device. The device may not function or be operable above the recommended operating conditions and stressing the parts to these levels is not recommended. In addition, extended exposure to stresses above the recommended operating conditions may affect device reliability. The absolute maximum ratings are stress ratings only. $T_A = 25^\circ\text{C}$ unless otherwise specified.

Symbol	Parameter	Value	Units
T_{STG}	Storage Temperature	-40 to +125	$^\circ\text{C}$
T_{OPR}	Operating Temperature	-40 to +100	$^\circ\text{C}$
T_J	Junction Temperature	-40 to +125	$^\circ\text{C}$
T_{SOL}	Lead Solder Temperature (not certified for wave immersion) <i>Refer to reflow temperature profile on page 31</i>	260 for 10 s	$^\circ\text{C}$
PD_I	Input Power Dissipation ⁽²⁾⁽³⁾	45	mW
PD_O	Output Power Dissipation ⁽³⁾⁽⁴⁾	600	mW
Gate Drive Channel			
$I_{F(AVG)}$	Average Input Current	25	mA
$I_{F(PEAK)}$	Peak Transient Forward Current (Pulse Width < 1 μs)	1.0	A
$I_{OH(PEAK)}$	Peak Output High Current ⁽⁵⁾	3.0	A
$I_{OL(PEAK)}$	Peak Output Low Current ⁽⁵⁾	3.0	A
V_R	Reverse Input Voltage	5.0	V
$V_E - V_{SS}$	Negative Output Supply Voltage ⁽⁶⁾	-0.5 to 15	V
$V_{DD} - V_E$	Positive Output Supply Voltage	-0.5 to 35 - ($V_E - V_{SS}$)	V
$V_{O(PEAK)} - V_{SS}$	Gate Drive Output Voltage	-0.5 to 35	V
$V_{DD} - V_{SS}$	Output Supply Voltage	-0.5 to 35	V
V_{DESAT}	Desaturation Voltage	V_E to $V_E + 25$	V
I_{DESAT}	Desaturation Current	60	mA
$V_{CLAMP} - V_{SS}$	Active Miller Clamping Voltage	-0.5 to 35	V
I_{CLAMP}	Peaking Clamping Sinking Current	1.7	A
$t_{R(IN)}, t_{F(IN)}$	Input Signal Rise and Fall Time	500	ns
Fault Sense Channel			
V_{CC}	Positive Input Supply Voltage	-0.5 to 20	V
$V_{\overline{FAULT}}$	\overline{FAULT} Output Voltage	-0.5 to 20	V
$I_{\overline{FAULT}}$	\overline{FAULT} Output Current	16.0	mA

Notes:

- No derating required across temperature range.
- Functional operation under these conditions is not implied. Permanent damage may occur if the device is subjected to conditions outside these ratings.
- Derate linearly above 25°C , free air temperature at a rate of $6.2 \text{ mW}/^\circ\text{C}$.
- Maximum pulse width = 10 μs .
- This negative output supply voltage is optional. It is only needed when negative gate drive is implemented.

Recommended Operating Conditions

The Recommended Operating Conditions table defines the conditions for actual device operation. Recommended operating conditions are specified to ensure optimal performance to the datasheet specifications. Fairchild does not recommend exceeding them or designing to absolute maximum ratings.

Symbol	Parameter	Min.	Max.	Unit
T_A	Ambient Operating Temperature	-40	+100	°C
$I_{F(ON)}$	Input Current (ON)	7	16	mA
$V_{F(OFF)}$	Input Voltage (OFF)	-3.6	0.8	V
V_{CC}	Supply Voltage	3	15	V
$V_{DD} - V_{SS}$	Total Output Supply Voltage	15	30	V
$V_{DD} - V_E$	Positive Output Supply Voltage ⁽⁷⁾	15	$30 - (V_E - V_{SS})$	V
$V_E - V_{SS}$	Negative Output Supply Voltage	0	15	V
t_{PW}	Input Pulse Width	500		ns

Note:

7. During power up or down, ensure that both the input and output supply voltages reach the proper recommended operating voltages to avoid any momentary instability at the output state.

Isolation Characteristics

Apply over all recommended conditions; typical value is measured at $T_A = 25^\circ\text{C}$.

Symbol	Parameter	Conditions	Min.	Typ.	Max.	Units
V_{ISO}	Input-Output Isolation Voltage	$T_A = 25^\circ\text{C}$, Relative Humidity < 50%, $t = 1.0$ minute, $I_{I-O} \leq 10 \mu\text{A}$, 50 Hz ⁽⁸⁾⁽⁹⁾⁽¹⁰⁾	4,243			V_{RMS}
R_{ISO}	Isolation Resistance	$V_{I-O} = 500 \text{ V}^{(8)}$		10^{11}		
C_{ISO}	Isolation Capacitance	$V_{I-O} = 0 \text{ V}$, Frequency = 1.0 MHz ⁽⁸⁾		1		pF

Notes:

8. Device is considered a two-terminal device: pins 1 to 8 are shorted together and pins 9 to 16 are shorted together.
9. 4,243 V_{RMS} for 1-minute duration is equivalent to 5,091 V_{RMS} for 1-second duration.
10. The input-output isolation voltage is a dielectric voltage rating per UL1577. It should not be regarded as an input-output continuous voltage rating. For the continuous working voltage rating, refer to equipment-level safety specification or DIN EN/IEC 60747-5-5 Safety and Insulation Ratings Table on page 4.

Electrical Characteristics

Apply over all recommended conditions; typical value is measured at $V_{CC} = 5\text{ V}$, $V_{DD} - V_{SS} = 30\text{ V}$, $V_E - V_{SS} = 0\text{ V}$, and $T_A = 25^\circ\text{C}$; unless otherwise specified.

Symbol	Parameter	Conditions	Min.	Typ.	Max.	Units	Figure
Gate Drive Channel							
V_F	Input Forward Voltage	$I_F = 10\text{ mA}$	1.10	1.45	1.80	V	5
$\Delta(V_F/T_A)$	Temperature Coefficient of Forward Voltage			-1.5		mV/°C	
BV_R	Input Reverse Breakdown Voltage	$I_R = 10\text{ }\mu\text{A}$	5			V	
C_{IN}	Input Capacitance	$f = 1\text{ MHz}$, $V_F = 0\text{ V}$		60		pF	
I_{FLH}	Threshold Input Current, Low-to-High	$I_O = 0\text{ mA}$, $V_O > 5\text{ V}$		2.5	7.0	mA	30
V_{FHL}	Threshold Input Voltage, High-to-Low	$I_O = 0\text{ mA}$, $V_O < 5\text{ V}$	0.8			V	31
I_{OH}	High Level Output Current	$V_O = V_{DD} - 3\text{ V}$, $I_F = 10\text{ mA}$	-1.0	-2.5		A	6, 10, 32
		$V_O = V_{DD} - 6\text{ V}$, $I_F = 10\text{ mA}^{(11)}$	-2.5			A	
I_{OL}	Low Level Output Current	$V_O = V_{SS} + 3\text{ V}$, $I_F = 0\text{ mA}$	1	3		A	7, 11, 33
		$V_O = V_{SS} + 6\text{ V}$, $I_F = 0\text{ mA}^{(12)}$	2.5			A	
I_{OLF}	Low Level Output Current During Fault Condition	$V_O - V_{SS} = 14\text{ V}$	70	125	170	mA	34
V_{OH}	High Level Output Voltage	$I_F = 10\text{ mA}$, $I_O = -100\text{ mA}^{(13)(14)(15)}$	$V_{DD} - 1.0$	$V_{DD} - 0.2$		V	8, 10, 35
V_{OL}	Low Level Output Voltage	$I_F = 0\text{ mA}$, $I_O = 100\text{ mA}$		0.1	0.5	V	9, 11, 36
I_{DDH}	High Level Supply Current	$V_O = \text{Open}^{(15)}$, $I_O = 0\text{ mA}$		2.5	5.0	mA	12, 13, 37
I_{DDL}	Low Level Supply Current	$V_O = \text{Open}$, $I_O = 0\text{ mA}$		2.5	5.0	mA	12, 13, 38
I_{EL}	V_E Low Level Supply Current		-0.8	-0.5		mA	38
I_{EH}	V_E High Level Supply Current		-0.50	-0.25		mA	37
I_{CHG}	Blanking Capacitor Charge Current	$V_{DESAT} = 2\text{ V}^{(15)(16)}$	-0.33	-0.25	-0.13	mA	14, 39
I_{DSCHG}	Blanking Capacitor Discharge Current	$V_{DESAT} = 7\text{ V}$	10	40		mA	39
V_{UVLO+}	Under-Voltage Lockout Threshold ⁽¹⁴⁾	$I_F = 10\text{ mA}$, $V_O > 5\text{ V}$	10.8	11.7	12.7	V	40
V_{UVLO-}		$I_F = 10\text{ mA}$, $V_O < 5\text{ V}$	9.8	10.7	11.7	V	
$UVLO_{HYS}$	Under-Voltage Lockout Threshold Hysteresis			1.0		V	
V_{DESAT}	DESAT Threshold ⁽¹⁴⁾	$V_{DD} - V_E > V_{ULVO-}$	6.0	6.5	7.2	V	15, 39
V_{CLAMP_THRES}	Clamping Threshold Voltage			2.0		V	41
I_{CLAMPL}	Clamp Low Level Sinking Current	$V_O = V_{SS} + 2.5\text{ V}$	0.35	1.10		A	16, 42

Electrical Characteristics (Continued)

Apply over all recommended conditions; typical value is measured at $V_{CC} = 5\text{ V}$, $V_{DD} - V_{SS} = 30\text{ V}$, $V_E - V_{SS} = 0\text{ V}$, and $T_A = 25^\circ\text{C}$; unless otherwise specified.

Symbol	Parameter	Conditions	Min.	Typ.	Max.	Units	Figure
Fault Feedback Channel							
I_{CCH}	$\overline{\text{FAULT}}$ High Level Supply Current	$I_{F2} = 0\text{ mA}$, $V_{\overline{\text{FAULT}}} = \text{Open}$, $V_{CC} = 15\text{ V}$		0.0004	2	μA	43
I_{CCL}	$\overline{\text{FAULT}}$ Low Level Supply Current	$I_{F2} = 16\text{ mA}$, $V_{\overline{\text{FAULT}}} = \text{Open}$, $V_{CC} = 15\text{ V}$		150	200	μA	44
$I_{\overline{\text{FAULTH}}}$	$\overline{\text{FAULT}}$ Logic High Output Current	$V_{\overline{\text{FAULT}}} = V_{CC} = 5.5\text{ V}$		0.02	0.50	μA	45
$I_{\overline{\text{FAULTL}}}$	$\overline{\text{FAULT}}$ Logic Low Output Current	$V_{\overline{\text{FAULT}}} = 0.4\text{ V}$, $V_{CC} = 5.5\text{ V}$	1.1			mA	17, 46

Notes:

11. Maximum pulse width = 10 μs , maximum duty cycle = 0.2%.
12. Minimum pulse width = 4.99 ms, minimum duty cycle = 99.8%.
13. V_{OH} is measured with the DC load current in this testing (maximum pulse width = 1 ms, maximum duty cycle = 20%). When driving capacitive loads, V_{OH} approaches V_{DD} as I_{OH} approaches zero units.
14. Positive output supply voltage ($V_{DD} - V_E$) should be at least 15 V to ensure adequate margin in excess of the maximum under-voltage lockout threshold, V_{UVLO+} , of 12.7 V.
15. When $V_{DD} - V_E > V_{UVLO}$ and the output state V_O is allowed to go HIGH, the DESAT-detection feature is active and provides the primary source of IGBT protection. UVLO is needed to ensure DESAT detection is functional.
16. The blanking time, t_{BLANK} , is adjustable by an external capacitor (C_{BLANK}), where $t_{BLANK} = C_{BLANK} \times (V_{DESAT} / I_{CHG})$.

Switching Characteristics

Apply over all recommended conditions; typical value is measured at $V_{CC} = 5\text{ V}$, $V_{DD} - V_{SS} = 30\text{ V}$, $V_E - V_{SS} = 0\text{ V}$, and $T_A = 25^\circ\text{C}$; unless otherwise specified.

Symbol	Parameter	Conditions	Min.	Typ.	Max.	Units	Figure
t_{PHL}	Propagation Delay to Logic Low Output ⁽¹⁸⁾	Rg = 10 Ω , Cg = 10 nF, f = 10 kHz, Duty Cycle = 50%, I _F = 10 mA, V _{DD} - V _{SS} = 30 V ⁽¹⁷⁾	100	135	250	ns	18, 19, 20, 21, 47
t_{PLH}	Propagation Delay to Logic High Output ⁽¹⁹⁾		100	150	250	ns	
PWD	Pulse Width Distortion, $t_{PHL} - t_{PLH}$ ⁽²⁰⁾				15	100	ns
PDD Skew	Propagation Delay Difference Between Any Two Parts or Channels, ($t_{PHL} - t_{PLH}$) ⁽²¹⁾		-150		150	ns	
t_R	Output Rise Time (10% to 90%)			50		ns	47
t_F	Output Fall Time (90% to 10%)			50		ns	
$t_{DESAT(LOW)}$	DESAT Sense to DESAT Low Propagation Delay ⁽²⁴⁾			0.25		μs	
$t_{DESAT(90\%)}$	DESAT Sense to 90% V _O Delay ⁽²²⁾			0.45	0.70	μs	22, 48
$t_{DESAT(10\%)}$	DESAT Sense to 10% V _O Delay ⁽²²⁾	Rg = 10 Ω , Cg = 10 nF, V _{DD} - V _{SS} = 30 V (C _{DESAT} = 100pF, R _F = 4.7 k Ω , V _{CC} = 5.5 V)		2.8	4.0	μs	23, 24, 25, 48
$t_{DESAT(FAULT)}$	DESAT Sense to Low Level FAULT Signal Delay ⁽²³⁾			0.5	1.5	μs	26, 48
$t_{RESET(FAULT)}$	RESET to High Level FAULT Signal Delay ⁽²⁵⁾		0.5	2.3	4.5	μs	27, 48
$t_{DESAT(MUTE)}$	DESAT Input Mute		10.0	22.0	35.0	μs	48
$t_{UVLO\ ON}$	UVLO Turn-On Delay ⁽²⁶⁾	V _{DD} = 20 V in 1.0 ms Ramp		4.0		μs	49
$t_{UVLO\ OFF}$	UVLO Turn-Off Delay ⁽²⁷⁾			4.0		μs	
t_{GP}	Time-to-Good Power ⁽²⁸⁾	V _{DD} = 0 to 30 V in 10 μs Ramp		2.0		μs	28, 29, 49
CM _H	Common Mode Transient Immunity at Output High	T _A = 25°C, V _{CC} = 5 V, V _{DD} = 25 V, V _{SS} = Ground, C _F = 15 pF, R _F = 4.7 k Ω , V _{CM} = 1500 V _{PEAK} ⁽²⁹⁾	35	50		kV/ μs	51, 52
CM _L	Common Mode Transient Immunity at Output Low	T _A = 25°C, V _{CC} = 5 V, V _{DD} = 25 V, V _{SS} = Ground, C _F = 15 pF, R _F = 4.7 k Ω , V _{CM} = 1500 V _{PEAK} ⁽³⁰⁾	35	50		kV/ μs	50, 53

Notes:

17. This load condition approximates the gate load of a 1200 V / 150 A IGBT.
18. Propagation delay t_{PHL} is measured from the 50% level on the falling edge of the input pulse to the 50% level of the falling edge of the V_O signal.
19. Propagation delay t_{PLH} is measured from the 50% level on the rising edge of the input pulse to the 50% level of the rising edge of the V_O signal.
20. PWD is defined as | $t_{PHL} - t_{PLH}$ | for any given device.
21. The difference between t_{PHL} and t_{PLH} between any two parts under same operating conditions with equal loads.
22. The length of time the DESAT threshold must be exceeded before V_O begins to go LOW. This is supply voltage dependent.

23. The time from DESAT threshold is exceeded until the FAULT output goes LOW.
24. The length of time the DESAT threshold must be exceeded before V_O begins to go LOW and the FAULT output begins to go LOW.
25. The length of time from when RESET is initiated (via I_F turn-on) until FAULT output goes HIGH.
26. The UVLO turn-on delay, $t_{UVLO\ ON}$, is measured from the V_{UVLO+} threshold level of the rising edge of the output supply voltage (V_{DD}) to the 5 V level of the rising edge of the V_O signal.
27. The UVLO turn-off delay, $t_{UVLO\ OFF}$, is measured from the V_{UVLO-} threshold level of the falling edge of the output supply voltage (V_{DD}) to the 5 V level of the falling edge of the V_O signal.
28. The time to good power, t_{GP} , is measured from the V_{UVLO+} threshold level of the rising edge of the output supply voltage (V_{DD}) to the 5 V level of the rising edge of the V_O signal.
29. Common-mode transient immunity at output HIGH state is the maximum tolerable negative dV_{CM}/dt on the trailing edge of the common-mode pulse, V_{CM} , to assure the output remains in HIGH state (i.e., $V_O > 15\text{ V}$ or $V_{FAULT} > 2\text{ V}$).
30. Common-mode transient immunity at output LOW state is the maximum positive tolerable dV_{CM}/dt on the leading edge of the common-mode pulse, V_{CM} , to ensure the output remains in LOW state (i.e., $V_O < 1.0\text{ V}$ or $V_{FAULT} < 0.8\text{ V}$).

Timing Diagrams

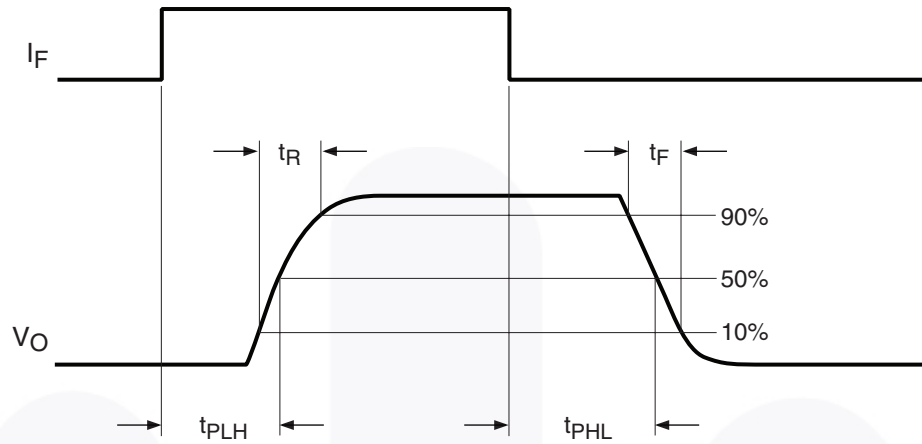

Figure 3. t_{PLH} , t_{PHL} , t_R , and t_F Timing Diagram

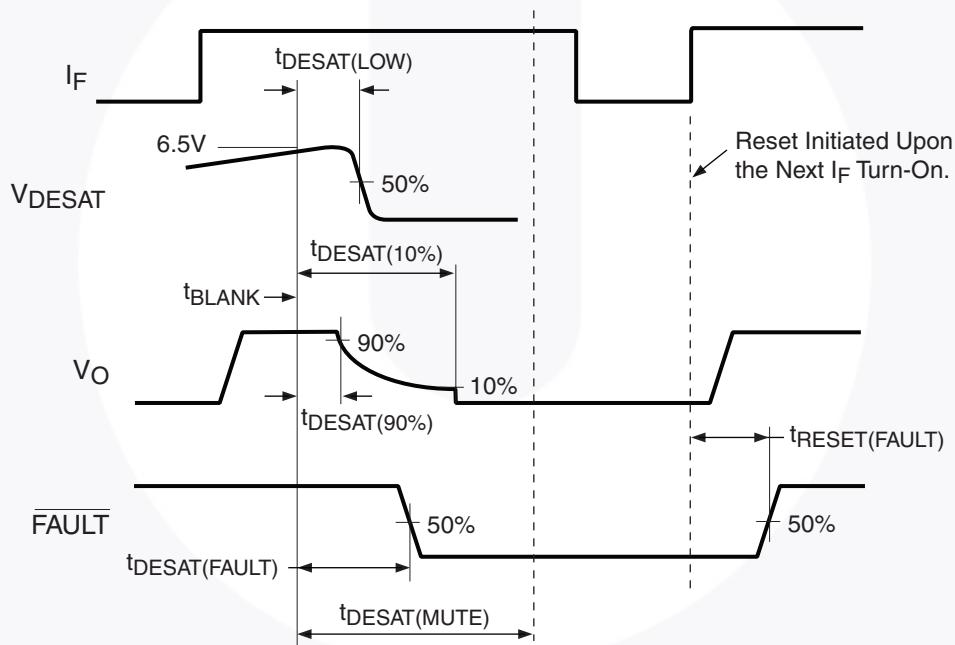

Figure 4. Definitions for DESAT, V_O and $\overline{\text{FAULT}}$ Timing Waveforms

Typical Performance Characteristics

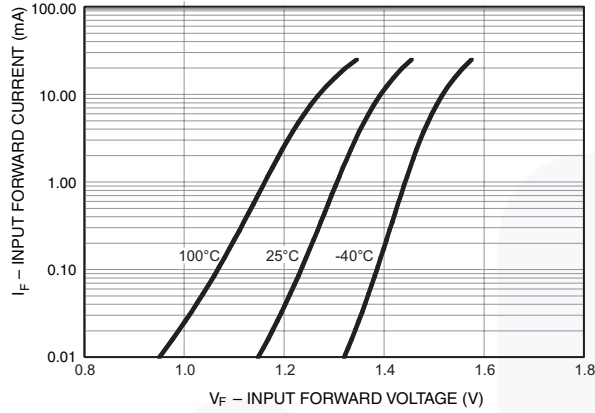

Figure 5. Input Forward Current (I_F) vs. Voltage (V_F)

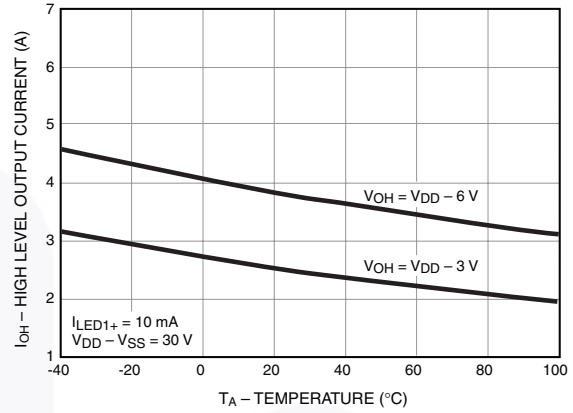

Figure 6. High Level Output Current (I_{OH}) vs. Temperature

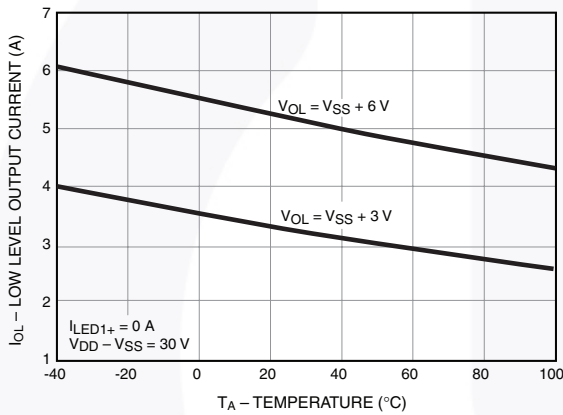

Figure 7. Low Level Output Current (I_{OL}) vs. Temperature

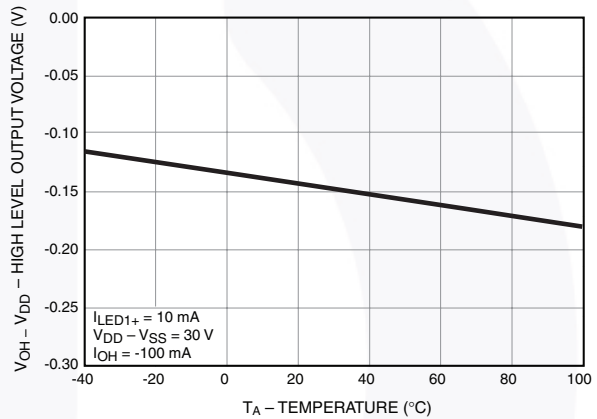

Figure 8. High Level Output Voltage ($V_{OH} - V_{DD}$) vs. Temperature

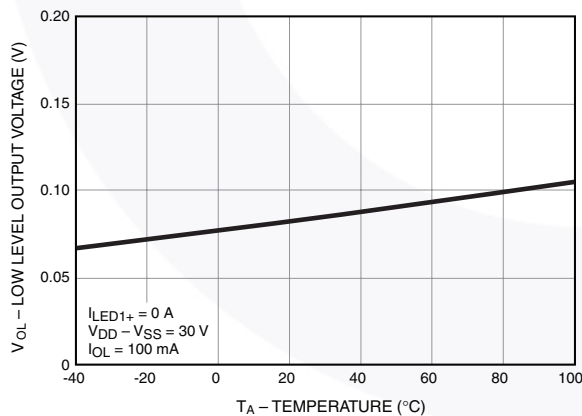

Figure 9. Low Level Output Voltage (V_{OL}) vs. Temperature

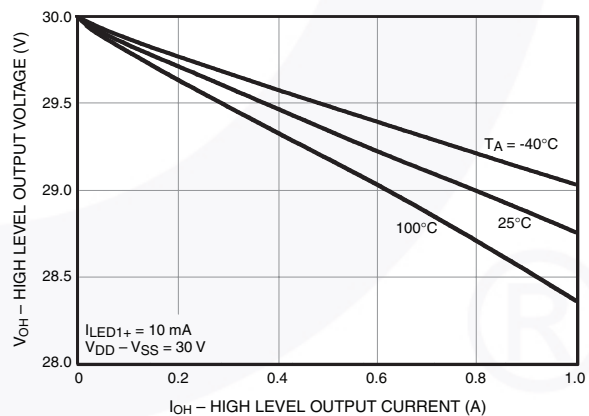

Figure 10. High Level Output Voltage (V_{OH}) vs. High Level Output Current (I_{OH})

Typical Performance Characteristics (Continued)

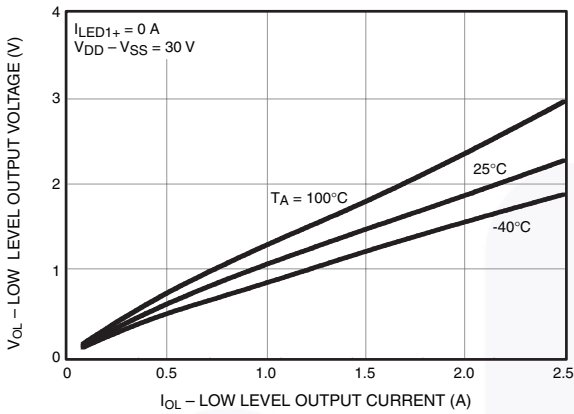

Figure 11. Low Level Output Voltage (V_{OL}) vs. Low Level Output Current (I_{OL})

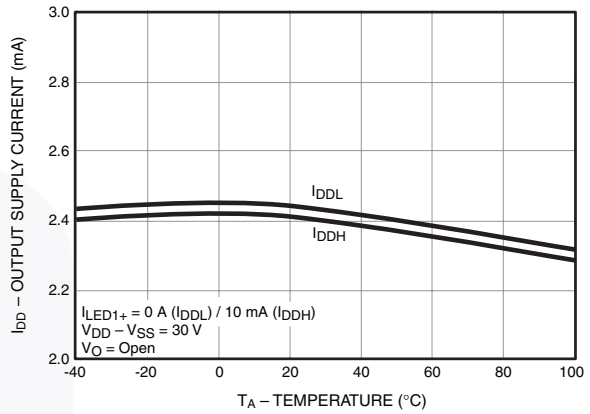

Figure 12. Output Supply Current (I_{DD}) vs. Temperature

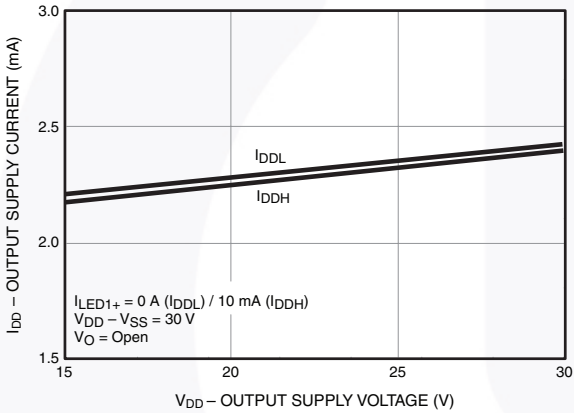

Figure 13. Output Supply Current (I_{DD}) vs. Voltage (V_{DD})

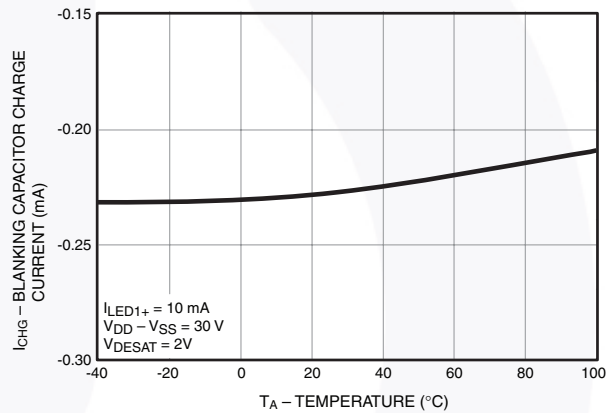

Figure 14. Blanking Capacitor Charge Current (I_{CHG}) vs. Temperature

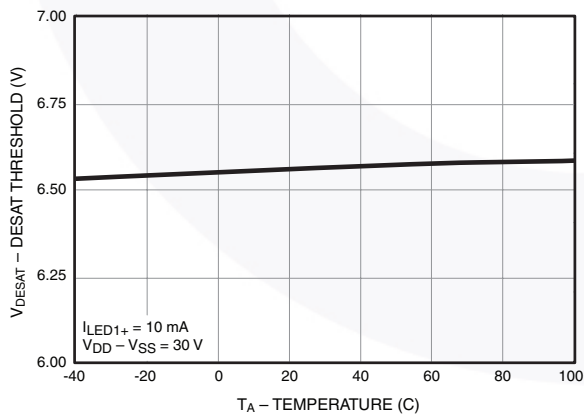

Figure 15. DESAT Threshold (V_{DESAT}) vs. Temperature

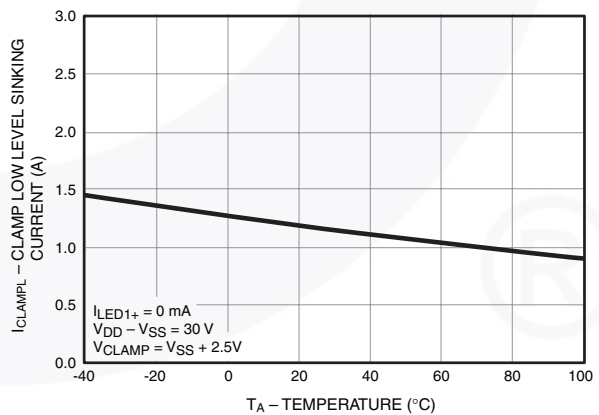

Figure 16. Clamp Low Level Sinking Current (I_{CLAMPL}) vs. Temperature

Typical Performance Characteristics (Continued)

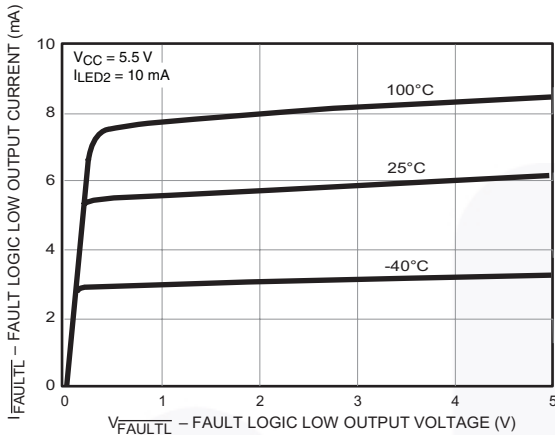

Figure 17. FAULT Logic Low Output Current (I_{FAULTL}) vs. Voltage (V_{FAULTL})

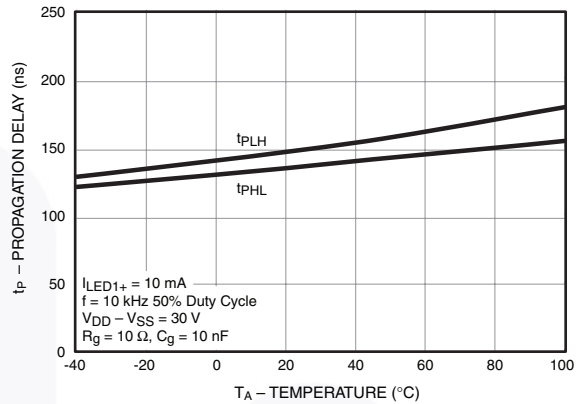

Figure 18. Propagation Delay (t_p) vs. Temperature

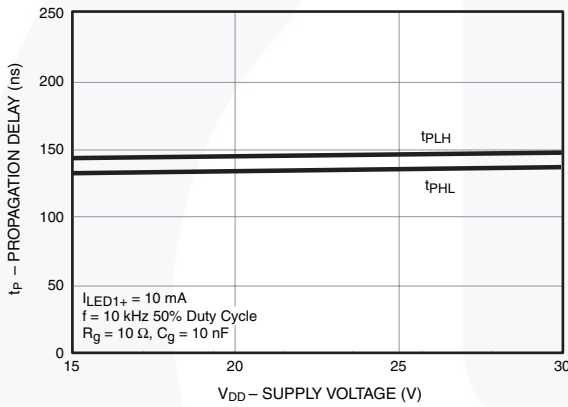

Figure 19. Propagation Delay (t_p) vs. Supply Voltage (V_{DD})

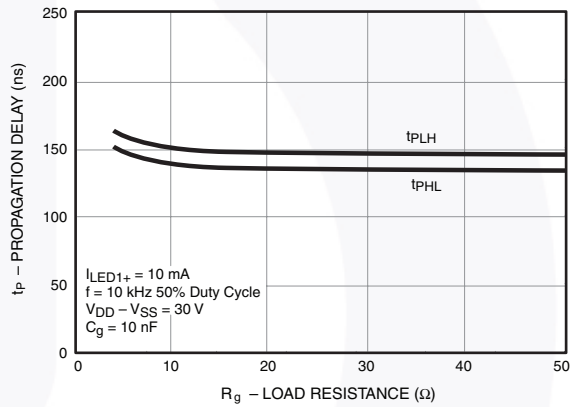

Figure 20. Propagation Delay (t_p) vs. Load Resistance (R_g)

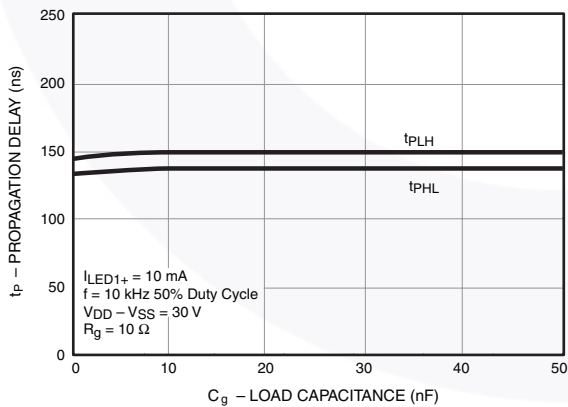

Figure 21. Propagation Delay (t_p) vs. Load Capacitance (C_g)

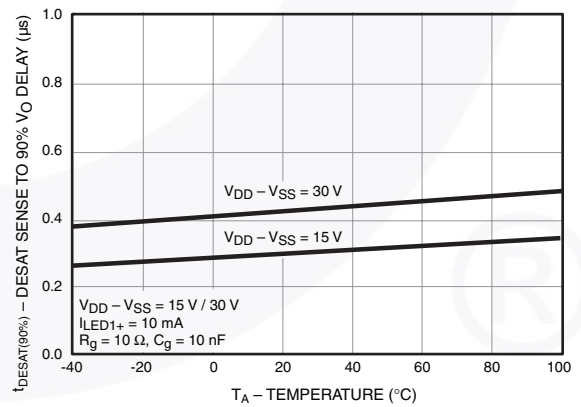

Figure 22. DESAT Sense to 90% V_O Delay ($t_{DESAT(90\%)}$) vs. Temperature

Typical Performance Characteristics (Continued)

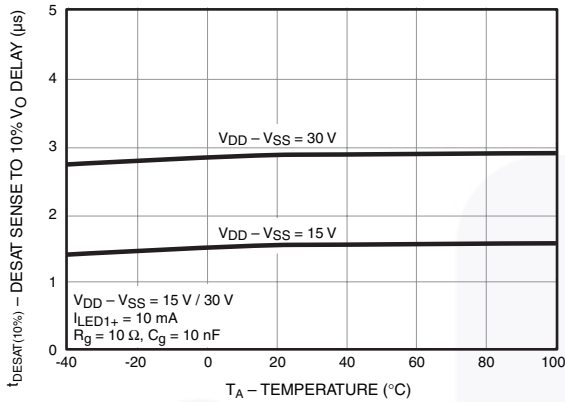

Figure 23. DESAT Sense to 10% V_O Delay ($t_{DESAT(10\%)}$) vs. Temperature

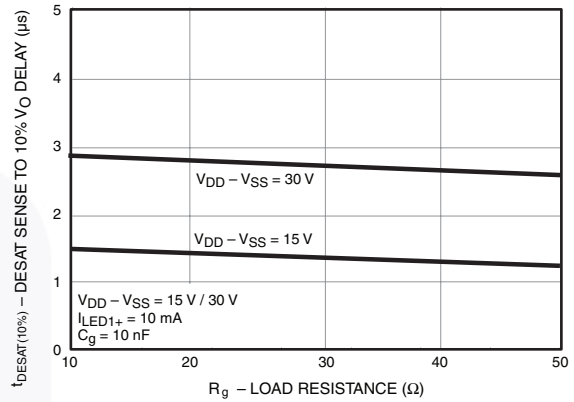

Figure 24. DESAT Sense to 10% V_O Delay ($t_{DESAT(10\%)}$) vs. Load Resistance (R_g)

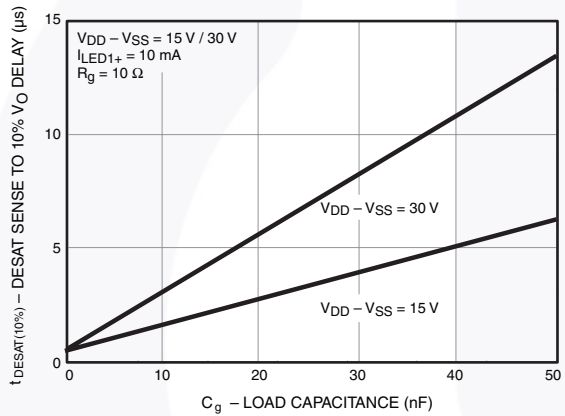

Figure 25. DESAT Sense to 10% V_O Delay ($t_{DESAT(10\%)}$) vs. Load Capacitance (C_g)

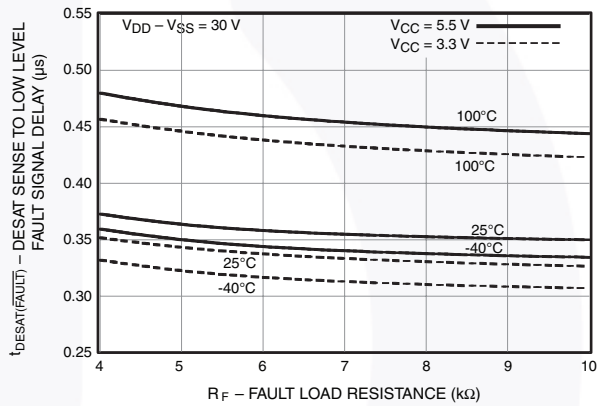

Figure 26. DESAT Sense to Low Level Fault Signal Delay ($t_{DESAT(FAULT)}$) vs. Fault Load Resistance (R_F)

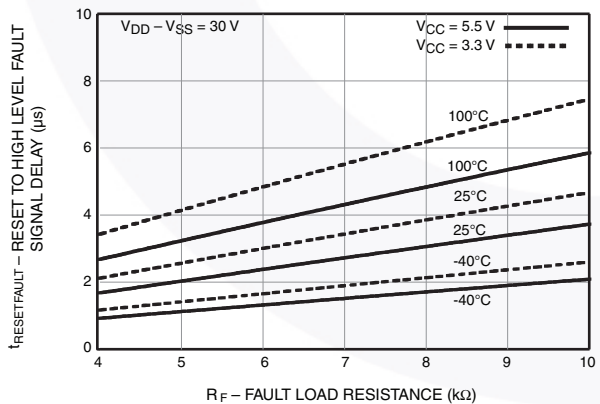

Figure 27. RESET to High Level Fault Signal Delay ($t_{RESET(FAULT)}$) vs. Fault Load Resistance (R_F)

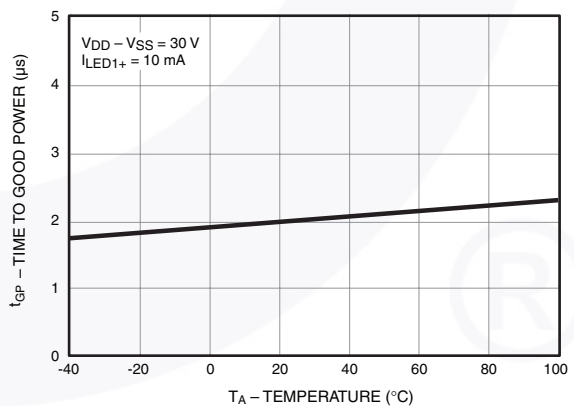

Figure 28. Time-to-Good Power (t_{GP}) vs. Temperature

Typical Performance Characteristics (Continued)

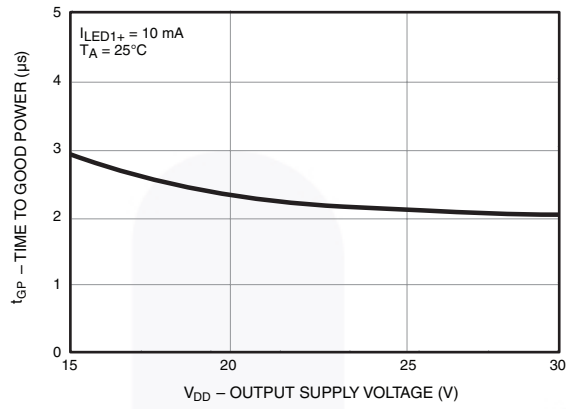

Figure 29. Time-to-Good Power (t_{GP}) vs. Output Supply Voltage (V_{DD})

Test Circuits

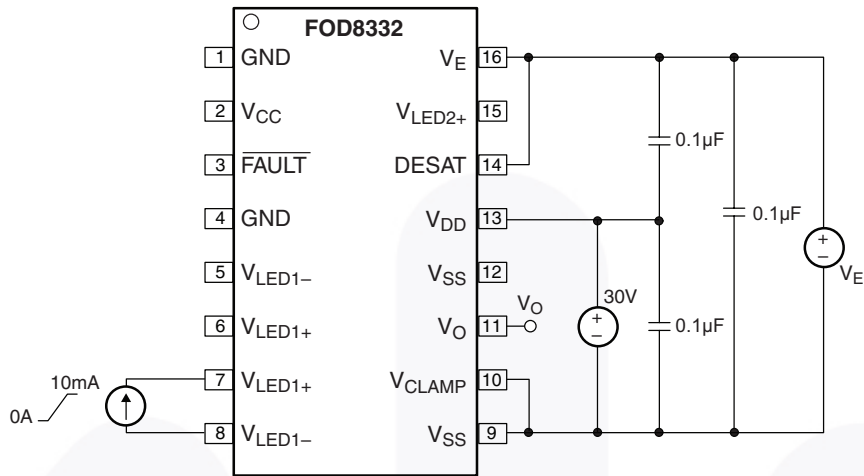

Figure 30. Threshold Input Current Low-to-High (I_{FLH}) Test Circuit

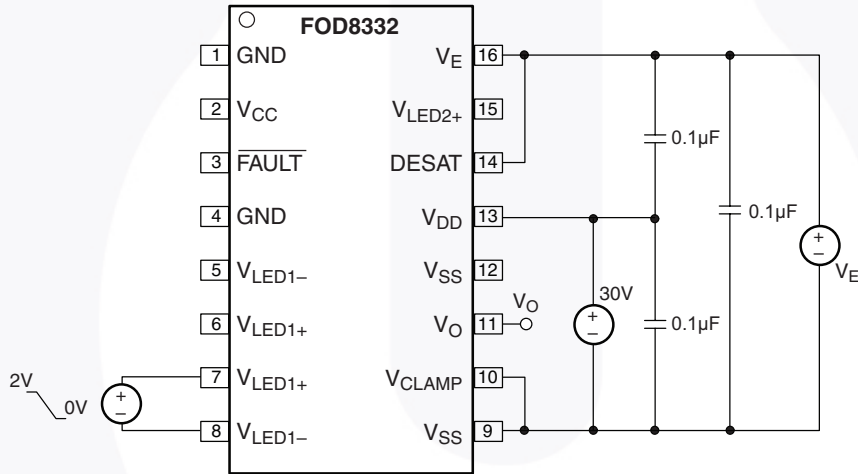

Figure 31. Threshold Input Voltage High-to-Low (V_{FHL}) Test Circuit

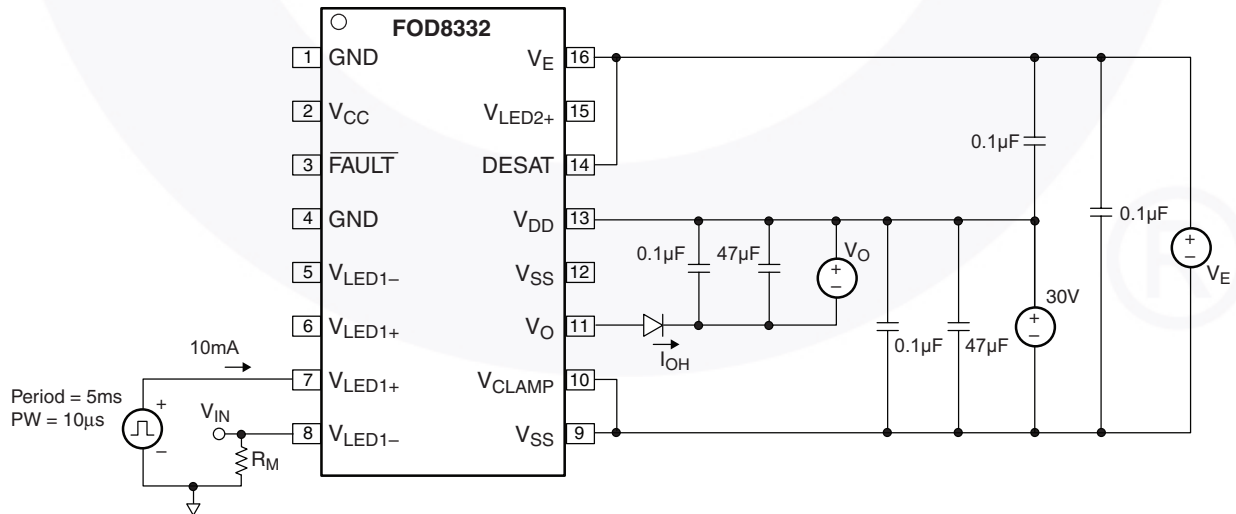

Figure 32. High Level Output Current (I_{OH}) Test Circuit

Test Circuits (Continued)

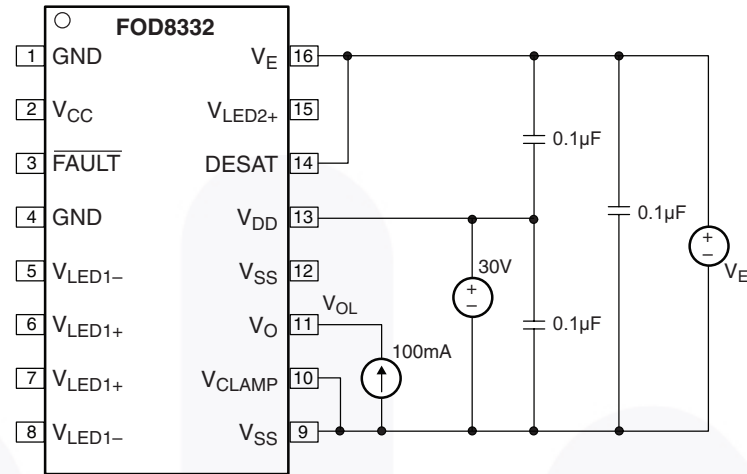

Figure 36. Low Level Output Voltage (V_{OL}) Test Circuit

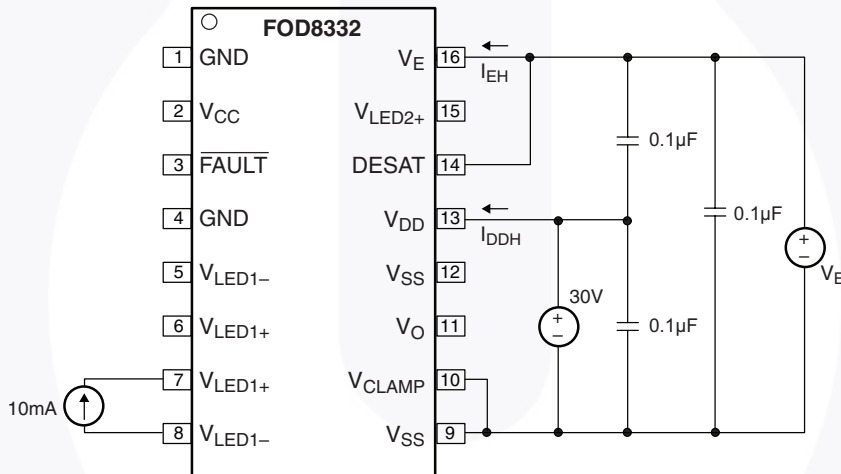

Figure 37. High Level Supply Current (I_{DDH}), V_E High Level Supply Current (I_{EH}) Test Circuit

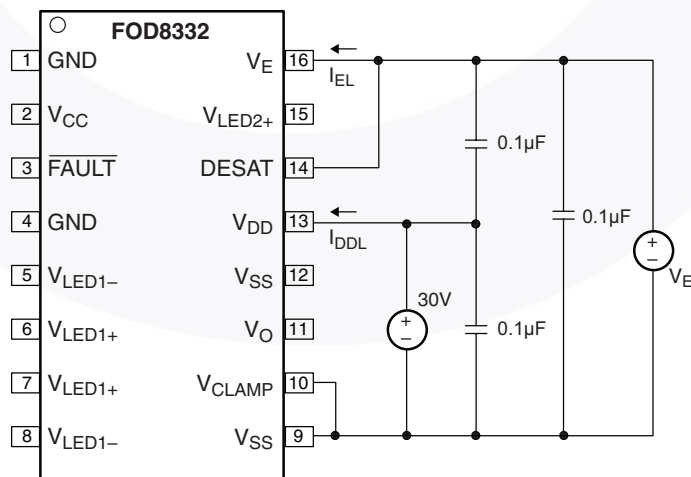

Figure 38. Low Level Supply Current (I_{DDL}), V_E Low Level Supply Current (I_{EL}) Test Circuit

Test Circuits (Continued)

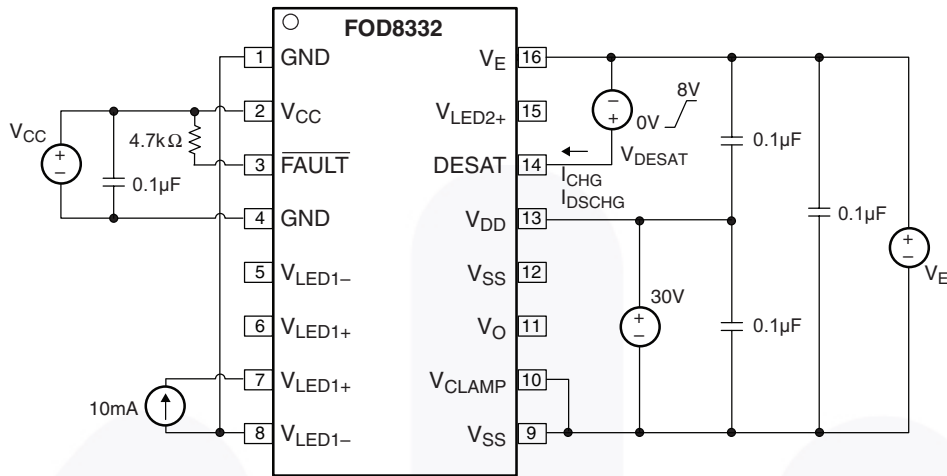

Figure 39. DESAT Threshold (V_{DESAT}), Blanking Capacitor Charge Current (I_{CHG}), Blanking Capacitor Discharge Current (I_{DSCHG}) Test Circuit

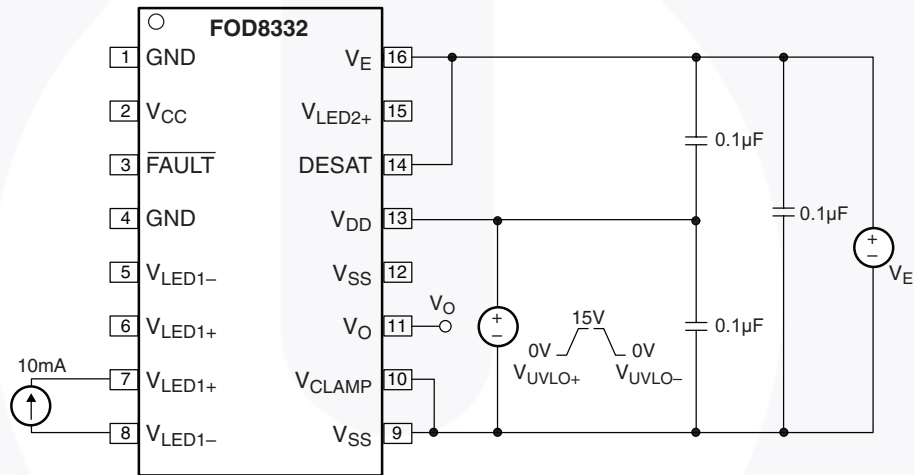

Figure 40. Under-Voltage Lockout Threshold (V_{UVLO+} / V_{UVLO-}), Under-Voltage Lockout Threshold Hysteresis ($UVLO_{HYS}$) Test Circuit

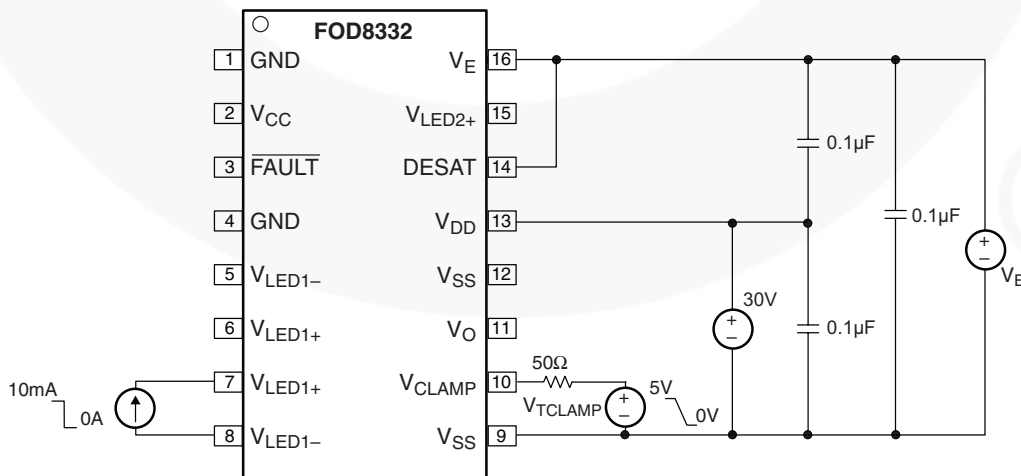

Figure 41. Clamping Threshold Voltage (V_{CLAMP_THRES}) Test Circuit

Test Circuits (Continued)

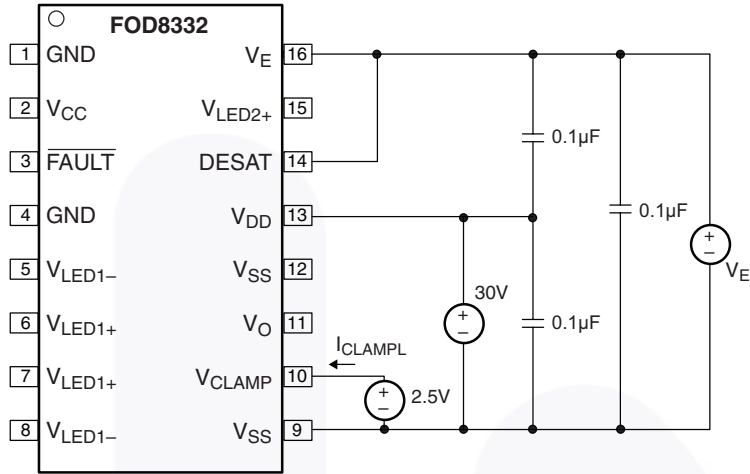

Figure 42. Clamp Low Level Sinking Current (I_{CLAMP}) Test Circuit

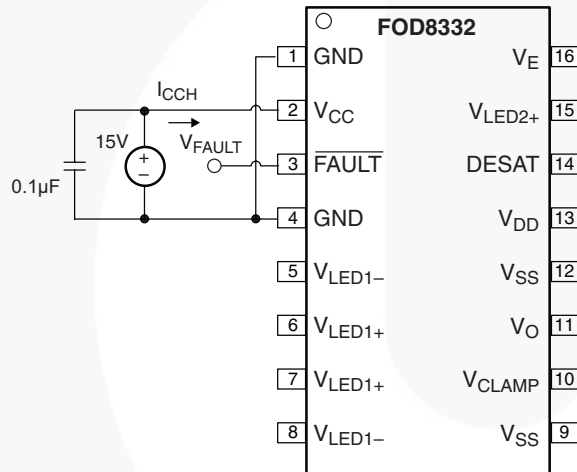

Figure 43. FAULT High Level Supply Current (I_{CCH}) Test Circuit

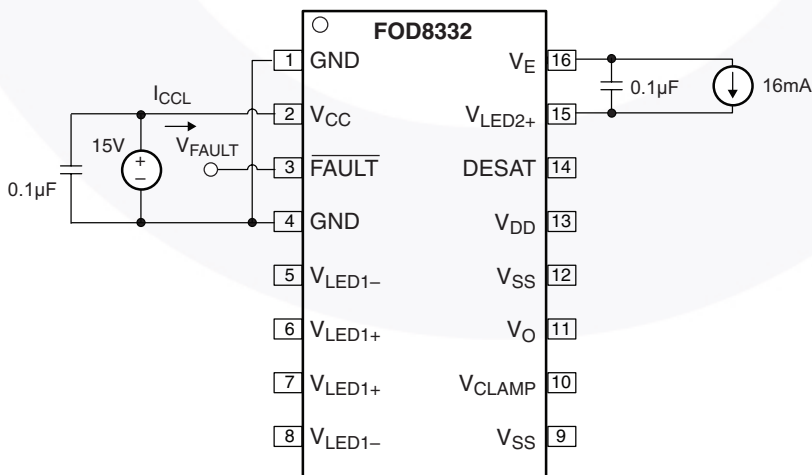

Figure 44. FAULT Low Level Supply Current (I_{CCL}) Test Circuit

Test Circuits (Continued)

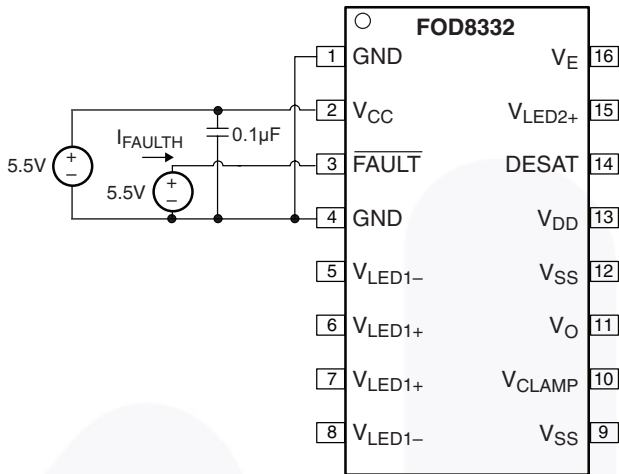

Figure 45. FAULT High Level Output Current (I_{FAULTH}) Test Circuit

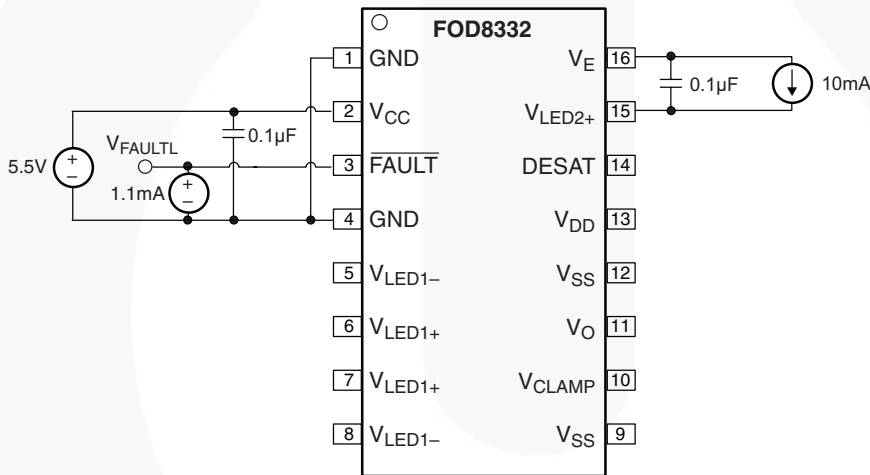

Figure 46. FAULT Low Level Output Voltage (V_{FAULTL}) Test Circuit

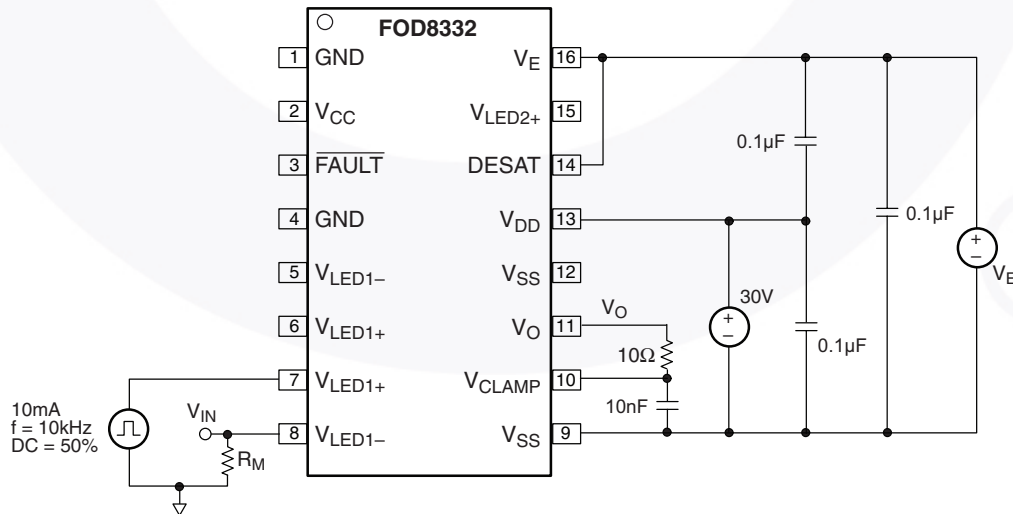

Figure 47. Propagation Delay (t_{PLH} , t_{PHL}), Rise Time (t_{R}), Fall Time (t_{F}), Pulse Width Distortion (PWD) Test Circuit

Test Circuits (Continued)

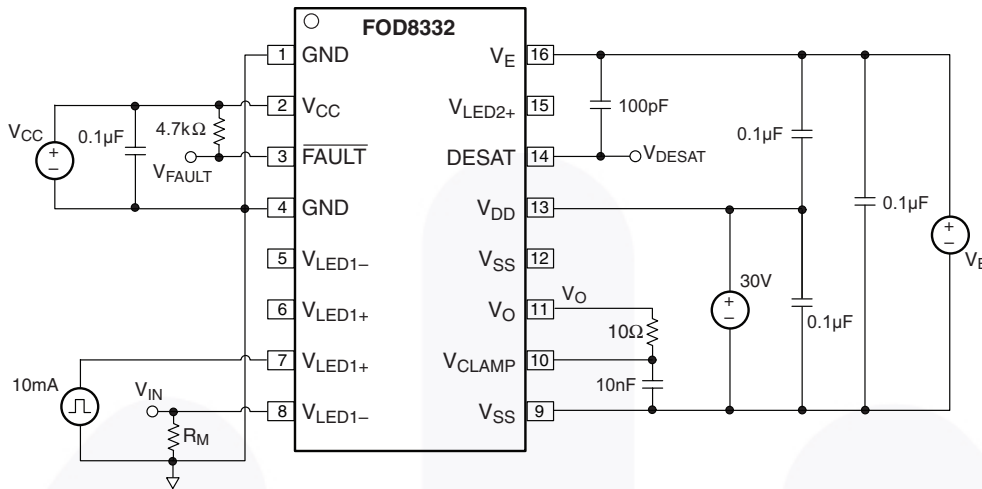

Figure 48. DESAT Sense Delay ($t_{DESAT(90\%)}$), $t_{DESAT(10\%)}$, $t_{DESAT(Low)}$), DESAT Sense to Low Level FAULT Signal Delay ($t_{DESAT(FAULT)}$), Reset to High Level FAULT Signal Delay ($t_{RESET(FAULT)}$), DESAT Input Mute ($t_{DESAT(MUTE)}$) Test Circuit

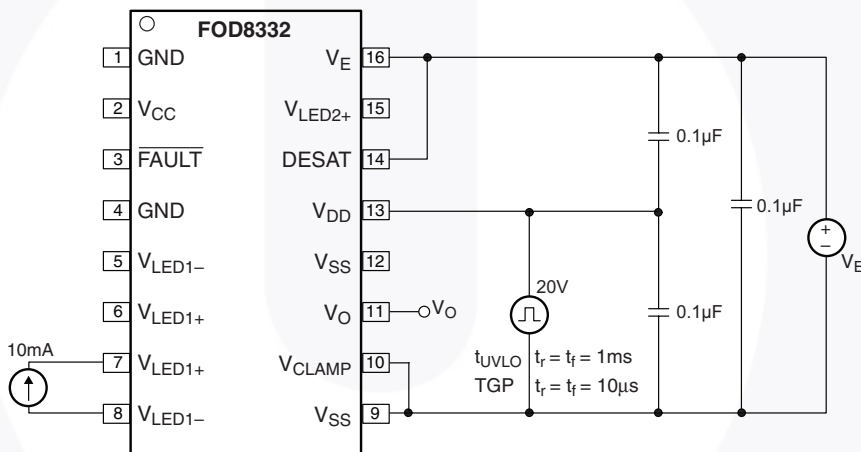

Figure 49. Under-Voltage Lockout Delay (t_{UVLO}), Time-to-Good-Power (t_{GTP}) Test Circuit

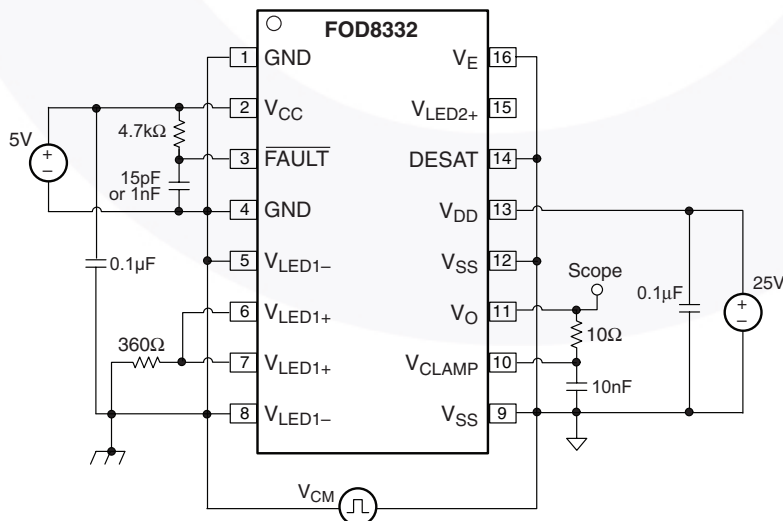

Figure 50. Common-Mode Low (CML) LED1-Off Test Circuit

Test Circuits (Continued)

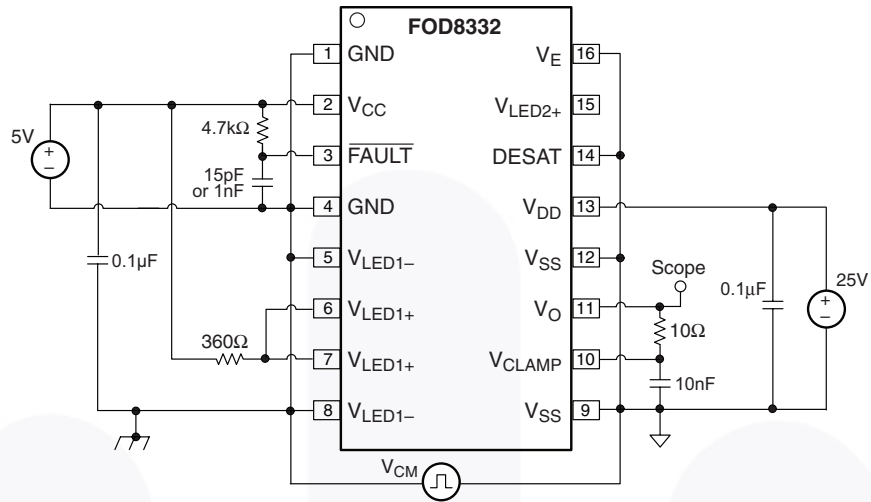

Figure 51. Common-Mode High (CMH) LED1-On Test Circuit

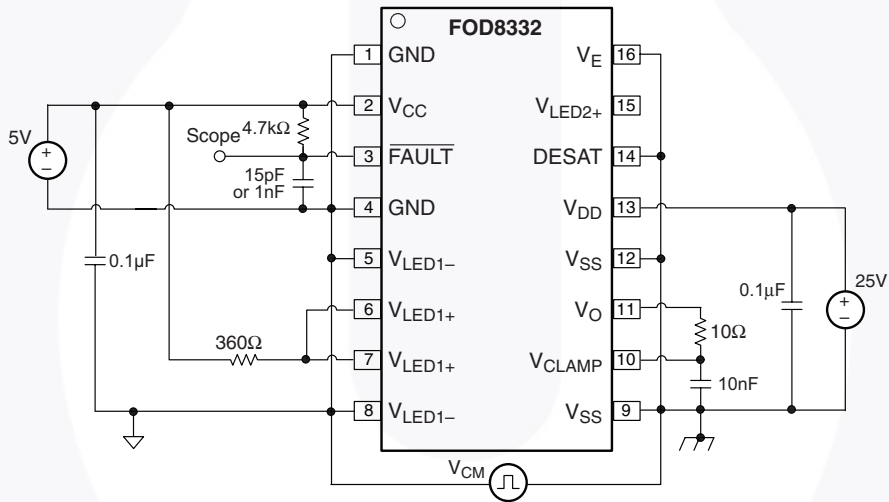

Figure 52. Common-Mode High (CMH) LED2-Off Test Circuit

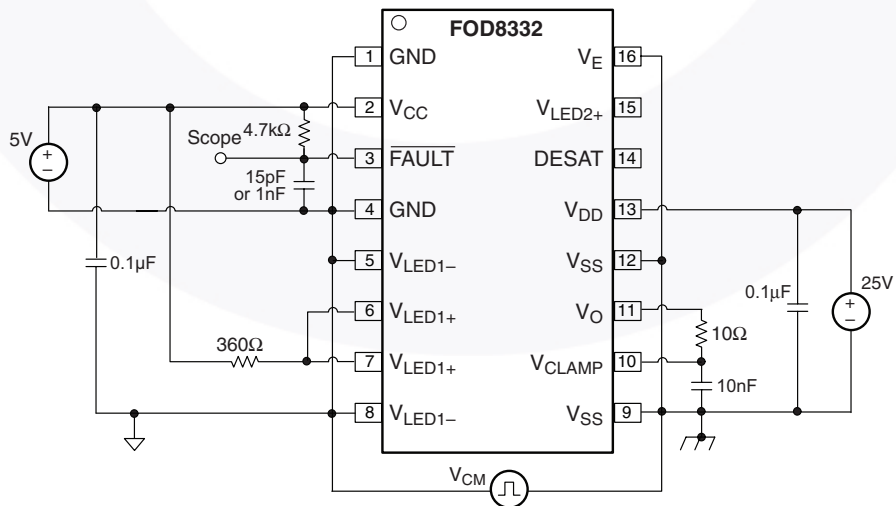

Figure 53. Common-Mode High (CML) LED2-On Test Circuit

Application Information

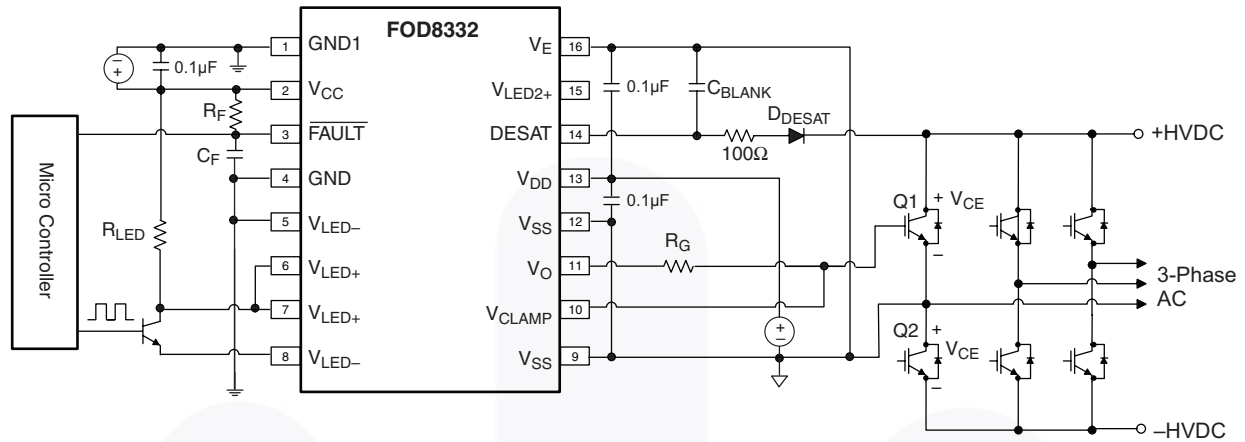

Figure 54. Recommended Application Circuit

Functional Description

The functional behavioral of FOD8332 is illustrated by the detailed internal schematic shown in Figure 55.

Figure 55 and the timing diagrams explain the interaction and sequence of internal and external signals.

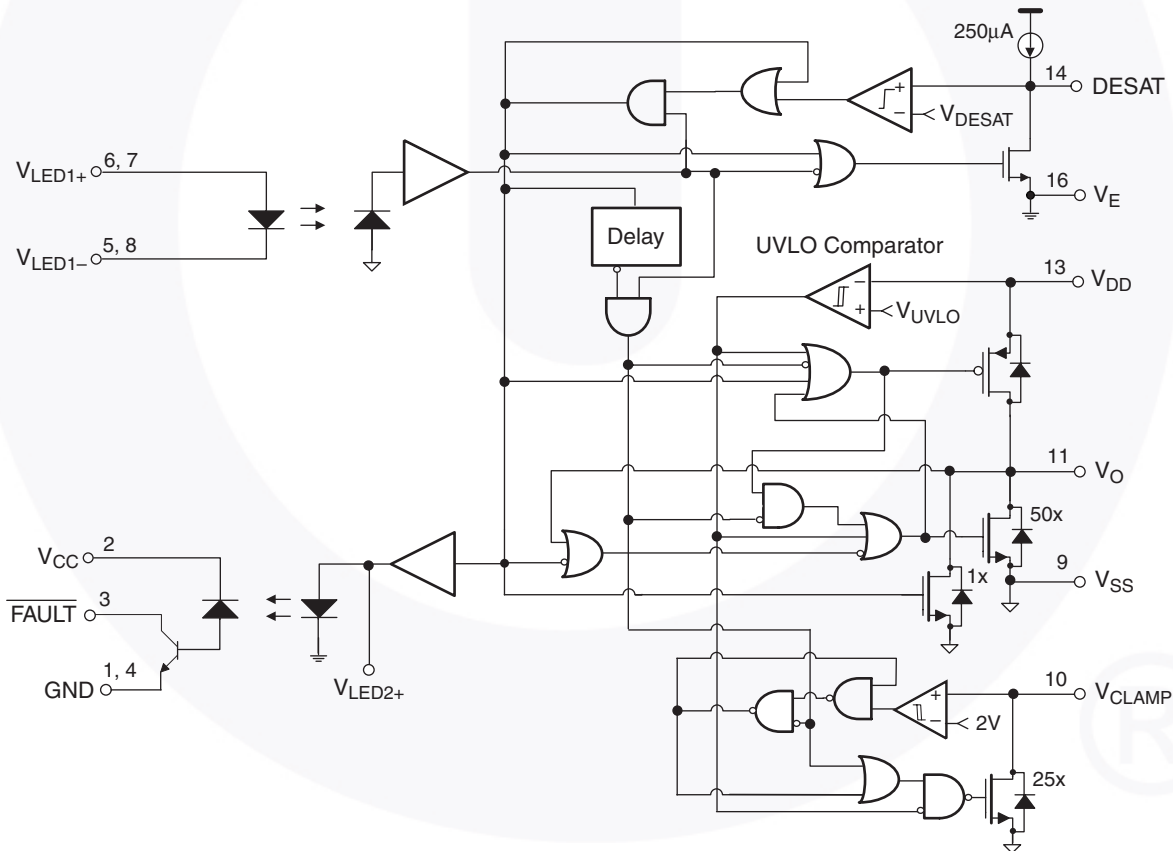

Figure 55. Detailed Internal Behavioral Schematic

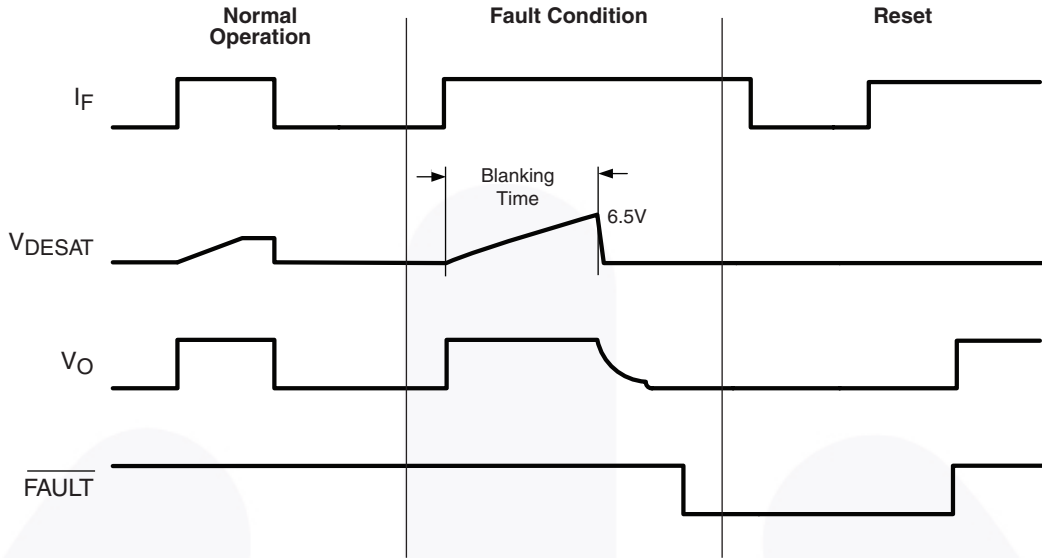

Figure 56. Operating Relationship Among Desaturation Voltage (DESAT), Fault Output (FAULT), and Reset Conditions

1. LED Input and Operation Explanation

FOD8332 is an advanced IGBT gate-drive optocoupler capable of driving most 1200 V / 150 A IGBTs and power MOSFETs in motor control and inverter applications. The following section describes driving IGBT, but is also applicable to driving MOSFET. Adjust the V_{DD} supply based on the gate threshold voltages. Critical protection features and controls are incorporated to simplify the design and improve reliability. The device includes an IGBT desaturation detection protection and a FAULT status output.

This highly integrated device consists of two high-performance AlGaAs LEDs and two integrated circuits. LED1 directly controls the isolated gate driver IC output, while the returned optical signal path is transmitted by LED2, which reports the fault status through the open-collector fault-sense IC output.

The control LED input and the fault-sense IC output can be connected to a standard 3.3 V / 5 V DSP or microcontroller. The gate driver output can be connected to the gate of the power devices on the high-voltage side. A typical recommended application is shown in Figure 54. A typical shunt LED drive can be used to improve noise immunity. The LED is connected in parallel with the bipolar transistor switch, creating a current shunt drive. Common-mode transients from the load coupling via the package capacitance can be coupled into a low-impedance path, either the conducting LED or the on resistance of the conducting bipolar transistor, increasing its noise immunity.

During normal operation, when no fault is detected, LED1 controls the gate driver output. V_O is set to HIGH

when the current flowing from the anode to the cathode (LED1) is greater than I_{FLH} and the forward voltage V_F is greater than $V_F(MIN)$. The timing relationship between the LED input and gate driver output is illustrated in Figure 3. When a fault is detected, the gate driver output IC immediately enters “soft” turn-off mode, where the output voltage changes slowly from HIGH to LOW state. This also disables the gate control input on the gate driver IC side for a minimum mute time of 10 μs .

The FAULT output, which is open-collector configuration, is latched to LOW state to report a fault status to the microcontroller. It is only reset or pulled back to HIGH when LED1 is pulled from LOW to HIGH again.

The active Miller clamp function avoids the need of negative gate driving in most applications and allows the use of a simple bootstrap supply for the high-side driver.

2. Gate Driver Output

A pair of PMOS and NMOS make up the output driver stage, which facilitates close to rail-to-rail output swing. This feature allows tight control of gate voltage during on-state and short-circuit conditions.

The output driver can typically sink 2.5 A and source 2.5 A at room temperature. Due to the low $R_{DS(ON)}$ of the MOSFETs, the power dissipation is lower than bipolar-type driver output stages. The absolute maximum rating of the output peak current, $I_{O(PEAK)}$, is 3 A. Careful selection of the gate resistor, R_G , is required to avoid violation of this rating. For charging and discharging, the R_G value is approximated by:

$$R_G = \frac{V_{CC} - V_{EE} - V_{OL}}{I_{OL(PEAK)}} \quad (1)$$

As shown in Figure 55, the gate driver output is influenced by signals from the photodetector circuitry, the UVLO comparator, and the DESAT signals. Under no-fault condition, normal operation resumes while the supply voltage is above the UVLO threshold and the output of the photodetector drives the MOSFETs of the output stage. The logic circuitry of the output stage ensures that the push-pull devices are never turned ON simultaneously. When the output of the photodetector is HIGH, output V_O is pulled to HIGH state by turning on the PMOS. When the output of the photodetector is LOW, V_O is pulled to LOW state by turning on the 50XNMOS.

When V_{DD} supply goes below V_{UVLO} , which is the designated ULVO threshold at the comparator, V_O is pulled to LOW state regardless of photodetector output.

When V_O is HIGH and desaturation is detected, V_O turns off slowly as it is pulled LOW by the 1XNMOS device. The input to the fault-sense circuitry is latched to HIGH state and turns on the LED2. The fault-sense signal remains in HIGH state until LED1 is switched from LOW to HIGH. When V_O goes below 2 V, the 50XNMOS device turns on, clamping the IGBT gate firmly to V_{SS} .

3. Desaturation Protection, FAULT Output and FAULT RESET

Desaturation detection protects the IGBT in short circuit by monitoring the collector-emitter voltage of the IGBT when it's turned on. When the DESAT pin voltage goes above the threshold voltage, a short-circuit condition is detected and the driver output stage executes a "soft" IGBT turn-off and is eventually driven LOW. This sequence is illustrated in Figure 56. The FAULT open-collector output is triggered active LOW to report a desaturation error. The gate driver output is muted for minimum of 10 μ s. All input LED signals are ignored during the mute period to allow the driver to completely soft shutdown the IGBT. The fault mechanism is reset by the next LED turn-on after the $t_{RESET(FAULT)}$ (see Figure 56). During OFF state of the IGBT, or if V_O is LOW, the fault sense circuitry is disabled to prevent false fault signals.

The DESAT comparator should be disabled for a short time period (blanking time) before the IGBT turns on to allow the collector voltage to fall below the DESAT threshold.

This blanking period protects against false triggering of the DESAT while the IGBT is turning on. The blanking time is controlled by the internal DESAT charge current, the DESAT voltage threshold, and the external DESAT capacitor (capacitor between DESAT and V_E pin). The

nominal blanking time can be calculated using external capacitance (C_{BLANK}), FAULT threshold voltage (V_{DESAT}), and DESAT charge current (I_{CHG}):

$$t_{BLANK} = C_{BLANK} \times V_{DESAT} / I_{CHG} \quad (2)$$

With a recommended 100 pF DESAT capacitor, the nominal blanking time is:

$$100 \text{ pF} \times 6.5 \text{ V} / 250 \text{ } \mu\text{A} = 2.6 \text{ } \mu\text{s}$$

4. Soft Turn-Off

The soft turn-off feature ensures the safe shutdown of the IGBT under fault condition. The gate-driver voltage V_O turns off the IGBT in a controlled slow manner. This reduces the voltage spike on the collector of the IGBT. Without this, the IGBT would see a heavy spike on the collector, resulting in a permanent damage to the device when it's turned off immediately. The V_O is pulled to LOW slowly in 4 μ s.

5. Under-Voltage Lockout (UVLO)

Under-Voltage detection prevents the application of insufficient gate voltage to the IGBT. This could be dangerous, as it would drive the IGBT out of saturation and into the linear operation where losses are very high and the IGBT quickly overheats. This feature ensures proper operation of the IGBTs. The output voltage, V_O , remains LOW irregardless of the inputs, as long as the supply voltage, $V_{DD} - V_E$, is less than V_{UVLO+} during power up. When the supply voltage falls below V_{UVLO-} , V_O goes LOW, as illustrated in Figure 57.

6. Active Miller Clamp Function

An active Miller clamp feature allows the sinking of the Miller current to ground during a high-dV/dt situation. Instead of driving the IGBT gate to a negative supply voltage to increase the safety margin, the device has a dedicated V_{CLAMP} pin to control the Miller current. During turn-off, the gate voltage of the IGBT is monitored and the V_{CLAMP} output is activated when the gate voltage goes below 2 V (relative to V_{SS}).

The Miller clamp NMOS transistor is then turned on and provides a low resistive path for the Miller current, which helps prevent a self-turn-on due to the parasitic Miller capacitor in power switches. The clamp voltage is $V_{SS} + 2.5 \text{ V}$, typical for a Miller current up to 1100 mA.

In this way, the V_{CLAMP} function does not affect the turn-off characteristic. It helps to clamp the gate to the low level throughout the turn-off time. During turn-on, where the input of the driver is activated, the V_{CLAMP} function is disabled or opened.

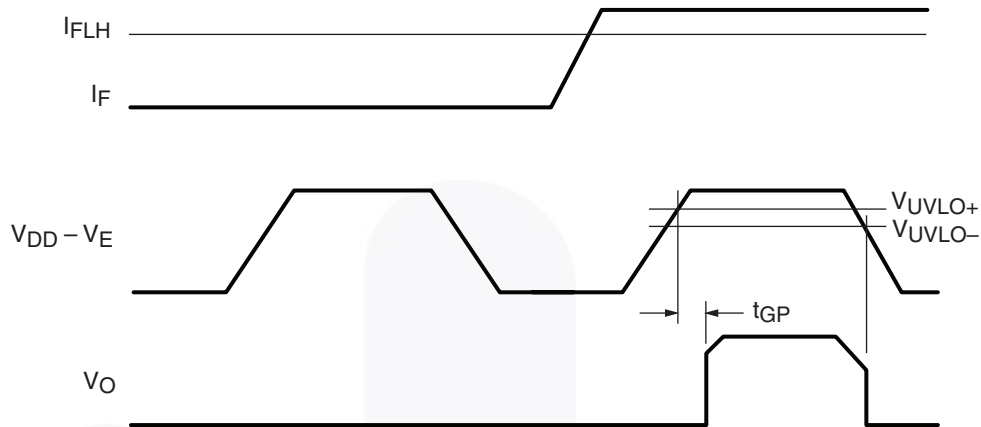

Figure 57. Time to Good Power

7. Time to Good Power

During fast power up (e.g. bootstrap power supply), the LED is off and the output of the gate driver should be in the LOW or OFF state. Sometimes, race conditions exist that cause the output to follow V_{DD} until all of the circuits in the output IC stabilize. This condition can result in output transitions or transients that are coupled to the driven IGBT. These glitches can cause the high- and low-side IGBTs to conduct shoot-through current that can damage the power semiconductor devices.

Fairchild has introduced a initial turn-on delay, called “time to good power.” This delay, typically $2.0 \mu\text{s}$, is only present during the initial power-up of the device. If the LED is ON during the initial turn-on activation, low-to-high transition at the output of the gate driver only occurs $2.0 \mu\text{s}$ after the V_{DD} power is applied.

8. Dual Supply Operation – Negative Bias at V_{SS}

The IGBT’s off-state noise immunity can be enhanced by providing a negative gate-to-emitter bias when the IGBT is in OFF state. This static off-state bias can be supplied by connecting a separate negative voltage source between the V_E (pin 16) and V_{SS} (pin 9 and pin 12). The primary ground reference is the IGBT’s emitter connection, V_E (pin 16). The under-voltage lockout threshold and desaturation voltage detection are referenced to the IGBT’s emitter (V_E) ground.

The negative voltage supply at V_{SS} appears at the gate drive output, V_O , when in LOW state. When the input drives the output HIGH, the output voltage, V_O , has the potential of the V_{DD} and V_{SS} . Proper power supply bypass capacitors are added to provide paths for the instantaneous gate charging and discharging currents. The Schottky diode is recommended connected between V_E and V_{SS} to protect against a reverse voltage greater than 0.5 V . The V_{CLAMP} (pin 10) should be connected to V_{SS} when not in use.

9. DESAT Pin Protection

During turn off, especially with inductive load, a large instantaneous forward-voltage transient can appear on the freewheeling diode of the IGBT. A large negative voltage spike on the DESAT pin can result and draw substantial current out of the gate driver IC if there is not current-limiting resistor. To limit this current, a 100Ω to $1 \text{ k}\Omega$ resistor should be inserted in series with the DESAT diode. The added resistance does not change the DESAT threshold or the DESAT blanking time.

The DESAT diode protects the gate driver IC from high voltages when the IGBT is turning off, while allowing a forward I_{CHG} current of $250 \mu\text{A}$ to be conducted to sense the IGBT’s saturated collector to emitter voltage when the IGBT is turned on. A fast-recovery diode, t_{rr} below 75 ns , with sufficient reverse-voltage rating, should be used. Fairchild offers many of these ultra-fast diodes/rectifiers, such as ES1J-600V, with t_{rr} at 35 ns .

If two diodes or more are used, the required maximum reverse voltage can be reduced by half or accordingly. This modifies the trigger level for a fault condition. The sum of the DESAT diode forward-voltage and the IGBT collector-emitter V_{CE} voltage form the voltage at the DESAT pin. The trigger level for a fault condition given by:

$$V_{CE@FAULT} = V_{DESAT} - n \times V_F \quad (3)$$

where n is the number of the DESAT diodes.

10. Pull-Up Resistor on FAULT Pin

The FAULT pin is an open-collector output and can be connected as wire-OR operation with other types of protection (e.g., over-temperature, over-voltage, over-current) to alert the microcontroller. Being an open-collector output, it requires a pull-up resistor to provide a normal high output voltage level. This resistor value must be properly considered based on various IC interface requirements. The sinking current capability is given by I_{FAULT} .

11. Increasing the Output Drive Current Using an External Booster Stage

If larger gate drive capability is needed for large IGBT modules or parallel operation, an output booster stage may be added to driver for optimum performance.

A possible implementation is by a discrete NPN/PNP totem-pole configuration. These booster transistors should be fast switching and have sufficient current gain to deliver the desired peak output current.

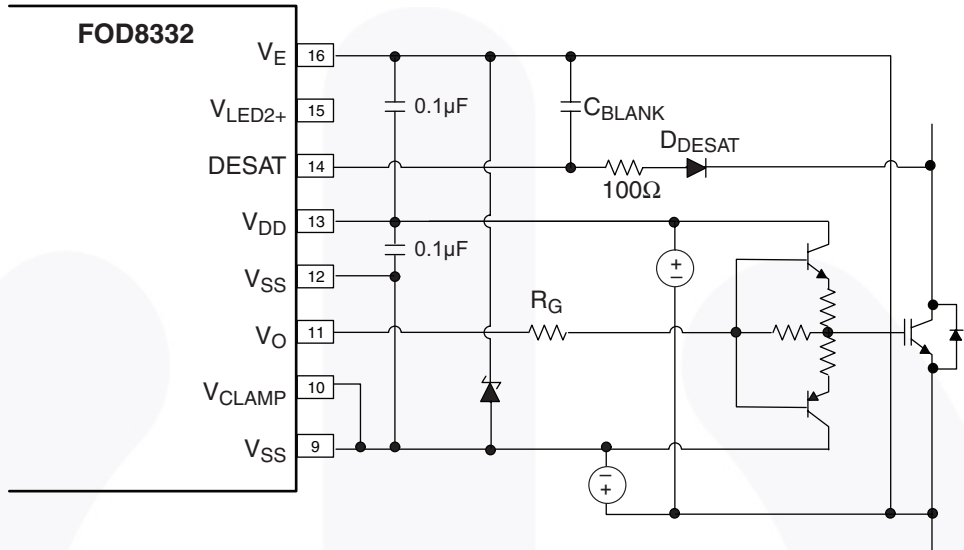



Figure 58. Output Booster Stage for Increased Output Drive Current

Ordering Information

Part Number	Package	Packing Method
FOD8332	SO 16-Pin	Tube (50 units per tube)
FOD8332R2	SO 16-Pin	Tape and Reel (750 units per reel)
FOD8332V	SO 16-Pin, DIN EN/IEC 60747-5-5 option	Tube (50 units per tube)
FOD8332R2V	SO 16-Pin, DIN EN/IEC 60747-5-5 option	Tape and reel (750 units per reel)

 All packages are lead free per JEDEC: J-STD-020B standard.

Marking Information

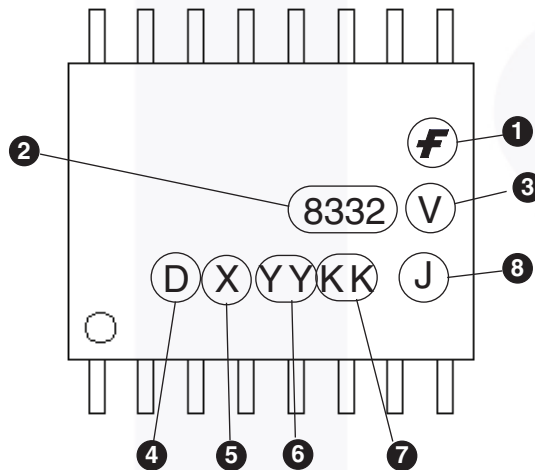

Definitions

1	Fairchild logo
2	Device number, e.g., '8332' for FOD8332
3	DIN EN/IEC60747-5-5 Option (only appears on component ordered with this option)
4	Plant code, e.g., 'D'
5	Alphabetical year code, e.g., 'E' for 2014
6	Two-digit work week ranging from '01' to '53'
7	Lot traceability code
8	Package assembly code, e.g., 'J'

Reflow Profile

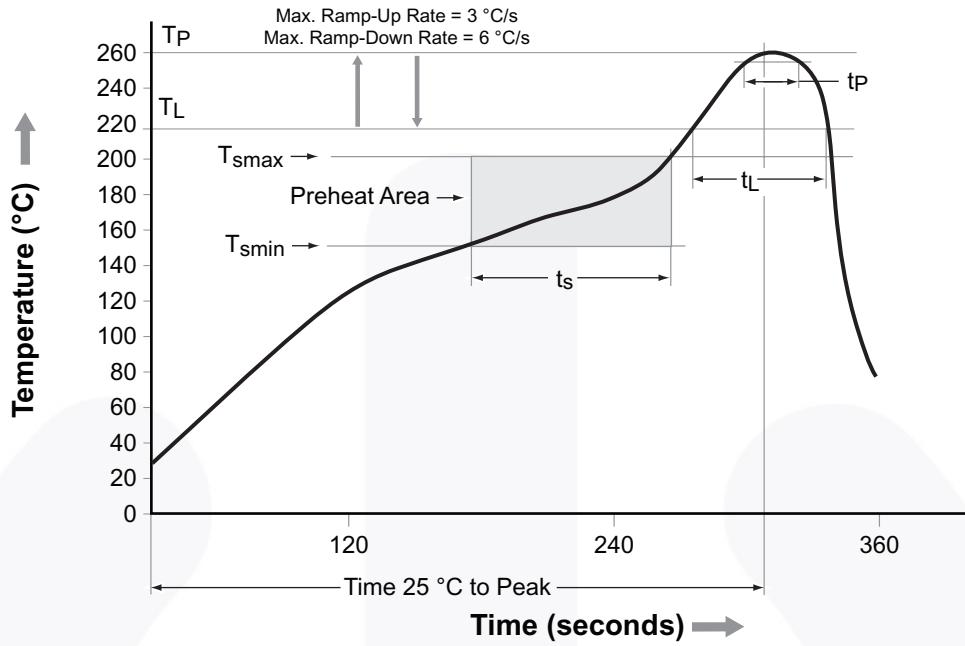
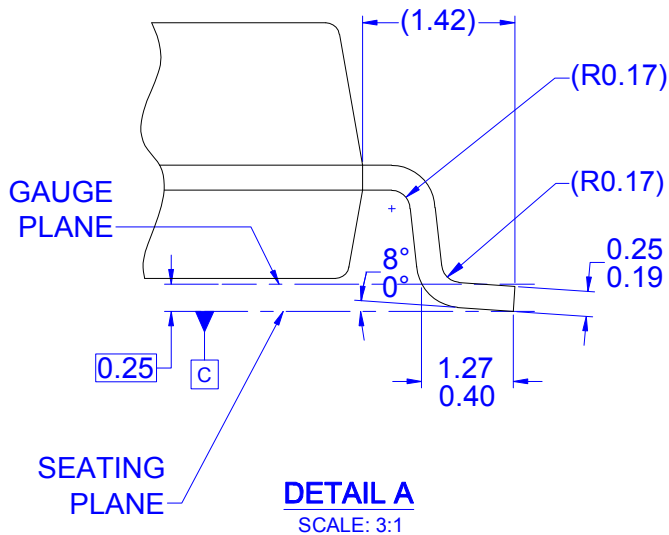
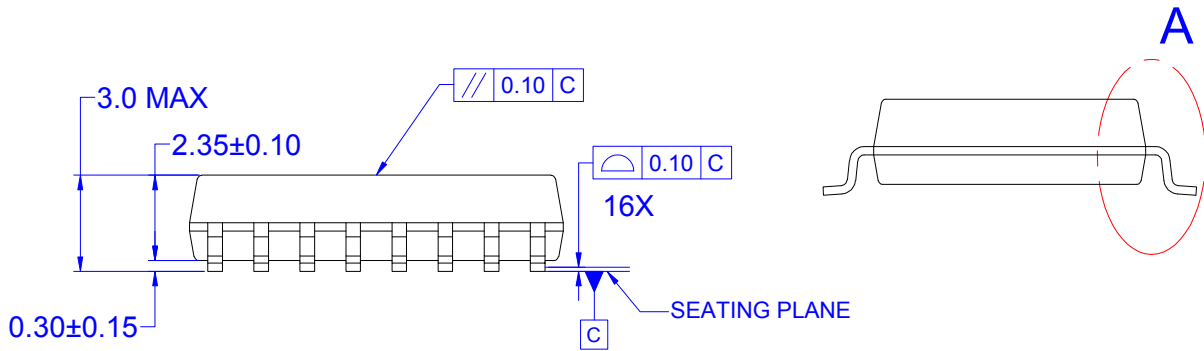
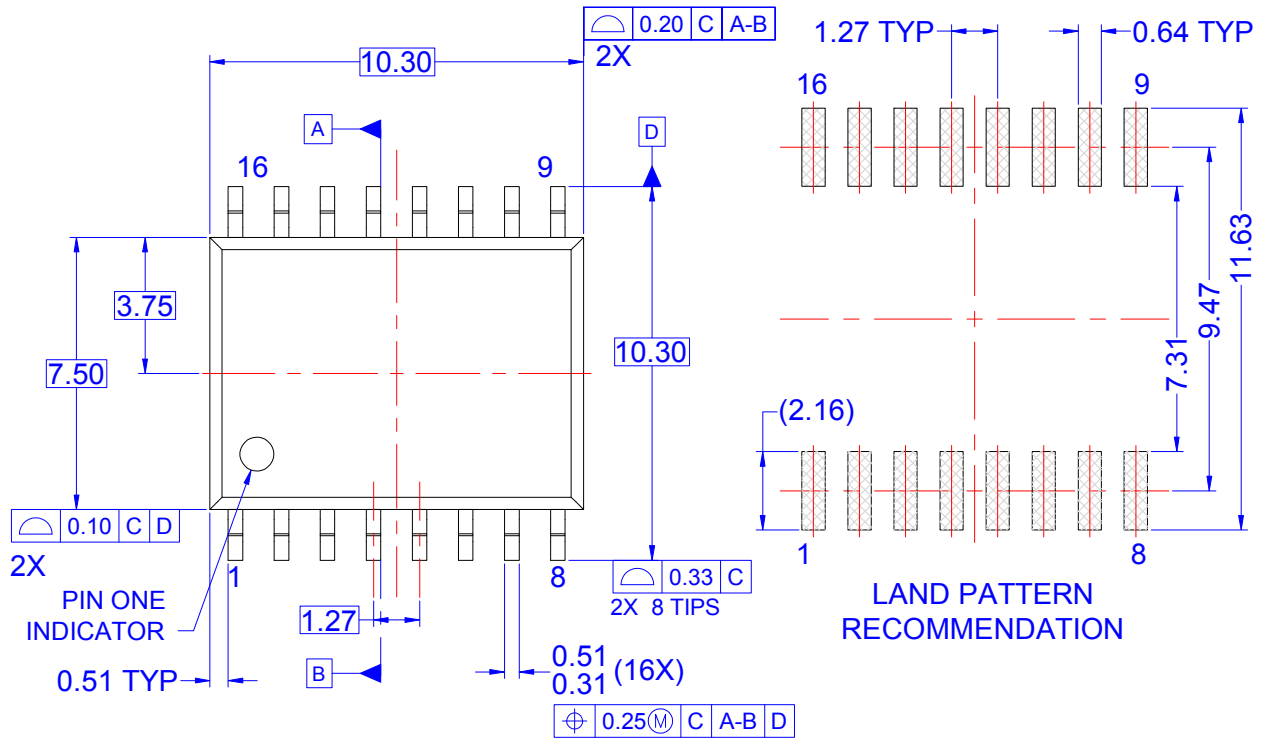

Figure 59. Reflow Profile

Profile Feature	Pb-Free Assembly Profile
Temperature Minimum (T_{smin})	150°C
Temperature Maximum (T_{smax})	200°C
Time (t_s) from (T_{smin} to T_{smax})	60–120 seconds
Ramp-up Rate (t_L to t_p)	3°C/second maximum
Liquidous Temperature (T_L)	217°C
Time (t_L) Maintained Above (T_L)	60–150 seconds
Peak Body Package Temperature	260°C +0°C / -5°C
Time (t_p) within 5°C of 260°C	30 seconds
Ramp-Down Rate (T_P to T_L)	6°C/second maximum
Time 25°C to Peak Temperature	8 minutes maximum



NOTES: UNLESS OTHERWISE SPECIFIED

- A) DRAWING REFERS TO JEDEC MS-013, VARIATION AA.
- B) ALL DIMENSIONS ARE IN MILLIMETERS.
- C) DIMENSIONS ARE EXCLUSIVE OF BURRS, MOLD FLASH AND TIE BAR PROTRUSIONS
- D) DRAWING CONFORMS TO ASME Y14.5M-1994
- E) LAND PATTERN STANDARD: SOIC127P1030X275-16N
- F) DRAWING FILE NAME: MKT-M16FREV2

ON Semiconductor and  are trademarks of Semiconductor Components Industries, LLC dba ON Semiconductor or its subsidiaries in the United States and/or other countries. ON Semiconductor owns the rights to a number of patents, trademarks, copyrights, trade secrets, and other intellectual property. A listing of ON Semiconductor's product/patent coverage may be accessed at www.onsemi.com/site/pdf/Patent-Marking.pdf. ON Semiconductor reserves the right to make changes without further notice to any products herein. ON Semiconductor makes no warranty, representation or guarantee regarding the suitability of its products for any particular purpose, nor does ON Semiconductor assume any liability arising out of the application or use of any product or circuit, and specifically disclaims any and all liability, including without limitation special, consequential or incidental damages. Buyer is responsible for its products and applications using ON Semiconductor products, including compliance with all laws, regulations and safety requirements or standards, regardless of any support or applications information provided by ON Semiconductor. "Typical" parameters which may be provided in ON Semiconductor data sheets and/or specifications can and do vary in different applications and actual performance may vary over time. All operating parameters, including "Typicals" must be validated for each customer application by customer's technical experts. ON Semiconductor does not convey any license under its patent rights nor the rights of others. ON Semiconductor products are not designed, intended, or authorized for use as a critical component in life support systems or any FDA Class 3 medical devices or medical devices with a same or similar classification in a foreign jurisdiction or any devices intended for implantation in the human body. Should Buyer purchase or use ON Semiconductor products for any such unintended or unauthorized application, Buyer shall indemnify and hold ON Semiconductor and its officers, employees, subsidiaries, affiliates, and distributors harmless against all claims, costs, damages, and expenses, and reasonable attorney fees arising out of, directly or indirectly, any claim of personal injury or death associated with such unintended or unauthorized use, even if such claim alleges that ON Semiconductor was negligent regarding the design or manufacture of the part. ON Semiconductor is an Equal Opportunity/Affirmative Action Employer. This literature is subject to all applicable copyright laws and is not for resale in any manner.

PUBLICATION ORDERING INFORMATION

LITERATURE FULFILLMENT:

Literature Distribution Center for ON Semiconductor
19521 E. 32nd Pkwy, Aurora, Colorado 80011 USA
Phone: 303-675-2175 or 800-344-3860 Toll Free USA/Canada
Fax: 303-675-2176 or 800-344-3867 Toll Free USA/Canada
Email: orderlit@onsemi.com

N. American Technical Support: 800-282-9855 Toll Free
USA/Canada
Europe, Middle East and Africa Technical Support:
Phone: 421 33 790 2910
Japan Customer Focus Center
Phone: 81-3-5817-1050

ON Semiconductor Website: www.onsemi.com
Order Literature: <http://www.onsemi.com/orderlit>
For additional information, please contact your local
Sales Representative

Mouser Electronics

Authorized Distributor

Click to View Pricing, Inventory, Delivery & Lifecycle Information:

[ON Semiconductor:](#)

[FOD8332](#) [FOD8332R2](#) [FOD8332R2V](#) [FOD8332V](#)

Компания «Life Electronics» занимается поставками электронных компонентов импортного и отечественного производства от производителей и со складов крупных дистрибьюторов Европы, Америки и Азии.

С конца 2013 года компания активно расширяет линейку поставок компонентов по направлению коаксиальный кабель, кварцевые генераторы и конденсаторы (керамические, пленочные, электролитические), за счёт заключения дистрибьюторских договоров

Мы предлагаем:

- Конкурентоспособные цены и скидки постоянным клиентам.
- Специальные условия для постоянных клиентов.
- Подбор аналогов.
- Поставку компонентов в любых объемах, удовлетворяющих вашим потребностям.
- Приемлемые сроки поставки, возможна ускоренная поставка.
- Доставку товара в любую точку России и стран СНГ.
- Комплексную поставку.
- Работу по проектам и поставку образцов.
- Формирование склада под заказчика.
- Сертификаты соответствия на поставляемую продукцию (по желанию клиента).
- Тестирование поставляемой продукции.
- Поставку компонентов, требующих военную и космическую приемку.
- Входной контроль качества.
- Наличие сертификата ISO.

В составе нашей компании организован Конструкторский отдел, призванный помогать разработчикам, и инженерам.

Конструкторский отдел помогает осуществить:

- Регистрацию проекта у производителя компонентов.
- Техническую поддержку проекта.
- Защиту от снятия компонента с производства.
- Оценку стоимости проекта по компонентам.
- Изготовление тестовой платы монтаж и пусконаладочные работы.



Тел: +7 (812) 336 43 04 (многоканальный)

Email: org@lifeelectronics.ru