

## 14-Pin, 8-Bit CMOS Microcontroller

### Device included in this Data Sheet:

PIC16C505

### High-Performance RISC CPU:

- Only 33 instructions to learn
- Operating speed:
  - DC - 20 MHz clock input
  - DC - 200 ns instruction cycle

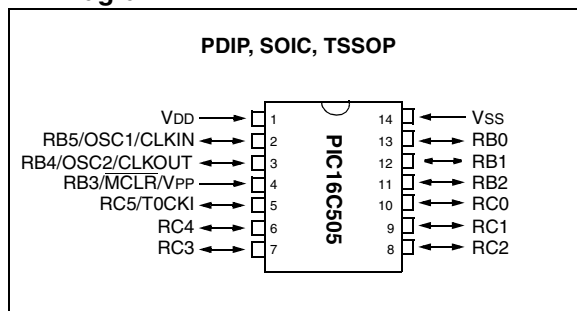
Device	Memory	
	Program	Data
PIC16C505	1024 x 12	72 x 8

- Direct, indirect and relative addressing modes for data and instructions
- 12-bit wide instructions
- 8-bit wide data path
- 2-level deep hardware stack
- Eight special function hardware registers
- Direct, indirect and relative addressing modes for data and instructions
- All single cycle instructions (200 ns) except for program branches which are two-cycle

### Peripheral Features:

- 11 I/O pins with individual direction control
- 1 input pin
- High current sink/source for direct LED drive
- Timer0: 8-bit timer/counter with 8-bit programmable prescaler

### Pin Diagram:



### Special Microcontroller Features:

- In-Circuit Serial Programming (ICSP™)
- Power-on Reset (POR)
- Device Reset Timer (DRT)
- Watchdog Timer (WDT) with dedicated on-chip RC oscillator for reliable operation
- Programmable Code Protection
- Internal weak pull-ups on I/O pins
- Wake-up from Sleep on pin change
- Power-saving Sleep mode
- Selectable oscillator options:
  - INTRC: Precision internal 4 MHz oscillator
  - EXTRC: External low-cost RC oscillator
  - XT: Standard crystal/resonator
  - HS: High speed crystal/resonator
  - LP: Power saving, low frequency crystal

### CMOS Technology:

- Low-power, high-speed CMOS EPROM technology
- Fully static design
- Wide operating voltage range (2.5V to 5.5V)
- Wide temperature ranges
  - Commercial: 0°C to +70°C
  - Industrial: -40°C to +85°C
  - Extended: -40°C to +125°C
  - < 1.0  $\mu$ A typical standby current @ 5V
- Low power consumption
  - < 2.0 mA @ 5V, 4 MHz
  - 15  $\mu$ A typical @ 3.0V, 32 kHz for TMR0 running in SLEEP mode
  - < 1.0  $\mu$ A typical standby current @ 5V

# PIC16C505

## TABLE OF CONTENTS

1.0	General Description.....	3
2.0	PIC16C505 Device Varieties.....	5
3.0	Architectural Overview.....	7
4.0	Memory Organization.....	11
5.0	I/O Port.....	19
6.0	Timer0 Module and TMR0 Register.....	23
7.0	Special Features of the CPU.....	27
8.0	Instruction Set Summary.....	39
9.0	Development Support.....	51
10.0	Electrical Characteristics - PIC16C505.....	55
11.0	DC and AC Characteristics - PIC16C505.....	69
12.0	Packaging Information.....	73
	PIC16C505 Product Identification System.....	87

## TO OUR VALUED CUSTOMERS

It is our intention to provide our valued customers with the best documentation possible to ensure successful use of your Microchip products. To this end, we will continue to improve our publications to better suit your needs. Our publications will be refined and enhanced as new volumes and updates are introduced.

If you have any questions or comments regarding this publication, please contact the Marketing Communications Department via E-mail at [docerrors@microchip.com](mailto:docerrors@microchip.com) or fax the **Reader Response Form** in the back of this data sheet to (480) 792-4150. We welcome your feedback.

### Most Current Data Sheet

To obtain the most up-to-date version of this data sheet, please register at our Worldwide Web site at:

<http://www.microchip.com>

You can determine the version of a data sheet by examining its literature number found on the bottom outside corner of any page. The last character of the literature number is the version number, (e.g., DS30000A is version A of document DS30000).

### Errata

An errata sheet, describing minor operational differences from the data sheet and recommended workarounds, may exist for current devices. As device/documentation issues become known to us, we will publish an errata sheet. The errata will specify the revision of silicon and revision of document to which it applies.

To determine if an errata sheet exists for a particular device, please check with one of the following:

- Microchip's Worldwide Web site; <http://www.microchip.com>
- Your local Microchip sales office (see last page)

When contacting a sales office, please specify which device, revision of silicon and data sheet (include literature number) you are using.

### Customer Notification System

Register on our web site at [www.microchip.com](http://www.microchip.com) to receive the most current information on all of our products.

## 1.0 GENERAL DESCRIPTION

The PIC16C505 from Microchip Technology is a low-cost, high-performance, 8-bit, fully static, EPROM/ROM-based CMOS microcontroller. It employs a RISC architecture with only 33 single word/single cycle instructions. All instructions are single cycle (200  $\mu$ s) except for program branches, which take two cycles. The PIC16C505 delivers performance an order of magnitude higher than its competitors in the same price category. The 12-bit wide instructions are highly symmetrical resulting in a typical 2:1 code compression over other 8-bit microcontrollers in its class. The easy to use and easy to remember instruction set reduces development time significantly.

The PIC16C505 product is equipped with special features that reduce system cost and power requirements. The Power-On Reset (POR) and Device Reset Timer (DRT) eliminate the need for external reset circuitry. There are five oscillator configurations to choose from, including INTRC internal oscillator mode and the power-saving LP (Low Power) oscillator mode. Power saving SLEEP mode, Watchdog Timer and code protection features improve system cost, power and reliability.

The PIC16C505 is available in the cost-effective One-Time-Programmable (OTP) version, which is suitable for production in any volume. The customer can take full advantage of Microchip's price leadership in OTP microcontrollers, while benefiting from the OTP's flexibility.

The PIC16C505 product is supported by a full-featured macro assembler, a software simulator, an in-circuit emulator, a 'C' compiler, a low-cost development programmer and a full featured programmer. All the tools are supported on IBM<sup>®</sup> PC and compatible machines.

## 1.1 Applications

The PIC16C505 fits in applications ranging from personal care appliances and security systems to low-power remote transmitters/receivers. The EPROM technology makes customizing application programs (transmitter codes, appliance settings, receiver frequencies, etc.) extremely fast and convenient. The small footprint packages, for through hole or surface mounting, make this microcontroller perfect for applications with space limitations. Low-cost, low-power, high-performance, ease of use and I/O flexibility make the PIC16C505 very versatile even in areas where no microcontroller use has been considered before (e.g., timer functions, replacement of "glue" logic and PLD's in larger systems, and coprocessor applications).

# PIC16C505

---

---

**TABLE 1-1: PIC16C505 DEVICE**

		PIC16C505
<b>Clock</b>	Maximum Frequency of Operation (MHz)	20
<b>Memory</b>	EPROM Program Memory	1024
	Data Memory (bytes)	72
<b>Peripherals</b>	Timer Module(s)	TMRO
	Wake-up from SLEEP on pin change	Yes
<b>Features</b>	I/O Pins	11
	Input Pins	1
	Internal Pull-ups	Yes
	In-Circuit Serial Programming	Yes
	Number of Instructions	33
	Packages	14-pin DIP, SOIC, TSSOP

The PIC16C505 device has Power-on Reset, selectable Watchdog Timer, selectable code protect, high I/O current capability and precision internal oscillator.

The PIC16C505 device uses serial programming with data pin RB0 and clock pin RB1.

## 2.0 PIC16C505 DEVICE VARIETIES

A variety of packaging options are available. Depending on application and production requirements, the proper device option can be selected using the information in this section. When placing orders, please use the PIC16C505 Product Identification System at the back of this data sheet to specify the correct part number.

### 2.1 One-Time-Programmable (OTP) Devices

The availability of OTP devices is especially useful for customers who need the flexibility of frequent code updates or small volume applications.

The OTP devices, packaged in plastic packages, permit the user to program them once. In addition to the program memory, the configuration bits must also be programmed.

### 2.2 Quick-Turnaround-Production (QTP) Devices

Microchip offers a QTP Programming Service for factory production orders. This service is made available for users who choose not to program medium to high quantity units and whose code patterns have stabilized. The devices are identical to the OTP devices but with all EPROM locations and fuse options already programmed by the factory. Certain code and prototype verification procedures do apply before production shipments are available. Please contact your local Microchip Technology sales office for more details.

### 2.3 Serialized Quick-Turnaround Production (SQTP<sup>SM</sup>) Devices

Microchip offers a unique programming service, where a few user-defined locations in each device are programmed with different serial numbers. The serial numbers may be random, pseudo-random or sequential.

Serial programming allows each device to have a unique number, which can serve as an entry-code, password or ID number.

# PIC16C505

---

NOTES:

## 3.0 ARCHITECTURAL OVERVIEW

The high performance of the PIC16C505 can be attributed to a number of architectural features commonly found in RISC microprocessors. To begin with, the PIC16C505 uses a Harvard architecture in which program and data are accessed on separate buses. This improves bandwidth over traditional von Neumann architecture where program and data are fetched on the same bus. Separating program and data memory further allows instructions to be sized differently than the 8-bit wide data word. Instruction opcodes are 12 bits wide, making it possible to have all single word instructions. A 12-bit wide program memory access bus fetches a 12-bit instruction in a single cycle. A two-stage pipeline overlaps fetch and execution of instructions. Consequently, all instructions (33) execute in a single cycle (200ns @ 20MHz) except for program branches.

The Table below lists program memory (EPROM) and data memory (RAM) for the PIC16C505.

Device	Memory	
	Program	Data
PIC16C505	1024 x 12	72 x 8

The PIC16C505 can directly or indirectly address its register files and data memory. All special function registers, including the program counter, are mapped in the data memory. The PIC16C505 has a highly orthogonal (symmetrical) instruction set that makes it possible to carry out any operation on any register using any addressing mode. This symmetrical nature and lack of 'special optimal situations' make programming with the PIC16C505 simple yet efficient. In addition, the learning curve is reduced significantly.

The PIC16C505 device contains an 8-bit ALU and working register. The ALU is a general purpose arithmetic unit. It performs arithmetic and Boolean functions between data in the working register and any register file.

The ALU is 8-bits wide and capable of addition, subtraction, shift and logical operations. Unless otherwise mentioned, arithmetic operations are two's complement in nature. In two-operand instructions, one operand is typically the W (working) register. The other operand is either a file register or an immediate constant. In single operand instructions, the operand is either the W register or a file register.

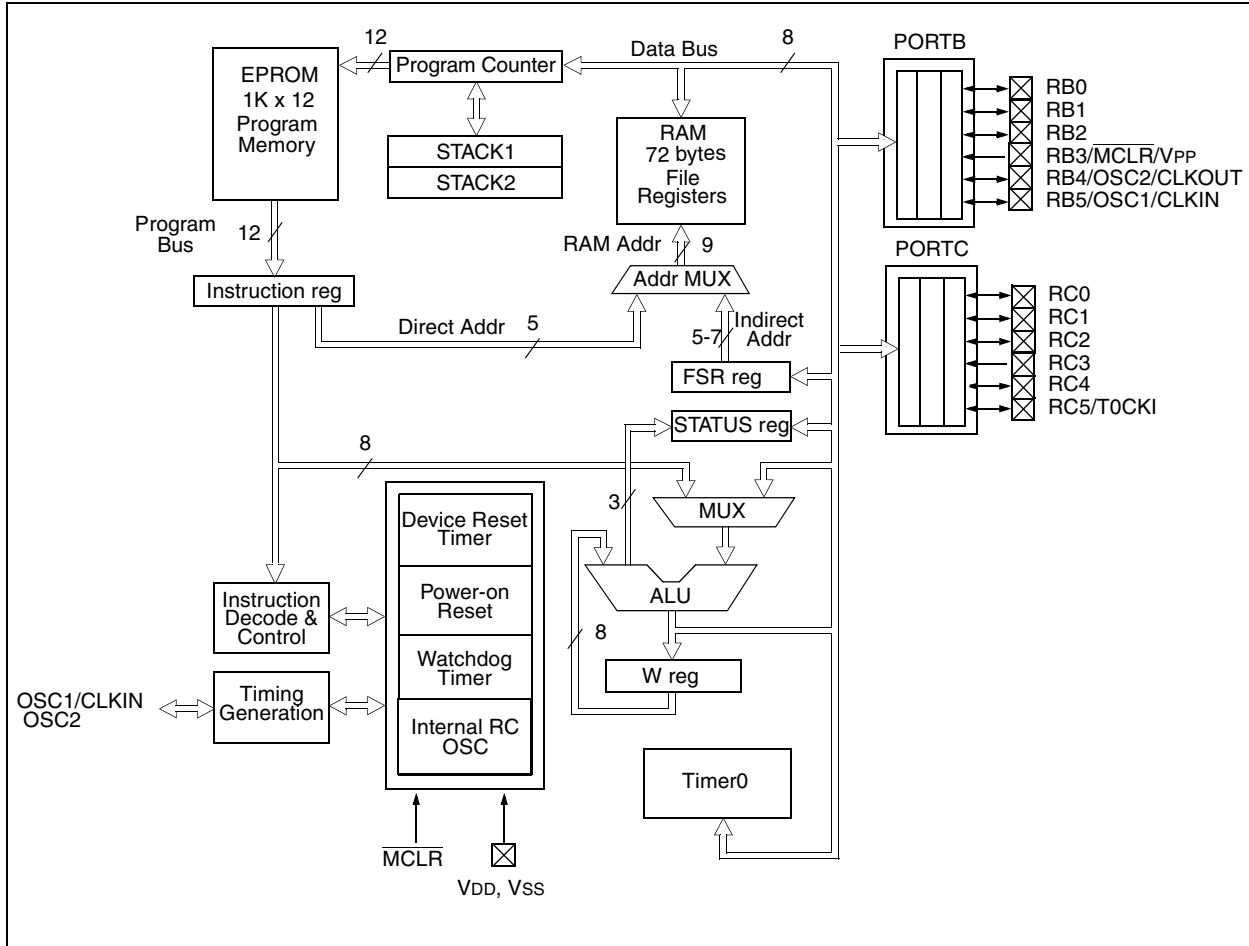
The W register is an 8-bit working register used for ALU operations. It is not an addressable register.

Depending on the instruction executed, the ALU may affect the values of the Carry (C), Digit Carry (DC), and Zero (Z) bits in the STATUS register. The C and DC bits operate as a borrow and digit borrow out bit, respectively, in subtraction. See the SUBWF and ADDWF instructions for examples.

A simplified block diagram is shown in Figure 3-1, with the corresponding device pins described in Table 3-1.

# PIC16C505

FIGURE 3-1: PIC16C505 BLOCK DIAGRAM



**TABLE 3-1: PIC16C505 PINOUT DESCRIPTION**

Name	DIP Pin #	SOIC Pin #	I/O/P Type	Buffer Type	Description
RB0	13	13	I/O	TTL/ST	Bi-directional I/O port/ serial programming data. Can be software programmed for internal weak pull-up and wake-up from SLEEP on pin change. This buffer is a Schmitt Trigger input when used in serial programming mode.
RB1	12	12	I/O	TTL/ST	Bi-directional I/O port/ serial programming clock. Can be software programmed for internal weak pull-up and wake-up from SLEEP on pin change. This buffer is a Schmitt Trigger input when used in serial programming mode.
RB2	11	11	I/O	TTL	Bi-directional I/O port.
RB3/ $\overline{\text{MCLR}}$ / $\text{VPP}$	4	4	I	TTL/ST	Input port/master clear (reset) input/programming voltage input. When configured as $\overline{\text{MCLR}}$ , this pin is an active low reset to the device. Voltage on $\overline{\text{MCLR}}$ / $\text{VPP}$ must not exceed $\text{VDD}$ during normal device operation. Can be software programmed for internal weak pull-up and wake-up from SLEEP on pin change. Weak pull-up only when configured as RB3. ST when configured as $\overline{\text{MCLR}}$ .
RB4/ $\text{OSC2}$ / $\text{CLKOUT}$	3	3	I/O	TTL	Bi-directional I/O port/oscillator crystal output. Connections to crystal or resonator in crystal oscillator mode (XT and LP modes only, RB4 in other modes). Can be software programmed for internal weak pull-up and wake-up from SLEEP on pin change. In EXTRC and INTRC modes, the pin output can be configured to $\text{CLKOUT}$ , which has 1/4 the frequency of $\text{OSC1}$ and denotes the instruction cycle rate.
RB5/ $\text{OSC1}$ / $\text{CLKIN}$	2	2	I/O	TTL/ST	Bidirectional IO port/oscillator crystal input/external clock source input (RB5 in Internal RC mode only, $\text{OSC1}$ in all other oscillator modes). TTL input when RB5, ST input in external RC oscillator mode.
RC0	10	10	I/O	TTL	Bi-directional I/O port.
RC1	9	9	I/O	TTL	Bi-directional I/O port.
RC2	8	8	I/O	TTL	Bi-directional I/O port.
RC3	7	7	I/O	TTL	Bi-directional I/O port.
RC4	6	6	I/O	TTL	Bi-directional I/O port.
RC5/ $\text{T0CKI}$	5	5	I/O	ST	Bi-directional I/O port. Can be configured as $\text{T0CKI}$ .
$\text{VDD}$	1	1	P	—	Positive supply for logic and I/O pins
$\text{VSS}$	14	14	P	—	Ground reference for logic and I/O pins

Legend: I = input, O = output, I/O = input/output, P = power, — = not used, TTL = TTL input, ST = Schmitt Trigger input

# PIC16C505

## 3.1 Clocking Scheme/Instruction Cycle

The clock input (OSC1/CLKIN pin) is internally divided by four to generate four non-overlapping quadrature clocks namely Q1, Q2, Q3 and Q4. Internally, the program counter is incremented every Q1, and the instruction is fetched from program memory and latched into the instruction register in Q4. It is decoded and executed during the following Q1 through Q4. The clocks and instruction execution flow is shown in Figure 3-2 and Example 3-1.

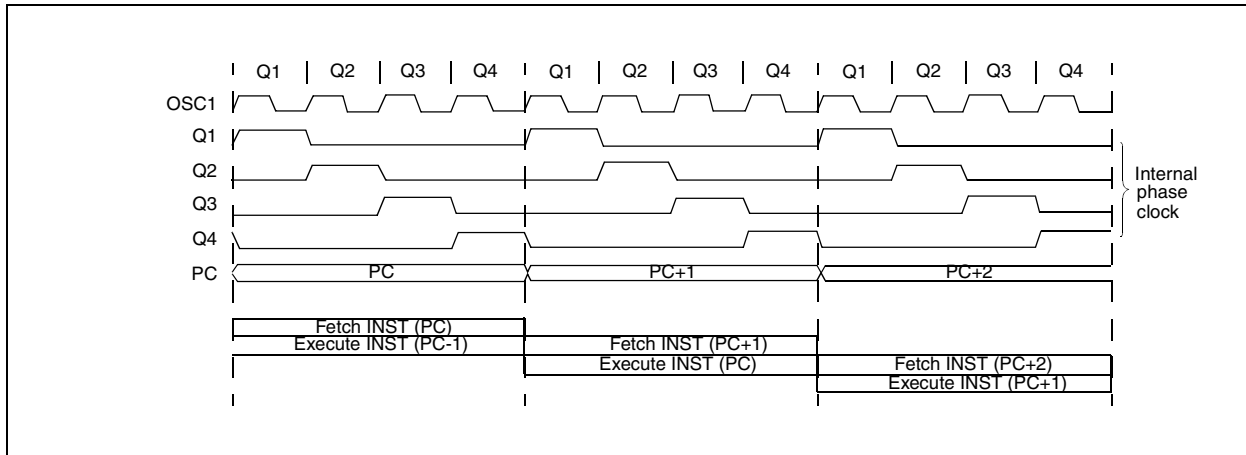
## 3.2 Instruction Flow/Pipelining

An instruction cycle consists of four Q cycles (Q1, Q2, Q3 and Q4). The instruction fetch and execute are pipelined such that fetch takes one instruction cycle, while decode and execute takes another instruction cycle. However, due to the pipelining, each instruction effectively executes in one cycle. If an instruction causes the program counter to change (e.g., GOTO) then two cycles are required to complete the instruction (Example 3-1).

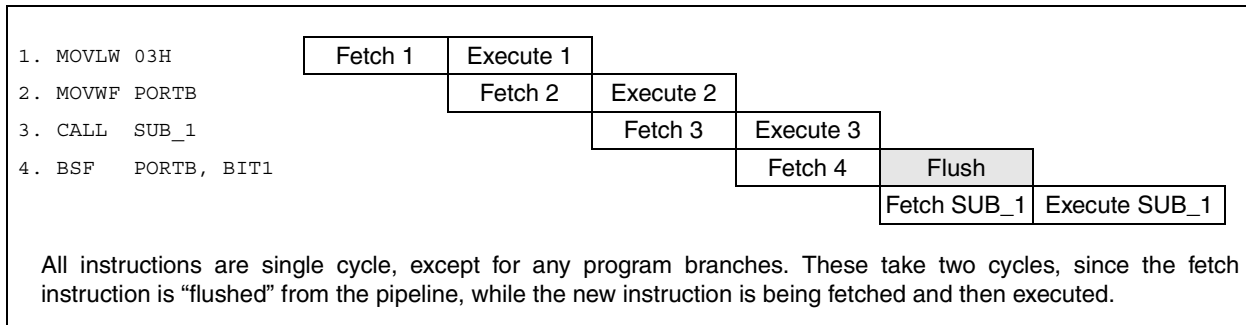
A fetch cycle begins with the program counter (PC) incrementing in Q1.

In the execution cycle, the fetched instruction is latched into the Instruction Register (IR) in cycle Q1. This instruction is then decoded and executed during the Q2, Q3 and Q4 cycles. Data memory is read during Q2 (operand read) and written during Q4 (destination write).

**FIGURE 3-2: CLOCK/INSTRUCTION CYCLE**



**EXAMPLE 3-1: INSTRUCTION PIPELINE FLOW**



## 4.0 MEMORY ORGANIZATION

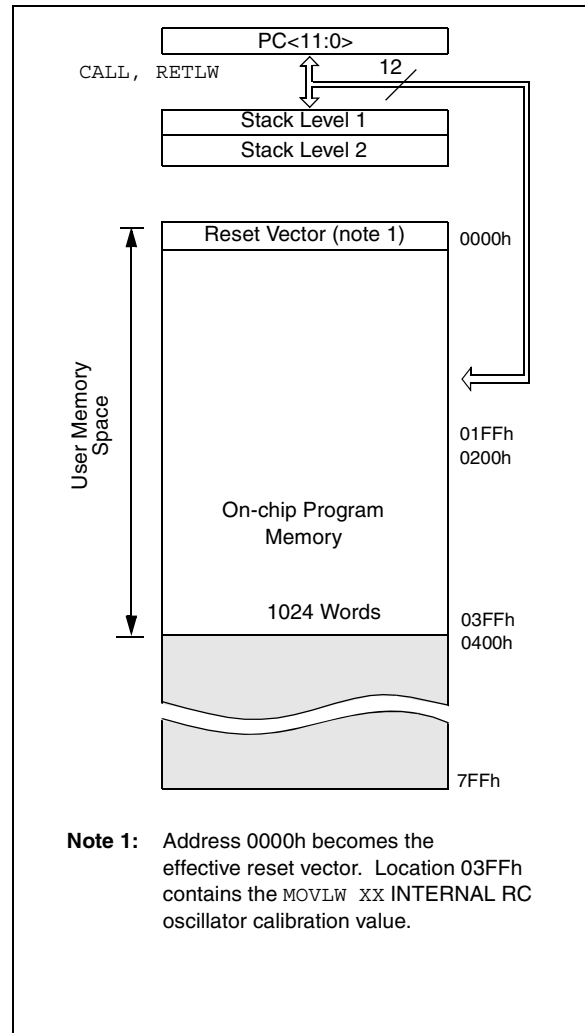
PIC16C505 memory is organized into program memory and data memory. For the PIC16C505, a paging scheme is used. Program memory pages are accessed using one STATUS register bit. Data memory banks are accessed using the File Select Register (FSR).

### 4.1 Program Memory Organization

The PIC16C505 devices have a 12-bit Program Counter (PC).

The 1K x 12 (0000h-03FFh) for the PIC16C505 are physically implemented. Refer to Figure 4-1. Accessing a location above this boundary will cause a wrap-around within the first 1K x 12 space. The effective reset vector is at 0000h, (see Figure 4-1). Location 03FFh contains the internal clock oscillator calibration value. This value should never be overwritten.

**FIGURE 4-1: PROGRAM MEMORY MAP AND STACK FOR THE PIC16C505**



# PIC16C505

## 4.2 Data Memory Organization

Data memory is composed of registers or bytes of RAM. Therefore, data memory for a device is specified by its register file. The register file is divided into two functional groups: Special Function Registers and General Purpose Registers.

The Special Function Registers include the TMR0 register, the Program Counter (PCL), the Status Register, the I/O registers (ports) and the File Select Register (FSR). In addition, Special Function Registers are used to control the I/O port configuration and prescaler options.

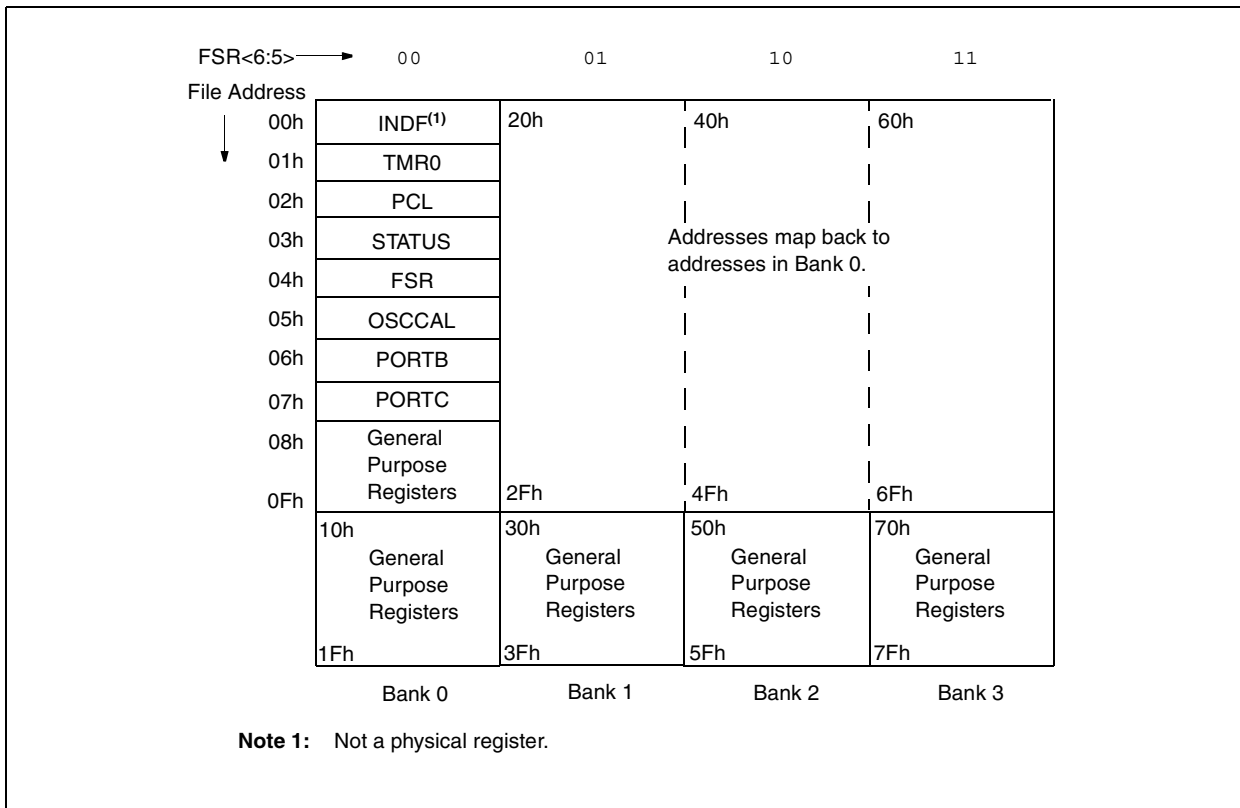
The General Purpose Registers are used for data and control information under command of the instructions.

For the PIC16C505, the register file is composed of 8 Special Function Registers, 24 General Purpose Registers and 48 General Purpose Registers that may be addressed using a banking scheme (Figure 4-2).

### 4.2.1 GENERAL PURPOSE REGISTER FILE

The General Purpose Register file is accessed, either directly or indirectly, through the File Select Register FSR (Section 4.8).

**FIGURE 4-2: PIC16C505 REGISTER FILE MAP**



## 4.2.2 SPECIAL FUNCTION REGISTERS

The Special Function Registers (SFRs) are registers used by the CPU and peripheral functions to control the operation of the device (Table 4-1).

The Special Function Registers can be classified into two sets. The Special Function Registers associated with the “core” functions are described in this section. Those related to the operation of the peripheral features are described in the section for each peripheral feature.

**TABLE 4-1: SPECIAL FUNCTION REGISTER (SFR) SUMMARY**

Address	Name	Bit 7	Bit 6	Bit 5	Bit 4	Bit 3	Bit 2	Bit 1	Bit 0	Value on Power-On Reset	Value on All Other Resets <sup>(2)</sup>
00h	INDF	Uses contents of FSR to address data memory (not a physical register)								xxxx xxxx	uuuu uuuu
01h	TMR0	8-bit real-time clock/counter								xxxx xxxx	uuuu uuuu
02h <sup>(1)</sup>	PCL	Low order 8 bits of PC								1111 1111	1111 1111
03h	STATUS	RBWUF	—	PAO	$\overline{TO}$	$\overline{PD}$	Z	DC	C	0001 1xxx	q00q quuu <sup>(1)</sup>
04h	FSR	Indirect data memory address pointer								110x xxxx	11uu uuuu
05h	OSCCAL	CAL5	CAL4	CAL3	CAL2	CAL1	CAL0	—	—	1000 00--	uuuu uu--
N/A	TRISB	—	—	I/O control registers						--11 1111	--11 1111
N/A	TRISC	—	—	I/O control registers						--11 1111	--11 1111
N/A	OPTION	$\overline{RBWU}$	$\overline{RBPU}$	TOCS	TOSE	PSA	PS2	PS1	PS0	1111 1111	1111 1111
06h	PORTB	—	—	RB5	RB4	RB3	RB2	RB1	RB0	--xx xxxx	--uu uuuu
07h	PORTC	—	—	RC5	RC4	RC3	RC2	RC1	RC0	--xx xxxx	--uu uuuu

Legend: Shaded cells not used by Port Registers, read as '0', — = unimplemented, read as '0', x = unknown, u = unchanged, q = depends on condition.

**Note 1:** If reset was due to wake-up on pin change, then bit 7 = 1. All other resets will cause bit 7 = 0.

**Note 2:** Other (non-power-up) resets include external reset through MCLR, watchdog timer and wake-up on pin change reset.



## 4.4 OPTION Register

The OPTION register is a 8-bit wide, write-only register, which contains various control bits to configure the Timer0/WDT prescaler and Timer0.

By executing the OPTION instruction, the contents of the W register will be transferred to the OPTION register. A RESET sets the OPTION<7:0> bits.

**Note:** If TRIS bit is set to '0', the wake-up on change and pull-up functions are disabled for that pin (i.e., note that TRIS overrides OPTION control of  $\overline{\text{RBPU}}$  and  $\overline{\text{RBWU}}$ ).

### REGISTER 4-2: OPTION REGISTER

	W-1	W-1	W-1	W-1	W-1	W-1	W-1	W-1	
	$\overline{\text{RBWU}}$	$\overline{\text{RBPU}}$	T0CS	T0SE	PSA	PS2	PS1	PS0	
bit7	6	5	4	3	2	1			bit0

R = Readable bit  
 W = Writable bit  
 U = Unimplemented bit, read as '0'  
 - n = Value at POR reset

bit 7:  **$\overline{\text{RBWU}}$** : Enable wake-up on pin change (RB0, RB1, RB3, RB4)  
 1 = Disabled  
 0 = Enabled

bit 6:  **$\overline{\text{RBPU}}$** : Enable weak pull-ups (RB0, RB1, RB3, RB4)  
 1 = Disabled  
 0 = Enabled

bit 5: **T0CS**: Timer0 clock source select bit  
 1 = Transition on T0CKI pin (overrides TRIS <RC57>  
 0 = Transition on internal instruction cycle clock, Fosc/4

bit 4: **T0SE**: Timer0 source edge select bit  
 1 = Increment on high to low transition on the T0CKI pin  
 0 = Increment on low to high transition on the T0CKI pin

bit 3: **PSA**: Prescaler assignment bit  
 1 = Prescaler assigned to the WDT  
 0 = Prescaler assigned to Timer0

bit 2-0: **PS<2:0>**: Prescaler rate select bits

Bit Value	Timer0 Rate	WDT Rate
000	1 : 2	1 : 1
001	1 : 4	1 : 2
010	1 : 8	1 : 4
011	1 : 16	1 : 8
100	1 : 32	1 : 16
101	1 : 64	1 : 32
110	1 : 128	1 : 64
111	1 : 256	1 : 128

# PIC16C505

## 4.5 OSCCAL Register

The Oscillator Calibration (OSCCAL) register is used to calibrate the internal 4 MHz oscillator. It contains six bits for calibration

**Note:** Please note that erasing the device will also erase the pre-programmed internal calibration value for the internal oscillator. The calibration value must be read prior to erasing the part, so it can be reprogrammed correctly later.

After you move in the calibration constant, do not change the value. See Section 7.2.5

### REGISTER 4-3: OSCCAL REGISTER (ADDRESS 05h) PIC16C505

R/W-1	R/W-0	R/W-0	R/W-0	R/W-0	R/W-0	U-0	U-0
CAL5	CAL4	CAL3	CAL2	CAL1	CAL0	—	—

bit7 bit0

bit 7-2: **CAL<5:0>**: Calibration  
bit 1-0: Unimplemented read as '0'

R = Readable bit  
W = Writable bit  
U = Unimplemented bit,  
read as '0'  
- n = Value at POR reset

## 4.6 Program Counter

As a program instruction is executed, the Program Counter (PC) will contain the address of the next program instruction to be executed. The PC value is increased by one every instruction cycle, unless an instruction changes the PC.

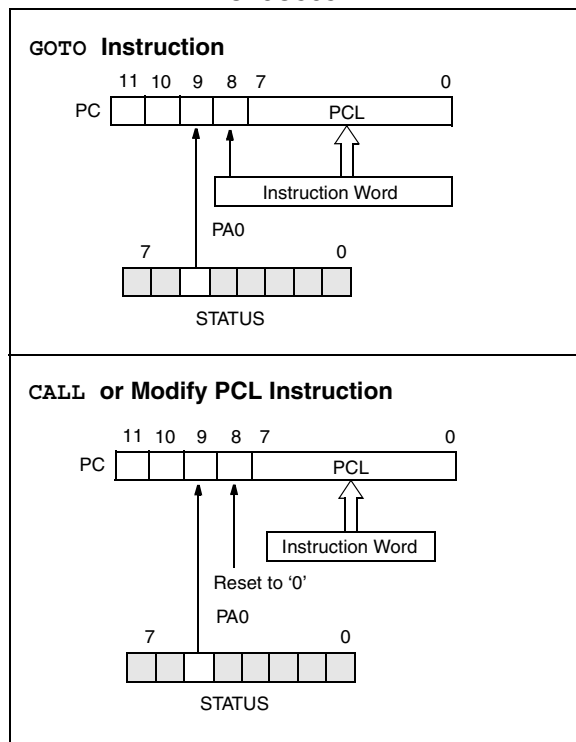
For a `GOTO` instruction, bits 8:0 of the PC are provided by the `GOTO` instruction word. The PC Latch (PCL) is mapped to `PC<7:0>`. Bit 5 of the `STATUS` register provides page information to bit 9 of the PC (Figure 4-3).

For a `CALL` instruction, or any instruction where the PCL is the destination, bits 7:0 of the PC again are provided by the instruction word. However, `PC<8>` does not come from the instruction word, but is always cleared (Figure 4-3).

Instructions where the PCL is the destination, or Modify PCL instructions, include `MOVWF PC`, `ADDWF PC`, and `BSF PC, 5`.

**Note:** Because `PC<8>` is cleared in the `CALL` instruction or any Modify PCL instruction, all subroutine calls or computed jumps are limited to the first 256 locations of any program memory page (512 words long).

**FIGURE 4-3: LOADING OF PC BRANCH INSTRUCTIONS - PIC16C505**



### 4.6.1 EFFECTS OF RESET

The Program Counter is set upon a `RESET`, which means that the PC addresses the last location in the last page (i.e., the oscillator calibration instruction.) After executing `MOVLW XX`, the PC will roll over to location 00h and begin executing user code.

The `STATUS` register page preselect bits are cleared upon a `RESET`, which means that page 0 is preselected.

Therefore, upon a `RESET`, a `GOTO` instruction will automatically cause the program to jump to page 0 until the value of the page bits is altered.

## 4.7 Stack

PIC16C505 devices have a 12-bit wide hardware push/pop stack.

A `CALL` instruction will push the current value of stack 1 into stack 2 and then push the current program counter value, incremented by one, into stack level 1. If more than two sequential `CALL`'s are executed, only the most recent two return addresses are stored.

A `RETLW` instruction will pop the contents of stack level 1 into the program counter and then copy stack level 2 contents into level 1. If more than two sequential `RETLW`'s are executed, the stack will be filled with the address previously stored in level 2. Note that the `W` register will be loaded with the literal value specified in the instruction. This is particularly useful for the implementation of data look-up tables within the program memory.

**Note 1:** There are no `STATUS` bits to indicate stack overflows or stack underflow conditions.

**Note 2:** There are no instructions mnemonics called `PUSH` or `POP`. These are actions that occur from the execution of the `CALL`, `RETLW`, and instructions.

# PIC16C505

## 4.8 Indirect Data Addressing: INDF and FSR Registers

The INDF register is not a physical register. Addressing INDF actually addresses the register whose address is contained in the FSR register (FSR is a *pointer*). This is indirect addressing.

### EXAMPLE 4-1: INDIRECT ADDRESSING

- Register file 07 contains the value 10h
- Register file 08 contains the value 0Ah
- Load the value 07 into the FSR register
- A read of the INDF register will return the value of 10h
- Increment the value of the FSR register by one (FSR = 08)
- A read of the INDR register now will return the value of 0Ah.

Reading INDF itself indirectly (FSR = 0) will produce 00h. Writing to the INDF register indirectly results in a no-operation (although STATUS bits may be affected).

A simple program to clear RAM locations 10h-1Fh using indirect addressing is shown in Example 4-2.

### EXAMPLE 4-2: HOW TO CLEAR RAM USING INDIRECT ADDRESSING

```

movlw 0x10 ;initialize pointer
movwf FSR ; to RAM
NEXT   clr  INDF ;clear INDF register
       incf FSR,F ;inc pointer
       btfsc FSR,4 ;all done?
       goto NEXT ;NO, clear next

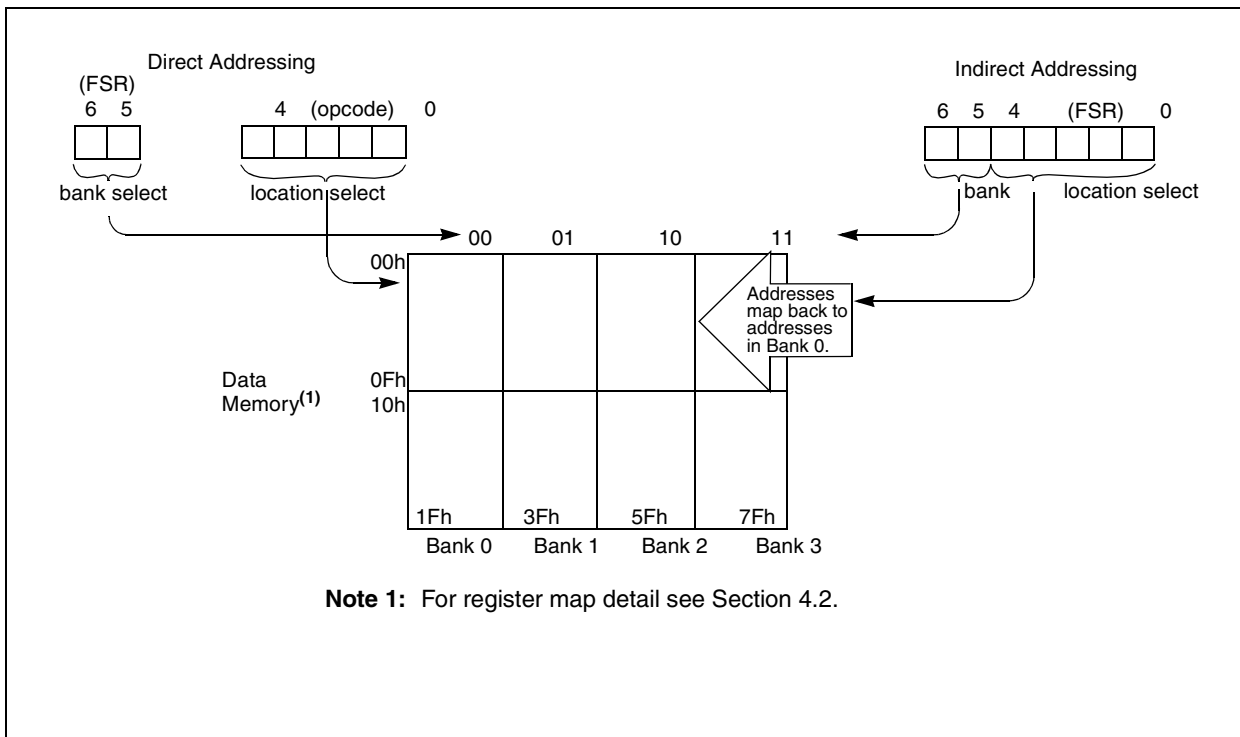
CONTINUE
      : ;YES, continue
      :
```

The FSR is a 5-bit wide register. It is used in conjunction with the INDF register to indirectly address the data memory area.

The FSR<4:0> bits are used to select data memory addresses 00h to 1Fh.

The device uses FSR<6:5> to select between banks 0:3.

FIGURE 4-4: DIRECT/INDIRECT ADDRESSING



## 5.0 I/O PORT

As with any other register, the I/O register can be written and read under program control. However, read instructions (e.g., `MOVF PORTB, W`) always read the I/O pins independent of the pin's input/output modes. On RESET, all I/O ports are defined as input (inputs are at hi-impedance) since the I/O control registers are all set.

### 5.1 PORTB

PORTB is an 8-bit I/O register. Only the low order 6 bits are used ( $RB<5:0>$ ). Bits 7 and 6 are unimplemented and read as '0's. Please note that RB3 is an input only pin. The configuration word can set several I/O's to alternate functions. When acting as alternate functions, the pins will read as '0' during port read. Pins RB0, RB1, RB3 and RB4 can be configured with weak pull-ups and also with wake-up on change. The wake-up on change and weak pull-up functions are not pin selectable. If pin 4 is configured as MCLR, weak pull-up is always off and wake-up on change for this pin is not enabled.

### 5.2 PORTC

PORTC is an 8-bit I/O register. Only the low order 6 bits are used ( $RC<5:0>$ ). Bits 7 and 6 are unimplemented and read as '0's.

### 5.3 TRIS Registers

The output driver control register is loaded with the contents of the W register by executing the `TRIS f` instruction. A '1' from a TRIS register bit puts the corresponding output driver in a hi-impedance mode. A '0' puts the contents of the output data latch on the selected pins, enabling the output buffer. The exceptions are RB3, which is input only, and RC5, which may be controlled by the option register. See Register 4-2.

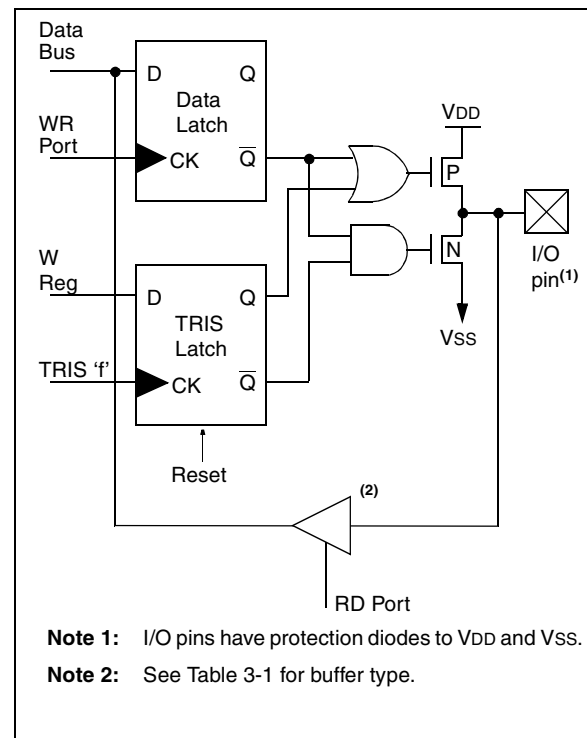
**Note:** A read of the ports reads the pins, not the output data latches. That is, if an output driver on a pin is enabled and driven high, but the external system is holding it low, a read of the port will indicate that the pin is low.

The TRIS registers are "write-only" and are set (output drivers disabled) upon RESET.

## 5.4 I/O Interfacing

The equivalent circuit for an I/O port pin is shown in Figure 5-1. All port pins except RB3, which is input only, may be used for both input and output operations. For input operations, these ports are non-latching. Any input must be present until read by an input instruction (e.g., `MOVF PORTB, W`). The outputs are latched and remain unchanged until the output latch is rewritten. To use a port pin as output, the corresponding direction control bit in TRIS must be cleared (= 0). For use as an input, the corresponding TRIS bit must be set. Any I/O pin (except RB3) can be programmed individually as input or output.

**FIGURE 5-1: EQUIVALENT CIRCUIT FOR A SINGLE I/O PIN**



**TABLE 5-1: SUMMARY OF PORT REGISTERS**

Address	Name	Bit 7	Bit 6	Bit 5	Bit 4	Bit 3	Bit 2	Bit 1	Bit 0	Value on Power-On Reset	Value on All Other Resets
N/A	TRISB	—	—	I/O control registers						--11 1111	--11 1111
N/A	TRISC	—	—	I/O control registers						--11 1111	--11 1111
N/A	OPTION	$\overline{\text{RBWU}}$	$\overline{\text{RBPU}}$	TOCS	TOSE	PSA	PS2	PS1	PS0	1111 1111	1111 1111
03h	STATUS	RBWUF	—	PAO	$\overline{\text{TO}}$	$\overline{\text{PD}}$	Z	DC	C	0001 1xxx	q00q quuu <sup>(1)</sup>
06h	PORTB	—	—	RB5	RB4	RB3	RB2	RB1	RB0	--xx xxxx	--uu uuuu
07h	PORTC	—	—	RC5	RC4	RC3	RC2	RC1	RC0	--xx xxxx	--uu uuuu

Legend: Shaded cells not used by Port Registers, read as '0', — = unimplemented, read as '0', x = unknown, u = unchanged, q = depends on condition.

**Note 1:** If reset was due to wake-up on pin change, then bit 7 = 1. All other resets will cause bit 7 = 0.

## 5.5 I/O Programming Considerations

### 5.5.1 BI-DIRECTIONAL I/O PORTS

Some instructions operate internally as read followed by write operations. The BCF and BSF instructions, for example, read the entire port into the CPU, execute the bit operation and re-write the result. Caution must be used when these instructions are applied to a port where one or more pins are used as input/outputs. For example, a BSF operation on bit5 of PORTB will cause all eight bits of PORTB to be read into the CPU, bit5 to be set and the PORTB value to be written to the output latches. If another bit of PORTB is used as a bi-directional I/O pin (say bit0) and it is defined as an input at this time, the input signal present on the pin itself would be read into the CPU and rewritten to the data latch of this particular pin, overwriting the previous content. As long as the pin stays in the input mode, no problem occurs. However, if bit0 is switched into output mode later on, the content of the data latch may now be unknown.

Example 5-1 shows the effect of two sequential read-modify-write instructions (e.g., BCF, BSF, etc.) on an I/O port.

A pin actively outputting a high or a low should not be driven from external devices at the same time in order to change the level on this pin (“wired-or”, “wired-and”). The resulting high output currents may damage the chip.

### EXAMPLE 5-1: READ-MODIFY-WRITE INSTRUCTIONS ON AN I/O PORT

```

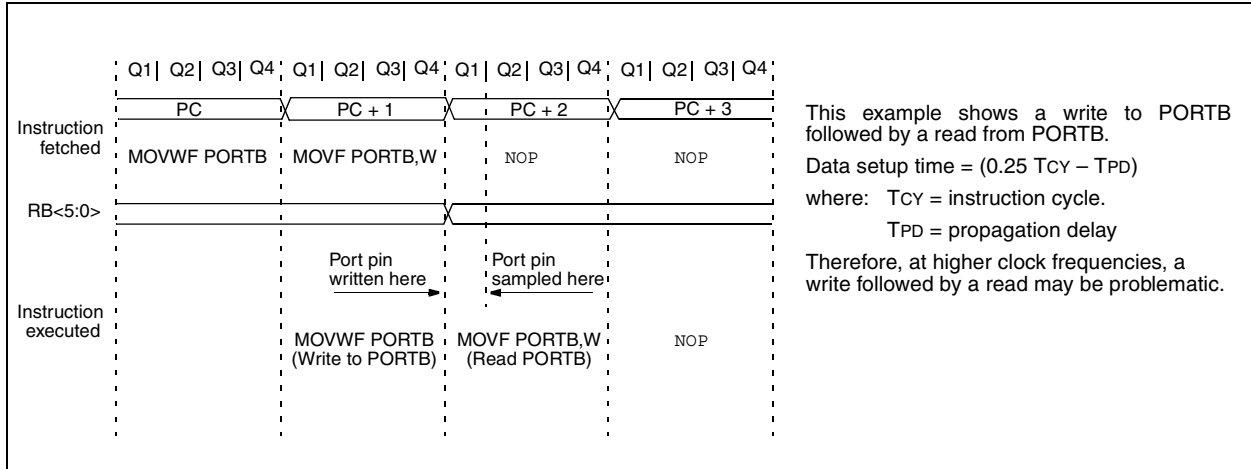
;Initial PORTB Settings
; PORTB<5:3> Inputs
; PORTB<2:0> Outputs
;
;
;          PORTB latch  PORTB pins
;          -----  -----
BCF  PORTB, 5      ;--01 -ppp  --11 pppp
BCF  PORTB, 4      ;--10 -ppp  --11 pppp
MOVLW 007h        ;
TRIS  PORTB        ;--10 -ppp  --11 pppp
;
;Note that the user may have expected the pin
;values to be --00 pppp. The 2nd BCF caused
;RB5 to be latched as the pin value (High).

```

### 5.5.2 SUCCESSIVE OPERATIONS ON I/O PORTS

The actual write to an I/O port happens at the end of an instruction cycle, whereas for reading, the data must be valid at the beginning of the instruction cycle (Figure 5-2). Therefore, care must be exercised if a write followed by a read operation is carried out on the same I/O port. The sequence of instructions should allow the pin voltage to stabilize (load dependent) before the next instruction causes that file to be read into the CPU. Otherwise, the previous state of that pin may be read into the CPU rather than the new state. When in doubt, it is better to separate these instructions with a NOP or another instruction not accessing this I/O port.

**FIGURE 5-2: SUCCESSIVE I/O OPERATION**



# PIC16C505

---

NOTES:

## 6.0 TIMER0 MODULE AND TMR0 REGISTER

The Timer0 module has the following features:

- 8-bit timer/counter register, TMR0
  - Readable and writable
- 8-bit software programmable prescaler
- Internal or external clock select
  - Edge select for external clock

Figure 6-1 is a simplified block diagram of the Timer0 module.

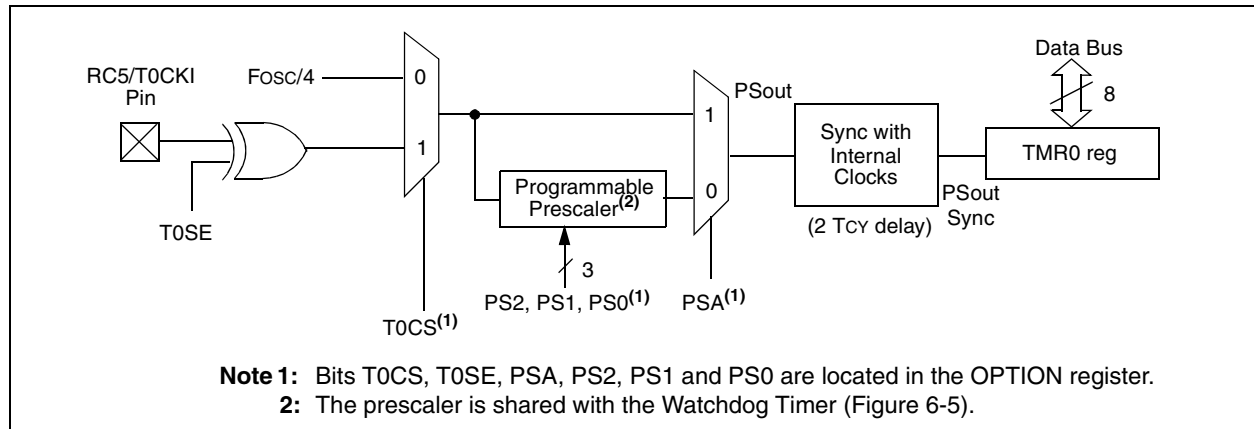
Timer mode is selected by clearing the T0CS bit (OPTION<5>). In timer mode, the Timer0 module will increment every instruction cycle (without prescaler). If TMR0 register is written, the increment is inhibited for the following two cycles (Figure 6-2 and Figure 6-3). The user can work around this by writing an adjusted value to the TMR0 register.

Counter mode is selected by setting the T0CS bit (OPTION<5>). In this mode, Timer0 will increment either on every rising or falling edge of pin T0CKI. The T0SE bit (OPTION<4>) determines the source edge. Clearing the T0SE bit selects the rising edge. Restrictions on the external clock input are discussed in detail in Section 6.1.

The prescaler may be used by either the Timer0 module or the Watchdog Timer, but not both. The prescaler assignment is controlled in software by the control bit PSA (OPTION<3>). Clearing the PSA bit will assign the prescaler to Timer0. The prescaler is not readable or writable. When the prescaler is assigned to the Timer0 module, prescale values of 1:2, 1:4, ..., 1:256 are selectable. Section 6.2 details the operation of the prescaler.

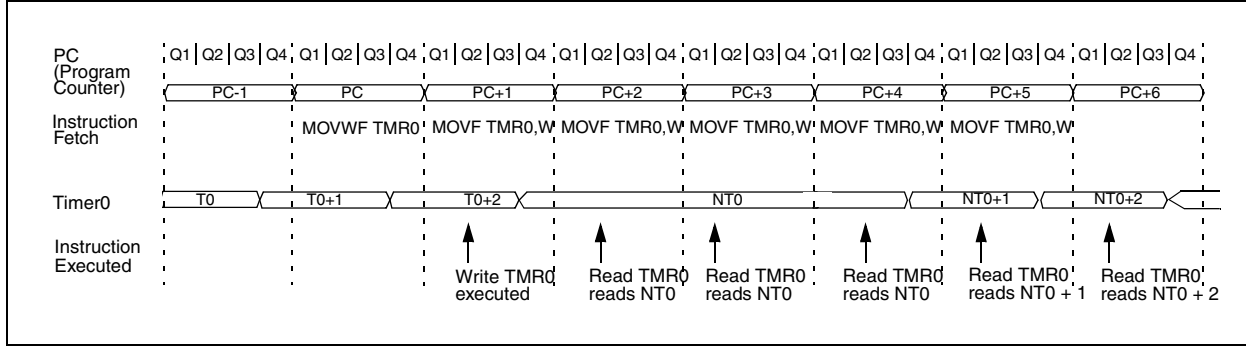
A summary of registers associated with the Timer0 module is found in Table 6-1.

**FIGURE 6-1: TIMER0 BLOCK DIAGRAM**

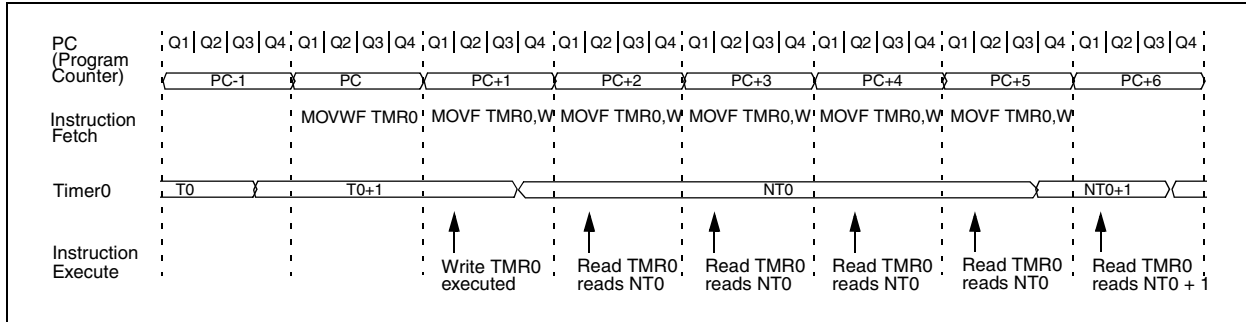


# PIC16C505

**FIGURE 6-2: TIMER0 TIMING: INTERNAL CLOCK/NO PRESCALE**



**FIGURE 6-3: TIMER0 TIMING: INTERNAL CLOCK/PRESCALE 1:2**



**TABLE 6-1: REGISTERS ASSOCIATED WITH TIMER0**

Address	Name	Bit 7	Bit 6	Bit 5	Bit 4	Bit 3	Bit 2	Bit 1	Bit 0	Value on Power-On Reset	Value on All Other Resets
01h	TMR0	Timer0 - 8-bit real-time clock/counter								xxxx xxxx	uuuu uuuu
N/A	OPTION	$\overline{\text{RBW}}$	$\overline{\text{RBP}}$	T0CS	T0SE	PSA	PS2	PS1	PS0	1111 1111	1111 1111
N/A	TRISC	—	—	RC5	RC4	RC3	RC2	RC1	RC0	--11 1111	--11 1111

Legend: Shaded cells not used by Timer0, - = unimplemented, x = unknown, u = unchanged.

## 6.1 Using Timer0 with an External Clock

When an external clock input is used for Timer0, it must meet certain requirements. The external clock requirement is due to internal phase clock (TOSC) synchronization. Also, there is a delay in the actual incrementing of Timer0 after synchronization.

### 6.1.1 EXTERNAL CLOCK SYNCHRONIZATION

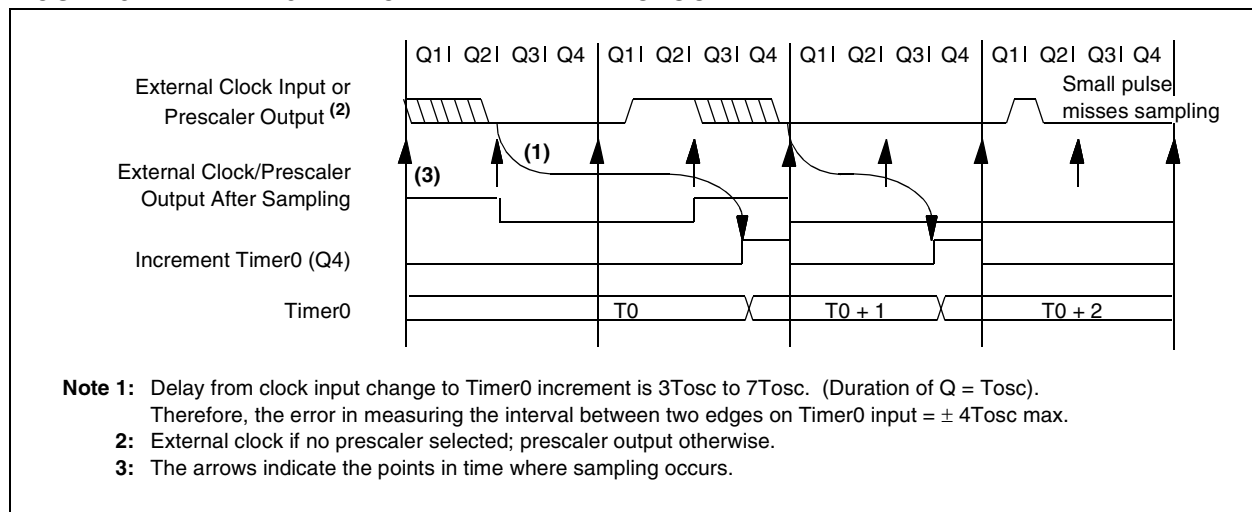
When no prescaler is used, the external clock input is the same as the prescaler output. The synchronization of T0CKI with the internal phase clocks is accomplished by sampling the prescaler output on the Q2 and Q4 cycles of the internal phase clocks (Figure 6-4). Therefore, it is necessary for T0CKI to be high for at least 2TOSC (and a small RC delay of 20 ns) and low for at least 2TOSC (and a small RC delay of 20 ns). Refer to the electrical specification of the desired device.

When a prescaler is used, the external clock input is divided by the asynchronous ripple counter-type prescaler, so that the prescaler output is symmetrical. For the external clock to meet the sampling requirement, the ripple counter must be taken into account. Therefore, it is necessary for T0CKI to have a period of at least 4TOSC (and a small RC delay of 40 ns) divided by the prescaler value. The only requirement on T0CKI high and low time is that they do not violate the minimum pulse width requirement of 10 ns. Refer to parameters 40, 41 and 42 in the electrical specification of the desired device.

### 6.1.2 TIMER0 INCREMENT DELAY

Since the prescaler output is synchronized with the internal clocks, there is a small delay from the time the external clock edge occurs to the time the Timer0 module is actually incremented. Figure 6-4 shows the delay from the external clock edge to the timer incrementing.

**FIGURE 6-4: TIMER0 TIMING WITH EXTERNAL CLOCK**



# PIC16C505

## 6.2 Prescaler

An 8-bit counter is available as a prescaler for the Timer0 module or as a postscaler for the Watchdog Timer (WDT), respectively (Section 7.6). For simplicity, this counter is being referred to as “prescaler” throughout this data sheet. Note that the prescaler may be used by either the Timer0 module or the WDT, but not both. Thus, a prescaler assignment for the Timer0 module means that there is no prescaler for the WDT, and vice-versa.

The PSA and PS<2:0> bits (OPTION<3:0>) determine prescaler assignment and prescale ratio.

When assigned to the Timer0 module, all instructions writing to the TMR0 register (e.g., CLRF 1, MOVWF 1, BSF 1,x, etc.) will clear the prescaler. When assigned to WDT, a CLRWDT instruction will clear the prescaler along with the WDT. The prescaler is neither readable nor writable. On a RESET, the prescaler contains all '0's.

### 6.2.1 SWITCHING PRESCALER ASSIGNMENT

The prescaler assignment is fully under software control (i.e., it can be changed “on-the-fly” during program execution). To avoid an unintended device

RESET, the following instruction sequence (Example 6-1) must be executed when changing the prescaler assignment from Timer0 to the WDT.

#### EXAMPLE 6-1: CHANGING PRESCALER (TIMER0→WDT)

```

1. CLRWDT           ;Clear WDT
2. CLRF  TMR0      ;Clear TMR0 & Prescaler
3. MOVLW '00xx1111'b ;These 3 lines (5, 6, 7)
4. OPTION          ; are required only if
                   ; desired
5. CLRWDT          ;PS<2:0> are 000 or 001
6. MOVLW '00xx1xxx'b ;Set Postscaler to
7. OPTION          ; desired WDT rate
    
```

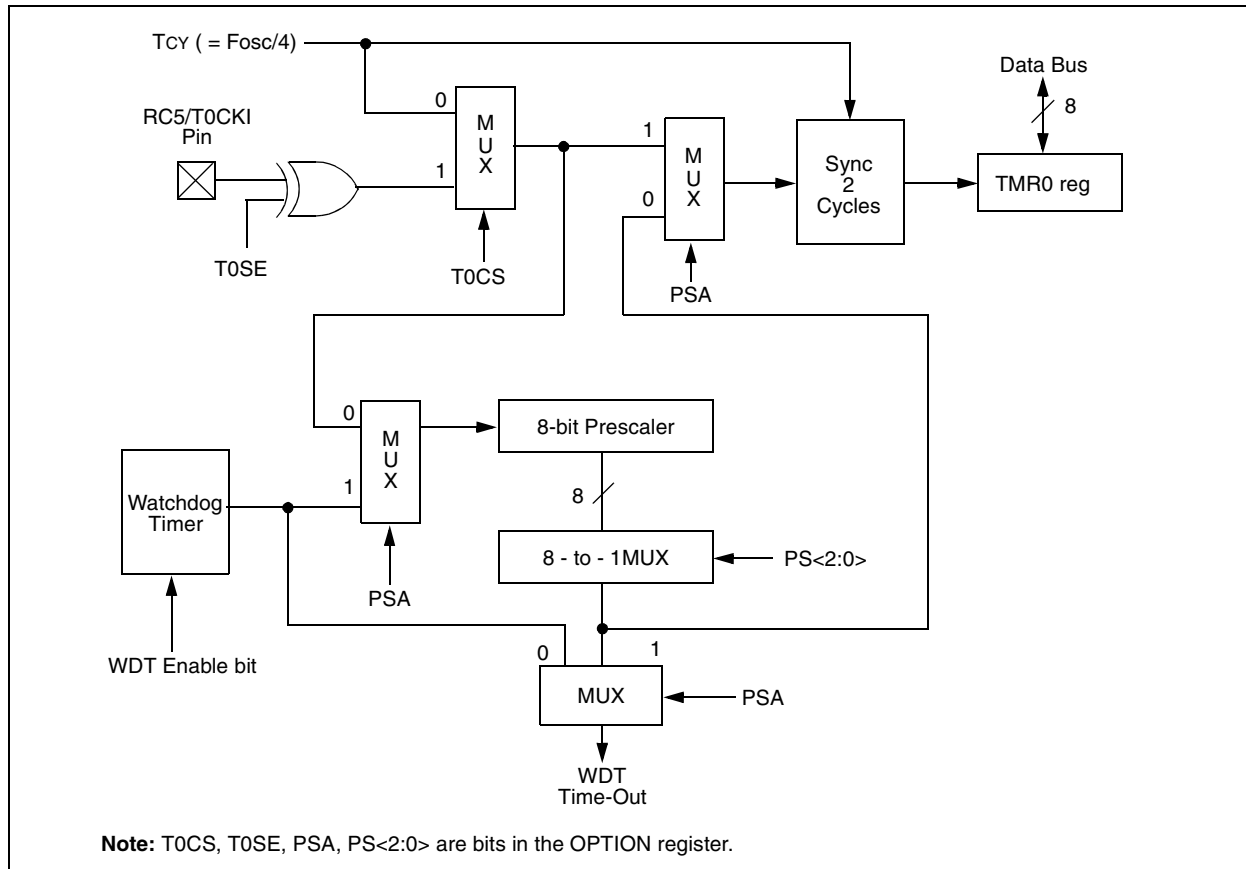
To change prescaler from the WDT to the Timer0 module, use the sequence shown in Example 6-2. This sequence must be used even if the WDT is disabled. A CLRWDT instruction should be executed before switching the prescaler.

#### EXAMPLE 6-2: CHANGING PRESCALER (WDT→TIMER0)

```

CLRWDT           ;Clear WDT and
                ;prescaler
MOVLW 'xxxx0xxx' ;Select TMR0, new
                ;prescale value and
                ;clock source
OPTION
    
```

FIGURE 6-5: BLOCK DIAGRAM OF THE TIMER0/WDT PRESCALER



## 7.0 SPECIAL FEATURES OF THE CPU

What sets a microcontroller apart from other processors are special circuits to deal with the needs of real-time applications. The PIC16C505 microcontroller has a host of such features intended to maximize system reliability, minimize cost through elimination of external components, provide power saving operating modes and offer code protection. These features are:

- Oscillator selection
- Reset
  - Power-On Reset (POR)
  - Device Reset Timer (DRT)
  - Wake-up from SLEEP on pin change
- Watchdog Timer (WDT)
- SLEEP
- Code protection
- ID locations
- In-circuit Serial Programming
- Clock Out

The PIC16C505 has a Watchdog Timer, which can be shut off only through configuration bit WDTE. It runs off of its own RC oscillator for added reliability. If using HS, XT or LP selectable oscillator options, there is always an 18 ms (nominal) delay provided by the Device Reset Timer (DRT), intended to keep the chip in reset until the crystal oscillator is stable. If using INTRC or EXTRC, there is an 18 ms delay only on VDD power-up. With this timer on-chip, most applications need no external reset circuitry.

The SLEEP mode is designed to offer a very low current power-down mode. The user can wake-up from SLEEP through a change on input pins or through a Watchdog Timer time-out. Several oscillator options are also made available to allow the part to fit the application, including an internal 4 MHz oscillator. The EXTRC oscillator option saves system cost while the LP crystal option saves power. A set of configuration bits are used to select various options.

### 7.1 Configuration Bits

The PIC16C505 configuration word consists of 12 bits. Configuration bits can be programmed to select various device configurations. Three bits are for the selection of the oscillator type, one bit is the Watchdog Timer enable bit, and one bit is the  $\overline{\text{MCLR}}$  enable bit. Seven bits are for code protection (Register 7-1).

**REGISTER 7-1: CONFIGURATION WORD FOR PIC16C505**

CP	CP	CP	CP	CP	CP	MCLR $\overline{\text{E}}$	CP	WDTE	FOSC2	FOSC1	FOSC0	Register: CONFIG
bit11	10	9	8	7	6	5	4	3	2	1	bit0	Address <sup>(2)</sup> : 0FFFh
bit 11-6, 4: <b>CP Code Protection bits</b> <sup>(1)(2)(3)</sup>												
bit 5: <b>MCLR<math>\overline{\text{E}}</math></b> : RB3/ $\overline{\text{MCLR}}$ pin function select 1 = RB3/ $\overline{\text{MCLR}}$ pin function is $\overline{\text{MCLR}}$ 0 = RB3/ $\overline{\text{MCLR}}$ pin function is digital I/O, $\overline{\text{MCLR}}$ internally tied to VDD												
bit 3: <b>WDTE</b> : Watchdog timer enable bit 1 = WDT enabled 0 = WDT disabled												
bit 2-0: <b>FOSC&lt;1:0&gt;</b> : Oscillator Selection bits 111 = external RC oscillator/CLKOUT function on RB4/OSC2/CLKOUT pin 110 = external RC oscillator/RB4 function on RB4/OSC2/CLKOUT pin 101 = internal RC oscillator/CLKOUT function on RB4/OSC2/CLKOUT pin 100 = internal RC oscillator/RB4 function on RB4/OSC2/CLKOUT pin 011 = invalid selection 010 = HS oscillator 001 = XT oscillator 000 = LP oscillator												
<b>Note 1:</b> 03FFh is always uncode protected on the PIC16C505. This location contains the MOV $\text{LWxx}$ calibration instruction for the INTRC.												
<b>2:</b> Refer to the PIC16C505 Programming Specifications to determine how to access the configuration word. This register is not user addressable during device operation.												
<b>3:</b> All code protect bits must be written to the same value.												

# PIC16C505

## 7.2 Oscillator Configurations

### 7.2.1 OSCILLATOR TYPES

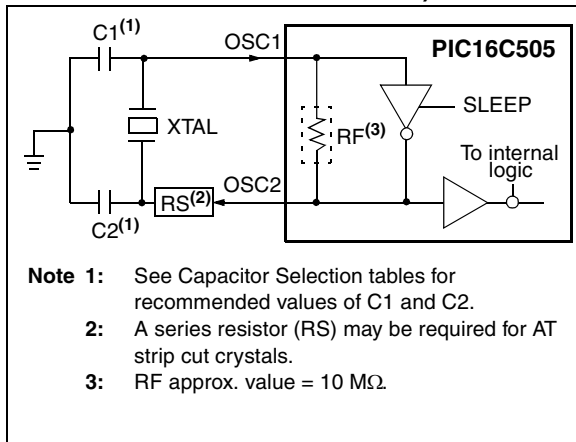
The PIC16C505 can be operated in four different oscillator modes. The user can program three configuration bits (FOSC<2:0>) to select one of these four modes:

- LP: Low Power Crystal
- XT: Crystal/Resonator
- HS: High Speed Crystal/Resonator
- INTRC: Internal 4 MHz Oscillator
- EXTRC: External Resistor/Capacitor

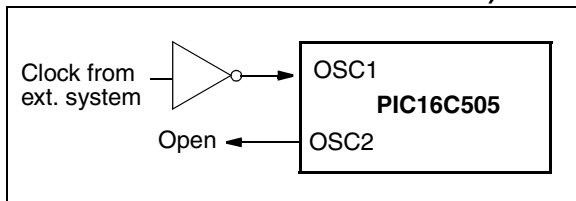
### 7.2.2 CRYSTAL OSCILLATOR / CERAMIC RESONATORS

In HS, XT or LP modes, a crystal or ceramic resonator is connected to the RB5/OSC1/CLKIN and RB4/OSC2/CLKOUT pins to establish oscillation (Figure 7-1). The PIC16C505 oscillator design requires the use of a parallel cut crystal. Use of a series cut crystal may give a frequency out of the crystal manufacturers specifications. When in HS, XT or LP modes, the device can have an external clock source drive the RB5/OSC1/CLKIN pin (Figure 7-2).

**FIGURE 7-1: CRYSTAL OPERATION (OR CERAMIC RESONATOR) (HS, XT OR LP OSC CONFIGURATION)**



**FIGURE 7-2: EXTERNAL CLOCK INPUT OPERATION (HS, XT OR LP OSC CONFIGURATION)**



**TABLE 7-1: CAPACITOR SELECTION FOR CERAMIC RESONATORS - PIC16C505**

Osc Type	Resonator Freq	Cap. Range C1	Cap. Range C2
XT	4.0 MHz	30 pF	30 pF
HS	16 MHz	10-47 pF	10-47 pF

These values are for design guidance only. Since each resonator has its own characteristics, the user should consult the resonator manufacturer for appropriate values of external components.

**TABLE 7-2: CAPACITOR SELECTION FOR CRYSTAL OSCILLATOR - PIC16C505**

Osc Type	Resonator Freq	Cap. Range C1	Cap. Range C2
LP	32 kHz <sup>(1)</sup>	15 pF	15 pF
XT	200 kHz	47-68 pF	47-68 pF
	1 MHz	15 pF	15 pF
	4 MHz	15 pF	15 pF
HS	20 MHz	15-47 pF	15-47 pF

**Note 1:** For VDD > 4.5V, C1 = C2 ≈ 30 pF is recommended.

These values are for design guidance only. Rs may be required to avoid overdriving crystals with low drive level specification. Since each crystal has its own characteristics, the user should consult the crystal manufacturer for appropriate values of external components.

## 7.2.3 EXTERNAL CRYSTAL OSCILLATOR CIRCUIT

Either a prepackaged oscillator or a simple oscillator circuit with TTL gates can be used as an external crystal oscillator circuit. Prepackaged oscillators provide a wide operating range and better stability. A well-designed crystal oscillator will provide good performance with TTL gates. Two types of crystal oscillator circuits can be used: one with parallel resonance, or one with series resonance.

Figure 7-3 shows implementation of a parallel resonant oscillator circuit. The circuit is designed to use the fundamental frequency of the crystal. The 74AS04 inverter performs the 180-degree phase shift that a parallel oscillator requires. The 4.7 k $\Omega$  resistor provides the negative feedback for stability. The 10 k $\Omega$  potentiometers bias the 74AS04 in the linear region. This circuit could be used for external oscillator designs.

**FIGURE 7-3: EXTERNAL PARALLEL RESONANT CRYSTAL OSCILLATOR CIRCUIT**

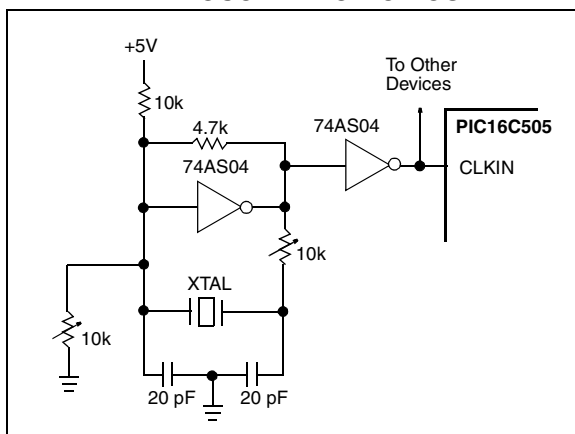
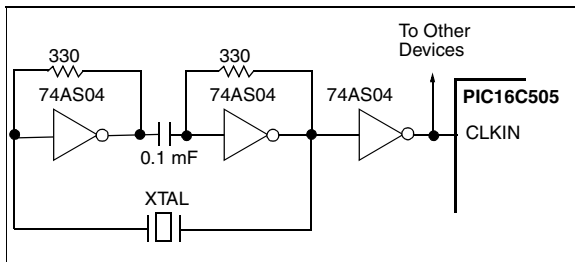


Figure 7-4 shows a series resonant oscillator circuit. This circuit is also designed to use the fundamental frequency of the crystal. The inverter performs a 180-degree phase shift in a series resonant oscillator circuit. The 330  $\Omega$  resistors provide the negative feedback to bias the inverters in their linear region.

**FIGURE 7-4: EXTERNAL SERIES RESONANT CRYSTAL OSCILLATOR CIRCUIT**



## 7.2.4 EXTERNAL RC OSCILLATOR

For timing insensitive applications, the RC device option offers additional cost savings. The RC oscillator frequency is a function of the supply voltage, the resistor ( $R_{ext}$ ) and capacitor ( $C_{ext}$ ) values, and the operating temperature. In addition to this, the oscillator frequency will vary from unit to unit due to normal process parameter variation. Furthermore, the difference in lead frame capacitance between package types will also affect the oscillation frequency, especially for low  $C_{ext}$  values. The user also needs to take into account variation due to tolerance of external R and C components used.

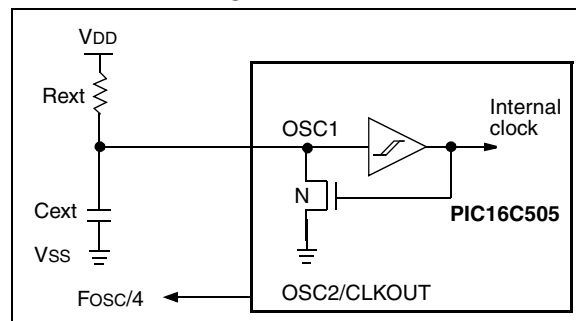
Figure 7-5 shows how the R/C combination is connected to the PIC16C505. For  $R_{ext}$  values below 2.2 k $\Omega$ , the oscillator operation may become unstable, or stop completely. For very high  $R_{ext}$  values (e.g., 1 M $\Omega$ ) the oscillator becomes sensitive to noise, humidity and leakage. Thus, we recommend keeping  $R_{ext}$  between 3 k $\Omega$  and 100 k $\Omega$ .

Although the oscillator will operate with no external capacitor ( $C_{ext} = 0$  pF), we recommend using values above 20 pF for noise and stability reasons. With no or small external capacitance, the oscillation frequency can vary dramatically due to changes in external capacitances, such as PCB trace capacitance or package lead frame capacitance.

The Electrical Specifications section shows RC frequency variation from part to part due to normal process variation. The variation is larger for larger values of R (since leakage current variation will affect RC frequency more for large R) and for smaller values of C (since variation of input capacitance will affect RC frequency more).

Also, see the Electrical Specifications section for variation of oscillator frequency due to  $V_{DD}$  for given  $R_{ext}/C_{ext}$  values, as well as frequency variation due to operating temperature for given R, C and  $V_{DD}$  values.

**FIGURE 7-5: EXTERNAL RC OSCILLATOR MODE**



# PIC16C505

---

## 7.2.5 INTERNAL 4 MHz RC OSCILLATOR

The internal RC oscillator provides a fixed 4 MHz (nominal) system clock at  $V_{DD} = 5V$  and  $25^{\circ}C$ , see Electrical Specifications section for information on variation over voltage and temperature.

In addition, a calibration instruction is programmed into the last address of memory, which contains the calibration value for the internal RC oscillator. This location is always protected, regardless of the code protect settings. This value is programmed as a `MOVLW XX` instruction where `XX` is the calibration value, and is placed at the reset vector. This will load the `W` register with the calibration value upon reset and the PC will then roll over to the users program at address `0x000`. The user then has the option of writing the value to the `OSCCAL` Register (`05h`) or ignoring it.

`OSCCAL`, when written to with the calibration value, will “trim” the internal oscillator to remove process variation from the oscillator frequency.

<p><b>Note:</b> Please note that erasing the device will also erase the pre-programmed internal calibration value for the internal oscillator. The calibration value must be read prior to erasing the part so it can be reprogrammed correctly later.</p>
--

For the PIC16C505, only bits `<7:2>` of `OSCCAL` are implemented.

## 7.3 RESET

The device differentiates between various kinds of reset:

- a) Power on reset (POR)
- b)  $\overline{MCLR}$  reset during normal operation
- c)  $\overline{MCLR}$  reset during SLEEP
- d) WDT time-out reset during normal operation
- e) WDT time-out reset during SLEEP
- f) Wake-up from SLEEP on pin change

Some registers are not reset in any way, they are unknown on POR and unchanged in any other reset. Most other registers are reset to “reset state” on power-on reset (POR),  $\overline{MCLR}$ , WDT or wake-up on pin change reset during normal operation. They are not affected by a WDT reset during SLEEP or  $\overline{MCLR}$  reset during SLEEP, since these resets are viewed as resumption of normal operation. The exceptions to this are `TO`, `PD` and `RBWUF` bits. They are set or cleared differently in different reset situations. These bits are used in software to determine the nature of reset. See Table 7-3 for a full description of reset states of all registers.

**TABLE 7-3: RESET CONDITIONS FOR REGISTERS**

Register	Address	Power-on Reset	MCLR Reset WDT time-out Wake-up on Pin Change
W	—	qqqq qqqq <sup>(1)</sup>	qqqq qqqq <sup>(1)</sup>
INDF	00h	xxxx xxxx	uuuu uuuu
TMR0	01h	xxxx xxxx	uuuu uuuu
PC	02h	1111 1111	1111 1111
STATUS	03h	0001 1xxx	q00q quuu <sup>(2,3)</sup>
FSR	04h	110x xxxx	11uu uuuu
OSCCAL	05h	1000 00--	uuuu uu--
PORTB	06h	--xx xxxxxx	--uu uuuu
PORTC	07h	--xx xxxxxx	--uu uuuu
OPTION	—	1111 1111	1111 1111
TRISB	—	--11 1111	--11 1111
TRISC	—	--11 1111	--11 1111

Legend: u = unchanged, x = unknown, - = unimplemented bit, read as '0', q = value depends on condition.

**Note 1:** Bits <7:2> of W register contain oscillator calibration values due to MOVLW XX instruction at top of memory.

**Note 2:** See Table 7-7 for reset value for specific conditions.

**Note 3:** If reset was due to wake-up on pin change, then bit 7 = 1. All other resets will cause bit 7 = 0.

**TABLE 7-4: RESET CONDITION FOR SPECIAL REGISTERS**

	STATUS Addr: 03h	PCL Addr: 02h
Power on reset	0001 1xxx	1111 1111
MCLR reset during normal operation	000u uuuu	1111 1111
MCLR reset during SLEEP	0001 0uuu	1111 1111
WDT reset during SLEEP	0000 0uuu	1111 1111
WDT reset normal operation	0000 uuuu	1111 1111
Wake-up from SLEEP on pin change	1001 0uuu	1111 1111

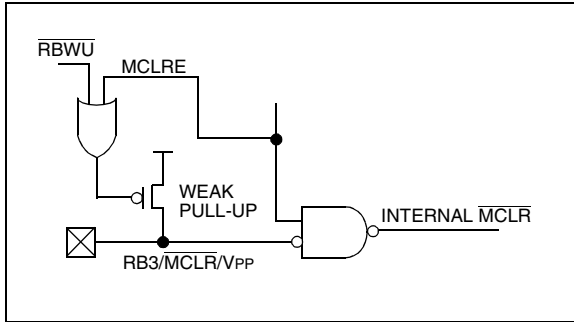
Legend: u = unchanged, x = unknown, - = unimplemented bit, read as '0'.

# PIC16C505

## 7.3.1 $\overline{\text{MCLR}}$ ENABLE

This configuration bit when unprogrammed (left in the '1' state) enables the external  $\overline{\text{MCLR}}$  function. When programmed, the  $\overline{\text{MCLR}}$  function is tied to the internal VDD, and the pin is assigned to be a I/O. See Figure 7-6.

**FIGURE 7-6:  $\overline{\text{MCLR}}$  SELECT**



## 7.4 Power-On Reset (POR)

The PIC16C505 family incorporates on-chip Power-On Reset (POR) circuitry, which provides an internal chip reset for most power-up situations.

The on-chip POR circuit holds the chip in reset until VDD has reached a high enough level for proper operation. To take advantage of the internal POR, program the RB3/MCLR/VPP pin as  $\overline{\text{MCLR}}$  and tie through a resistor to VDD or program the pin as RB3. An internal weak pull-up resistor is implemented using a transistor. Refer to Table 10-1 for the pull-up resistor ranges. This will eliminate external RC components usually needed to create a Power-on Reset. A maximum rise time for VDD is specified. See Electrical Specifications for details.

When the device starts normal operation (exits the reset condition), device operating parameters (voltage, frequency, temperature, ...) must be met to ensure operation. If these conditions are not met, the device must be held in reset until the operating parameters are met.

A simplified block diagram of the on-chip Power-On Reset circuit is shown in Figure 7-7.

The Power-On Reset circuit and the Device Reset Timer (Section 7.5) circuit are closely related. On power-up, the reset latch is set and the DRT is reset. The DRT timer begins counting once it detects  $\overline{\text{MCLR}}$  to be high. After the time-out period, which is typically 18 ms, it will reset the reset latch and thus end the on-chip reset signal.

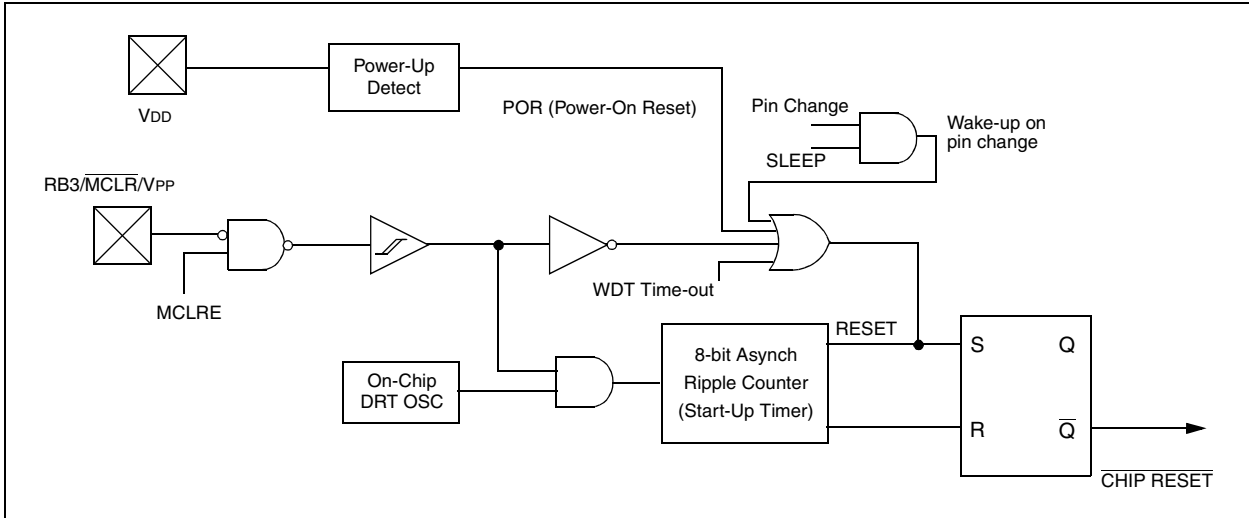
A power-up example where  $\overline{\text{MCLR}}$  is held low is shown in Figure 7-8. VDD is allowed to rise and stabilize before bringing  $\overline{\text{MCLR}}$  high. The chip will actually come out of reset TDRT msec after  $\overline{\text{MCLR}}$  goes high.

In Figure 7-9, the on-chip Power-On Reset feature is being used ( $\overline{\text{MCLR}}$  and VDD are tied together or the pin is programmed to be RB3.). The VDD is stable before the start-up timer times out and there is no problem in getting a proper reset. However, Figure 7-10 depicts a problem situation where VDD rises too slowly. The time between when the DRT senses that  $\overline{\text{MCLR}}$  is high and when  $\overline{\text{MCLR}}$  and VDD actually reach their full value, is too long. In this situation, when the start-up timer times out, VDD has not reached the VDD (min) value and the chip may not function correctly. For such situations, we recommend that external RC circuits be used to achieve longer POR delay times (Figure 7-9).

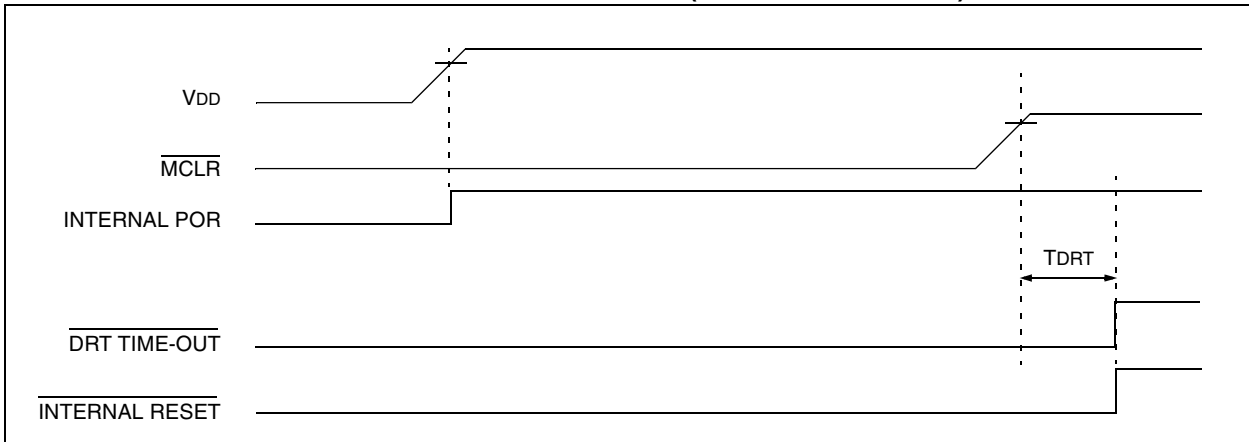
**Note:** When the device starts normal operation (exits the reset condition), device operating parameters (voltage, frequency, temperature, etc.) must be met to ensure operation. If these conditions are not met, the device must be held in reset until the operating conditions are met.

For additional information refer to Application Notes "Power-Up Considerations" - AN522 and "Power-up Trouble Shooting" - AN607.

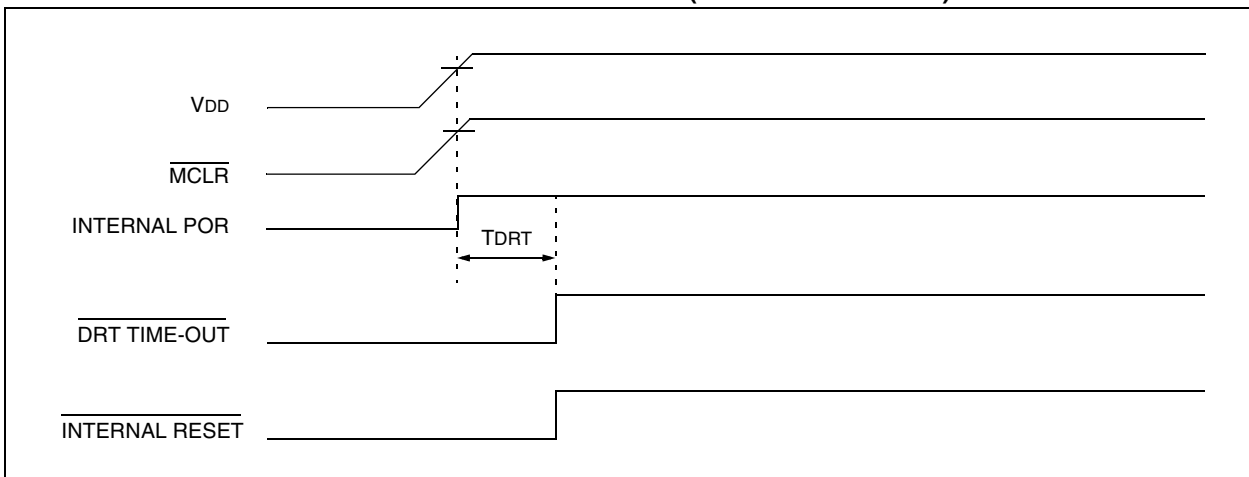
**FIGURE 7-7: SIMPLIFIED BLOCK DIAGRAM OF ON-CHIP RESET CIRCUIT**



**FIGURE 7-8: TIME-OUT SEQUENCE ON POWER-UP ( $\overline{\text{MCLR}}$  PULLED LOW)**

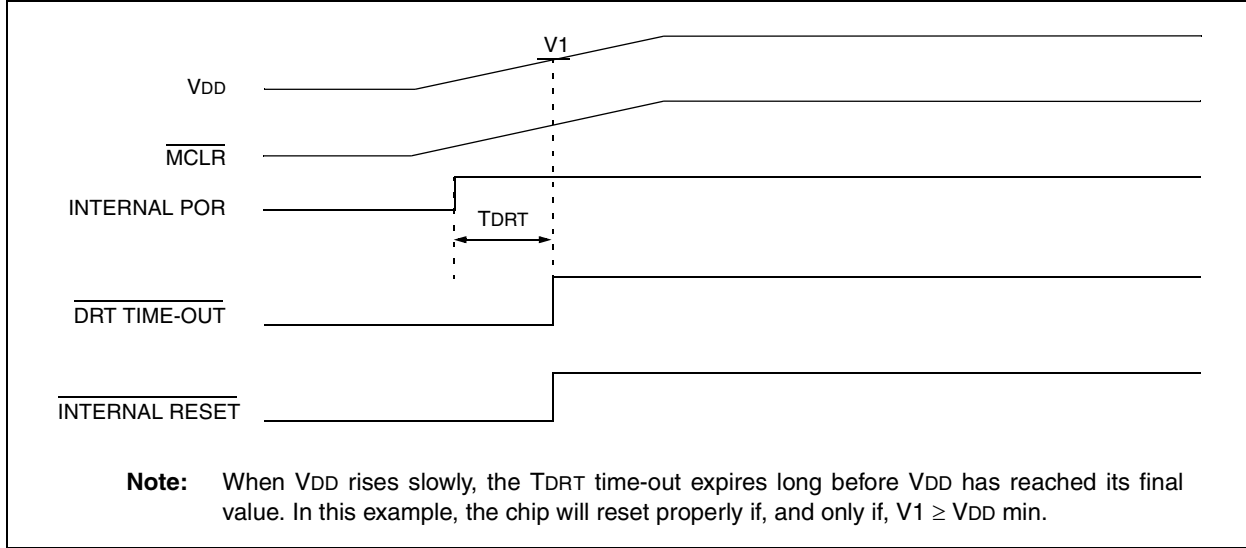


**FIGURE 7-9: TIME-OUT SEQUENCE ON POWER-UP ( $\overline{\text{MCLR}}$  TIED TO  $V_{DD}$ ): FAST  $V_{DD}$  RISE TIME**



# PIC16C505

**FIGURE 7-10: TIME-OUT SEQUENCE ON POWER-UP ( $\overline{\text{MCLR}}$  TIED TO  $V_{\text{DD}}$ ): SLOW  $V_{\text{DD}}$  RISE TIME**



## 7.5 Device Reset Timer (DRT)

In the PIC16C505, the DRT runs any time the device is powered up. DRT runs from RESET and varies based on oscillator selection and reset type (see Table 7-5).

The DRT operates on an internal RC oscillator. The processor is kept in RESET as long as the DRT is active. The DRT delay allows  $V_{\text{DD}}$  to rise above  $V_{\text{DD min}}$  and for the oscillator to stabilize.

Oscillator circuits based on crystals or ceramic resonators require a certain time after power-up to establish a stable oscillation. The on-chip DRT keeps the device in a RESET condition for approximately 18 ms after  $\overline{\text{MCLR}}$  has reached a logic high ( $V_{\text{IH}}\overline{\text{MCLR}}$ ) level. Thus, programming RB3/ $\overline{\text{MCLR}}$ / $V_{\text{PP}}$  as  $\overline{\text{MCLR}}$  and using an external RC network connected to the  $\overline{\text{MCLR}}$  input is not required in most cases, allowing for savings in cost-sensitive and/or space restricted applications, as well as allowing the use of the RB3/ $\overline{\text{MCLR}}$ / $V_{\text{PP}}$  pin as a general purpose input.

The Device Reset time delay will vary from chip to chip due to  $V_{\text{DD}}$ , temperature and process variation. See AC parameters for details.

The DRT will also be triggered upon a Watchdog Timer time-out. This is particularly important for applications using the WDT to wake from SLEEP mode automatically.

Reset sources are POR,  $\overline{\text{MCLR}}$ , WDT time-out and Wake-up on pin change. (See Section 7.9.2, Notes 1, 2, and 3, page 37.)

## 7.6 Watchdog Timer (WDT)

The Watchdog Timer (WDT) is a free running on-chip RC oscillator, which does not require any external components. This RC oscillator is separate from the external RC oscillator of the RB5/OSC1/CLKIN pin and the internal 4 MHz oscillator. That means that the WDT will run even if the main processor clock has been stopped, for example, by execution of a SLEEP instruction. During normal operation or SLEEP, a WDT reset or wake-up reset generates a device RESET.

The  $\overline{\text{TO}}$  bit (STATUS<4>) will be cleared upon a Watchdog Timer reset.

The WDT can be permanently disabled by programming the configuration bit WDTE as a '0' (Section 7.1). Refer to the PIC16C505 Programming Specifications to determine how to access the configuration word.

**TABLE 7-5: DRT (DEVICE RESET TIMER PERIOD)**

Oscillator Configuration	POR Reset	Subsequent Resets
IntRC & ExtRC	18 ms (typical)	300 $\mu\text{s}$ (typical)
HS, XT & LP	18 ms (typical)	18 ms (typical)

## 7.6.1 WDT PERIOD

The WDT has a nominal time-out period of 18 ms, (with no prescaler). If a longer time-out period is desired, a prescaler with a division ratio of up to 1:128 can be assigned to the WDT (under software control) by writing to the OPTION register. Thus, a time-out period of a nominal 2.3 seconds can be realized. These periods vary with temperature, VDD and part-to-part process variations (see DC specs).

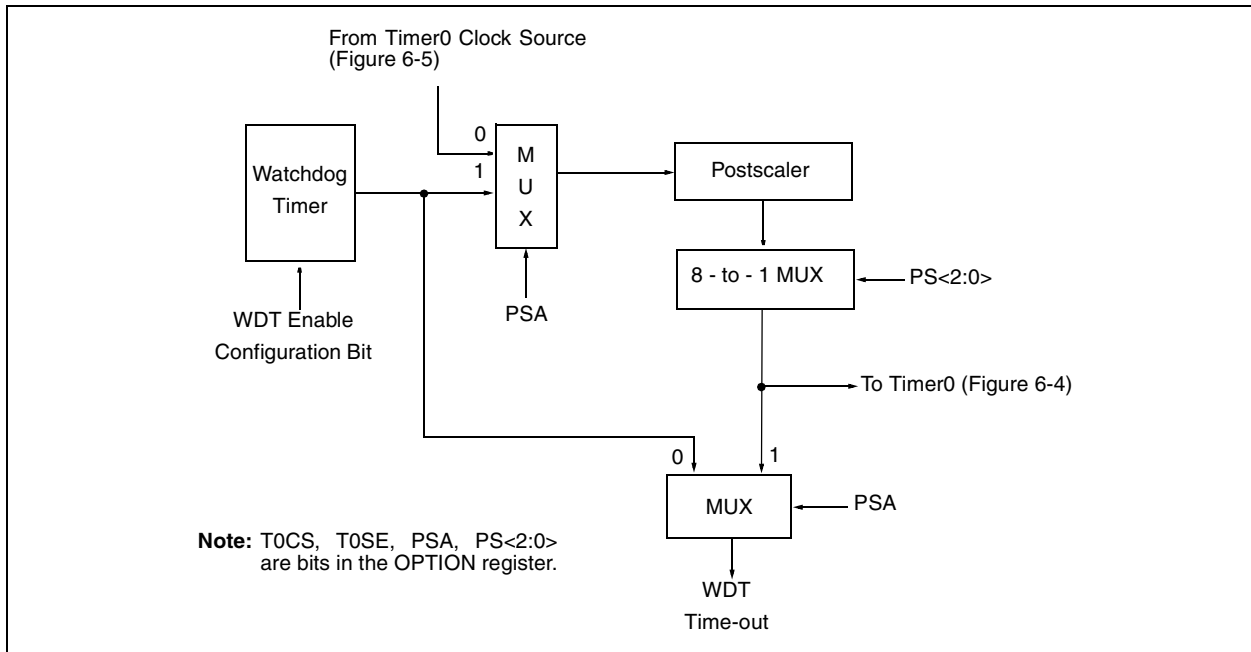
Under worst case conditions (VDD = Min., Temperature = Max., max. WDT prescaler), it may take several seconds before a WDT time-out occurs.

## 7.6.2 WDT PROGRAMMING CONSIDERATIONS

The CLRWDT instruction clears the WDT and the postscaler, if assigned to the WDT, and prevents it from timing out and generating a device RESET.

The SLEEP instruction resets the WDT and the postscaler, if assigned to the WDT. This gives the maximum SLEEP time before a WDT wake-up reset.

**FIGURE 7-11: WATCHDOG TIMER BLOCK DIAGRAM**



**TABLE 7-6: SUMMARY OF REGISTERS ASSOCIATED WITH THE WATCHDOG TIMER**

Address	Name	Bit 7	Bit 6	Bit 5	Bit 4	Bit 3	Bit 2	Bit 1	Bit 0	Value on Power-On Reset	Value on All Other Resets
N/A	OPTION	RBWU	RBPU	T0CS	T0SE	PSA	PS2	PS1	PS0	1111 1111	1111 1111

Legend: Shaded boxes = Not used by Watchdog Timer, — = unimplemented, read as '0', u = unchanged.

# PIC16C505

## 7.7 Time-Out Sequence, Power Down, and Wake-up from SLEEP Status Bits ( $\overline{TO}/\overline{PD}/\overline{RBWUF}$ )

The  $\overline{TO}$ ,  $\overline{PD}$ , and  $\overline{RBWUF}$  bits in the STATUS register can be tested to determine if a RESET condition has been caused by a power-up condition, a  $\overline{MCLR}$  or Watchdog Timer (WDT) reset.

**TABLE 7-7:  $\overline{TO}/\overline{PD}/\overline{RBWUF}$  STATUS AFTER RESET**

$\overline{RBWUF}$	$\overline{TO}$	$\overline{PD}$	RESET caused by
0	0	0	WDT wake-up from SLEEP
0	0	u	WDT time-out (not from SLEEP)
0	1	0	$\overline{MCLR}$ wake-up from SLEEP
0	1	1	Power-up
0	u	u	$\overline{MCLR}$ not during SLEEP
1	1	0	Wake-up from SLEEP on pin change

Legend: u = unchanged

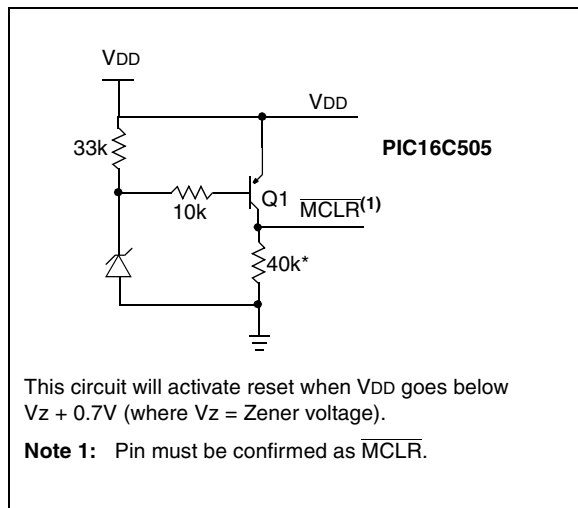
**Note 1:** The  $\overline{TO}$ ,  $\overline{PD}$ , and  $\overline{RBWUF}$  bits maintain their status (u) until a reset occurs. A low-pulse on the  $\overline{MCLR}$  input does not change the  $\overline{TO}$ ,  $\overline{PD}$ , and  $\overline{RBWUF}$  status bits.

## 7.8 Reset on Brown-Out

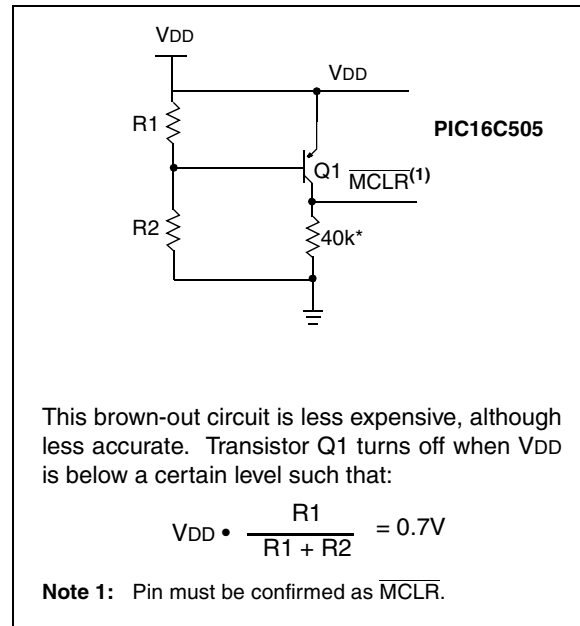
A brown-out is a condition where device power ( $V_{DD}$ ) dips below its minimum value, but not to zero, and then recovers. The device should be reset in the event of a brown-out.

To reset PIC16C505 devices when a brown-out occurs, external brown-out protection circuits may be built, as shown in Figure 7-12 and Figure 7-13.

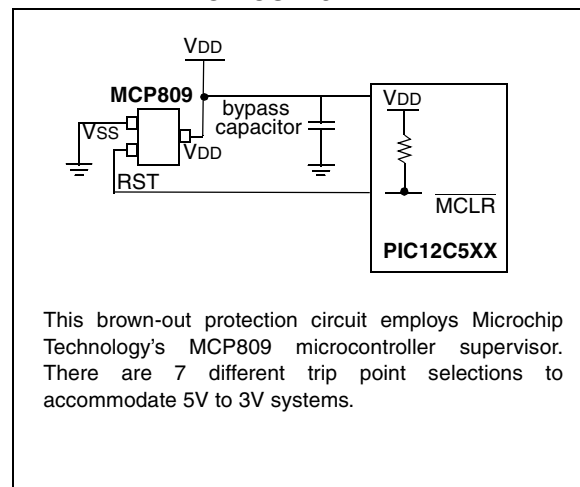
**FIGURE 7-12: BROWN-OUT PROTECTION CIRCUIT 1**



**FIGURE 7-13: BROWN-OUT PROTECTION CIRCUIT 2**



**FIGURE 7-14: BROWN-OUT PROTECTION CIRCUIT 3**



## 7.9 Power-Down Mode (SLEEP)

A device may be powered down (SLEEP) and later powered up (Wake-up from SLEEP).

### 7.9.1 SLEEP

The Power-Down mode is entered by executing a SLEEP instruction.

If enabled, the Watchdog Timer will be cleared but keeps running, the  $\overline{TO}$  bit (STATUS<4>) is set, the  $\overline{PD}$  bit (STATUS<3>) is cleared and the oscillator driver is turned off. The I/O ports maintain the status they had before the SLEEP instruction was executed (driving high, driving low or hi-impedance).

It should be noted that a RESET generated by a WDT time-out does not drive the  $\overline{MCLR}$  pin low.

For lowest current consumption while powered down, the TOCKI input should be at VDD or VSS and the RB3/ $\overline{MCLR}$ /VPP pin must be at a logic high level ( $V_{IHMC}$ ) if  $\overline{MCLR}$  is enabled.

### 7.9.2 WAKE-UP FROM SLEEP

The device can wake-up from SLEEP through one of the following events:

1. An external reset input on RB3/ $\overline{MCLR}$ /VPP pin, when configured as  $\overline{MCLR}$ .
2. A Watchdog Timer time-out reset (if WDT was enabled).
3. A change on input pin RB0, RB1, RB3 or RB4 when wake-up on change is enabled.

These events cause a device reset. The  $\overline{TO}$ ,  $\overline{PD}$ , and RBWUF bits can be used to determine the cause of device reset. The  $\overline{TO}$  bit is cleared if a WDT time-out occurred (and caused wake-up). The  $\overline{PD}$  bit, which is set on power-up, is cleared when SLEEP is invoked. The RBWUF bit indicates a change in state while in SLEEP at pins RB0, RB1, RB3 or RB4 (since the last file or bit operation on RB port).

**Caution:** Right before entering SLEEP, read the input pins. When in SLEEP, wake up occurs when the values at the pins change from the state they were in at the last reading. If a wake-up on change occurs and the pins are not read before reentering SLEEP, a wake-up will occur immediately even if no pins change while in SLEEP mode.

The WDT is cleared when the device wakes from sleep, regardless of the wake-up source.

## 7.10 Program Verification/Code Protection

If the code protection bit has not been programmed, the on-chip program memory can be read out for verification purposes.

The first 64 locations and the last location (OSCCAL) can be read, regardless of the code protection bit setting.

### 7.11 ID Locations

Four memory locations are designated as ID locations where the user can store checksum or other code-identification numbers. These locations are not accessible during normal execution, but are readable and writable during program/verify.

Use only the lower 4 bits of the ID locations and always program the upper 8 bits as '0's.

# PIC16C505

## 7.12 In-Circuit Serial Programming

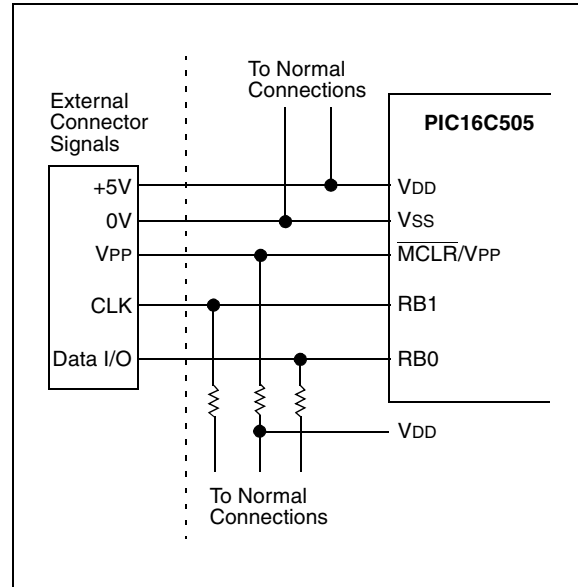
The PIC16C505 microcontrollers can be serially programmed while in the end application circuit. This is simply done with two lines for clock and data, and three other lines for power, ground, and the programming voltage. This allows customers to manufacture boards with unprogrammed devices, and then program the microcontroller just before shipping the product. This also allows the most recent firmware or a custom firmware to be programmed.

The device is placed into a program/verify mode by holding the RB1 and RB0 pins low while raising the MCLR (VPP) pin from  $V_{IL}$  to  $V_{IH}$  (see programming specification). RB1 becomes the programming clock and RB0 becomes the programming data. Both RB1 and RB0 are Schmitt Trigger inputs in this mode.

After reset, a 6-bit command is then supplied to the device. Depending on the command, 14 bits of program data are then supplied to or from the device, depending if the command was a load or a read. For complete details of serial programming, please refer to the PIC16C505 Programming Specifications.

A typical in-circuit serial programming connection is shown in Figure 7-15.

**FIGURE 7-15: TYPICAL IN-CIRCUIT SERIAL PROGRAMMING CONNECTION**



## 8.0 INSTRUCTION SET SUMMARY

Each PIC16C505 instruction is a 12-bit word divided into an OPCODE, which specifies the instruction type, and one or more operands which further specify the operation of the instruction. The PIC16C505 instruction set summary in Table 8-2 groups the instructions into byte-oriented, bit-oriented, and literal and control operations. Table 8-1 shows the opcode field descriptions.

For **byte-oriented** instructions, 'f' represents a file register designator and 'd' represents a destination designator. The file register designator is used to specify which one of the 32 file registers is to be used by the instruction.

The destination designator specifies where the result of the operation is to be placed. If 'd' is '0', the result is placed in the W register. If 'd' is '1', the result is placed in the file register specified in the instruction.

For **bit-oriented** instructions, 'b' represents a bit field designator which selects the number of the bit affected by the operation, while 'f' represents the number of the file in which the bit is located.

For **literal and control** operations, 'k' represents an 8 or 9-bit constant or literal value.

**TABLE 8-1: OPCODE FIELD DESCRIPTIONS**

Field	Description
f	Register file address (0x00 to 0x7F)
w	Working register (accumulator)
b	Bit address within an 8-bit file register
k	Literal field, constant data or label
x	Don't care location (= 0 or 1) The assembler will generate code with x = 0. It is the recommended form of use for compatibility with all Microchip software tools.
d	Destination select; d = 0 (store result in W) d = 1 (store result in file register 'f') Default is d = 1
label	Label name
TOS	Top of Stack
PC	Program Counter
WDT	Watchdog Timer Counter
$\overline{TO}$	Time-Out bit
$\overline{PD}$	Power-Down bit
dest	Destination, either the W register or the specified register file location
[ ]	Options
( )	Contents
→	Assigned to
< >	Register bit field
∈	In the set of
<i>italics</i>	User defined term (font is courier)

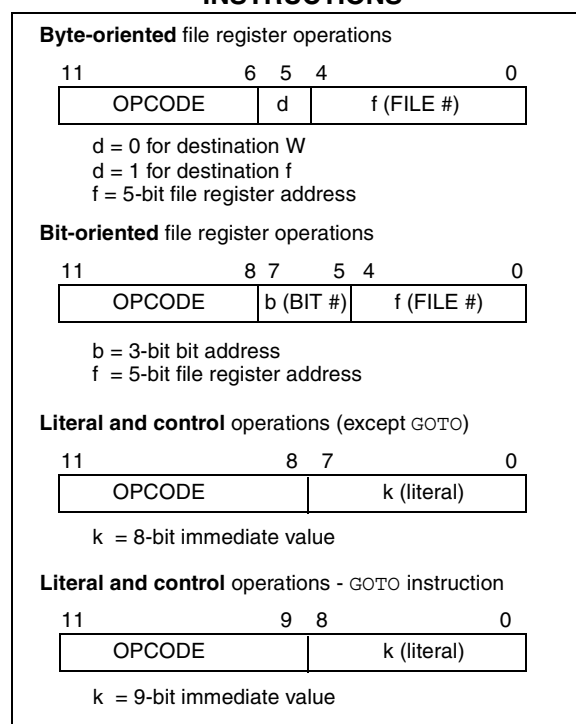
All instructions are executed within a single instruction cycle, unless a conditional test is true or the program counter is changed as a result of an instruction. In this case, the execution takes two instruction cycles. One instruction cycle consists of four oscillator periods. Thus, for an oscillator frequency of 4 MHz, the normal instruction execution time is 1  $\mu$ s. If a conditional test is true or the program counter is changed as a result of an instruction, the instruction execution time is 2  $\mu$ s.

Figure 8-1 shows the three general formats that the instructions can have. All examples in the figure use the following format to represent a hexadecimal number:

0xhhh

where 'h' signifies a hexadecimal digit.

**FIGURE 8-1: GENERAL FORMAT FOR INSTRUCTIONS**



# PIC16C505

TABLE 8-2: INSTRUCTION SET SUMMARY

Mnemonic, Operands	Description	Cycles	12-Bit Opcode			Status Affected	Notes
			MSb	LSb			
<b>ADDWF</b> f,d	Add W and f	1	0001	11df	ffff	C,DC,Z	1,2,4
<b>ANDWF</b> f,d	AND W with f	1	0001	01df	ffff	Z	2,4
<b>CLRF</b> f	Clear f	1	0000	011f	ffff	Z	4
<b>CLRW</b> –	Clear W	1	0000	0100	0000	Z	
<b>COMF</b> f,d	Complement f	1	0010	01df	ffff	Z	
<b>DECF</b> f,d	Decrement f	1	0000	11df	ffff	Z	2,4
<b>DECFSZ</b> f,d	Decrement f, Skip if 0	1(2)	0010	11df	ffff	None	2,4
<b>INCF</b> f,d	Increment f	1	0010	10df	ffff	Z	2,4
<b>INCFSZ</b> f,d	Increment f, Skip if 0	1(2)	0011	11df	ffff	None	2,4
<b>IORWF</b> f,d	Inclusive OR W with f	1	0001	00df	ffff	Z	2,4
<b>MOVF</b> f,d	Move f	1	0010	00df	ffff	Z	2,4
<b>MOVWF</b> f	Move W to f	1	0000	001f	ffff	None	1,4
<b>NOP</b> –	No Operation	1	0000	0000	0000	None	
<b>RLF</b> f,d	Rotate left f through Carry	1	0011	01df	ffff	C	2,4
<b>RRF</b> f,d	Rotate right f through Carry	1	0011	00df	ffff	C	2,4
<b>SUBWF</b> f,d	Subtract W from f	1	0000	10df	ffff	C,DC,Z	1,2,4
<b>SWAPF</b> f,d	Swap f	1	0011	10df	ffff	None	2,4
<b>XORWF</b> f,d	Exclusive OR W with f	1	0001	10df	ffff	Z	2,4
<b>BIT-ORIENTED FILE REGISTER OPERATIONS</b>							
<b>BCF</b> f,b	Bit Clear f	1	0100	bbbf	ffff	None	2,4
<b>BSF</b> f,b	Bit Set f	1	0101	bbbf	ffff	None	2,4
<b>BTFSC</b> f,b	Bit Test f, Skip if Clear	1 (2)	0110	bbbf	ffff	None	
<b>BTFSS</b> f,b	Bit Test f, Skip if Set	1 (2)	0111	bbbf	ffff	None	
<b>LITERAL AND CONTROL OPERATIONS</b>							
<b>ANDLW</b> k	AND literal with W	1	1110	kkkk	kkkk	Z	
<b>CALL</b> k	Call subroutine	2	1001	kkkk	kkkk	None	1
<b>CLRWDT</b> k	Clear Watchdog Timer	1	0000	0000	0100	$\overline{TO}$ , $\overline{PD}$	
<b>GOTO</b> k	Unconditional branch	2	101k	kkkk	kkkk	None	
<b>IORLW</b> k	Inclusive OR Literal with W	1	1101	kkkk	kkkk	Z	
<b>MOVLW</b> k	Move Literal to W	1	1100	kkkk	kkkk	None	
<b>OPTION</b> –	Load OPTION register	1	0000	0000	0010	None	
<b>RETLW</b> k	Return, place Literal in W	2	1000	kkkk	kkkk	None	
<b>SLEEP</b> –	Go into standby mode	1	0000	0000	0011	$\overline{TO}$ , $\overline{PD}$	
<b>TRIS</b> f	Load TRIS register	1	0000	0000	0fff	None	3
<b>XORLW</b> k	Exclusive OR Literal to W	1	1111	kkkk	kkkk	Z	

**Note 1:** The 9th bit of the program counter will be forced to a '0' by any instruction that writes to the PC except for GOTO. (Section 4.6)

- When an I/O register is modified as a function of itself (e.g. MOVF PORTB, 1), the value used will be that value present on the pins themselves. For example, if the data latch is '1' for a pin configured as input and is driven low by an external device, the data will be written back with a '0'.
- The instruction TRIS f, where f = 6 causes the contents of the W register to be written to the tristate latches of PORTB. A '1' forces the pin to a hi-impedance state and disables the output buffers.
- If this instruction is executed on the TMR0 register (and, where applicable, d = 1), the prescaler will be cleared (if assigned to TMR0).

## **ADDWF**      **Add W and f**

Syntax:      [ *label* ] ADDWF   f,d

Operands:     $0 \leq f \leq 31$   
 $d \in [0,1]$

Operation:    (W) + (f) → (dest)

Status Affected: C, DC, Z

Encoding:    

0001	11df	ffff
------	------	------

Description:    Add the contents of the W register and register 'f'. If 'd' is 0, the result is stored in the W register. If 'd' is '1', the result is stored back in register 'f'.

Words:        1

Cycles:        1

Example:      ADDWF   FSR, 0

Before Instruction

W = 0x17  
 FSR = 0xC2

After Instruction

W = 0xD9  
 FSR = 0xC2

## **ANDWF**      **AND W with f**

Syntax:      [ *label* ] ANDWF   f,d

Operands:     $0 \leq f \leq 31$   
 $d \in [0,1]$

Operation:    (W) .AND. (f) → (dest)

Status Affected: Z

Encoding:    

0001	01df	ffff
------	------	------

Description:    The contents of the W register are AND'ed with register 'f'. If 'd' is 0, the result is stored in the W register. If 'd' is '1', the result is stored back in register 'f'.

Words:        1

Cycles:        1

Example:      ANDWF   FSR,    1

Before Instruction

W = 0x17  
 FSR = 0xC2

After Instruction

W = 0x17  
 FSR = 0x02

## **ANDLW**      **And literal with W**

Syntax:      [ *label* ] ANDLW   k

Operands:     $0 \leq k \leq 255$

Operation:    (W).AND. (k) → (W)

Status Affected: Z

Encoding:    

1110	kkkk	kkkk
------	------	------

Description:    The contents of the W register are AND'ed with the eight-bit literal 'k'. The result is placed in the W register.

Words:        1

Cycles:        1

Example:      ANDLW   0x5F

Before Instruction

W = 0xA3

After Instruction

W = 0x03

## **BCF**          **Bit Clear f**

Syntax:      [ *label* ] BCF    f,b

Operands:     $0 \leq f \leq 31$   
 $0 \leq b \leq 7$

Operation:     $0 \rightarrow (f<b>)$

Status Affected: None

Encoding:    

0100	bbbf	ffff
------	------	------

Description:    Bit 'b' in register 'f' is cleared.

Words:        1

Cycles:        1

Example:      BCF      FLAG\_REG,    7

Before Instruction

FLAG\_REG = 0xC7

After Instruction

FLAG\_REG = 0x47

# PIC16C505

## BSF Bit Set f

Syntax: [ *label* ] BSF f,b  
 Operands:  $0 \leq f \leq 31$   
 $0 \leq b \leq 7$   
 Operation:  $1 \rightarrow (f<b>)$   
 Status Affected: None  
 Encoding: 

0101	bbbbf	ffff
------	-------	------

  
 Description: Bit 'b' in register 'f' is set.  
 Words: 1  
 Cycles: 1  
 Example: BSF FLAG\_REG, 7

Before Instruction  
 FLAG\_REG = 0x0A  
 After Instruction  
 FLAG\_REG = 0x8A

## BTFSS Bit Test f, Skip if Set

Syntax: [ *label* ] BTFSS f,b  
 Operands:  $0 \leq f \leq 31$   
 $0 \leq b \leq 7$   
 Operation: skip if  $(f<b>) = 0$   
 Status Affected: None  
 Encoding: 

0110	bbbbf	ffff
------	-------	------

  
 Description: If bit 'b' in register 'f' is 0, then the next instruction is skipped.  
 If bit 'b' is 0, then the next instruction fetched during the current instruction execution is discarded, and a NOP is executed instead, making this a 2 cycle instruction.  
 Words: 1  
 Cycles: 1(2)  
 Example: HERE BTFSS FLAG, 1  
 FALSE GOTO PROCESS\_CODE  
 TRUE •  
 •  
 •

Before Instruction  
 PC = address (HERE)  
 After Instruction  
 if FLAG<1> = 0,  
 PC = address (TRUE);  
 if FLAG<1> = 1,  
 PC = address (FALSE)

## BTFSS Bit Test f, Skip if Set

Syntax: [ *label* ] BTFSS f,b  
 Operands:  $0 \leq f \leq 31$   
 $0 \leq b < 7$   
 Operation: skip if  $(f<b>) = 1$   
 Status Affected: None  
 Encoding: 

0111	bbbbf	ffff
------	-------	------

  
 Description: If bit 'b' in register 'f' is '1', then the next instruction is skipped.  
 If bit 'b' is '1', then the next instruction fetched during the current instruction execution, is discarded and a NOP is executed instead, making this a 2 cycle instruction.  
 Words: 1  
 Cycles: 1(2)  
 Example: HERE BTFSS FLAG, 1  
 FALSE GOTO PROCESS\_CODE  
 TRUE •  
 •  
 •

Before Instruction  
 PC = address (HERE)  
 After Instruction  
 if FLAG<1> = 0,  
 PC = address (FALSE);  
 if FLAG<1> = 1,  
 PC = address (TRUE)

## CALL Subroutine Call

**Syntax:** [ *label* ] CALL *k*

**Operands:**  $0 \leq k \leq 255$

**Operation:** (PC) + 1 → Top of Stack;  
 $k \rightarrow PC<7:0>$ ;  
 (STATUS<6:5>) → PC<10:9>;  
 $0 \rightarrow PC<8>$

**Status Affected:** None

**Encoding:**

1001	kkkk	kkkk
------	------	------

**Description:** Subroutine call. First, return address (PC+1) is pushed onto the stack. The eight bit immediate address is loaded into PC bits <7:0>. The upper bits PC<10:9> are loaded from STATUS<6:5>, PC<8> is cleared. CALL is a two cycle instruction.

**Words:** 1

**Cycles:** 2

**Example:**     HERE     CALL     THERE

Before Instruction  
 PC = address (HERE)

After Instruction  
 PC = address (THERE)  
 TOS = address (HERE + 1)

## CLRF Clear f

**Syntax:** [ *label* ] CLRF *f*

**Operands:**  $0 \leq f \leq 31$

**Operation:**  $00h \rightarrow (f)$ ;  
 $1 \rightarrow Z$

**Status Affected:** Z

**Encoding:**

0000	011f	ffff
------	------	------

**Description:** The contents of register 'f' are cleared and the Z bit is set.

**Words:** 1

**Cycles:** 1

**Example:**     CLRF     FLAG\_REG

Before Instruction  
 FLAG\_REG = 0x5A

After Instruction  
 FLAG\_REG = 0x00  
 Z = 1

## CLRW Clear W

**Syntax:** [ *label* ] CLRW

**Operands:** None

**Operation:**  $00h \rightarrow (W)$ ;  
 $1 \rightarrow Z$

**Status Affected:** Z

**Encoding:**

0000	0100	0000
------	------	------

**Description:** The W register is cleared. Zero bit (Z) is set.

**Words:** 1

**Cycles:** 1

**Example:**     CLRW

Before Instruction  
 W = 0x5A

After Instruction  
 W = 0x00  
 Z = 1

## CLRWDTClear Watchdog Timer

**Syntax:** [ *label* ] CLRWDTClear Watchdog Timer

**Operands:** None

**Operation:**  $00h \rightarrow WDT$ ;  
 $0 \rightarrow WDT$  prescaler (if assigned);  
 $1 \rightarrow \overline{TO}$ ;  
 $1 \rightarrow \overline{PD}$

**Status Affected:**  $\overline{TO}$ ,  $\overline{PD}$

**Encoding:**

0000	0000	0100
------	------	------

**Description:** The CLRWDTClear Watchdog Timer instruction resets the WDT. It also resets the prescaler, if the prescaler is assigned to the WDT and not Timer0. Status bits  $\overline{TO}$  and  $\overline{PD}$  are set.

**Words:** 1

**Cycles:** 1

**Example:**     CLRWDTClear Watchdog Timer

Before Instruction  
 WDT counter = ?

After Instruction  
 WDT counter = 0x00  
 WDT prescale = 0  
 $\overline{TO} = 1$   
 $\overline{PD} = 1$

# PIC16C505

## COMF Complement f

Syntax: [ *label* ] COMF f,d  
 Operands:  $0 \leq f \leq 31$   
 $d \in [0,1]$   
 Operation:  $(\bar{f}) \rightarrow (\text{dest})$   
 Status Affected: Z  
 Encoding: 

0010	01df	ffff
------	------	------

  
 Description: The contents of register 'f' are complemented. If 'd' is 0, the result is stored in the W register. If 'd' is 1, the result is stored back in register 'f'.  
 Words: 1  
 Cycles: 1  
 Example: COMF REG1, 0

Before Instruction  
 REG1 = 0x13  
 After Instruction  
 REG1 = 0x13  
 W = 0xEC

## DECf Decrement f

Syntax: [ *label* ] DECf f,d  
 Operands:  $0 \leq f \leq 31$   
 $d \in [0,1]$   
 Operation:  $(f) - 1 \rightarrow (\text{dest})$   
 Status Affected: Z  
 Encoding: 

0000	11df	ffff
------	------	------

  
 Description: Decrement register 'f'. If 'd' is 0, the result is stored in the W register. If 'd' is 1, the result is stored back in register 'f'.  
 Words: 1  
 Cycles: 1  
 Example: DECf CNT, 1

Before Instruction  
 CNT = 0x01  
 Z = 0  
 After Instruction  
 CNT = 0x00  
 Z = 1

## DECFSZ Decrement f, Skip if 0

Syntax: [ *label* ] DECFSZ f,d  
 Operands:  $0 \leq f \leq 31$   
 $d \in [0,1]$   
 Operation:  $(f) - 1 \rightarrow d$ ; skip if result = 0  
 Status Affected: None  
 Encoding: 

0010	11df	ffff
------	------	------

  
 Description: The contents of register 'f' are decremented. If 'd' is 0, the result is placed in the W register. If 'd' is 1, the result is placed back in register 'f'.  
 If the result is 0, the next instruction, which is already fetched, is discarded and a NOP is executed instead making it a two cycle instruction.  
 Words: 1  
 Cycles: 1(2)  
 Example: HERE DECFSZ CNT, 1  
 GOTO LOOP  
 CONTINUE •  
 •  
 •

Before Instruction  
 PC = address (HERE)  
 After Instruction  
 CNT = CNT - 1;  
 if CNT = 0,  
 PC = address (CONTINUE);  
 if CNT  $\neq$  0,  
 PC = address (HERE+1)

## GOTO Unconditional Branch

Syntax: [ *label* ] GOTO k  
 Operands:  $0 \leq k \leq 511$   
 Operation:  $k \rightarrow PC\langle 8:0 \rangle$ ;  
 $STATUS\langle 6:5 \rangle \rightarrow PC\langle 10:9 \rangle$   
 Status Affected: None  
 Encoding: 

101k	kkkk	kkkk
------	------	------

  
 Description: GOTO is an unconditional branch. The 9-bit immediate value is loaded into PC bits <8:0>. The upper bits of PC are loaded from STATUS<6:5>. GOTO is a two cycle instruction.  
 Words: 1  
 Cycles: 2  
 Example: GOTO THERE

After Instruction  
 PC = address (THERE)



# PIC16C505

## **IORLW**      **Inclusive OR literal with W**

Syntax:      [ *label* ] IORLW *k*

Operands:     $0 \leq k \leq 255$

Operation:    (W) .OR. (k) → (W)

Status Affected: Z

Encoding:    

1101	kkkk	kkkk
------	------	------

Description:    The contents of the W register are OR'ed with the eight bit literal 'k'. The result is placed in the W register.

Words:      1

Cycles:      1

Example:      IORLW    0x35

Before Instruction

W = 0x9A

After Instruction

W = 0xBF

Z = 0

## **IORWF**      **Inclusive OR W with f**

Syntax:      [ *label* ] IORWF *f,d*

Operands:     $0 \leq f \leq 31$   
 $d \in [0,1]$

Operation:    (W).OR. (f) → (dest)

Status Affected: Z

Encoding:    

0001	00df	ffff
------	------	------

Description:    Inclusive OR the W register with register 'f'. If 'd' is 0, the result is placed in the W register. If 'd' is 1, the result is placed back in register 'f'.

Words:      1

Cycles:      1

Example:      IORWF                  RESULT, 0

Before Instruction

RESULT = 0x13

W = 0x91

After Instruction

RESULT = 0x13

W = 0x93

Z = 0

## **MOVF**      **Move f**

Syntax:      [ *label* ] MOVF *f,d*

Operands:     $0 \leq f \leq 31$   
 $d \in [0,1]$

Operation:    (f) → (dest)

Status Affected: Z

Encoding:    

0010	00df	ffff
------	------	------

Description:    The contents of register 'f' are moved to destination 'd'. If 'd' is 0, destination is the W register. If 'd' is 1, the destination is file register 'f'. 'd' = 1 is useful as a test of a file register since status flag Z is affected.

Words:      1

Cycles:      1

Example:      MOVF    FSR,    0

After Instruction

W = value in FSR register

## **MOVLW**      **Move Literal to W**

Syntax:      [ *label* ] MOVLW *k*

Operands:     $0 \leq k \leq 255$

Operation:     $k \rightarrow (W)$

Status Affected: None

Encoding:    

1100	kkkk	kkkk
------	------	------

Description:    The eight bit literal 'k' is loaded into the W register. The don't cares will assembled as 0s.

Words:      1

Cycles:      1

Example:      MOVLW    0x5A

After Instruction

W = 0x5A

## **MOVWF**      **Move W to f**

Syntax:      [ *label* ] MOVWF f  
 Operands:     $0 \leq f \leq 31$   
 Operation:    (W) → (f)  
 Status Affected: None  
 Encoding:    

0000	001f	ffff
------	------	------

  
 Description:    Move data from the W register to register 'f'.  
 Words:        1  
 Cycles:       1  
 Example:      MOVWF    TEMP\_REG

Before Instruction  
 TEMP\_REG = 0xFF  
 W = 0x4F  
 After Instruction  
 TEMP\_REG = 0x4F  
 W = 0x4F

## **NOP**            **No Operation**

Syntax:      [ *label* ] NOP  
 Operands:    None  
 Operation:    No operation  
 Status Affected: None  
 Encoding:    

0000	0000	0000
------	------	------

  
 Description:    No operation.  
 Words:        1  
 Cycles:       1  
 Example:      NOP

## **OPTION**        **Load OPTION Register**

Syntax:      [ *label* ] OPTION  
 Operands:    None  
 Operation:    (W) → OPTION  
 Status Affected: None  
 Encoding:    

0000	0000	0010
------	------	------

  
 Description:    The content of the W register is loaded into the OPTION register.  
 Words:        1  
 Cycles:       1  
 Example      OPTION

Before Instruction  
 W = 0x07  
 After Instruction  
 OPTION = 0x07

## **RETLW**        **Return with Literal in W**

Syntax:      [ *label* ] RETLW k  
 Operands:     $0 \leq k \leq 255$   
 Operation:     $k \rightarrow (W)$ ;  
                   TOS → PC  
 Status Affected: None  
 Encoding:    

1000	kkkk	kkkk
------	------	------

  
 Description:    The W register is loaded with the eight bit literal 'k'. The program counter is loaded from the top of the stack (the return address). This is a two cycle instruction.  
 Words:        1  
 Cycles:       2  
 Example:      CALL TABLE ;W contains  
    ;table offset  
    ;value.  
    ;W now has table  
    ;value.  
    •  
    •  
    •  
 TABLE      ADDWF PC    ;W = offset  
                  RETLW k1    ;Begin table  
                  RETLW k2    ;  
                  •  
                  •  
                  •  
                  RETLW kn    ; End of table

Before Instruction  
 W = 0x07  
 After Instruction  
 W = value of k8

# PIC16C505

## RLF Rotate Left f through Carry

Syntax: [ *label* ] RLF f,d

Operands:  $0 \leq f \leq 31$   
 $d \in [0,1]$

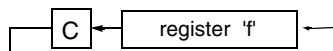
Operation: See description below

Status Affected: C

Encoding: 

0011	01df	ffff
------	------	------

Description: The contents of register 'f' are rotated one bit to the left through the Carry Flag. If 'd' is 0, the result is placed in the W register. If 'd' is 1, the result is stored back in register 'f'.



Words: 1

Cycles: 1

Example: RLF REG1,0

Before Instruction

REG1 = 1110 0110  
C = 0

After Instruction

REG1 = 1110 0110  
W = 1100 1100  
C = 1

## RRF Rotate Right f through Carry

Syntax: [ *label* ] RRF f,d

Operands:  $0 \leq f \leq 31$   
 $d \in [0,1]$

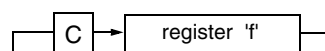
Operation: See description below

Status Affected: C

Encoding: 

0011	00df	ffff
------	------	------

Description: The contents of register 'f' are rotated one bit to the right through the Carry Flag. If 'd' is 0, the result is placed in the W register. If 'd' is 1, the result is placed back in register 'f'.



Words: 1

Cycles: 1

Example: RRF REG1,0

Before Instruction

REG1 = 1110 0110  
C = 0

After Instruction

REG1 = 1110 0110  
W = 0111 0011  
C = 0

**SLEEP**                      **Enter SLEEP Mode**

---

Syntax:                      `[label] SLEEP`

Operands:                    None

Operation:                    `00h` → WDT;  
                                  `0` → WDT prescaler;  
                                  `1` →  $\overline{TO}$ ;  
                                  `0` →  $\overline{PD}$

Status Affected:             $\overline{TO}$ ,  $\overline{PD}$ , RBWUF

Encoding:                    

0000	0000	0011
------	------	------

Description:                    Time-out status bit ( $\overline{TO}$ ) is set. The power down status bit ( $\overline{PD}$ ) is cleared.  
  
                                  RBWUF is unaffected.  
                                  The WDT and its prescaler are cleared.  
                                  The processor is put into SLEEP mode with the oscillator stopped. See section on SLEEP for more details.

Words:                        1

Cycles:                        1

Example:                      `SLEEP`

**SUBWF**                      **Subtract W from f**

---

Syntax:                      `[label] SUBWF f,d`

Operands:                     $0 \leq f \leq 31$   
                                   $d \in [0,1]$

Operation:                     $(f) - (W) \rightarrow (\text{dest})$

Status Affected:            C, DC, Z

Encoding:                    

0000	10df	ffff
------	------	------

Description:                    Subtract (2's complement method) the W register from register 'f'. If 'd' is 0, the result is stored in the W register. If 'd' is 1, the result is stored back in register 'f'.

Words:                        1

Cycles:                        1

Example 1:                    `SUBWF REG1, 1`

Before Instruction

REG1 = 3  
           W = 2  
           C = ?

After Instruction

REG1 = 1  
           W = 2  
           C = 1                    ; result is positive

Example 2:

Before Instruction

REG1 = 2  
           W = 2  
           C = ?

After Instruction

REG1 = 0  
           W = 2  
           C = 1                    ; result is zero

Example 3:

Before Instruction

REG1 = 1  
           W = 2  
           C = ?

After Instruction

REG1 = FF  
           W = 2  
           C = 0                    ; result is negative

# PIC16C505

## SWAPF Swap Nibbles in f

Syntax: `[label] SWAPF f,d`  
Operands:  $0 \leq f \leq 31$   
 $d \in [0,1]$   
Operation:  $(f<3:0>) \rightarrow (dest<7:4>);$   
 $(f<7:4>) \rightarrow (dest<3:0>)$   
Status Affected: None  
Encoding: 

0011	10df	ffff
------	------	------

  
Description: The upper and lower nibbles of register 'f' are exchanged. If 'd' is 0, the result is placed in W register. If 'd' is 1, the result is placed in register 'f'.  
Words: 1  
Cycles: 1  
Example `SWAPF REG1, 0`

Before Instruction  
REG1 = 0xA5  
After Instruction  
REG1 = 0xA5  
W = 0x5A

## TRIS Load TRIS Register

Syntax: `[label] TRIS f`  
Operands:  $f = 6$   
Operation:  $(W) \rightarrow \text{TRIS register } f$   
Status Affected: None  
Encoding: 

0000	0000	0fff
------	------	------

  
Description: TRIS register 'f' ( $f = 6$  or  $7$ ) is loaded with the contents of the W register  
Words: 1  
Cycles: 1  
Example `TRIS PORTB`

Before Instruction  
W = 0xA5  
After Instruction  
TRIS = 0xA5

## XORLW Exclusive OR literal with W

Syntax: `[label] XORLW k`  
Operands:  $0 \leq k \leq 255$   
Operation:  $(W) .XOR. k \rightarrow (W)$   
Status Affected: Z  
Encoding: 

1111	kkkk	kkkk
------	------	------

  
Description: The contents of the W register are XOR'ed with the eight bit literal 'k'. The result is placed in the W register.  
Words: 1  
Cycles: 1  
Example: `XORLW 0xAF`

Before Instruction  
W = 0xB5  
After Instruction  
W = 0x1A

## XORWF Exclusive OR W with f

Syntax: `[label] XORWF f,d`  
Operands:  $0 \leq f \leq 31$   
 $d \in [0,1]$   
Operation:  $(W) .XOR. (f) \rightarrow (dest)$   
Status Affected: Z  
Encoding: 

0001	10df	ffff
------	------	------

  
Description: Exclusive OR the contents of the W register with register 'f'. If 'd' is 0, the result is stored in the W register. If 'd' is 1, the result is stored back in register 'f'.  
Words: 1  
Cycles: 1  
Example `XORWF REG, 1`

Before Instruction  
REG = 0xAF  
W = 0xB5  
After Instruction  
REG = 0x1A  
W = 0xB5

## 9.0 DEVELOPMENT SUPPORT

The PIC<sup>®</sup> microcontrollers and dsPIC<sup>®</sup> digital signal controllers are supported with a full range of software and hardware development tools:

- Integrated Development Environment
  - MPLAB<sup>®</sup> IDE Software
- Compilers/Assemblers/Linkers
  - MPLAB C Compiler for Various Device Families
  - HI-TECH C<sup>®</sup> for Various Device Families
  - MPASM<sup>™</sup> Assembler
  - MPLINK<sup>™</sup> Object Linker/  
MPLIB<sup>™</sup> Object Librarian
  - MPLAB Assembler/Linker/Librarian for Various Device Families
- Simulators
  - MPLAB SIM Software Simulator
- Emulators
  - MPLAB REAL ICE<sup>™</sup> In-Circuit Emulator
- In-Circuit Debuggers
  - MPLAB ICD 3
  - PICKit<sup>™</sup> 3 Debug Express
- Device Programmers
  - PICKit<sup>™</sup> 2 Programmer
  - MPLAB PM3 Device Programmer
- Low-Cost Demonstration/Development Boards, Evaluation Kits, and Starter Kits

## 9.1 MPLAB Integrated Development Environment Software

The MPLAB IDE software brings an ease of software development previously unseen in the 8/16/32-bit microcontroller market. The MPLAB IDE is a Windows<sup>®</sup> operating system-based application that contains:

- A single graphical interface to all debugging tools
  - Simulator
  - Programmer (sold separately)
  - In-Circuit Emulator (sold separately)
  - In-Circuit Debugger (sold separately)
- A full-featured editor with color-coded context
- A multiple project manager
- Customizable data windows with direct edit of contents
- High-level source code debugging
- Mouse over variable inspection
- Drag and drop variables from source to watch windows
- Extensive on-line help
- Integration of select third party tools, such as IAR C Compilers

The MPLAB IDE allows you to:

- Edit your source files (either C or assembly)
- One-touch compile or assemble, and download to emulator and simulator tools (automatically updates all project information)
- Debug using:
  - Source files (C or assembly)
  - Mixed C and assembly
  - Machine code

MPLAB IDE supports multiple debugging tools in a single development paradigm, from the cost-effective simulators, through low-cost in-circuit debuggers, to full-featured emulators. This eliminates the learning curve when upgrading to tools with increased flexibility and power.

## 9.2 MPLAB C Compilers for Various Device Families

The MPLAB C Compiler code development systems are complete ANSI C compilers for Microchip's PIC18, PIC24 and PIC32 families of microcontrollers and the dsPIC30 and dsPIC33 families of digital signal controllers. These compilers provide powerful integration capabilities, superior code optimization and ease of use.

For easy source level debugging, the compilers provide symbol information that is optimized to the MPLAB IDE debugger.

## 9.3 HI-TECH C for Various Device Families

The HI-TECH C Compiler code development systems are complete ANSI C compilers for Microchip's PIC family of microcontrollers and the dsPIC family of digital signal controllers. These compilers provide powerful integration capabilities, omniscient code generation and ease of use.

For easy source level debugging, the compilers provide symbol information that is optimized to the MPLAB IDE debugger.

The compilers include a macro assembler, linker, pre-processor, and one-step driver, and can run on multiple platforms.

## 9.4 MPASM Assembler

The MPASM Assembler is a full-featured, universal macro assembler for PIC10/12/16/18 MCUs.

The MPASM Assembler generates relocatable object files for the MPLINK Object Linker, Intel® standard HEX files, MAP files to detail memory usage and symbol reference, absolute LST files that contain source lines and generated machine code and COFF files for debugging.

The MPASM Assembler features include:

- Integration into MPLAB IDE projects
- User-defined macros to streamline assembly code
- Conditional assembly for multi-purpose source files
- Directives that allow complete control over the assembly process

## 9.5 MPLINK Object Linker/ MPLIB Object Librarian

The MPLINK Object Linker combines relocatable objects created by the MPASM Assembler and the MPLAB C18 C Compiler. It can link relocatable objects from precompiled libraries, using directives from a linker script.

The MPLIB Object Librarian manages the creation and modification of library files of precompiled code. When a routine from a library is called from a source file, only the modules that contain that routine will be linked in with the application. This allows large libraries to be used efficiently in many different applications.

The object linker/librarian features include:

- Efficient linking of single libraries instead of many smaller files
- Enhanced code maintainability by grouping related modules together
- Flexible creation of libraries with easy module listing, replacement, deletion and extraction

## 9.6 MPLAB Assembler, Linker and Librarian for Various Device Families

MPLAB Assembler produces relocatable machine code from symbolic assembly language for PIC24, PIC32 and dsPIC devices. MPLAB C Compiler uses the assembler to produce its object file. The assembler generates relocatable object files that can then be archived or linked with other relocatable object files and archives to create an executable file. Notable features of the assembler include:

- Support for the entire device instruction set
- Support for fixed-point and floating-point data
- Command line interface
- Rich directive set
- Flexible macro language
- MPLAB IDE compatibility

## 9.7 MPLAB SIM Software Simulator

The MPLAB SIM Software Simulator allows code development in a PC-hosted environment by simulating the PIC MCUs and dsPIC<sup>®</sup> DSCs on an instruction level. On any given instruction, the data areas can be examined or modified and stimuli can be applied from a comprehensive stimulus controller. Registers can be logged to files for further run-time analysis. The trace buffer and logic analyzer display extend the power of the simulator to record and track program execution, actions on I/O, most peripherals and internal registers.

The MPLAB SIM Software Simulator fully supports symbolic debugging using the MPLAB C Compilers, and the MPASM and MPLAB Assemblers. The software simulator offers the flexibility to develop and debug code outside of the hardware laboratory environment, making it an excellent, economical software development tool.

## 9.8 MPLAB REAL ICE In-Circuit Emulator System

MPLAB REAL ICE In-Circuit Emulator System is Microchip's next generation high-speed emulator for Microchip Flash DSC and MCU devices. It debugs and programs PIC<sup>®</sup> Flash MCUs and dsPIC<sup>®</sup> Flash DSCs with the easy-to-use, powerful graphical user interface of the MPLAB Integrated Development Environment (IDE), included with each kit.

The emulator is connected to the design engineer's PC using a high-speed USB 2.0 interface and is connected to the target with either a connector compatible with in-circuit debugger systems (RJ11) or with the new high-speed, noise tolerant, Low-Voltage Differential Signal (LVDS) interconnection (CAT5).

The emulator is field upgradable through future firmware downloads in MPLAB IDE. In upcoming releases of MPLAB IDE, new devices will be supported, and new features will be added. MPLAB REAL ICE offers significant advantages over competitive emulators including low-cost, full-speed emulation, run-time variable watches, trace analysis, complex breakpoints, a ruggedized probe interface and long (up to three meters) interconnection cables.

## 9.9 MPLAB ICD 3 In-Circuit Debugger System

MPLAB ICD 3 In-Circuit Debugger System is Microchip's most cost effective high-speed hardware debugger/programmer for Microchip Flash Digital Signal Controller (DSC) and microcontroller (MCU) devices. It debugs and programs PIC<sup>®</sup> Flash microcontrollers and dsPIC<sup>®</sup> DSCs with the powerful, yet easy-to-use graphical user interface of MPLAB Integrated Development Environment (IDE).

The MPLAB ICD 3 In-Circuit Debugger probe is connected to the design engineer's PC using a high-speed USB 2.0 interface and is connected to the target with a connector compatible with the MPLAB ICD 2 or MPLAB REAL ICE systems (RJ-11). MPLAB ICD 3 supports all MPLAB ICD 2 headers.

## 9.10 PICkit 3 In-Circuit Debugger/Programmer and PICkit 3 Debug Express

The MPLAB PICkit 3 allows debugging and programming of PIC<sup>®</sup> and dsPIC<sup>®</sup> Flash microcontrollers at a most affordable price point using the powerful graphical user interface of the MPLAB Integrated Development Environment (IDE). The MPLAB PICkit 3 is connected to the design engineer's PC using a full speed USB interface and can be connected to the target via a Microchip debug (RJ-11) connector (compatible with MPLAB ICD 3 and MPLAB REAL ICE). The connector uses two device I/O pins and the reset line to implement in-circuit debugging and In-Circuit Serial Programming<sup>™</sup>.

The PICkit 3 Debug Express include the PICkit 3, demo board and microcontroller, hookup cables and CDROM with user's guide, lessons, tutorial, compiler and MPLAB IDE software.

# PIC16C505

---

## 9.11 PICkit 2 Development Programmer/Debugger and PICkit 2 Debug Express

The PICkit™ 2 Development Programmer/Debugger is a low-cost development tool with an easy to use interface for programming and debugging Microchip's Flash families of microcontrollers. The full featured Windows® programming interface supports baseline (PIC10F, PIC12F5xx, PIC16F5xx), midrange (PIC12F6xx, PIC16F), PIC18F, PIC24, dsPIC30, dsPIC33, and PIC32 families of 8-bit, 16-bit, and 32-bit microcontrollers, and many Microchip Serial EEPROM products. With Microchip's powerful MPLAB Integrated Development Environment (IDE) the PICkit™ 2 enables in-circuit debugging on most PIC® microcontrollers. In-Circuit-Debugging runs, halts and single steps the program while the PIC microcontroller is embedded in the application. When halted at a breakpoint, the file registers can be examined and modified.

The PICkit 2 Debug Express include the PICkit 2, demo board and microcontroller, hookup cables and CDROM with user's guide, lessons, tutorial, compiler and MPLAB IDE software.

## 9.12 MPLAB PM3 Device Programmer

The MPLAB PM3 Device Programmer is a universal, CE compliant device programmer with programmable voltage verification at VDDMIN and VDDMAX for maximum reliability. It features a large LCD display (128 x 64) for menus and error messages and a modular, detachable socket assembly to support various package types. The ICSP™ cable assembly is included as a standard item. In Stand-Alone mode, the MPLAB PM3 Device Programmer can read, verify and program PIC devices without a PC connection. It can also set code protection in this mode. The MPLAB PM3 connects to the host PC via an RS-232 or USB cable. The MPLAB PM3 has high-speed communications and optimized algorithms for quick programming of large memory devices and incorporates an MMC card for file storage and data applications.

## 9.13 Demonstration/Development Boards, Evaluation Kits, and Starter Kits

A wide variety of demonstration, development and evaluation boards for various PIC MCUs and dsPIC DSCs allows quick application development on fully functional systems. Most boards include prototyping areas for adding custom circuitry and provide application firmware and source code for examination and modification.

The boards support a variety of features, including LEDs, temperature sensors, switches, speakers, RS-232 interfaces, LCD displays, potentiometers and additional EEPROM memory.

The demonstration and development boards can be used in teaching environments, for prototyping custom circuits and for learning about various microcontroller applications.

In addition to the PICDEM™ and dsPICDEM™ demonstration/development board series of circuits, Microchip has a line of evaluation kits and demonstration software for analog filter design, KEELOQ® security ICs, CAN, IrDA®, PowerSmart battery management, SEEVAL® evaluation system, Sigma-Delta ADC, flow rate sensing, plus many more.

Also available are starter kits that contain everything needed to experience the specified device. This usually includes a single application and debug capability, all on one board.

Check the Microchip web page ([www.microchip.com](http://www.microchip.com)) for the complete list of demonstration, development and evaluation kits.

## 10.0 ELECTRICAL CHARACTERISTICS - PIC16C505

### Absolute Maximum Ratings†

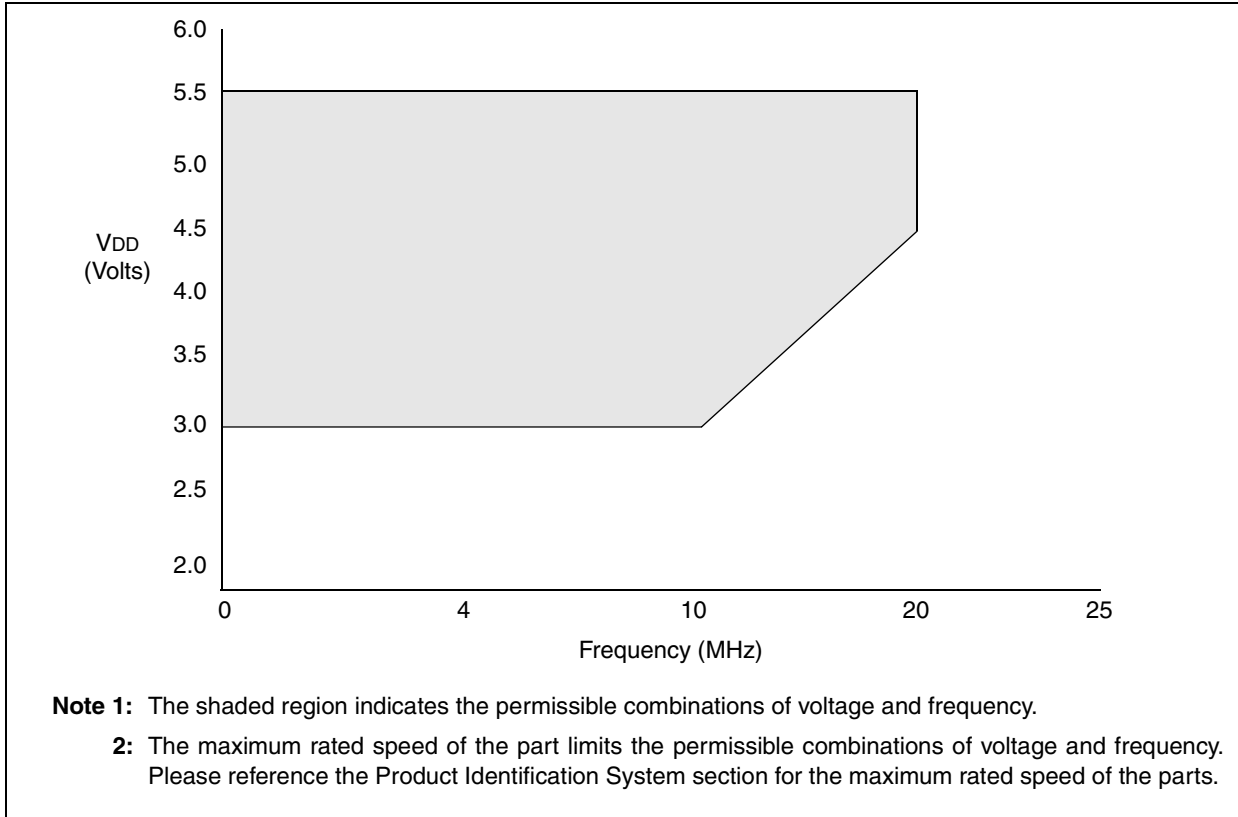
Ambient Temperature under bias .....	-40°C to +125°C
Storage Temperature .....	-65°C to +150°C
Voltage on VDD with respect to VSS .....	0 to +7 V
Voltage on $\overline{MCLR}$ with respect to VSS.....	0 to +14 V
Voltage on all other pins with respect to VSS .....	-0.6 V to (VDD + 0.6 V)
Total Power Dissipation <sup>(1)</sup> .....	700 mW
Max. Current out of VSS pin .....	150 mA
Max. Current into VDD pin .....	125 mA
Input Clamp Current, I <sub>IK</sub> (V <sub>I</sub> < 0 or V <sub>I</sub> > VDD).....	±20 mA
Output Clamp Current, I <sub>OK</sub> (V <sub>O</sub> < 0 or V <sub>O</sub> > VDD).....	±20 mA
Max. Output Current sunk by any I/O pin .....	25 mA
Max. Output Current sourced by any I/O pin.....	25 mA
Max. Output Current sourced by I/O port .....	100 mA
Max. Output Current sunk by I/O port .....	100 mA

**Note 1:** Power Dissipation is calculated as follows:  $P_{DIS} = V_{DD} \times \{I_{DD} - \sum I_{OH}\} + \sum \{(V_{DD}-V_{OH}) \times I_{OH}\} + \sum (V_{OL} \times I_{OL})$

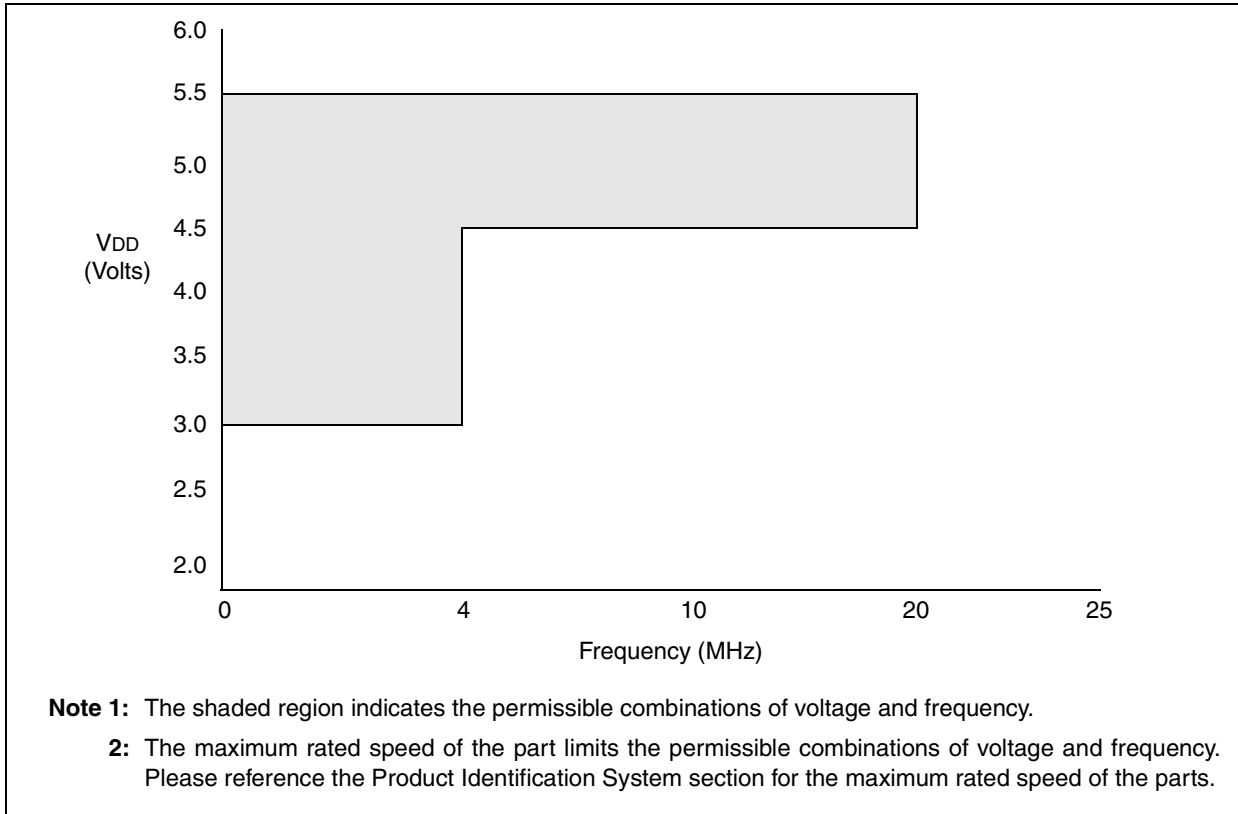
†NOTICE: Stresses above those listed under "Maximum Ratings" may cause permanent damage to the device. This is a stress rating only and functional operation of the device at those or any other conditions above those indicated in the operation listings of this specification is not implied. Exposure to maximum rating conditions for extended periods may affect device reliability.

# PIC16C505

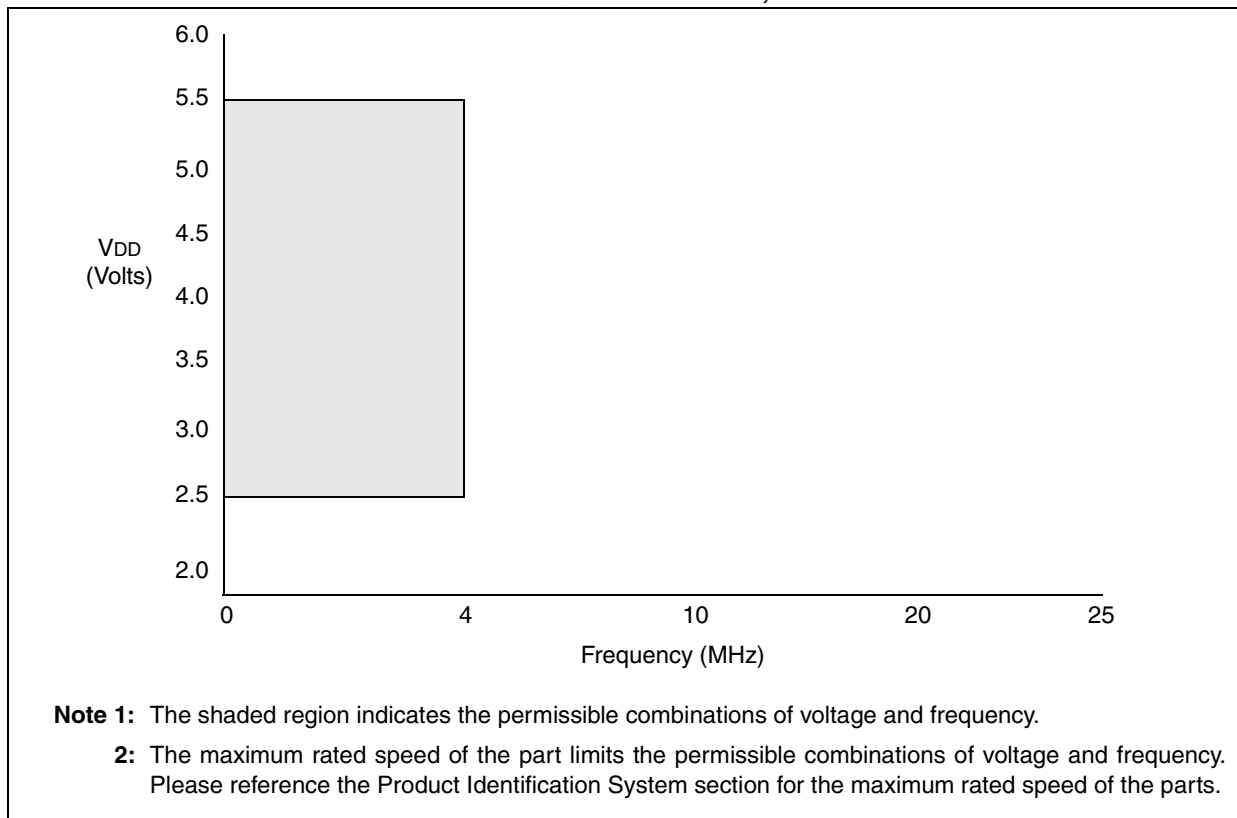
**FIGURE 10-1: PIC16C505 VOLTAGE-FREQUENCY GRAPH,  $0^{\circ}\text{C} \leq T_A \leq +70^{\circ}\text{C}$**



**FIGURE 10-2: PIC16C505 VOLTAGE-FREQUENCY GRAPH,  $-40^{\circ}\text{C} \leq T_A \leq 0^{\circ}\text{C}$ ,  $+70^{\circ}\text{C} \leq T_A \leq +125^{\circ}\text{C}$**



**FIGURE 10-3: PIC16LC505 VOLTAGE-FREQUENCY GRAPH,  $-40^{\circ}\text{C} \leq T_A \leq +85^{\circ}\text{C}$**



# PIC16C505

## 10.1 DC CHARACTERISTICS: PIC16C505-04 (Commercial, Industrial, Extended) PIC16C505-20(Commercial, Industrial, Extended)

DC Characteristics Power Supply Pins		Standard Operating Conditions (unless otherwise specified)					
		Operating Temperature					
		0°C ≤ TA ≤ +70°C (commercial)		-40°C ≤ TA ≤ +85°C (industrial)		-40°C ≤ TA ≤ +125°C (extended)	
Parm. No.	Characteristic	Sym	Min	Typ <sup>(1)</sup>	Max	Units	Conditions
D001	Supply Voltage	VDD	3.0		5.5	V	See Figure 10-1 through Figure 10-3
D002	RAM Data Retention Voltage <sup>(2)</sup>	VDR	—	1.5*	—	V	Device in SLEEP mode
D003	VDD Start Voltage to ensure Power-on Reset	VPOR	—	VSS	—	V	See section on Power-on Reset for details
D004	VDD Rise Rate to ensure Power-on Reset	SVDD	0.05*	—	—	V/ms	See section on Power-on Reset for details
D010	Supply Current <sup>(3)</sup>	IDD	—	0.8 — — — —	1.4 1.0 7 12 16 27	mA mA mA mA mA μA	FOSC = 4MHz, VDD = 5.5V, WDT disabled (Note 4)* FOSC = 4MHz, VDD = 3.0V, WDT disabled (Note 4) FOSC = 10MHz, VDD = 3.0V, WDT disabled (Note 6) FOSC = 20MHz, VDD = 4.5V, WDT disabled FOSC = 20MHz, VDD = 5.5V, WDT disabled* FOSC = 32kHz, VDD = 3.0V, WDT disabled (Note 6)
D020	Power-Down Current <sup>(5)</sup>	IPD	—	0.25 — — —	4 5.5 8 14	μA μA μA μA	VDD = 3.0V (Note 6) VDD = 4.5V* (Note 6) VDD = 5.5V, Industrial VDD = 5.5V, Extended Temp.
D022	WDT Current <sup>(5)</sup>	ΔIWDT	—	2.2	5	μA	VDD = 3.0V (Note 6)
1A	LP Oscillator Operating Frequency	Fosc	0	—	200	kHz	All temperatures
	RC Oscillator Operating Frequency		0	—	4	MHz	All temperatures
	XT Oscillator Operating Frequency		0	—	4	MHz	All temperatures
	HS Oscillator Operating Frequency		0	—	20	MHz	All temperatures

\* These parameters are characterized but not tested.

- Note 1:** Data in the Typical ("Typ") column is based on characterization results at 25°C. This data is for design guidance only and is not tested.
- 2:** This is the limit to which VDD can be lowered in SLEEP mode without losing RAM data.
- 3:** The supply current is mainly a function of the operating voltage and frequency. Other factors such as bus loading, oscillator type, bus rate, internal code execution pattern and temperature also have an impact on the current consumption.
- a) The test conditions for all IDD measurements in active operation mode are:  
OSC1 = external square wave, from rail-to-rail; all I/O pins tristated, pulled to VSS, T0CKI = VDD, MCLR = VDD;  
WDT enabled/disabled as specified.
- b) For standby current measurements, the conditions are the same, except that the device is in SLEEP mode.
- 4:** Does not include current through Rext. The current through the resistor can be estimated by the formula:  
 $I_R = V_{DD}/2R_{ext}$  (mA) with Rext in kOhm.
- 5:** The power down current in SLEEP mode does not depend on the oscillator type. Power down current is measured with the part in SLEEP mode, with all I/O pins in hi-impedance state and tied to VDD or VSS.
- 6:** Commercial temperature range only.

## 10.2 DC CHARACTERISTICS: PIC16LC505-04 (Commercial, Industrial)

DC Characteristics Power Supply Pins			Standard Operating Conditions (unless otherwise specified) Operating Temperature 0°C ≤ TA ≤ +70°C (commercial) -40°C ≤ TA ≤ +85°C (industrial)				
Parm. No.	Characteristic	Sym	Min	Typ <sup>(1)</sup>	Max	Units	Conditions
D001	Supply Voltage	VDD	2.5	—	5.5	V	See Figure 10-1 through Figure 10-3
D002	RAM Data Retention Voltage <sup>(2)</sup>	VDR	—	1.5*	—	V	Device in SLEEP mode
D003	VDD Start Voltage to ensure Power-on Reset	VPOR	—	VSS	—	V	See section on Power-on Reset for details
D004	VDD Rise Rate to ensure Power-on Reset	SVDD	0.05*	—	—	V/ms	See section on Power-on Reset for details
D010	Supply Current <sup>(3)</sup>	IDD	—	0.8	1.4	mA	FOSC = 4MHz, VDD = 5.5V, WDT disabled (Note 4)*
			—	0.4	0.8	mA	FOSC = 4MHz, VDD = 2.5V, WDT disabled (Note 4)
			—	15	23	μA	FOSC = 32kHz, VDD = 2.5V, WDT disabled (Note 6)
D020	Power-Down Current <sup>(5)</sup>	IPD	—	0.25	3	μA	VDD = 2.5V (Note 6)
			—	0.25	4	μA	VDD = 3.0V* (Note 6)
			—	3	8	μA	VDD = 5.5V Industrial
D022	WDT Current <sup>(5)</sup>	ΔI <sub>WDT</sub>	—	2.0	4	μA	VDD = 2.5V (Note 6)
1A	LP Oscillator Operating Frequency	FOSC	0	—	200	kHz	All temperatures
	RC Oscillator Operating Frequency		0	—	4	MHz	All temperatures
	XT Oscillator Operating Frequency		0	—	4	MHz	All temperatures
	HS Oscillator Operating Frequency		0	—	4	MHz	All temperatures

\* These parameters are characterized but not tested.

- Note 1:** Data in the Typical ("Typ") column is based on characterization results at 25°C. This data is for design guidance only and is not tested.
- 2:** This is the limit to which VDD can be lowered in SLEEP mode without losing RAM data.
- 3:** The supply current is mainly a function of the operating voltage and frequency. Other factors such as bus loading, oscillator type, bus rate, internal code execution pattern and temperature also have an impact on the current consumption.
- a) The test conditions for all IDD measurements in active operation mode are:  
OSC1 = external square wave, from rail-to-rail; all I/O pins tristated, pulled to VSS, T0CKI = VDD, MCLR = VDD;  
WDT enabled/disabled as specified.
- b) For standby current measurements, the conditions are the same, except that the device is in SLEEP mode.
- 4:** Does not include current through Rext. The current through the resistor can be estimated by the formula:  
IR = VDD/2Rext (mA) with Rext in kOhm.
- 5:** The power down current in SLEEP mode does not depend on the oscillator type. Power down current is measured with the part in SLEEP mode, with all I/O pins in hi-impedance state and tied to VDD or VSS.
- 6:** Commercial temperature range only.

# PIC16C505

## 10.3 DC CHARACTERISTICS: PIC16C505-04 (Commercial, Industrial, Extended) PIC16C505-20(Commercial, Industrial, Extended) PIC16LC505-04 (Commercial, Industrial)

Standard Operating Conditions (unless otherwise specified)							
Operating temperature $0^{\circ}\text{C} \leq T_A \leq +70^{\circ}\text{C}$ (commercial) $-40^{\circ}\text{C} \leq T_A \leq +85^{\circ}\text{C}$ (industrial) $-40^{\circ}\text{C} \leq T_A \leq +125^{\circ}\text{C}$ (extended)							
Operating voltage VDD range as described in DC spec Section 10.1 and Section 10.3.							
Param No.	Characteristic	Sym	Min	Typ†	Max	Units	Conditions
D030 D030A D031 D032 D033	Input Low Voltage I/O ports with TTL buffer with Schmitt Trigger buffer MCLR, RC5/T0CKI (in EXTRC mode) OSC1 (in XT, HS and LP)	V <sub>IL</sub>	V <sub>SS</sub> V <sub>SS</sub> V <sub>SS</sub> V <sub>SS</sub> V <sub>SS</sub>	— — — — —	0.8V 0.15V <sub>DD</sub> 0.2V <sub>DD</sub> 0.2V <sub>DD</sub> 0.3V <sub>DD</sub>	V V V V V	For all $4.5 \leq V_{DD} \leq 5.5\text{V}$ otherwise Note1
D040 D040A D041 D042 D042A D043	Input High Voltage I/O ports with TTL buffer with Schmitt Trigger buffer MCLR, RC5/T0CKI OSC1 (XT, HS and LP) OSC1 (in EXTRC mode)	V <sub>IH</sub>	2.0 0.25V <sub>DD</sub> + 0.8V <sub>DD</sub> 0.8V <sub>DD</sub> 0.7V <sub>DD</sub> 0.9V <sub>DD</sub>	— — — — — —	V <sub>DD</sub> V <sub>DD</sub> V <sub>DD</sub> V <sub>DD</sub> V <sub>DD</sub> V <sub>DD</sub>	V V V V V V	$4.5 \leq V_{DD} \leq 5.5\text{V}$ otherwise For entire VDD range Note1
D070	GPIO weak pull-up current (Note 4)	IPUR	50	250	400	μA	V <sub>DD</sub> = 5V, V <sub>PIN</sub> = V <sub>SS</sub>
D060 D061 D061A D063	Input Leakage Current (Notes 2, 3) I/O ports GP3/ $\overline{\text{MCLR}}$ (Note 5) GP3/ $\overline{\text{MCLR}}$ (Note 6) OSC1	I <sub>IL</sub>	— — — —	— — — —	±1 ±30 ±5 ±5	μA μA μA μA	V <sub>SS</sub> ≤ V <sub>PIN</sub> ≤ V <sub>DD</sub> , Pin at hi-impedance V <sub>SS</sub> ≤ V <sub>PIN</sub> ≤ V <sub>DD</sub> V <sub>SS</sub> ≤ V <sub>PIN</sub> ≤ V <sub>DD</sub> V <sub>SS</sub> ≤ V <sub>PIN</sub> ≤ V <sub>DD</sub> , XT, HS and LP osc configuration
D080 D080A D083 D083A	Output Low Voltage I/O ports/CLKOUT OSC2	V <sub>OL</sub>	— — — —	— — — —	0.6 0.6 0.6 0.6	V V V V	I <sub>OL</sub> = 8.5 mA, V <sub>DD</sub> = 4.5V, -40°C to +85°C I <sub>OL</sub> = 7.0 mA, V <sub>DD</sub> = 4.5V, -40°C to +125°C I <sub>OL</sub> = 1.6 mA, V <sub>DD</sub> = 4.5V, -40°C to +85°C I <sub>OL</sub> = 1.2 mA, V <sub>DD</sub> = 4.5V, -40°C to +125°C

† Data in "Typ" column is at 5V, 25°C unless otherwise stated. These parameters are for design guidance only and are not tested.

- Note 1:** In EXTRC oscillator configuration, the OSC1/CLKIN pin is a Schmitt Trigger input. It is not recommended that the PIC16C505 be driven with external clock in RC mode.
- 2:** The leakage current on the  $\overline{\text{MCLR}}$  pin is strongly dependent on the applied voltage level. The specified levels represent normal operating conditions. Higher leakage current may be measured at different input voltages.
- 3:** Negative current is defined as coming out of the pin.
- 4:** Does not include GP3. For GP3 see parameters D061 and D061A.
- 5:** This spec. applies to GP3/ $\overline{\text{MCLR}}$  configured as external  $\overline{\text{MCLR}}$  and GP3/ $\overline{\text{MCLR}}$  configured as input with internal pull-up enabled.
- 6:** This spec. applies when GP3/ $\overline{\text{MCLR}}$  is configured as an input with pull-up disabled. The leakage current of the  $\overline{\text{MCLR}}$  circuit is higher than the standard I/O logic.

Standard Operating Conditions (unless otherwise specified)							
<b>DC CHARACTERISTICS</b> Operating temperature $0^{\circ}\text{C} \leq T_A \leq +70^{\circ}\text{C}$ (commercial) $-40^{\circ}\text{C} \leq T_A \leq +85^{\circ}\text{C}$ (industrial) $-40^{\circ}\text{C} \leq T_A \leq +125^{\circ}\text{C}$ (extended) Operating voltage $V_{DD}$ range as described in DC spec Section 10.1 and Section 10.3.							
Param No.	Characteristic	Sym	Min	Typ†	Max	Units	Conditions
D090	Output High Voltage I/O ports/CLKOUT (Note 3)	VOH	$V_{DD} - 0.7$	—	—	V	$I_{OH} = -3.0\text{ mA}$ , $V_{DD} = 4.5\text{V}$ , $-40^{\circ}\text{C}$ to $+85^{\circ}\text{C}$
D090A			$V_{DD} - 0.7$	—	—	V	$I_{OH} = -2.5\text{ mA}$ , $V_{DD} = 4.5\text{V}$ , $-40^{\circ}\text{C}$ to $+125^{\circ}\text{C}$
D092	OSC2		$V_{DD} - 0.7$	—	—	V	$I_{OH} = -1.3\text{ mA}$ , $V_{DD} = 4.5\text{V}$ , $-40^{\circ}\text{C}$ to $+85^{\circ}\text{C}$
D092A			$V_{DD} - 0.7$	—	—	V	$I_{OH} = -1.0\text{ mA}$ , $V_{DD} = 4.5\text{V}$ , $-40^{\circ}\text{C}$ to $+125^{\circ}\text{C}$
D100	Capacitive Loading Specs on Output Pins OSC2 pin	COSC2	—	—	15	pF	In XT, HS and LP modes when external clock is used to drive OSC1.
D101	All I/O pins and OSC2	CIO	—	—	50	pF	

† Data in "Typ" column is at 5V, 25°C unless otherwise stated. These parameters are for design guidance only and are not tested.

- Note 1:** In EXTRC oscillator configuration, the OSC1/CLKIN pin is a Schmitt Trigger input. It is not recommended that the PIC16C505 be driven with external clock in RC mode.
- 2:** The leakage current on the  $\overline{\text{MCLR}}$  pin is strongly dependent on the applied voltage level. The specified levels represent normal operating conditions. Higher leakage current may be measured at different input voltages.
- 3:** Negative current is defined as coming out of the pin.
- 4:** Does not include GP3. For GP3 see parameters D061 and D061A.
- 5:** This spec. applies to GP3/ $\overline{\text{MCLR}}$  configured as external  $\overline{\text{MCLR}}$  and GP3/ $\overline{\text{MCLR}}$  configured as input with internal pull-up enabled.
- 6:** This spec. applies when GP3/ $\overline{\text{MCLR}}$  is configured as an input with pull-up disabled. The leakage current of the  $\overline{\text{MCLR}}$  circuit is higher than the standard I/O logic.

# PIC16C505

TABLE 10-1: PULL-UP RESISTOR RANGES - PIC16C505

VDD (Volts)	Temperature (°C)	Min	Typ	Max	Units
<b>RB0/RB1/RB4</b>					
2.5	-40	38K	42K	63K	W
	25	42K	48K	63K	W
	85	42K	49K	63K	W
	125	50K	55K	63K	W
5.5	-40	15K	17K	20K	W
	25	18K	20K	23K	W
	85	19K	22K	25K	W
	125	22K	24K	28K	W
<b>RB3</b>					
2.5	-40	285K	346K	417K	W
	25	343K	414K	532K	W
	85	368K	457K	532K	W
	125	431K	504K	593K	W
5.5	-40	247K	292K	360K	W
	25	288K	341K	437K	W
	85	306K	371K	448K	W
	125	351K	407K	500K	W

\* These parameters are characterized but not tested.

## 10.4 Timing Parameter Symbology and Load Conditions - PIC16C505

The timing parameter symbols have been created following one of the following formats:

1. TppS2ppS
2. TppS

<b>T</b>			
F	Frequency	T	Time

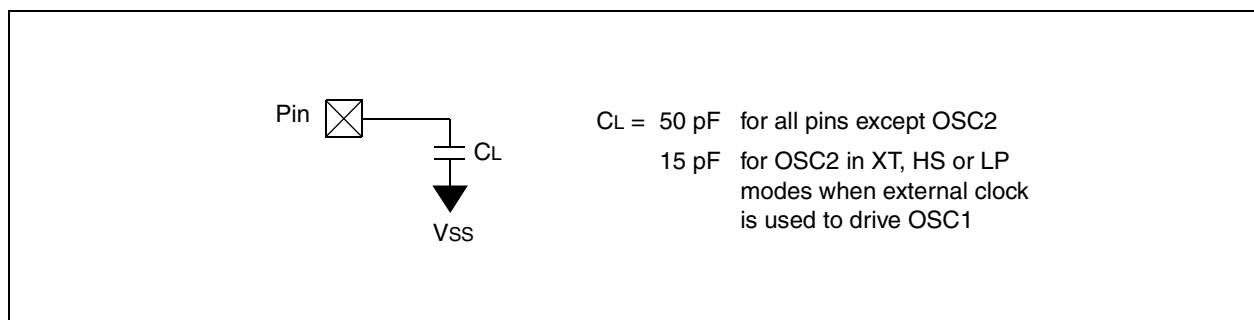
Lowercase subscripts (pp) and their meanings:

<b>pp</b>			
2	to	mc	$\overline{\text{MCLR}}$
ck	CLKOUT	osc	oscillator
cy	cycle time	os	OSC1
drt	device reset timer	t0	T0CKI
io	I/O port	wdt	watchdog timer

Uppercase letters and their meanings:

<b>S</b>			
F	Fall	P	Period
H	High	R	Rise
I	Invalid (Hi-impedance)	V	Valid
L	Low	Z	Hi-impedance

**FIGURE 10-4: LOAD CONDITIONS - PIC16C505**



# PIC16C505

## 10.5 Timing Diagrams and Specifications

FIGURE 10-5: EXTERNAL CLOCK TIMING - PIC16C505

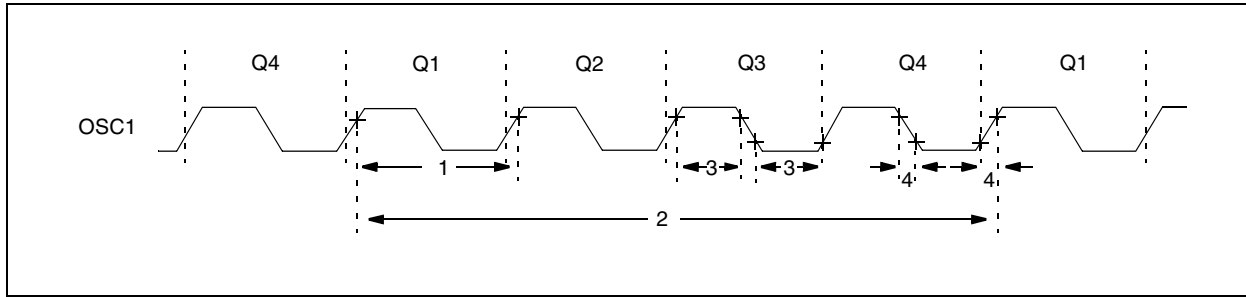


TABLE 10-2: EXTERNAL CLOCK TIMING REQUIREMENTS - PIC16C505

AC Characteristics		Standard Operating Conditions (unless otherwise specified)					
		Operating Temperature 0°C ≤ TA ≤ +70°C (commercial), -40°C ≤ TA ≤ +85°C (industrial), -40°C ≤ TA ≤ +125°C (extended)					
		Operating Voltage VDD range is described in Section 10.1					
Parameter No.	Sym	Characteristic	Min	Typ <sup>(1)</sup>	Max	Units	Conditions
1A	Fosc	External CLKIN Frequency <sup>(2)</sup>	DC	—	4	MHz	XT osc mode
			DC	—	4	MHz	HS osc mode (PIC16C505-04)
			DC	—	20	MHz	HS osc mode (PIC16C505-20)
			DC	—	200	kHz	LP osc mode
		Oscillator Frequency <sup>(2)</sup>	DC	—	4	MHz	EXTRC osc mode
			0.1	—	4	MHz	XT osc mode
			4	—	4	MHz	HS osc mode (PIC16C505-04)
			DC	—	200	kHz	LP osc mode
1	Tosc	External CLKIN Period <sup>(2)</sup>	250	—	—	ns	XT osc mode
			50	—	—	ns	HS osc mode (PIC16C505-20)
			—	—	—	μs	LP osc mode
		Oscillator Period <sup>(2)</sup>	250	—	—	ns	EXTRC osc mode
			250	—	10,000	ns	XT osc mode
		Oscillator Period <sup>(2)</sup>	250	—	250	ns	HS ocs mode (PIC16C505-04)
			50	—	250	ns	HS ocs mode (PIC16C505-20)
			5	—	—	μs	LP osc mode
2	Tcy	Instruction Cycle Time	—	4/Fosc	DC	ns	
			200	—	—	ns	

\* These parameters are characterized but not tested.

**Note 1:** Data in the Typical ("Typ") column is at 5V, 25°C unless otherwise stated. These parameters are for design guidance only and are not tested.

**2:** All specified values are based on characterization data for that particular oscillator type under standard operating conditions with the device executing code. Exceeding these specified limits may result in an unstable oscillator operation and/or higher than expected current consumption.

When an external clock input is used, the "max" cycle time limit is "DC" (no clock) for all devices.

**TABLE 10-2: EXTERNAL CLOCK TIMING REQUIREMENTS - PIC16C505 (CONTINUED)**

AC Characteristics		Standard Operating Conditions (unless otherwise specified)					
		Operating Temperature $0^{\circ}\text{C} \leq T_A \leq +70^{\circ}\text{C}$ (commercial), $-40^{\circ}\text{C} \leq T_A \leq +85^{\circ}\text{C}$ (industrial), $-40^{\circ}\text{C} \leq T_A \leq +125^{\circ}\text{C}$ (extended)					
		Operating Voltage VDD range is described in Section 10.1					
Parameter No.	Sym	Characteristic	Min	Typ <sup>(1)</sup>	Max	Units	Conditions
3	TosL, TosH	Clock in (OSC1) Low or High Time	50*	—	—	ns	XT oscillator
			2*	—	—	μs	LP oscillator
			10	—	—	ns	HS oscillator
4	TosR, TosF	Clock in (OSC1) Rise or Fall Time	—	—	25*	ns	XT oscillator
			—	—	50*	ns	LP oscillator
			—	—	15	ns	HS oscillator

\* These parameters are characterized but not tested.

**Note 1:** Data in the Typical ("Typ") column is at 5V, 25°C unless otherwise stated. These parameters are for design guidance only and are not tested.

**2:** All specified values are based on characterization data for that particular oscillator type under standard operating conditions with the device executing code. Exceeding these specified limits may result in an unstable oscillator operation and/or higher than expected current consumption.

When an external clock input is used, the "max" cycle time limit is "DC" (no clock) for all devices.

**TABLE 10-3: CALIBRATED INTERNAL RC FREQUENCIES - PIC16C505**

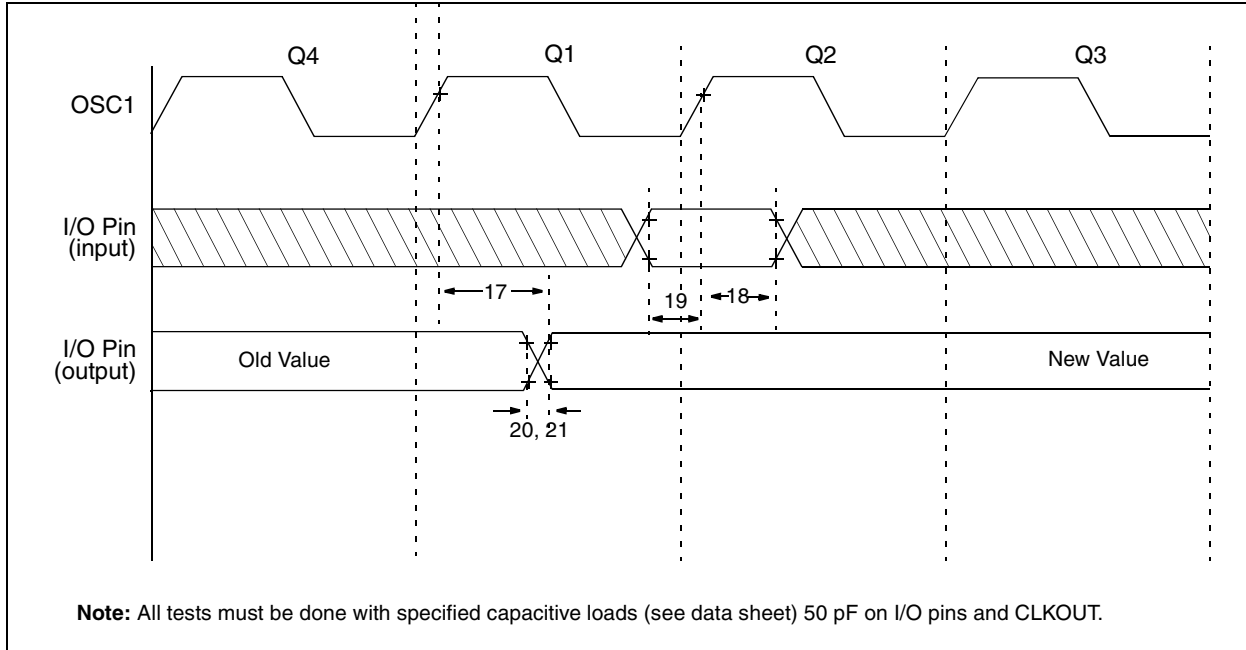
AC Characteristics		Standard Operating Conditions (unless otherwise specified)					
		Operating Temperature $0^{\circ}\text{C} \leq T_A \leq +70^{\circ}\text{C}$ (commercial), $-40^{\circ}\text{C} \leq T_A \leq +85^{\circ}\text{C}$ (industrial), $-40^{\circ}\text{C} \leq T_A \leq +125^{\circ}\text{C}$ (extended)					
		Operating Voltage VDD range is described in Section 10.1					
Parameter No.	Sym	Characteristic	Min*	Typ <sup>(1)</sup>	Max*	Units	Conditions
		Internal Calibrated RC Frequency	3.65	4.00	4.28	MHz	VDD = 5.0V
		Internal Calibrated RC Frequency	3.55	4.00	4.31	MHz	VDD = 2.5V

\* These parameters are characterized but not tested.

**Note 1:** Data in the Typical ("Typ") column is at 5V, 25°C unless otherwise stated. These parameters are for design guidance only and are not tested.

# PIC16C505

**FIGURE 10-6: I/O TIMING - PIC16C505**



**TABLE 10-4: TIMING REQUIREMENTS - PIC16C505**

AC Characteristics		Standard Operating Conditions (unless otherwise specified)				
		Operating Temperature 0°C ≤ TA ≤ +70°C (commercial) -40°C ≤ TA ≤ +85°C (industrial) -40°C ≤ TA ≤ +125°C (extended)				
		Operating Voltage VDD range is described in Section 10.1				
Parameter No.	Sym	Characteristic	Min	Typ <sup>(1)</sup>	Max	Units
17	TosH2ioV	OSC1↑ (Q1 cycle) to Port out valid <sup>(2,3)</sup>	—	—	100*	ns
18	TosH2ioI	OSC1↑ (Q2 cycle) to Port input invalid (I/O in hold time) <sup>(2)</sup>	TBD	—	—	ns
19	TioV2osH	Port input valid to OSC1↑ (I/O in setup time)	TBD	—	—	ns
20	TioR	Port output rise time <sup>(3)</sup>	—	10	25**	ns
21	TioF	Port output fall time <sup>(3)</sup>	—	10	25**	ns

\* These parameters are characterized but not tested.

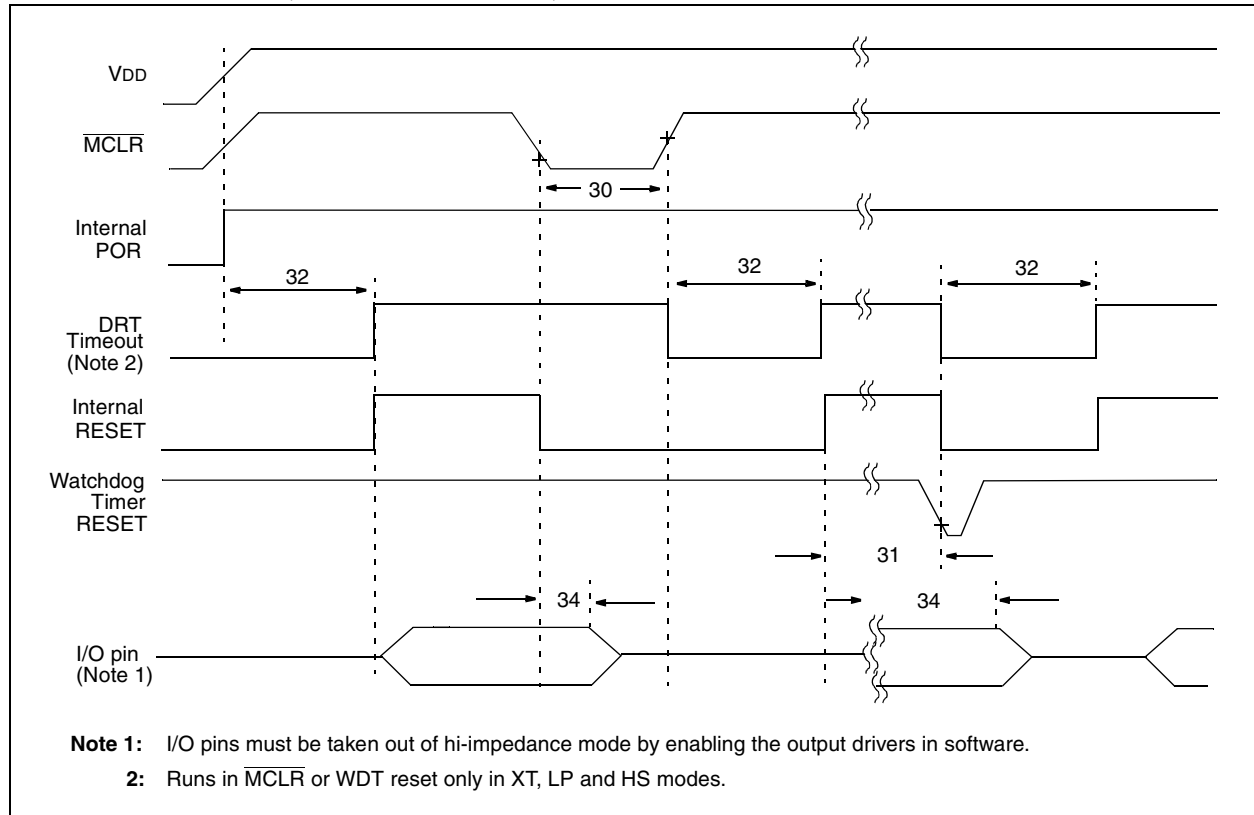
\*\* These parameters are design targets and are not tested.

**Note 1:** Data in the Typical ("Typ") column is at 5V, 25°C unless otherwise stated. These parameters are for design guidance only and are not tested.

**2:** Measurements are taken in EXTRC mode.

**3:** See Figure 10-4 for loading conditions.

**FIGURE 10-7: RESET, WATCHDOG TIMER, AND DEVICE RESET TIMER TIMING - PIC16C505**



**TABLE 10-5: RESET, WATCHDOG TIMER, AND DEVICE RESET TIMER - PIC16C505**

AC Characteristics Standard Operating Conditions (unless otherwise specified)							
Operating Temperature $0^{\circ}\text{C} \leq T_A \leq +70^{\circ}\text{C}$ (commercial) $-40^{\circ}\text{C} \leq T_A \leq +85^{\circ}\text{C}$ (industrial) $-40^{\circ}\text{C} \leq T_A \leq +125^{\circ}\text{C}$ (extended)							
Operating Voltage $V_{DD}$ range is described in Section 10.1							
Parameter No.	Sym	Characteristic	Min	Typ <sup>(1)</sup>	Max	Units	Conditions
30	Tmcl	$\overline{\text{MCLR}}$ Pulse Width (low)	2000*	—	—	ns	$V_{DD} = 5.0\text{ V}$
31	Twdt	Watchdog Timer Time-out Period (No Prescaler)	9*	18*	30*	ms	$V_{DD} = 5.0\text{ V}$ (Commercial)
32	TDRT	Device Reset Timer Period(2)	9*	18*	30*	ms	$V_{DD} = 5.0\text{ V}$ (Commercial)
34	Tioz	I/O Hi-impedance from $\overline{\text{MCLR}}$ Low	—	—	2000*	ns	

\* These parameters are characterized but not tested.

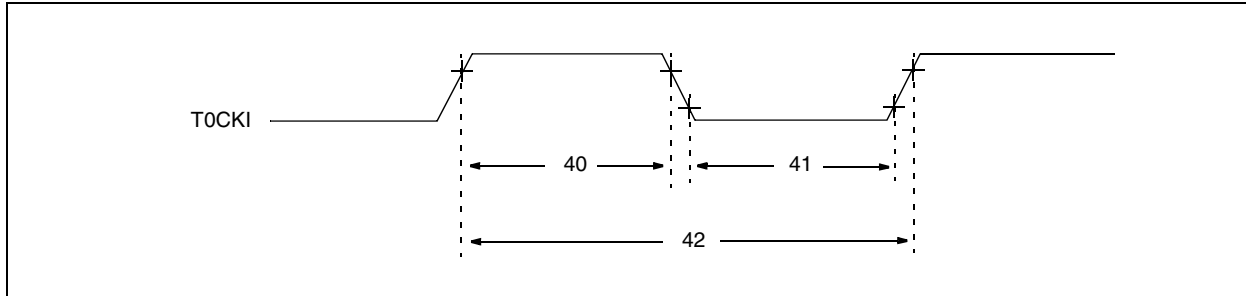
**Note 1:** Data in the Typical ("Typ") column is at 5V, 25°C unless otherwise stated. These parameters are for design guidance only and are not tested.

**TABLE 10-6: DRT (DEVICE RESET TIMER PERIOD - PIC16C505**

Oscillator Configuration	POR Reset	Subsequent Resets
IntRC & ExtRC	18 ms (typical)	300 $\mu\text{s}$ (typical)
XT, HS & LP	18 ms (typical)	18 ms (typical)

# PIC16C505

**FIGURE 10-8: TIMER0 CLOCK TIMINGS - PIC16C505**



**TABLE 10-7: TIMER0 CLOCK REQUIREMENTS - PIC16C505**

AC Characteristics		Standard Operating Conditions (unless otherwise specified)					
		Operating Temperature $0^{\circ}\text{C} \leq T_A \leq +70^{\circ}\text{C}$ (commercial) $-40^{\circ}\text{C} \leq T_A \leq +85^{\circ}\text{C}$ (industrial) $-40^{\circ}\text{C} \leq T_A \leq +125^{\circ}\text{C}$ (extended) Operating Voltage $V_{DD}$ range is described in Section 10.1.					
Parm No.	Sym	Characteristic	Min	Typ <sup>(1)</sup>	Max	Units	Conditions
40	Tt0H	T0CKI High Pulse Width	No Prescaler	$0.5 T_{CY} + 20^*$	—	—	ns
			With Prescaler	$10^*$	—	—	ns
41	Tt0L	T0CKI Low Pulse Width	No Prescaler	$0.5 T_{CY} + 20^*$	—	—	ns
			With Prescaler	$10^*$	—	—	ns
42	Tt0P	T0CKI Period	$20$ or $T_{CY} + 40^* N$	—	—	ns	Whichever is greater. N = Prescale Value (1, 2, 4, ..., 256)

\* These parameters are characterized but not tested.

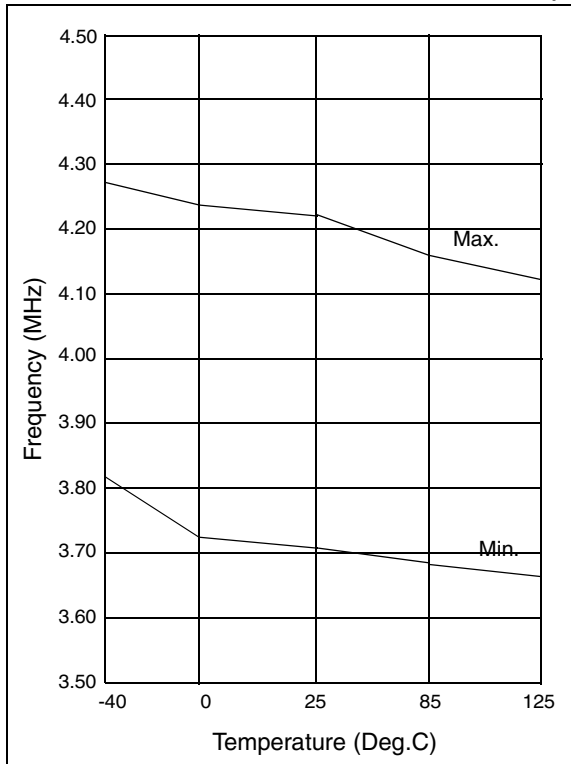
**Note 1:** Data in the Typical ("Typ") column is at 5V, 25°C unless otherwise stated. These parameters are for design guidance only and are not tested.

## 11.0 DC AND AC CHARACTERISTICS - PIC16C505

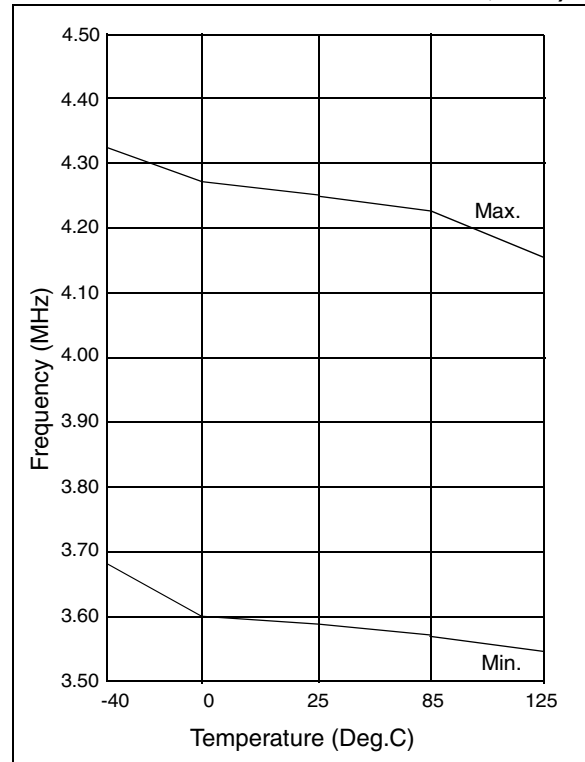
The graphs and tables provided in this section are for design guidance and are not tested. In some graphs or tables the data presented are outside specified operating range (e.g., outside specified VDD range). This is for information only and devices will operate properly only within the specified range.

The data presented in this section is a statistical summary of data collected on units from different lots over a period of time. "Typical" represents the mean of the distribution while "max" or "min" represents (mean + 3σ) and (mean - 3σ) respectively, where σ is standard deviation.

**FIGURE 11-1: CALIBRATED INTERNAL RC FREQUENCY RANGE VS. TEMPERATURE (VDD = 5.0V) (INTERNAL RC IS CALIBRATED TO 25°C, 5.0V)**



**FIGURE 11-2: CALIBRATED INTERNAL RC FREQUENCY RANGE VS. TEMPERATURE (VDD = 2.5V) (INTERNAL RC IS CALIBRATED TO 25°C, 5.0V)**



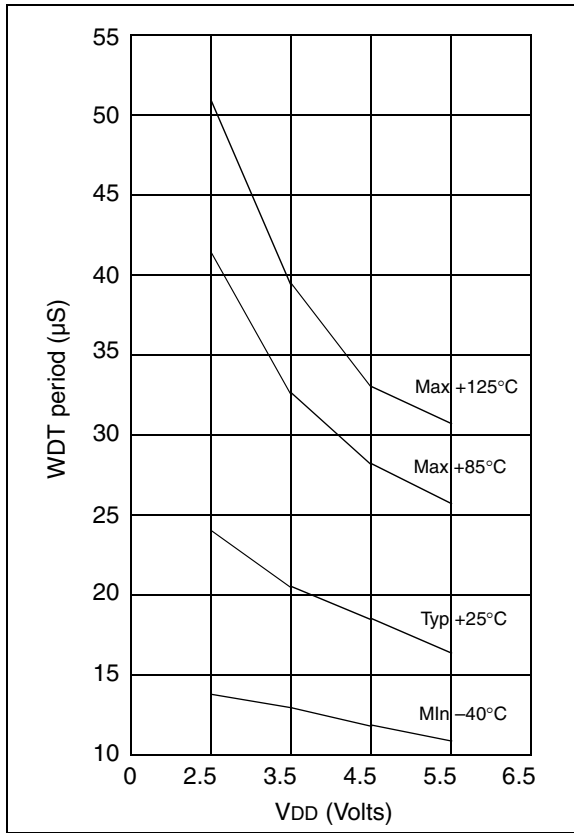
# PIC16C505

**TABLE 11-1: DYNAMIC I<sub>DD</sub> (TYPICAL) - WDT ENABLED, 25°C**

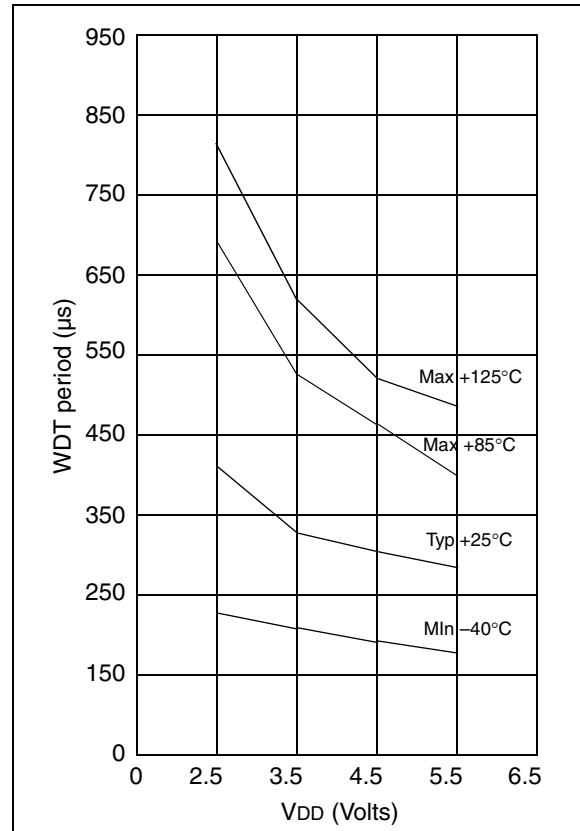
Oscillator	Frequency	V <sub>DD</sub> = 3.0V <sup>(1)</sup>	V <sub>DD</sub> = 5.5V
External RC	4 MHz	240 μA <sup>(2)</sup>	800 μA <sup>(2)</sup>
Internal RC	4 MHz	320 μA	800 μA
XT	4 MHz	300 μA	800 μA
LP	32 kHz	19 μA	50 μA
HS	20 MHz	N/A	4.5 mA

**Note 1:** LP oscillator based on V<sub>DD</sub> = 2.5V  
**2:** Does not include current through external R&C.

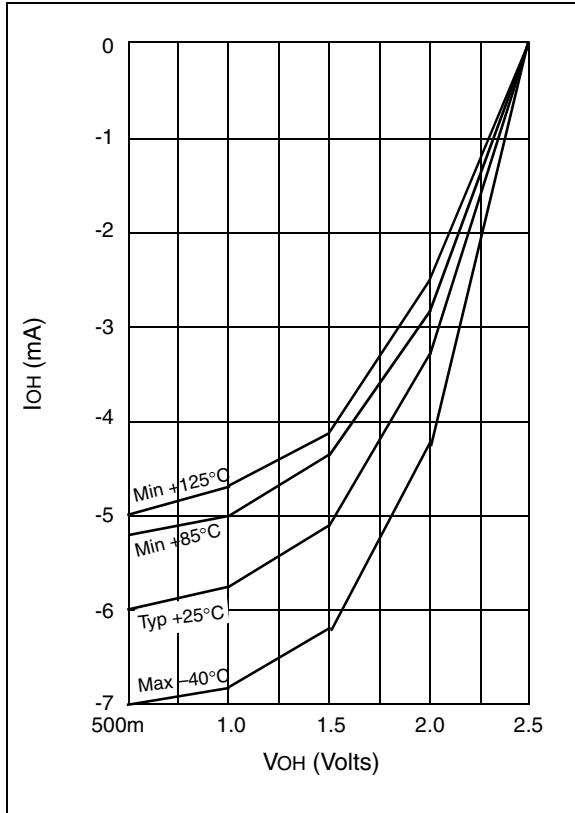
**FIGURE 11-3: WDT TIMER TIME-OUT PERIOD vs. V<sub>DD</sub>**



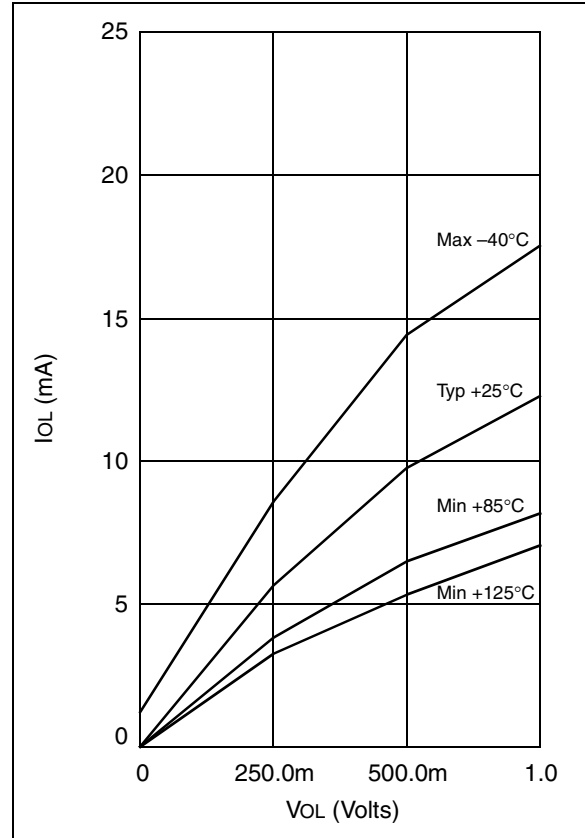
**FIGURE 11-4: SHORT DRT PERIOD VS. V<sub>DD</sub>**



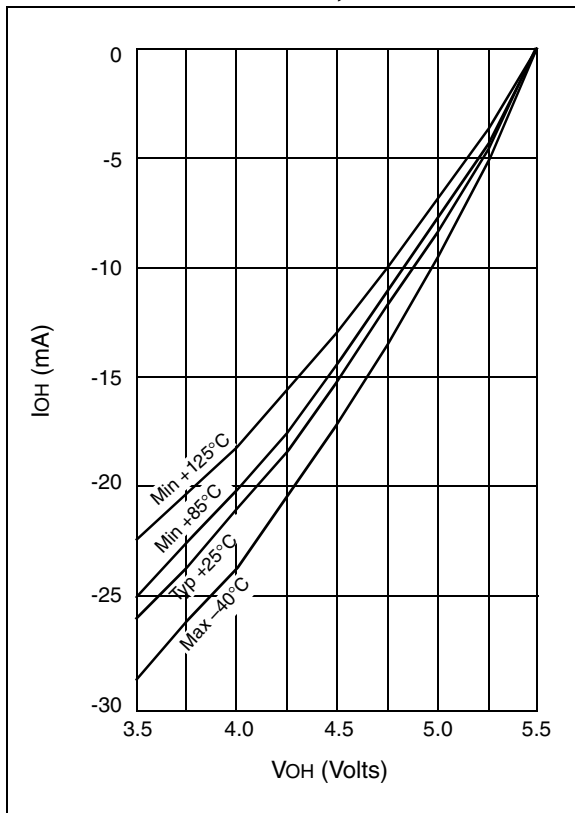
**FIGURE 11-5:  $I_{OH}$  vs.  $V_{OH}$ ,  $V_{DD} = 2.5\text{ V}$**



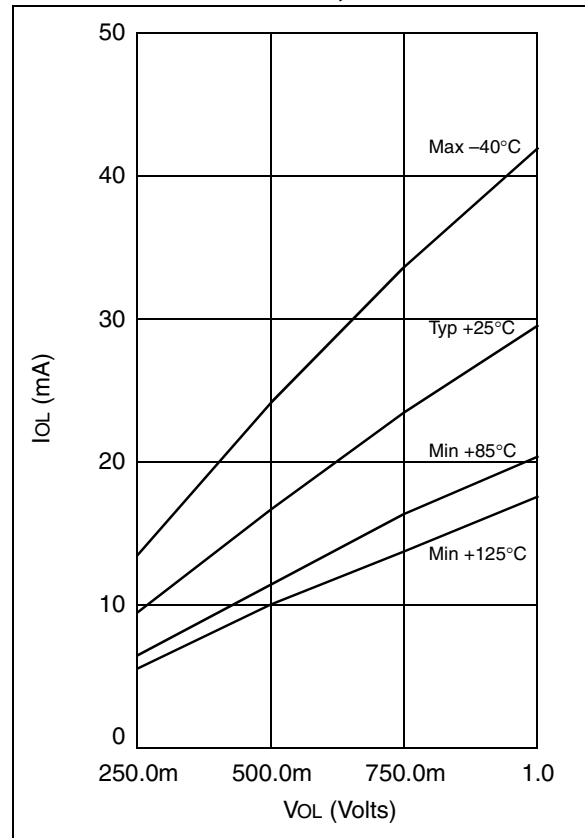
**FIGURE 11-7:  $I_{OL}$  vs.  $V_{OL}$ ,  $V_{DD} = 2.5\text{ V}$**



**FIGURE 11-6:  $I_{OH}$  vs.  $V_{OH}$ ,  $V_{DD} = 5.5\text{ V}$**



**FIGURE 11-8:  $I_{OL}$  vs.  $V_{OL}$ ,  $V_{DD} = 5.5\text{ V}$**



# PIC16C505

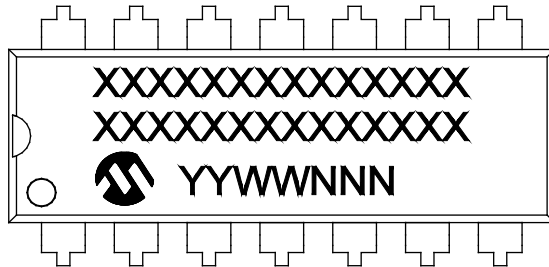
---

NOTES:

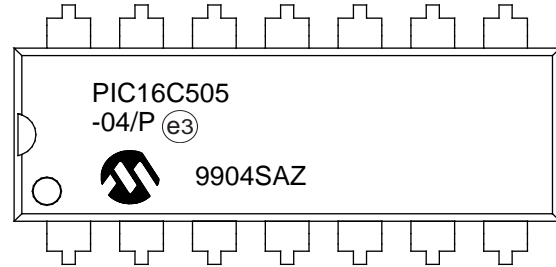
## 12.0 PACKAGING INFORMATION

### 12.1 Package Marking Information

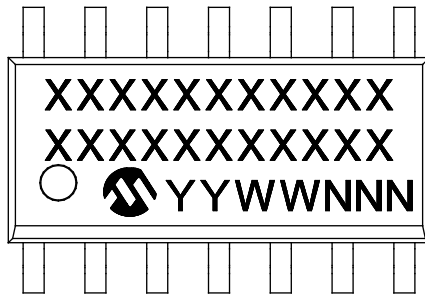
14-Lead PDIP (300 mil)



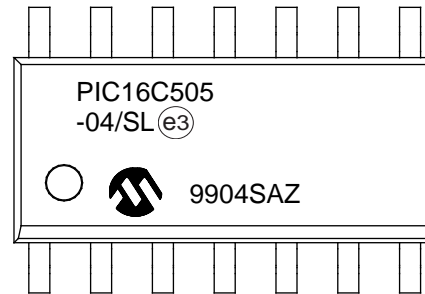
Example



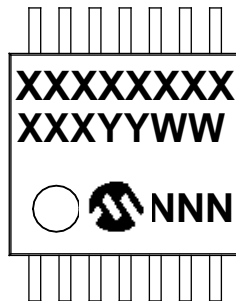
14-Lead SOIC (3.90 mm)



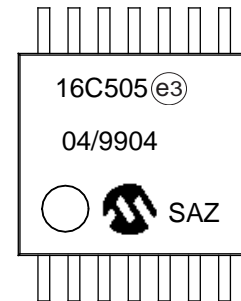
Example



14-Lead TSSOP (4.4 mm)



Example



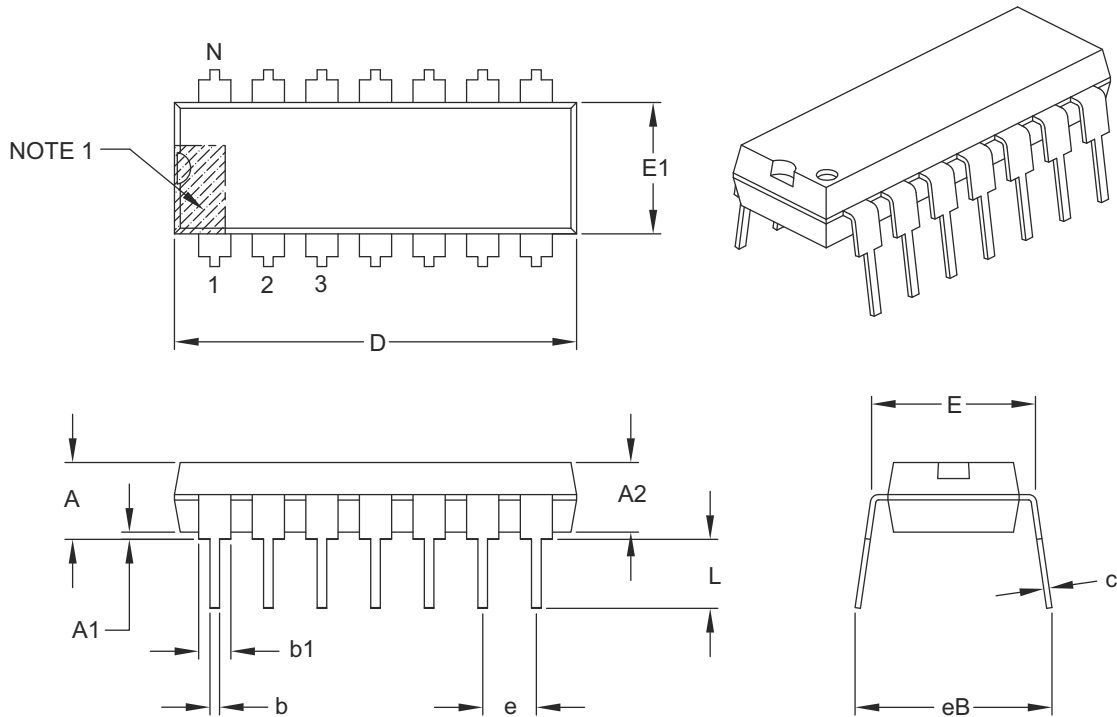
<b>Legend:</b>	XX...X	Customer-specific information
	Y	Year code (last digit of calendar year)
	YY	Year code (last 2 digits of calendar year)
	WW	Week code (week of January 1 is week '01')
	NNN	Alphanumeric traceability code
	(e3)	Pb-free JEDEC designator for Matte Tin (Sn)
	*	This package is Pb-free. The Pb-free JEDEC designator (e3) can be found on the outer packaging for this package.

**Note:** In the event the full Microchip part number cannot be marked on one line, it will be carried over to the next line, thus limiting the number of available characters for customer-specific information.

# PIC16C505

## 14-Lead Plastic Dual In-Line (P) – 300 mil Body [PDIP]

**Note:** For the most current package drawings, please see the Microchip Packaging Specification located at <http://www.microchip.com/packaging>



Dimension Limits	Units	INCHES		
		MIN	NOM	MAX
Number of Pins	N	14		
Pitch	e	.100 BSC		
Top to Seating Plane	A	–	–	.210
Molded Package Thickness	A2	.115	.130	.195
Base to Seating Plane	A1	.015	–	–
Shoulder to Shoulder Width	E	.290	.310	.325
Molded Package Width	E1	.240	.250	.280
Overall Length	D	.735	.750	.775
Tip to Seating Plane	L	.115	.130	.150
Lead Thickness	c	.008	.010	.015
Upper Lead Width	b1	.045	.060	.070
Lower Lead Width	b	.014	.018	.022
Overall Row Spacing §	eB	–	–	.430

**Notes:**

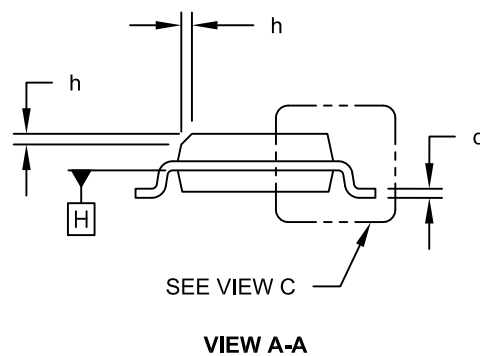
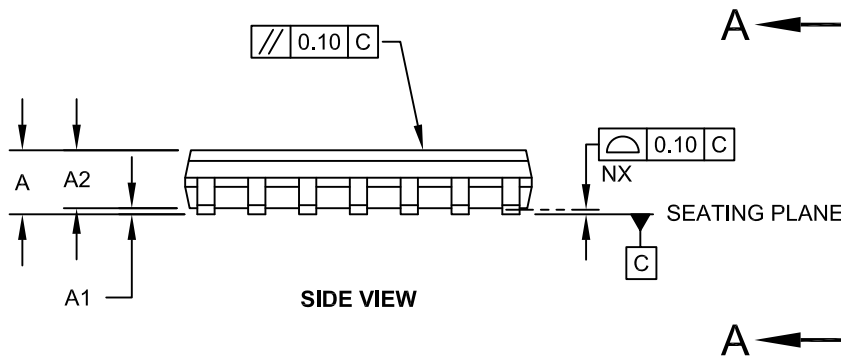
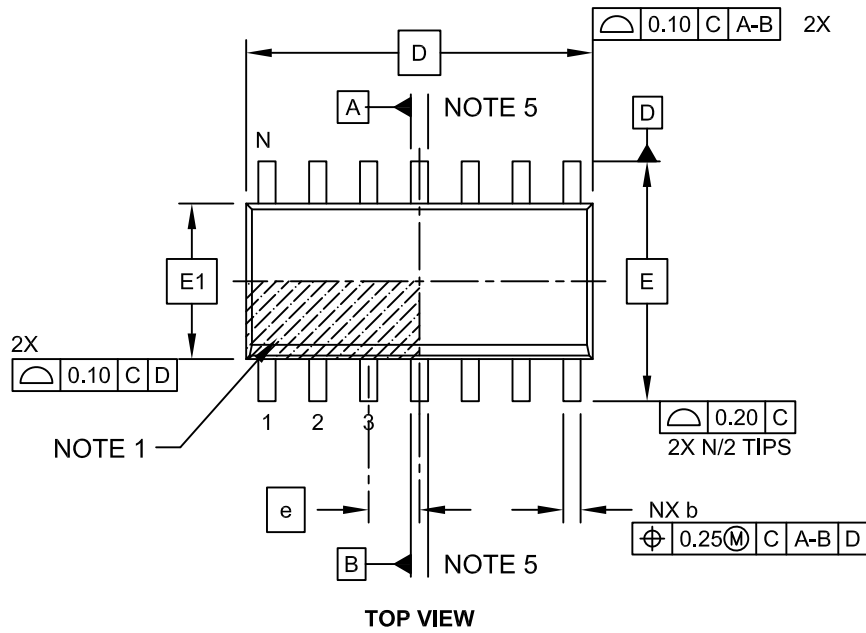
- Pin 1 visual index feature may vary, but must be located with the hatched area.
- § Significant Characteristic.
- Dimensions D and E1 do not include mold flash or protrusions. Mold flash or protrusions shall not exceed .010" per side.
- Dimensioning and tolerancing per ASME Y14.5M.

BSC: Basic Dimension. Theoretically exact value shown without tolerances.

Microchip Technology Drawing C04-005B

## 14-Lead Plastic Small Outline (SL) - Narrow, 3.90 mm Body [SOIC]

**Note:** For the most current package drawings, please see the Microchip Packaging Specification located at <http://www.microchip.com/packaging>

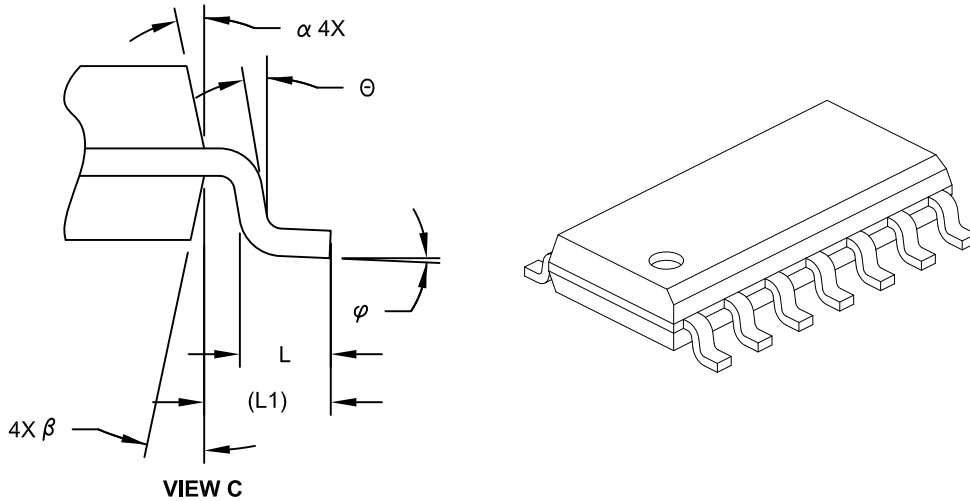


Microchip Technology Drawing No. C04-065C Sheet 1 of 2

# PIC16C505

## 14-Lead Plastic Small Outline (SL) - Narrow, 3.90 mm Body [SOIC]

**Note:** For the most current package drawings, please see the Microchip Packaging Specification located at <http://www.microchip.com/packaging>



		MILLIMETERS		
Units		MIN	NOM	MAX
Dimension Limits				
Number of Pins	N	14		
Pitch	e	1.27 BSC		
Overall Height	A	-	-	1.75
Molded Package Thickness	A2	1.25	-	-
Standoff §	A1	0.10	-	0.25
Overall Width	E	6.00 BSC		
Molded Package Width	E1	3.90 BSC		
Overall Length	D	8.65 BSC		
Chamfer (Optional)	h	0.25	-	0.50
Foot Length	L	0.40	-	1.27
Footprint	L1	1.04 REF		
Lead Angle	Θ	0°	-	-
Foot Angle	φ	0°	-	8°
Lead Thickness	c	0.10	-	0.25
Lead Width	b	0.31	-	0.51
Mold Draft Angle Top	α	5°	-	15°
Mold Draft Angle Bottom	β	5°	-	15°

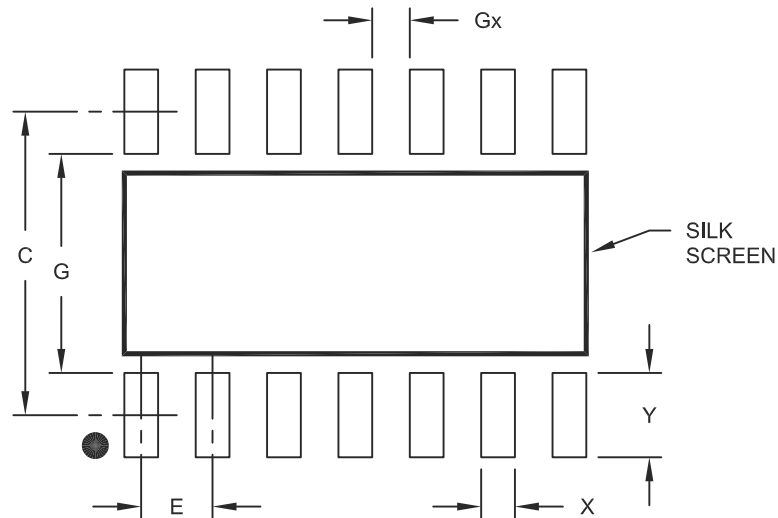
**Notes:**

- Pin 1 visual index feature may vary, but must be located within the hatched area.
- § Significant Characteristic
- Dimension D does not include mold flash, protrusions or gate burrs, which shall not exceed 0.15 mm per end. Dimension E1 does not include interlead flash or protrusion, which shall not exceed 0.25 mm per side.
- Dimensioning and tolerancing per ASME Y14.5M  
BSC: Basic Dimension. Theoretically exact value shown without tolerances.  
REF: Reference Dimension, usually without tolerance, for information purposes only.
- Datums A & B to be determined at Datum H.

Microchip Technology Drawing No. C04-065C Sheet 2 of 2

## 14-Lead Plastic Small Outline (SL) - Narrow, 3.90 mm Body [SOIC]

**Note:** For the most current package drawings, please see the Microchip Packaging Specification located at <http://www.microchip.com/packaging>



RECOMMENDED LAND PATTERN

Dimension Limits	Units	MILLIMETERS		
		MIN	NOM	MAX
Contact Pitch	E	1.27 BSC		
Contact Pad Spacing	C		5.40	
Contact Pad Width	X			0.60
Contact Pad Length	Y			1.50
Distance Between Pads	Gx	0.67		
Distance Between Pads	G	3.90		

**Notes:**

1. Dimensioning and tolerancing per ASME Y14.5M

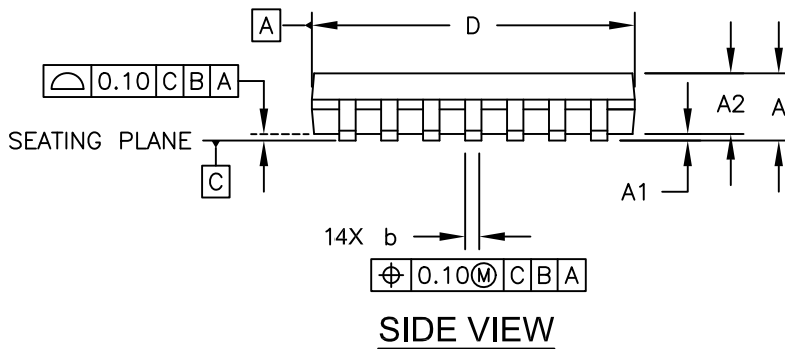
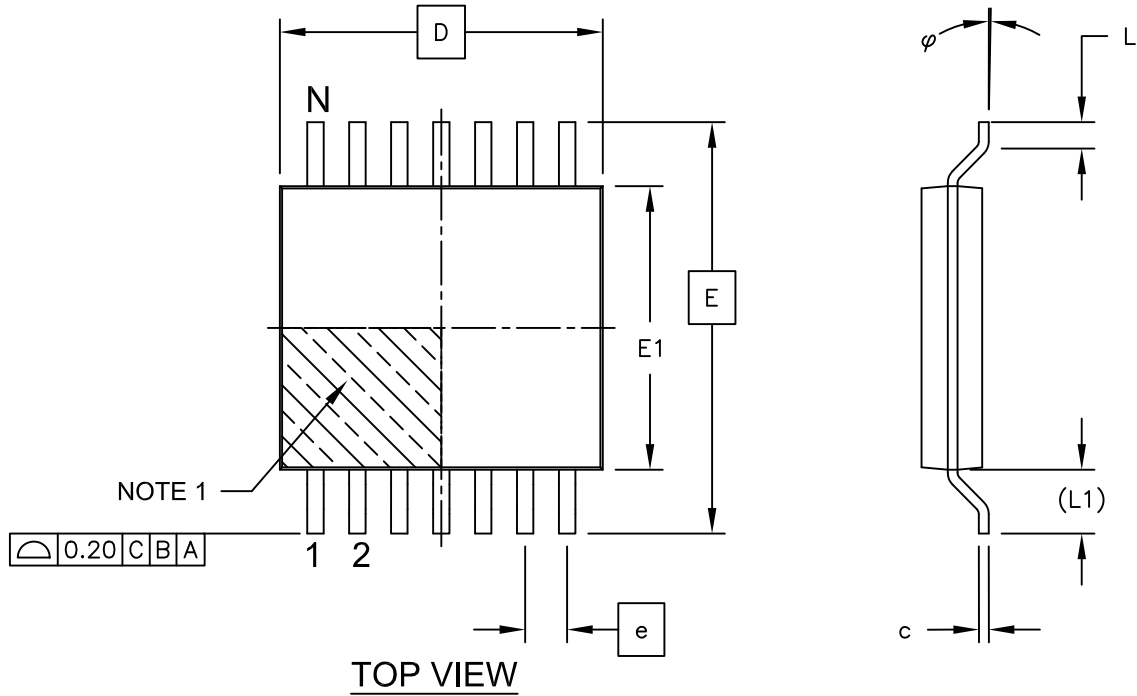
BSC: Basic Dimension. Theoretically exact value shown without tolerances.

Microchip Technology Drawing No. C04-2065A

# PIC16C505

## 14-Lead Plastic Thin Shrink Small Outline (ST) - 4.4 mm Body [TSSOP]

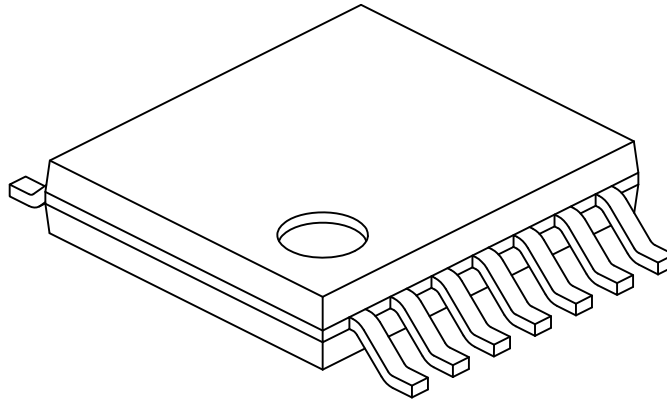
**Note:** For the most current package drawings, please see the Microchip Packaging Specification located at <http://www.microchip.com/packaging>



Microchip Technology Drawing C04-087C Sheet 1 of 2

## 14-Lead Plastic Thin Shrink Small Outline (ST) - 4.4 mm Body [TSSOP]

**Note:** For the most current package drawings, please see the Microchip Packaging Specification located at <http://www.microchip.com/packaging>



Dimension Limits	Units	MILLIMETERS		
		MIN	NOM	MAX
Number of Pins	N	14		
Pitch	e	0.65 BSC		
Overall Height	A	-	-	1.20
Molded Package Thickness	A2	0.80	1.00	1.05
Standoff	A1	0.05	-	0.15
Overall Width	E	6.40 BSC		
Molded Package Width	E1	4.30	4.40	4.50
Molded Package Length	D	4.90	5.00	5.10
Foot Length	L	0.45	0.60	0.75
Footprint	(L1)	1.00 REF		
Foot Angle	$\phi$	0°	-	8°
Lead Thickness	c	0.09	-	0.20
Lead Width	b	0.19	-	0.30

**Notes:**

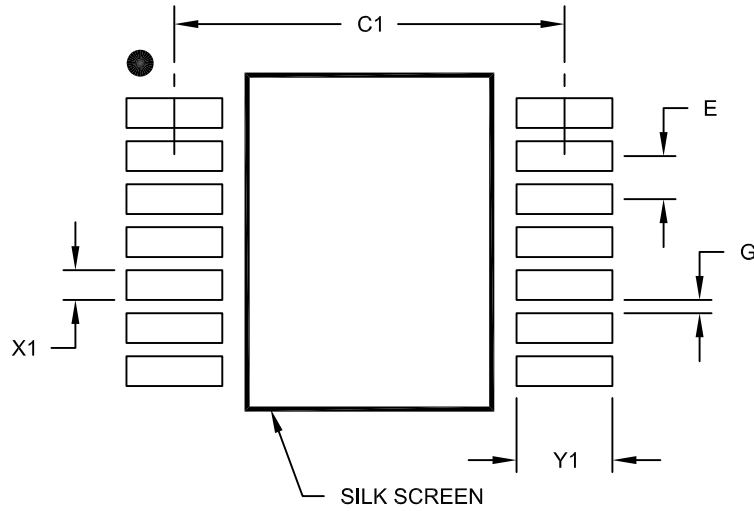
- Pin 1 visual index feature may vary, but must be located within the hatched area.
- Dimensions D and E1 do not include mold flash or protrusions. Mold flash or protrusions shall not exceed 0.15mm per side.
- Dimensioning and tolerancing per ASME Y14.5M
  - BSC: Basic Dimension. Theoretically exact value shown without tolerances.
  - REF: Reference Dimension, usually without tolerance, for information purposes only.

Microchip Technology Drawing No. C04-087C Sheet 2 of 2

# PIC16C505

## 14-Lead Plastic Thin Shrink Small Outline (ST) - 4.4 mm Body [TSSOP]

**Note:** For the most current package drawings, please see the Microchip Packaging Specification located at <http://www.microchip.com/packaging>



RECOMMENDED LAND PATTERN

Dimension Limits	Units	MILLIMETERS		
		MIN	NOM	MAX
Contact Pitch	E	0.65 BSC		
Contact Pad Spacing	C1		5.90	
Contact Pad Width (X14)	X1			0.45
Contact Pad Length (X14)	Y1			1.45
Distance Between Pads	G	0.20		

Notes:

1. Dimensioning and tolerancing per ASME Y14.5M

BSC: Basic Dimension. Theoretically exact value shown without tolerances.

Microchip Technology Drawing No. C04-2087A

## APPENDIX A: REVISION HISTORY

### Revision D (June 2012)

- **Section 12.0 “Packaging Information”** was updated with current package outline drawings.
- Removed Section 2.1 “UV Erasable Devices” section.

# PIC18F66K80 FAMILY

---

NOTES:

## INDEX

### A

ALU .....	7
Applications .....	3
Architectural Overview .....	7
Assembler	
MPASM Assembler .....	52

### B

Block Diagram	
On-Chip Reset Circuit .....	33
Timer0 .....	23
TMR0/WDT Prescaler .....	26
Watchdog Timer .....	35
Brown-Out Protection Circuit .....	36

### C

C Compilers	
MPLAB C18 .....	52
CAL0 bit .....	16
CAL1 bit .....	16
CAL2 bit .....	16
CAL3 bit .....	16
CALFST bit .....	16
CALSLW bit .....	16
Carry .....	7
Clocking Scheme .....	10
Code Protection .....	27, 37
Configuration Bits .....	27
Configuration Word .....	27
Customer Change Notification Service .....	85
Customer Notification Service .....	85
Customer Support .....	85

### D

DC and AC Characteristics .....	69
Development Support .....	51
Device Varieties .....	5
Digit Carry .....	7

### E

Errata .....	2
--------------	---

### F

Family of Devices	
PIC16C505 .....	4
FSR .....	18

### I

I/O Interfacing .....	19
I/O Ports .....	19
I/O Programming Considerations .....	20
ID Locations .....	27, 37
INDF .....	18
Indirect Data Addressing .....	18
Instruction Cycle .....	10
Instruction Flow/Pipelining .....	10
Instruction Set Summary .....	40
Internet Address .....	85

### L

Loading of PC .....	17
---------------------	----

### M

Memory Organization .....	11
Data Memory .....	12
Program Memory .....	11
Microchip Internet Web Site .....	85
MPLAB ASM30 Assembler, Linker, Librarian .....	52
MPLAB Integrated Development Environment Software .....	51
MPLAB PM3 Device Programmer .....	54
MPLAB REAL ICE In-Circuit Emulator System .....	53
MPLINK Object Linker/MPLIB Object Librarian .....	52

### O

OPTION Register .....	15
OSC selection .....	27
OSCCAL Register .....	16
Oscillator Configurations .....	28
Oscillator Types	
HS .....	28
LP .....	28
RC .....	28
XT .....	28

### P

Package Marking Information .....	73
Packaging Information .....	73
POR	
Device Reset Timer (DRT) .....	27, 34
$\overline{PD}$ .....	36
Power-On Reset (POR) .....	27
$\overline{TO}$ .....	36
PORTB .....	19
Power-Down Mode .....	37
Prescaler .....	26
Program Counter .....	17

### Q

Q cycles .....	10
----------------	----

### R

RC Oscillator .....	29
Read Modify Write .....	20
Reader Response .....	86
Register File Map .....	12
Registers	
Special Function .....	13
Reset .....	27
Reset on Brown-Out .....	36
Revision History .....	81

### S

SLEEP .....	27, 37
Software Simulator (MPLAB SIM) .....	53
Special Features of the CPU .....	27
Special Function Registers .....	13
Stack .....	17
STATUS .....	7
STATUS Register .....	14

### T

Timer0	
Switching Prescaler Assignment .....	26
Timer0 .....	23
Timer0 (TMR0) Module .....	23
TMR0 with External Clock .....	25
Timing Diagrams and Specifications .....	64
Timing Parameter Symbology and Load Conditions .....	63
TRIS Registers .....	19

# PIC16C505

---

## W

Wake-up from SLEEP .....	37
Watchdog Timer (WDT) .....	27, 34
Period .....	35
Programming Considerations .....	35
WWW Address .....	85
WWW, On-Line Support .....	2

## Z

Zero bit .....	7
----------------	---

## THE MICROCHIP WEB SITE

Microchip provides online support via our WWW site at [www.microchip.com](http://www.microchip.com). This web site is used as a means to make files and information easily available to customers. Accessible by using your favorite Internet browser, the web site contains the following information:

- **Product Support** – Data sheets and errata, application notes and sample programs, design resources, user's guides and hardware support documents, latest software releases and archived software
- **General Technical Support** – Frequently Asked Questions (FAQ), technical support requests, online discussion groups, Microchip consultant program member listing
- **Business of Microchip** – Product selector and ordering guides, latest Microchip press releases, listing of seminars and events, listings of Microchip sales offices, distributors and factory representatives

## CUSTOMER CHANGE NOTIFICATION SERVICE

Microchip's customer notification service helps keep customers current on Microchip products. Subscribers will receive e-mail notification whenever there are changes, updates, revisions or errata related to a specified product family or development tool of interest.

To register, access the Microchip web site at [www.microchip.com](http://www.microchip.com). Under "Support", click on "Customer Change Notification" and follow the registration instructions.

## CUSTOMER SUPPORT

Users of Microchip products can receive assistance through several channels:

- Distributor or Representative
- Local Sales Office
- Field Application Engineer (FAE)
- Technical Support

Customers should contact their distributor, representative or field application engineer (FAE) for support. Local sales offices are also available to help customers. A listing of sales offices and locations is included in the back of this document.

**Technical support is available through the web site at: <http://microchip.com/support>**

# PIC16C505

---

---

## READER RESPONSE

It is our intention to provide you with the best documentation possible to ensure successful use of your Microchip product. If you wish to provide your comments on organization, clarity, subject matter, and ways in which our documentation can better serve you, please FAX your comments to the Technical Publications Manager at (480) 792-4150.

Please list the following information, and use this outline to provide us with your comments about this document.

TO: Technical Publications Manager Total Pages Sent \_\_\_\_\_

RE: Reader Response

From: Name \_\_\_\_\_

Company \_\_\_\_\_

Address \_\_\_\_\_

City / State / ZIP / Country \_\_\_\_\_

Telephone: (\_\_\_\_\_) \_\_\_\_\_ - \_\_\_\_\_ FAX: (\_\_\_\_\_) \_\_\_\_\_ - \_\_\_\_\_

Application (optional):

Would you like a reply?  Y  N

Device: PIC16C505

Literature Number: DS40192D

Questions:

1. What are the best features of this document?

\_\_\_\_\_  
\_\_\_\_\_

2. How does this document meet your hardware and software development needs?

\_\_\_\_\_  
\_\_\_\_\_

3. Do you find the organization of this document easy to follow? If not, why?

\_\_\_\_\_  
\_\_\_\_\_

4. What additions to the document do you think would enhance the structure and subject?

\_\_\_\_\_  
\_\_\_\_\_

5. What deletions from the document could be made without affecting the overall usefulness?

\_\_\_\_\_  
\_\_\_\_\_

6. Is there any incorrect or misleading information (what and where)?

\_\_\_\_\_  
\_\_\_\_\_

7. How would you improve this document?

\_\_\_\_\_  
\_\_\_\_\_

## PIC16C505 Product Identification System

PART NO.	-XX	X	/XX	XXX		Examples	
					<b>Pattern:</b>	Special Requirements	a) PIC16C505-04/P Commercial Temp., PDIP Package, 4 MHz, normal VDD limits
					<b>Package:</b>	SL = 150 mil SOIC P = 300 mil PDIP ST = 4.4 mm TSSOP	b) PIC16C505-04I/SL Industrial Temp., SOIC package, 4 MHz, normal VDD limits
					<b>Temperature Range:</b>	- = 0°C to +70°C I = -40°C to +85°C E = -40°C to +125°C	c) PIC16C505-04I/P Industrial Temp., PDIP package, 4 MHz, normal VDD limits
					<b>Frequency Range:</b>	04 = 4 MHz (XT, INTRC, EXTRC OSC) 20 = 20 MHz (HS OSC)	
					<b>Device</b>	PIC16C505 PIC16LC505 PIC16C505T (Tape & reel for SOIC only) PIC16LC505T (Tape & reel for SOIC only)	

Please contact your local sales office for exact ordering procedures.

### **Sales and Support**

#### **Data Sheets**

Products supported by a preliminary Data Sheet may have an errata sheet describing minor operational differences and recommended workarounds. To determine if an errata sheet exists for a particular device, please contact one of the following:

1. Your local Microchip sales office
2. The Microchip Worldwide Site ([www.microchip.com](http://www.microchip.com))

Please specify which device, revision of silicon and Data Sheet (include Literature #) you are using.

#### **New Customer Notification System**

Register on our web site ([www.microchip.com/cn](http://www.microchip.com/cn)) to receive the most current information on our products.

# PIC16C505

---

NOTES:

---

**Note the following details of the code protection feature on Microchip devices:**

- Microchip products meet the specification contained in their particular Microchip Data Sheet.
- Microchip believes that its family of products is one of the most secure families of its kind on the market today, when used in the intended manner and under normal conditions.
- There are dishonest and possibly illegal methods used to breach the code protection feature. All of these methods, to our knowledge, require using the Microchip products in a manner outside the operating specifications contained in Microchip's Data Sheets. Most likely, the person doing so is engaged in theft of intellectual property.
- Microchip is willing to work with the customer who is concerned about the integrity of their code.
- Neither Microchip nor any other semiconductor manufacturer can guarantee the security of their code. Code protection does not mean that we are guaranteeing the product as “unbreakable.”

Code protection is constantly evolving. We at Microchip are committed to continuously improving the code protection features of our products. Attempts to break Microchip's code protection feature may be a violation of the Digital Millennium Copyright Act. If such acts allow unauthorized access to your software or other copyrighted work, you may have a right to sue for relief under that Act.

---

Information contained in this publication regarding device applications and the like is provided only for your convenience and may be superseded by updates. It is your responsibility to ensure that your application meets with your specifications. MICROCHIP MAKES NO REPRESENTATIONS OR WARRANTIES OF ANY KIND WHETHER EXPRESS OR IMPLIED, WRITTEN OR ORAL, STATUTORY OR OTHERWISE, RELATED TO THE INFORMATION, INCLUDING BUT NOT LIMITED TO ITS CONDITION, QUALITY, PERFORMANCE, MERCHANTABILITY OR FITNESS FOR PURPOSE. Microchip disclaims all liability arising from this information and its use. Use of Microchip devices in life support and/or safety applications is entirely at the buyer's risk, and the buyer agrees to defend, indemnify and hold harmless Microchip from any and all damages, claims, suits, or expenses resulting from such use. No licenses are conveyed, implicitly or otherwise, under any Microchip intellectual property rights.

**Trademarks**

The Microchip name and logo, the Microchip logo, dsPIC, KEELOQ, KEELOQ logo, MPLAB, PIC, PICmicro, PICSTART, PIC<sup>32</sup> logo, rfPIC and UNI/O are registered trademarks of Microchip Technology Incorporated in the U.S.A. and other countries.


FilterLab, Hampshire, HI-TECH C, Linear Active Thermistor, MXDEV, MXLAB, SEEVAL and The Embedded Control Solutions Company are registered trademarks of Microchip Technology Incorporated in the U.S.A.

Analog-for-the-Digital Age, Application Maestro, chipKIT, chipKIT logo, CodeGuard, dsPICDEM, dsPICDEM.net, dsPICworks, dsSPEAK, ECAN, ECONOMONITOR, FanSense, HI-TIDE, In-Circuit Serial Programming, ICSP, Mindi, MiWi, MPASM, MPLAB Certified logo, MPLIB, MPLINK, mTouch, Omniscient Code Generation, PICC, PICC-18, PICDEM, PICDEM.net, PICkit, PICtail, REAL ICE, rfLAB, Select Mode, Total Endurance, TSHARC, UniWinDriver, WiperLock and ZENA are trademarks of Microchip Technology Incorporated in the U.S.A. and other countries.

SQTP is a service mark of Microchip Technology Incorporated in the U.S.A.

All other trademarks mentioned herein are property of their respective companies.

© 1999-2012, Microchip Technology Incorporated, Printed in the U.S.A., All Rights Reserved.

 Printed on recycled paper.

ISBN: 978-1-62076-395-7

**QUALITY MANAGEMENT SYSTEM**  
**CERTIFIED BY DNV**  
**== ISO/TS 16949 ==**

*Microchip received ISO/TS-16949:2009 certification for its worldwide headquarters, design and wafer fabrication facilities in Chandler and Tempe, Arizona; Gresham, Oregon and design centers in California and India. The Company's quality system processes and procedures are for its PIC<sup>®</sup> MCUs and dsPIC<sup>®</sup> DSCs, KEELOQ<sup>®</sup> code hopping devices, Serial EEPROMs, microperipherals, nonvolatile memory and analog products. In addition, Microchip's quality system for the design and manufacture of development systems is ISO 9001:2000 certified.*



# MICROCHIP

## Worldwide Sales and Service

### AMERICAS

**Corporate Office**  
2355 West Chandler Blvd.  
Chandler, AZ 85224-6199  
Tel: 480-792-7200  
Fax: 480-792-7277  
Technical Support:  
<http://www.microchip.com/support>  
Web Address:  
[www.microchip.com](http://www.microchip.com)

**Atlanta**  
Duluth, GA  
Tel: 678-957-9614  
Fax: 678-957-1455

**Boston**  
Westborough, MA  
Tel: 774-760-0087  
Fax: 774-760-0088

**Chicago**  
Itasca, IL  
Tel: 630-285-0071  
Fax: 630-285-0075

**Cleveland**  
Independence, OH  
Tel: 216-447-0464  
Fax: 216-447-0643

**Dallas**  
Addison, TX  
Tel: 972-818-7423  
Fax: 972-818-2924

**Detroit**  
Farmington Hills, MI  
Tel: 248-538-2250  
Fax: 248-538-2260

**Indianapolis**  
Noblesville, IN  
Tel: 317-773-8323  
Fax: 317-773-5453

**Los Angeles**  
Mission Viejo, CA  
Tel: 949-462-9523  
Fax: 949-462-9608

**Santa Clara**  
Santa Clara, CA  
Tel: 408-961-6444  
Fax: 408-961-6445

**Toronto**  
Mississauga, Ontario,  
Canada  
Tel: 905-673-0699  
Fax: 905-673-6509

### ASIA/PACIFIC

**Asia Pacific Office**  
Suites 3707-14, 37th Floor  
Tower 6, The Gateway  
Harbour City, Kowloon  
Hong Kong  
Tel: 852-2401-1200  
Fax: 852-2401-3431

**Australia - Sydney**  
Tel: 61-2-9868-6733  
Fax: 61-2-9868-6755

**China - Beijing**  
Tel: 86-10-8569-7000  
Fax: 86-10-8528-2104

**China - Chengdu**  
Tel: 86-28-8665-5511  
Fax: 86-28-8665-7889

**China - Chongqing**  
Tel: 86-23-8980-9588  
Fax: 86-23-8980-9500

**China - Hangzhou**  
Tel: 86-571-2819-3187  
Fax: 86-571-2819-3189

**China - Hong Kong SAR**  
Tel: 852-2401-1200  
Fax: 852-2401-3431

**China - Nanjing**  
Tel: 86-25-8473-2460  
Fax: 86-25-8473-2470

**China - Qingdao**  
Tel: 86-532-8502-7355  
Fax: 86-532-8502-7205

**China - Shanghai**  
Tel: 86-21-5407-5533  
Fax: 86-21-5407-5066

**China - Shenyang**  
Tel: 86-24-2334-2829  
Fax: 86-24-2334-2393

**China - Shenzhen**  
Tel: 86-755-8203-2660  
Fax: 86-755-8203-1760

**China - Wuhan**  
Tel: 86-27-5980-5300  
Fax: 86-27-5980-5118

**China - Xian**  
Tel: 86-29-8833-7252  
Fax: 86-29-8833-7256

**China - Xiamen**  
Tel: 86-592-2388138  
Fax: 86-592-2388130

**China - Zhuhai**  
Tel: 86-756-3210040  
Fax: 86-756-3210049

### ASIA/PACIFIC

**India - Bangalore**  
Tel: 91-80-3090-4444  
Fax: 91-80-3090-4123

**India - New Delhi**  
Tel: 91-11-4160-8631  
Fax: 91-11-4160-8632

**India - Pune**  
Tel: 91-20-2566-1512  
Fax: 91-20-2566-1513

**Japan - Osaka**  
Tel: 81-66-152-7160  
Fax: 81-66-152-9310

**Japan - Yokohama**  
Tel: 81-45-471-6166  
Fax: 81-45-471-6122

**Korea - Daegu**  
Tel: 82-53-744-4301  
Fax: 82-53-744-4302

**Korea - Seoul**  
Tel: 82-2-554-7200  
Fax: 82-2-558-5932 or  
82-2-558-5934

**Malaysia - Kuala Lumpur**  
Tel: 60-3-6201-9857  
Fax: 60-3-6201-9859

**Malaysia - Penang**  
Tel: 60-4-227-8870  
Fax: 60-4-227-4068

**Philippines - Manila**  
Tel: 63-2-634-9065  
Fax: 63-2-634-9069

**Singapore**  
Tel: 65-6334-8870  
Fax: 65-6334-8850

**Taiwan - Hsin Chu**  
Tel: 886-3-5778-366  
Fax: 886-3-5770-955

**Taiwan - Kaohsiung**  
Tel: 886-7-536-4818  
Fax: 886-7-330-9305

**Taiwan - Taipei**  
Tel: 886-2-2500-6610  
Fax: 886-2-2508-0102

**Thailand - Bangkok**  
Tel: 66-2-694-1351  
Fax: 66-2-694-1350

### EUROPE

**Austria - Wels**  
Tel: 43-7242-2244-39  
Fax: 43-7242-2244-393

**Denmark - Copenhagen**  
Tel: 45-4450-2828  
Fax: 45-4485-2829

**France - Paris**  
Tel: 33-1-69-53-63-20  
Fax: 33-1-69-30-90-79

**Germany - Munich**  
Tel: 49-89-627-144-0  
Fax: 49-89-627-144-44

**Italy - Milan**  
Tel: 39-0331-742611  
Fax: 39-0331-466781

**Netherlands - Drunen**  
Tel: 31-416-690399  
Fax: 31-416-690340

**Spain - Madrid**  
Tel: 34-91-708-08-90  
Fax: 34-91-708-08-91

**UK - Wokingham**  
Tel: 44-118-921-5869  
Fax: 44-118-921-5820

11/29/11

Компания «Life Electronics» занимается поставками электронных компонентов импортного и отечественного производства от производителей и со складов крупных дистрибьюторов Европы, Америки и Азии.

С конца 2013 года компания активно расширяет линейку поставок компонентов по направлению коаксиальный кабель, кварцевые генераторы и конденсаторы (керамические, пленочные, электролитические), за счёт заключения дистрибьюторских договоров

Мы предлагаем:

- Конкурентоспособные цены и скидки постоянным клиентам.
- Специальные условия для постоянных клиентов.
- Подбор аналогов.
- Поставку компонентов в любых объемах, удовлетворяющих вашим потребностям.
- Приемлемые сроки поставки, возможна ускоренная поставка.
- Доставку товара в любую точку России и стран СНГ.
- Комплексную поставку.
- Работу по проектам и поставку образцов.
- Формирование склада под заказчика.
- Сертификаты соответствия на поставляемую продукцию (по желанию клиента).
- Тестирование поставляемой продукции.
- Поставку компонентов, требующих военную и космическую приемку.
- Входной контроль качества.
- Наличие сертификата ISO.

В составе нашей компании организован Конструкторский отдел, призванный помогать разработчикам, и инженерам.

Конструкторский отдел помогает осуществить:

- Регистрацию проекта у производителя компонентов.
- Техническую поддержку проекта.
- Защиту от снятия компонента с производства.
- Оценку стоимости проекта по компонентам.
- Изготовление тестовой платы монтаж и пусконаладочные работы.



Тел: +7 (812) 336 43 04 (многоканальный)  
Email: [org@lifeelectronics.ru](mailto:org@lifeelectronics.ru)