

MACX MCR-EX-SL-RPSS-2I-2I



2-channel repeater power supply, Ex i

Data sheet
105571_en_00

© PHOENIX CONTACT 2014-05-13

1 Description

The 2-channel repeater power supply is designed for the operation of intrinsically safe (Ex-i) 2-wire measuring transducers installed in the Ex area.

The 2-wire measuring transducers are supplied with power and analog 4...20 mA measured values from the Ex area are transferred to the non-Ex area.

The output of the module is active.

The analog measured value on the Ex or non-Ex side can be overlaid with digital (HART) communication signals and transmitted bidirectionally.

Sockets are integrated into the COMBICON connectors for connecting HART communicators.

The module is suitable for safety-related applications up to SIL 3 according to IEC/EN 61508.

Features

- 2-channel
- 4 ... 20 mA input, intrinsically safe, [Ex ia], powered
- 4 ... 20 mA output, active
- HART-compatible
- Error indication according to NAMUR NE 43
- Up to SIL 3 according to IEC/EN 61508
- 5-way electrical isolation
- Safe electrical isolation between inputs and outputs, supply
- Power supply possible via DIN rail connector
- Installation in Ex zone 2 permitted
- Plug-in connection terminal blocks, either screw or spring-cage connection technology (Push-in technology)
- Housing width of 12.5 mm
- Low power dissipation
- High transmission accuracy



WARNING: Explosion hazard

The device is an associated item of equipment (category 1) with "intrinsic safety" protection type and can be installed in zone 2 potentially explosive areas as a category 3 device. It meets the requirements of EN 60079-0:2009, EN 60079-11:2012, and EN 60079-15:2010.

When installing and operating the device, the applicable safety directives (including national safety directives), accident prevention regulations, as well as general technical regulations must be observed.



Make sure you always use the latest documentation.

It can be downloaded from the product at phoenixcontact.net/products.

This data sheet is valid for all products listed on the following page:

2 Table of contents

- 1 Description 1
- 2 Table of contents 2
- 3 Ordering data 3
- 4 Technical data 3
- 5 Safety regulations and installation notes 5
 - 5.1 Installation notes 5
 - 5.2 Intrinsic safety 5
 - 5.3 Installation in Zone 2 5
 - 5.4 Safety-related applications (SIL) 5
- 6 Installation 6
 - 6.1 Structure 6
 - 6.2 Basic circuit diagram with connection terminal blocks 6
 - 6.3 Dimensions 7
 - 6.4 Assembly 7
 - 6.5 Connecting the cables 8
 - 6.6 Power supply 9
- 7 Comparison of the safety data 9
- 8 Safety-related applications 10
 - 8.1 Safety characteristic data 10
 - 8.2 Conditions 11
 - 8.3 Installation and startup 11
 - 8.4 Notes on operation 11
 - 8.5 Recurring checks 12
 - 8.6 Repair 12
 - 8.7 Standards 12
 - 8.8 Abbreviations 13

3 Ordering data

Description	Type	Order No.	Pcs. / Pkt.
Ex i measuring transducer repeater power supply, 2-channel; HART-transparent. Supplies Ex i 2-wire measuring transducers and transmits the 4 - 20 mA signal from the Ex area to the safe area. 5-way electrical isolation, up to SIL 3 according to IEC 61508; screw connection.	MACX MCR-EX-SL-RPSS-2I-2I	2865382	1
Ex i measuring transducer repeater power supply, 2-channel; HART-transparent. Supplies Ex i 2-wire measuring transducers and transmits the 4 - 20 mA signal from the Ex area to the safe area. 5-way electrical isolation, up to SIL 3 according to IEC 61508; spring-cage connection.	MACX MCR-EX-SL-RPSS-2I-2I-SP	2924676	1
Accessories	Type	Order No.	Pcs. / Pkt.
DIN rail connector for DIN rail mounting. Universal for TBUS housing. Gold-plated contacts, 5-pos. Plug component	ME 6,2 TBUS-2 1,5/5-ST-3,81 GN	2869728	10
Power and error message module	MACX MCR-PTB	2865625	1
Power and error message module, spring-cage terminal blocks	MACX MCR-PTB-SP	2924184	1

4 Technical data

Input data	
Description of the input	Intrinsically safe
Current input signal	4 mA ... 20 mA
Transmitter supply voltage	> 16 V (at 20 mA)
Underload/overload signal range	0 mA ... 24 mA
Output	
Output description	Current output
Current output signal	4 mA ... 20 mA (active)
Transmission Behavior	1:1 to input signal
Load/output load current output	≤ 450 Ω (20 mA) ≤ 375 Ω (24 mA)
Output behavior in the event of an error	< 3.6 mA (In the event of cable break at the input (as per NE 43)) > 22.5 mA (In the event of cable short circuit at the input (as per NE 43))
Underload/overload signal range	0 mA ... 24 mA
Supply	
Nominal supply voltage	24 V DC
Supply voltage range	19.2 V DC ... 30 V DC (24 V DC (-20% ... +25%))
Max. current consumption	< 100 mA (24 V / 20 mA)
Power loss	< 1.4 W (at 24 V DC / 20 mA)
General data	
HART function	Yes
Protocols supported	HART
Signal bandwidth	as per HART specifications
Transmission error, typical	< 0.05 % (of final value)
Maximum transmission error	< 0.1 % (of final value)
Maximum temperature coefficient	< 0.01 %/K
Step response (10-90%)	< 1.3 ms (for 4 mA ... 20 mA step)
Degree of protection	IP20
Inflammability class according to UL 94	V0

General data [...]

Surge voltage category	II
Pollution degree	2
Diameter Test socket	2.3 mm
Status display	Green LED (supply voltage)
Dimensions W / H / D	12.5 mm / 99 mm / 114.5 mm
Type of housing	PA 66-FR green

Connection data**Screw connection****Spring-cage connection**

Conductor cross section, solid	0.2 mm ² ... 2.5 mm ²	0.2 mm ² ... 1.5 mm ²
Conductor cross section, stranded	0.2 mm ² ... 2.5 mm ²	0.2 mm ² ... 1.5 mm ²
Conductor cross section AWG/kcmil	24 ... 14	24 ... 16
Stripping length	7 mm	8 mm
Tightening torque	0.5 Nm ... 0.6 Nm	

Ambient conditions

Ambient temperature (operation)	-20 °C ... 60 °C (Any mounting position)
Ambient temperature (storage/transport)	-40 °C ... 80 °C
Permissible humidity (operation)	10 % ... 95 % (non-condensing)
Maximum altitude for use above sea level	≤ 2000 m

Electrical isolation

Input/output, power supply	
Rated insulation voltage (surge voltage category II; pollution degree 2, safe isolation as per EN 61010-1)	300 V _{rms}
50 Hz, 1 min., test voltage	2.5 kV
Input/output	
Peak value in accordance with EN 60079-11	375 V
Input/power supply	
Peak value in accordance with EN 60079-11	375 V
Output 1/output 2/ power supply	
50 Hz, 1 min., test voltage	1.5 kV

Safety data as per ATEX



Max. output voltage U _o	25.2 V
Max. output current I _o	93 mA
Max. output power P _o	587 mW
Group (Max. external inductivity L _o / Max. external capacitance C _o)	IIB : 4 mH / 820 nF IIC : 2 mH / 107 nF
Safety-related maximum voltage U _m	253 V AC (125 V DC)

Conformance with EMC Directive 2004/108/EC

Noise immunity according to EN 61000-6-2
When being exposed to interference, there may be minimal deviations.

Noise emission according to EN 61000-6-4

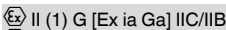
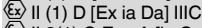
Conformance / approvals

Conformance	CE-compliant, additionally EN 61326
ATEX (BVS 13 ATEX E 001 X)	  
IECEX (IECEX BVS 13.0007X)	[Ex ia Ga] IIC/IIB [Ex ia Da] IIIC Ex nA [ia Ga] IIC T4 Gc
Functional safety (SIL)	SIL 3

5 Safety regulations and installation notes

5.1 Installation notes

- The device is a piece of equipment (category 1) which belongs to the "Intrinsic Safety" ignition protection class and can be installed in Ex zone 2 as a category 3 device. It meets the requirements of EN 60079-0:2012, EN 60079-11:2012, EN 60079-15:2010, IEC 60079-0 ed. 6.0, IEC 60079-11 ed. 6.0, and IEC 60079-15 ed. 4.0.
- Installation, operation, and maintenance may only be carried out by qualified electricians. Follow the installation instructions as described. When installing and operating the device, the applicable regulations and safety directives (including national safety directives), as well as general technical regulations, must be observed. For the safety technology data, see this packing slip and the certificates (EC examination certificate and other approvals if appropriate).
- The device must not be opened or modified. Do not repair the device yourself, replace it with an equivalent device. Repairs may only be carried out by the manufacturer. The manufacturer is not liable for damage resulting from violation.
- The IP20 protection (IEC 60529/EN 60529) of the device is intended for use in a clean and dry environment. The device must not be subject to mechanical strain and/or thermal loads, which exceed the limits described.
- The device complies with the EMC regulations for industrial areas (EMC class A). When using the device in residential areas, it may cause radio interference.

5.2 Intrinsic safety

- The device is approved for intrinsically safe (Ex-i) circuits up to Ex zone 0 (gas) and Ex zone 20 (dust). The safety technology values for intrinsically safe equipment and the connecting lines must be observed for the hook-up process (IEC/EC 60079-14) and the values specified in this installation note and/or the EC examination certificate must be observed.
- When carrying out measurements on the intrinsically safe side, observe the relevant regulations regarding the connection of intrinsically safe equipment. Use only these approved measuring devices in intrinsically safe circuits.
- If the device was used in circuits which are not intrinsically safe, it is forbidden to use it again in intrinsically safe circuits. Label the device clearly as being not intrinsically safe.

5.3 Installation in Zone 2

- Observe the specified conditions for use in potentially explosive areas! Install the device in a suitable approved housing with a minimum of IP54 protection) that meets the requirements of EN 60079-15. Observe the requirements of EN 60079-14.
- In potentially explosive areas, terminals may only be snapped onto or off the DIN rail connector and wires may only be connected or disconnected when the power is switched off.
- The device must be stopped and immediately removed from the Ex area if it is damaged, was subject to an impermissible load, stored incorrectly or if it malfunctions.

5.4 Safety-related applications (SIL)

When using the device in safety-related applications, observe the instructions in "Safety-related applications", as the requirements differ for safety-related functions.

6 Installation



NOTE: Electrostatic discharge
 The device contains components that can be damaged or destroyed by electrostatic discharge. When handling the device, observe the necessary safety precautions against electrostatic discharge (ESD) according to EN 61340-5-1 and IEC 61340-5-1.

6.1 Structure



Bild 1 Structure

- 1 Plug-in COMBICON screw or spring-cage terminal block with integrated test socket
- 2 Green "PWR" LED, power supply
- 3 Snap-on foot for DIN rail mounting
- 4 Connection option for DIN rail connector

6.2 Basic circuit diagram with connection terminal blocks

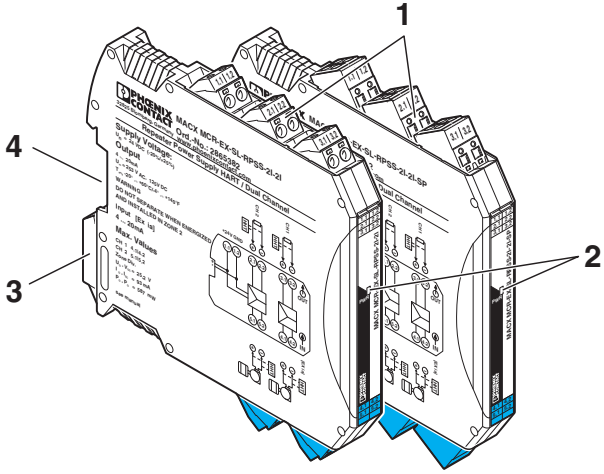

Bild 2 Basic circuit diagram

Input (intrinsically safe)

- Channel 1: connection of 2-wire transmitters or 2-wire measuring transducers at terminals 4.1 (+) and 4.2 (-)
- Channel 2: connection of 2-wire transmitters or 2-wire measuring transducers at terminals 5.1 (+) and 5.2 (-)

HART communicators (HHT) can be connected as shown in the basic circuit diagram. Test sockets (diameter 2.3 mm) have been integrated for this purpose.

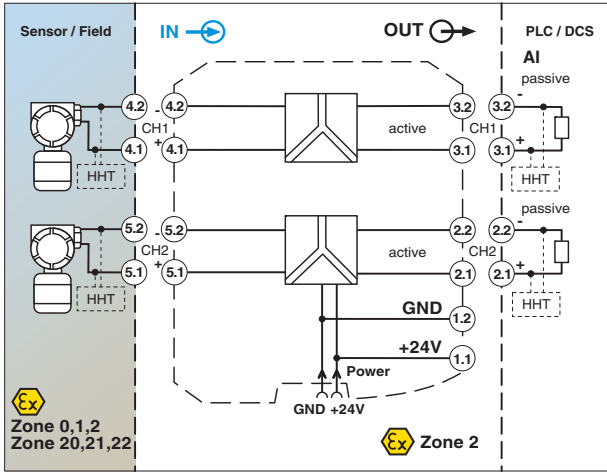

Always adhere to the safety regulations (1.2. Intrinsic safety).

Output

- Channel 1: active output (terminals 3.1 (+) and 3.2 (-)) for connecting passive analog input cards
- Channel 2: active output (terminals 2.1 (+) and 2.2 (-)) for connecting passive analog input cards

HART communicators (HHT) can be connected as shown in the basic circuit diagram. Test sockets (diameter 2.3 mm) have been integrated for this purpose.

6.3 Dimensions



Bild 3 Dimensions



6.4 Assembly

**WARNING: Explosion hazard**

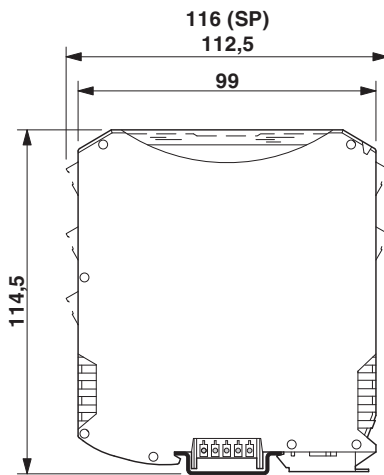
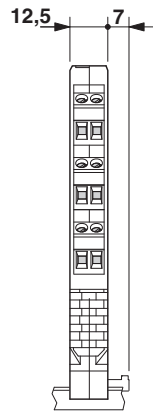
If the device has been used in non-intrinsically safe circuits, it must not be used again in intrinsically safe circuits.

The device must be clearly marked as non-intrinsically safe.



EN / UL 61010-1:

- Provide for a switch/circuit-breaker in the vicinity of a device that is marked as disconnect device for this device.
- Provide overcurrent protection ($I \leq 16 \text{ A}$) within the installation.
- To protect the device against mechanical or electrical damage, install it in a suitable housing with appropriate degree of protection as per IEC 60529.
- During maintenance work, disconnect the device from all effective power sources.
- If the device is not used as described in the documentation, the intended protection can be negatively affected.
- Thanks to its housing, the device has basic insulation to the neighboring devices, for 300 Veff. If several devices are installed next to each other, this has to be taken into account, and additional insulation has to be installed if necessary! If the neighboring device is equipped with basic insulation, no additional insulation is necessary.
- The voltages present at the input, output, and supply are extra-low voltages (ELV). Depending on the application, hazardous voltage ($> 30 \text{ V}$) to ground may occur. Safe electrical isolation between inputs and outputs and between the inputs and the supply exists for such cases.



Bild 4 Mounting and removing

- Mount the device on a 35 mm DIN rail according to DIN EN 60715.
- When using the DIN rail connector, first insert it in the 35 mm DIN rail according to EN 60715 (A - C). DIN rails with a height of 7.5 mm or more can be used. The DIN rail connector is used to bridge the power supply and communication.
- The snap-in direction of the device and DIN rail connector must be observed: snap-on foot on the bottom and plug on the left.
- Install the module in a suitable housing to meet the requirements for the protection class.
- Before startup, check that the device is operating and wired correctly, in particular with regard to the wiring and marking of the intrinsically safe circuits.

6.5 Connecting the cables

- Screw terminal blocks: fit the litz wires with ferrules, permitted conductor cross section: 0.2 mm² to 2.5 mm²
- Spring-cage terminal blocks: fit the litz wires with ferrules, permitted conductor cross section: 0.2 mm² to 1.5 mm²
- Install intrinsically safe and non-intrinsically safe cables separately

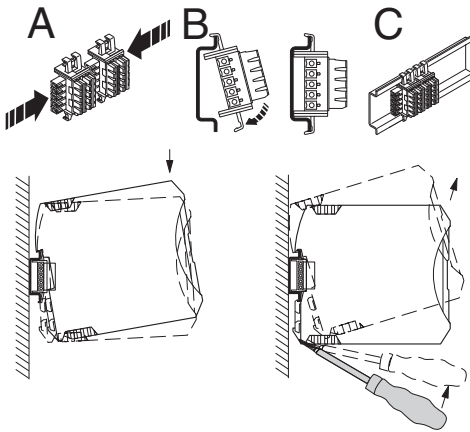
Screw Connection



Bild 5 Screw connection

- Insert the wire into the corresponding connection terminal block.
- Use a screwdriver to tighten the screw in the opening above the connection terminal block. Tightening torque: 0.6 Nm

Spring-cage connection:

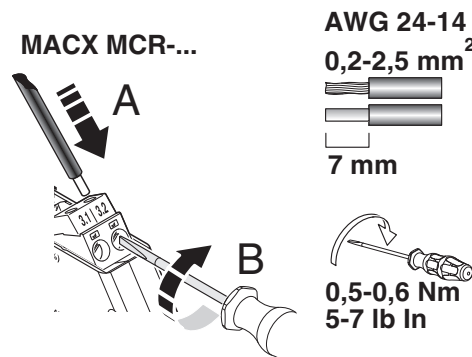

Bild 6 Spring-cage connection

- Insert the wire into the corresponding connection terminal block.

6.6 Power supply

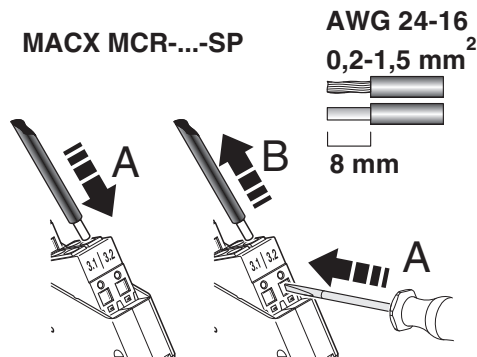

NOTE

Never connect the supply voltage directly to the DIN rail connector. It is not permitted to draw power from the DIN rail connector or from individual modules.

The supply voltage can be supplied via terminal points 1.1 and 1.2 or via the DIN rail connector.

Supply via the MACX Analog Ex module

Where the total current consumption of the aligned modules does not exceed 400 mA, the power can be supplied directly at the connection terminal blocks of the module.

Up to 16 modules can be supplied depending on the current consumption of the modules.

We recommend connecting a 630 mA fuse (normal-blow or slow-blow) upstream.

Supply via power and error message module

The MACX MCR-PTB (Order No. 2865625) or the MACX MCR-PTB-SP (Order No. 2924184) supply and error message module is used to provide the supply voltage to the DIN rail connector.

Simple or redundant diode-decoupled power supply is possible.

Depending on the current consumption of the modules, up to 150 individual modules can be supplied by a supply that is protected by a fuse.

The module has integrated error evaluation. An auxiliary supply failure or fuse fault is indicated at a relay contact and displayed via a flashing LED.

7 Comparison of the safety data



WARNING: Explosion hazard

Compare the safety data before connecting a device located in the Ex i area to this device.

Provide proof of intrinsic safety according to standard IEC/EN 60079-14 and other national standards and installation specifications, if applicable.

Safety data

Field devices	U_i, I_i, P_i, L_i, C_i
Ex repeater power supply	U_o, I_o, P_o, L_o, C_o

The values for U_o, I_o, P_o, L_o, C_o can be found under "Safety data according to ATEX" in the "Technical data" section.

Example for proof of intrinsic safety (simple circuit)

$$U_i \geq U_o$$

$$I_i \geq I_o$$

$$P_i \geq P_o$$

$$L_i + L_c \leq L_o$$

$$C_i + C_c \leq C_o$$

L_c and C_c depend on the cables used.

Condition $L_i \leq 1\%$ of L_o or $C_i \leq 1\%$ of C_o

8 Safety-related applications

8.1 Safety characteristic data

The following notes apply for the devices:

Designation	Order No.
MACX MCR-EX-SL-RPSS-2I-2I	2865382
MACX MCR-EX-SL-RPSS-2I-2I-SP	2924676

Single-channel version

In the case of the single-channel version, each of the two channels can be used for a (different) safety function.

The following then applies for the safety function:

- Type A device (according to EN 61508-2)
- Safety integrity level (SIL) 2 and 3
- HFT 0
- MTTR 24 h
- Ambient temperature 40°C

The safety function of the device involves the electrically isolated forwarding of a 4 ... 20 mA standard signal with a maximum deviation of 2%.

The range from 3.6 ... 21 mA is considered the valid signal range.

Output values outside this range are considered as the safe state, which is detected by the subsequent controller.

Safe failures in the device are therefore those errors where the device sends an output signal that deviates from the input signal by no more than 2%.

Dangerous failures are errors where the device does not follow a change in the input signal or deviates from the input signal by more than 2% and is not outside the range.

Errors that can be detected as dangerous failures are those which send a signal outside the standard range (< 3.6 mA and > 21 mA).

The failure rates in FIT for each of the channels are as follows:

λ_{SU}	λ_{SD}	λ_{DU}	λ_{DD}	SFF	DC _D
316	0	55	345	92.27%	86.25%

PFD_{avg} values

T [PROOF]	1 year	4 years	5 years
PFD _{avg}	2.52 10 ⁻⁴	9.79 10 ⁻⁴	1.22 10 ⁻³

$$PFH = 5.53 \cdot 10^{-8}/h$$

The device is therefore suitable for SIL 3 applications.

In SIL 2 applications, if the percentage of the device for the entire safety chain is assumed to be a maximum of 10%, a maintenance/test interval of 4 years can be achieved.

Sensor	Device	Processing	Actuator
25 %	< 10 %	15 %	50 %

The maintenance/test interval depends on the characteristic data of all devices involved in the safety chain. The intervals may be shorter or longer depending on this characteristic data.

In SIL 3 applications, it is recommended that the maximum possible test interval is determined together with data from the other devices involved in the safety chain.

Two-channel version

With the two-channel version, both channels of the repeater power supply are used for safety-related applications, which means that two different sensors are present at the measurement location and signal conditioning for the standard signal is 2-channel. For this, you must connect suitable measuring transducers and sensors to the inputs of the 2-channel repeater power supply. The subsequent safety-related controller then compares both signals to check that they match.

The following then applies for the safety function:

- Type A device (according to EN 61508-2)
- Safety integrity level (SIL) 3
- HFT 1
- MTTR 24 h
- Ambient temperature 40°C

The safety functions of the device involve the electrically isolated forwarding of 4 ... 20 mA standard signals with a maximum deviation of 2%.

The range from 3.6 ... 21 mA is considered the valid signal range.

Output values outside this range are considered as the safe state, which is detected by the subsequent controller.

Safe failures in the device are therefore errors where the device sends output signals that deviate from the relevant input signals by no more than 2%.

Dangerous failures are errors where the device does not follow a change in the input signal or deviates from the input signal by more than 2% and is not outside the range.

Errors that can be detected as dangerous failures are those which send a signal outside the standard range (< 3.6 mA and > 21 mA).

The failure rates in FIT for the entire device are as follows:

λ_{SU}	λ_{SD}	λ_{DU}	λ_{DD}	SFF	DC _D
549	0	92	567	92.36%	86.04%

PFD_{avg} values

T [PROOF]	1 year	5 years	10 years
PFD _{avg}	0.91 10 ⁻⁴	4.15 10 ⁻⁴	8.27 10 ⁻⁴

$$PFH = 1.99 * 10^{-8}/h$$

When calculating the average probability of a dangerous failure on demand, errors with the same cause were taken into consideration and a β or β_D factor of 2% was determined.

The device is therefore suitable for SIL 3 applications.

In SIL 2 applications, if the percentage of the device for the entire safety chain is assumed to be a maximum of 10%, a maintenance/test interval of 10 years can be achieved.

Sensor	Device	Processing	Actuator
25 %	< 10 %	15 %	50 %

The maintenance/test interval depends on the characteristic data of all devices involved in the safety chain. The intervals may be shorter or longer depending on this characteristic data.

In SIL 3 applications, it is recommended that the maximum possible test interval is determined together with data from the other devices involved in the safety chain.

8.2 Conditions

- The failure rates of the components used remain constant throughout the period of use.
- The propagation of errors by the device in the system is not taken into consideration.
- The failure rates of the external power supply are not taken into consideration.
- The specified error rates are based on an ambient temperature of +40°C. For an ambient temperature of +60°C, the error rates must be multiplied by factor 2.5. Factor 2.5 is based on guide values.

8.3 Installation and startup

NOTE: Installation, operation, and maintenance may only be carried out by qualified specialist personnel.

During installation, observe the instructions in the package slip:

Designation	MNR No.
PACKB.MACX MCR-EX-SL-RPSS-2I-2I	9060873

The package slip is supplied with the device. It can also be downloaded at: phoenixcontact.net/products.

Lockable housing with IP54 protection is recommended for the installation of the devices.

- Connect the device according to the installation notes.
- Make sure that the connected sensor and measuring transducer correspond to the intended configuration.
- Check that the device operates correctly with the measuring transducer and sensor connected.
- A calibrated sensor simulator and a calibrated digital multimeter may be required in order to check the device with the measuring transducer connected.
- Start up the safety circuit and check that it operates correctly.

8.4 Notes on operation

In normal operation, only the green LED (PWR) is on.

If a failure occurs during operation, the output signal is usually set to a value outside the "normal" signal range of 3.6 ... 21 mA. The connected SIS should therefore check the validity of the read signal values and initiate appropriate measures in the event of deviations from the normal values.

You should also check whether the connected measuring transducer responds to line faults at the sensors. After being switched off and on again, the required voltages are established in the device. Signal transmission is then performed without further action.

8.5 Recurring checks

The function of the entire safety loop must be checked regularly according to EN 61508 and EN 61511.

The intervals for checking are specified by the intervals of each individual device within the safety loop.

It is the operator's responsibility to select the type of checks and the checking intervals in the specified time period.

In SIL 2 applications, the repeater power supplies/signal conditioners must be checked at least every 4 (10) years (maximum proof test interval, if they represent 10% of the entire safety chain).

Checking must be carried out in such a way that the correct function of the safety equipment in conjunction with all components can be verified.

Possible procedure for recurring checks for discovering dangerous and undetected device failures

A calibrated simulator (0/4 ... 20 mA current) or a sensor simulator and one or ideally two calibrated digital multimeters are required in order to check the devices.

1. Take appropriate steps to prevent incorrect use.
2. Disconnect the safety circuit from further processing.
3. Connect the current simulator to the input of the repeater power supply/signal conditioner, or the sensor simulator to the input of the measuring transducer.
4. Connect the digital multimeters to the input and output of the repeater power supply/signal conditioner.
5. At the input of the device, set a signal in the range from 4 ... 20 mA or at the input of the connected measuring transducer, set a suitable signal with the sensor simulator.
6. Measure the current in the repeater power supply/signal conditioner. The output must be set to the same value.
7. Setting ≤ 3.6 mA or > 22 mA verifies that the subsequent processing can detect signals that are out of range and evaluate them accordingly. If the output value deviates from the input value by more than 3 times the specified class accuracy rating, the device should be checked. In the event of an error, the device should be replaced with an equivalent device.
8. Restore the safety circuit to full functionality.
9. Resume normal operation.

8.6 Repair

The devices have a long service life, are protected against malfunctions, and are maintenance-free.

However, if a device should fail, send it back to Phoenix Contact immediately. The type of malfunction and possible cause must also be stated.

Please use the original packaging or other suitable safe packaging when sending devices back for repairs or recalibration.

Phoenix Contact GmbH & Co. KG
Abteilung Service und Reparatur
Flachmarktstr. 8
32825 Blomberg
GERMANY

8.7 Standards

The devices are developed and tested according to the following standards:

EN 61508: 2011	Functional safety of electrical/electronic/programmable electronic safety-related systems
EN 61326-1: 2006	Electrical equipment for measurement, control and laboratory use - EMC requirements
IEC 61326-3-2: 2006	Electrical equipment for measurement, control and laboratory use - EMC requirements - Part 3-2: Immunity requirements for safety-related systems and for equipment intended to perform safety-related functions (functional safety) - Industrial applications with specified electromagnetic environment

8.8 Abbreviations

Abbreviation		Meaning
DC _D	Diagnostic coverage of dangerous failures	Diagnostic coverage of dangerous failures: $DC_D = \lambda_{DD}/(\lambda_{DU} + \lambda_{DD})$
DC _S	Diagnostic coverage of safe failures	Diagnostic coverage of safe failures: $DC_S = \lambda_{SD}/(\lambda_{SU} + \lambda_{SD})$
FIT	Failure in time	1 FIT = 1 failure/10 ⁹ h
HFT	Hardware fault tolerance	Hardware fault tolerance: ability of a function unit to continue with the execution of a demanded function despite existing faults or deviations
β	Common cause factor	Proportion of undetected failures as a result of a common cause
β_D	Common cause factor, diagnostic	Proportion of failures as a result of a common cause which are detected by the diagnostic test.
λ_D	Rate of dangerous failures	Proportion of dangerous failures per hour
λ_{DD}	Rate of dangerous detected failures	Proportion of detected dangerous failures per hour
λ_{DU}	Rate of dangerous undetected failures	Proportion of undetected dangerous failures per hour
λ_S	Rate of safe failures	Proportion of safe failures per hour
λ_{SD}	Rate of safe detectable failures	Proportion of detectable safe failures per hour
λ_{SU}	Rate of safe undetectable failures	Proportion of undetectable safe failures per hour
MTBF	Mean time between failures	Mean time between consecutive failures
PFD _{avg}	Average probability of failure on demand	Average probability of dangerous failure on demand of a safety function
PFH	Probability of a dangerous failure per hour	Probability of failure per hour for the safety function
SFF	Safe failure fraction	Proportion of safe failures: proportion of failures without the potential to set the safety-related system to a dangerous or impermissible function state
SIL	Safety integrity level	International standard IEC 61508 defines four discrete safety integrity levels (SIL 1 to 4). Each level corresponds to a probability range for the failure of a safety function. The higher the safety integrity level of safety-related systems, the lower the probability that the demanded safety functions will not be performed.

Компания «Life Electronics» занимается поставками электронных компонентов импортного и отечественного производства от производителей и со складов крупных дистрибьюторов Европы, Америки и Азии.

С конца 2013 года компания активно расширяет линейку поставок компонентов по направлению коаксиальный кабель, кварцевые генераторы и конденсаторы (керамические, пленочные, электролитические), за счёт заключения дистрибьюторских договоров

Мы предлагаем:

- Конкурентоспособные цены и скидки постоянным клиентам.
- Специальные условия для постоянных клиентов.
- Подбор аналогов.
- Поставку компонентов в любых объемах, удовлетворяющих вашим потребностям.
- Приемлемые сроки поставки, возможна ускоренная поставка.
- Доставку товара в любую точку России и стран СНГ.
- Комплексную поставку.
- Работу по проектам и поставку образцов.
- Формирование склада под заказчика.
- Сертификаты соответствия на поставляемую продукцию (по желанию клиента).
- Тестирование поставляемой продукции.
- Поставку компонентов, требующих военную и космическую приемку.
- Входной контроль качества.
- Наличие сертификата ISO.

В составе нашей компании организован Конструкторский отдел, призванный помогать разработчикам, и инженерам.

Конструкторский отдел помогает осуществить:

- Регистрацию проекта у производителя компонентов.
- Техническую поддержку проекта.
- Защиту от снятия компонента с производства.
- Оценку стоимости проекта по компонентам.
- Изготовление тестовой платы монтаж и пусконаладочные работы.



Тел: +7 (812) 336 43 04 (многоканальный)

Email: org@lifeelectronics.ru