

ISL97632IRTZ-EVALZ

Using the ISL97632IRTZ-EVALZ White LED Driver Demo Board

AN1496  
Rev 0.00  
November 4, 2009

Introduction

The ISL97632 is a white LED driver with digital dimming. The demo kit schematic is shown in Figure 1. It is made up of an ISL97632IRTZ-EVALZ evaluation board connected with a USB adapter board that can be programmed by a PC running Windows XP (Note 1).

Jumpers JP1 to JP5 can be optionally used to disable five of the seven LEDs. The ISL97632 is guaranteed to drive six LEDs (3.5V/30mA type). It is possible to drive seven LEDs at 20mA if the total VF is lower than the OVP threshold and the input voltage is at nominal rather than low level.

Jumper S1 is used to enable ISL97632 that must be connected with the center and right most pins.

Jumper S2 is used to connect the single wire digital input that must be connected with the center and the left most pins.

Jumper S3 is not used but must be connected with the center and bottom pins.

Jumper S4 is used to select either a 4.75Ω resistor R1 or a 100Ω potentiometer, R2. If R1 is used, connect S4 with the center and the left most pins. This resistance sets the LED supply current.

$$I_{LED} = (9.8 + 5.68 \cdot S) / R \tag{EQ. 1}$$

where S is the programming step from 0 to 31.

Steps for Setting up the Demo Board:

1. Unzip the ISL97632-v091.zip file (download from <http://www.intersil.com/ISL97632> or contact Intersil's Technical Support Center at (800) 550-7364.
2. Run setup.exe.
3. Select the numbers of LEDs used with proper jumpers.
4. Connect the USB to the PC.
5. Apply a DC voltage of 2.7V to 5.5V to V<sub>IN</sub>. The input voltage must be lower than the expected output voltage for the boost function. If only one or two LEDs are used and the input is higher than the output, the LED may light but it is not a valid operation for ISL97632.
6. Use R<sub>1</sub> or R<sub>2</sub> with proper jumpers to set the desirable LED peak current.
7. Open the ISL97632 program and adjust the LED current.

Sometimes Steps 4 through 7 may need to be repeated if the PC does not recognize the USB device when it is inserted.

NOTE:

1. Intersil cannot guarantee the software compatibility on all PCs running Windows XP.

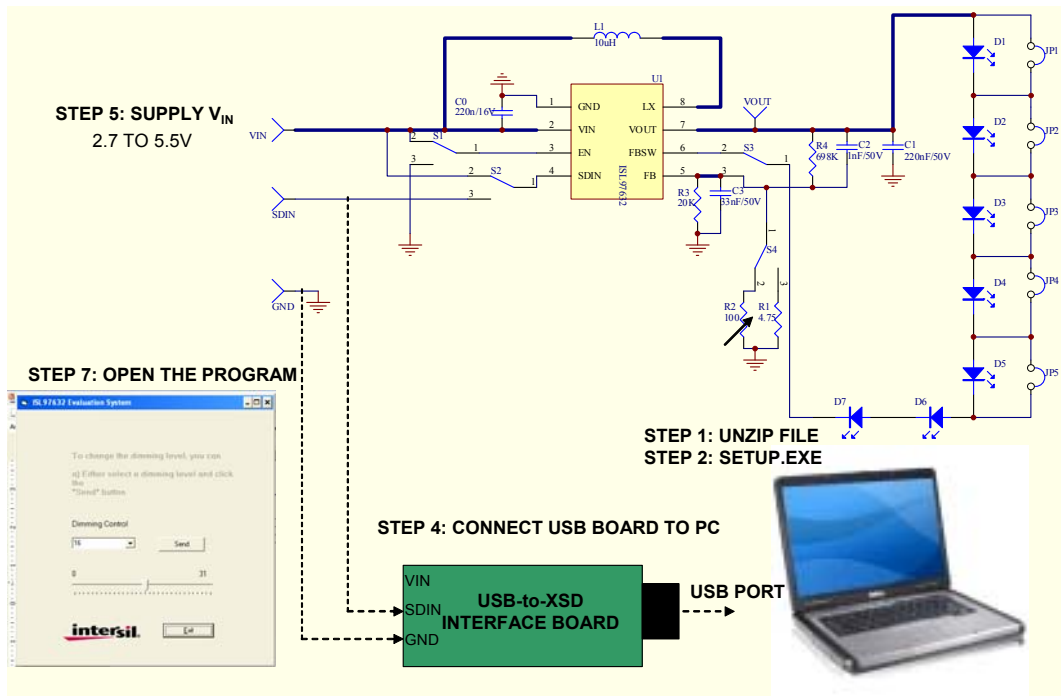

FIGURE 1. SCHEMATIC OF ISL97632IRTZ-EVALZ DEMO BOARD

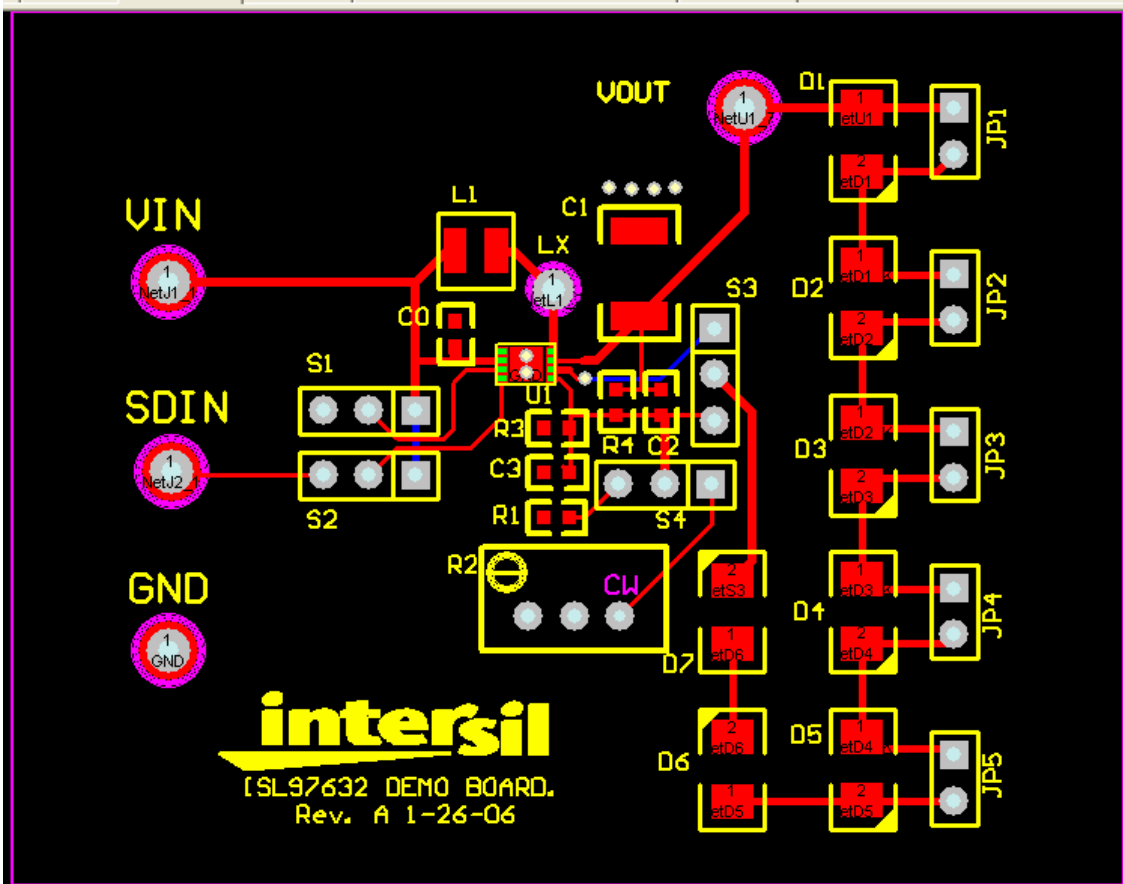

FIGURE 2. ISL97632IRTZ-EVALZ DEMO BOARD. RED TRACES ARE ON TOP LAYER AND BLUE TRACES ARE ON BOTTOM LAYER, RESPECTIVELY

TABLE 1. ISL97632IRTZ-EVALZ DEMO BOARD BOM

ITEM	QTY	REF	DESCRIPTION	VENDOR	PART NO.	PACKAGE
1	1	C2	1nF/50V			0603
2	1	R1	4.75			0603
3	1	L1	22 $\mu$ H	Coilcraft	1008PS-223KL	3.81mmx3.81mm
			10 $\mu$ H	Coilcraft	1008PS-103KL	3.81mmx3.81mm
4	1	R3	20k			0603
5	1	C3	33nF/50V			0603
6	1	R2	100			0603
7	1	C0	220n/16V			0603
8	1	C1	4.7 $\mu$ F/50V	Murata	GRM32ER71H475KA88	1210
9	1	R4	698k			0603
10	1	J3	GND			POWERPOST
11	1	U1	LED Driver	Intersil	ISL97632	TDFN2X3
12	1	JP3	JUMPER			JUMPER-2PIN
13	1	JP4	JUMPER			JUMPER-2PIN
14	1	JP5	JUMPER			JUMPER-2PIN
15	1	JP2	JUMPER			JUMPER-2PIN
16	1	JP1	JUMPER			JUMPER-2PIN
17	1	J2	SDIN			POWERPOST
18	1	J1	VIN			POWERPOST
19	1	J4	VOUT			POWERPOST
20	7	D1 to D7	LED	OSRAM	LW Y3SG	0.6mm MircoSIDLED
1	1	C2	1nF/50V			0603
2	1	R1	4.75			0603
3	1	L1	22 $\mu$ H	Coilcraft	1008PS-223KL	3.81mmx3.81mm

## Notice

1. Descriptions of circuits, software and other related information in this document are provided only to illustrate the operation of semiconductor products and application examples. You are fully responsible for the incorporation or any other use of the circuits, software, and information in the design of your product or system. Renesas Electronics disclaims any and all liability for any losses and damages incurred by you or third parties arising from the use of these circuits, software, or information.
2. Renesas Electronics hereby expressly disclaims any warranties against and liability for infringement or any other claims involving patents, copyrights, or other intellectual property rights of third parties, by or arising from the use of Renesas Electronics products or technical information described in this document, including but not limited to, the product data, drawings, charts, programs, algorithms, and application examples.
3. No license, express, implied or otherwise, is granted hereby under any patents, copyrights or other intellectual property rights of Renesas Electronics or others.
4. You shall not alter, modify, copy, or reverse engineer any Renesas Electronics product, whether in whole or in part. Renesas Electronics disclaims any and all liability for any losses or damages incurred by you or third parties arising from such alteration, modification, copying or reverse engineering.
5. Renesas Electronics products are classified according to the following two quality grades: "Standard" and "High Quality". The intended applications for each Renesas Electronics product depends on the product's quality grade, as indicated below.  
"Standard": Computers; office equipment; communications equipment; test and measurement equipment; audio and visual equipment; home electronic appliances; machine tools; personal electronic equipment; industrial robots; etc.  
"High Quality": Transportation equipment (automobiles, trains, ships, etc.); traffic control (traffic lights); large-scale communication equipment; key financial terminal systems; safety control equipment; etc.  
Unless expressly designated as a high reliability product or a product for harsh environments in a Renesas Electronics data sheet or other Renesas Electronics document, Renesas Electronics products are not intended or authorized for use in products or systems that may pose a direct threat to human life or bodily injury (artificial life support devices or systems; surgical implantations; etc.), or may cause serious property damage (space system; undersea repeaters; nuclear power control systems; aircraft control systems; key plant systems; military equipment; etc.). Renesas Electronics disclaims any and all liability for any damages or losses incurred by you or any third parties arising from the use of any Renesas Electronics product that is inconsistent with any Renesas Electronics data sheet, user's manual or other Renesas Electronics document.
6. When using Renesas Electronics products, refer to the latest product information (data sheets, user's manuals, application notes, "General Notes for Handling and Using Semiconductor Devices" in the reliability handbook, etc.), and ensure that usage conditions are within the ranges specified by Renesas Electronics with respect to maximum ratings, operating power supply voltage range, heat dissipation characteristics, installation, etc. Renesas Electronics disclaims any and all liability for any malfunctions, failure or accident arising out of the use of Renesas Electronics products outside of such specified ranges.
7. Although Renesas Electronics endeavors to improve the quality and reliability of Renesas Electronics products, semiconductor products have specific characteristics, such as the occurrence of failure at a certain rate and malfunctions under certain use conditions. Unless designated as a high reliability product or a product for harsh environments in a Renesas Electronics data sheet or other Renesas Electronics document, Renesas Electronics products are not subject to radiation resistance design. You are responsible for implementing safety measures to guard against the possibility of bodily injury, injury or damage caused by fire, and/or danger to the public in the event of a failure or malfunction of Renesas Electronics products, such as safety design for hardware and software, including but not limited to redundancy, fire control and malfunction prevention, appropriate treatment for aging degradation or any other appropriate measures. Because the evaluation of microcomputer software alone is very difficult and impractical, you are responsible for evaluating the safety of the final products or systems manufactured by you.
8. Please contact a Renesas Electronics sales office for details as to environmental matters such as the environmental compatibility of each Renesas Electronics product. You are responsible for carefully and sufficiently investigating applicable laws and regulations that regulate the inclusion or use of controlled substances, including without limitation, the EU RoHS Directive, and using Renesas Electronics products in compliance with all these applicable laws and regulations. Renesas Electronics disclaims any and all liability for damages or losses occurring as a result of your noncompliance with applicable laws and regulations.
9. Renesas Electronics products and technologies shall not be used for or incorporated into any products or systems whose manufacture, use, or sale is prohibited under any applicable domestic or foreign laws or regulations. You shall comply with any applicable export control laws and regulations promulgated and administered by the governments of any countries asserting jurisdiction over the parties or transactions.
10. It is the responsibility of the buyer or distributor of Renesas Electronics products, or any other party who distributes, disposes of, or otherwise sells or transfers the product to a third party, to notify such third party in advance of the contents and conditions set forth in this document.
11. This document shall not be reprinted, reproduced or duplicated in any form, in whole or in part, without prior written consent of Renesas Electronics.
12. Please contact a Renesas Electronics sales office if you have any questions regarding the information contained in this document or Renesas Electronics products.  
(Note 1) "Renesas Electronics" as used in this document means Renesas Electronics Corporation and also includes its directly or indirectly controlled subsidiaries.  
(Note 2) "Renesas Electronics product(s)" means any product developed or manufactured by or for Renesas Electronics.

(Rev.4.0-1 November 2017)



### SALES OFFICES

Renesas Electronics Corporation

<http://www.renesas.com>

Refer to "<http://www.renesas.com/>" for the latest and detailed information.

**Renesas Electronics America Inc.**  
1001 Murphy Ranch Road, Milpitas, CA 95035, U.S.A.  
Tel: +1-408-432-8888, Fax: +1-408-434-5351

**Renesas Electronics Canada Limited**  
9251 Yonge Street, Suite 8309 Richmond Hill, Ontario Canada L4C 9T3  
Tel: +1-905-237-2004

**Renesas Electronics Europe Limited**  
Dukes Meadow, Millboard Road, Bourne End, Buckinghamshire, SL8 5FH, U.K  
Tel: +44-1628-651-700, Fax: +44-1628-651-804

**Renesas Electronics Europe GmbH**  
Arcadiastrasse 10, 40472 Düsseldorf, Germany  
Tel: +49-211-6503-0, Fax: +49-211-6503-1327

**Renesas Electronics (China) Co., Ltd.**  
Room 1709 Quantum Plaza, No.27 ZhichunLu, Haidian District, Beijing, 100191 P. R. China  
Tel: +86-10-8235-1155, Fax: +86-10-8235-7679

**Renesas Electronics (Shanghai) Co., Ltd.**  
Unit 301, Tower A, Central Towers, 555 Langao Road, Putuo District, Shanghai, 200333 P. R. China  
Tel: +86-21-2226-0888, Fax: +86-21-2226-0999

**Renesas Electronics Hong Kong Limited**  
Unit 1601-1611, 16/F., Tower 2, Grand Century Place, 193 Prince Edward Road West, Mongkok, Kowloon, Hong Kong  
Tel: +852-2265-6688, Fax: +852-2886-9022

**Renesas Electronics Taiwan Co., Ltd.**  
13F, No. 363, Fu Shing North Road, Taipei 10543, Taiwan  
Tel: +886-2-8175-9600, Fax: +886-2-8175-9670

**Renesas Electronics Singapore Pte. Ltd.**  
80 Bendemeer Road, Unit #06-02 Hyflux Innovation Centre, Singapore 339949  
Tel: +65-6213-0200, Fax: +65-6213-0300

**Renesas Electronics Malaysia Sdn.Bhd.**  
Unit 1207, Block B, Menara Amcorp, Amcorp Trade Centre, No. 18, Jln Persiaran Barat, 46050 Petaling Jaya, Selangor Darul Ehsan, Malaysia  
Tel: +60-3-7955-9390, Fax: +60-3-7955-9510

**Renesas Electronics India Pvt. Ltd.**  
No.777C, 100 Feet Road, HAL 2nd Stage, Indiranagar, Bangalore 560 038, India  
Tel: +91-80-67208700, Fax: +91-80-67208777

**Renesas Electronics Korea Co., Ltd.**  
17F, KAMCO Yangjae Tower, 262, Gangnam-daero, Gangnam-gu, Seoul, 06265 Korea  
Tel: +82-2-558-3737, Fax: +82-2-558-5338

Компания «Life Electronics» занимается поставками электронных компонентов импортного и отечественного производства от производителей и со складов крупных дистрибьюторов Европы, Америки и Азии.

С конца 2013 года компания активно расширяет линейку поставок компонентов по направлению коаксиальный кабель, кварцевые генераторы и конденсаторы (керамические, пленочные, электролитические), за счёт заключения дистрибьюторских договоров

Мы предлагаем:

- Конкурентоспособные цены и скидки постоянным клиентам.
- Специальные условия для постоянных клиентов.
- Подбор аналогов.
- Поставку компонентов в любых объемах, удовлетворяющих вашим потребностям.
- Приемлемые сроки поставки, возможна ускоренная поставка.
- Доставку товара в любую точку России и стран СНГ.
- Комплексную поставку.
- Работу по проектам и поставку образцов.
- Формирование склада под заказчика.
- Сертификаты соответствия на поставляемую продукцию (по желанию клиента).
- Тестирование поставляемой продукции.
- Поставку компонентов, требующих военную и космическую приемку.
- Входной контроль качества.
- Наличие сертификата ISO.

В составе нашей компании организован Конструкторский отдел, призванный помогать разработчикам, и инженерам.

Конструкторский отдел помогает осуществить:

- Регистрацию проекта у производителя компонентов.
- Техническую поддержку проекта.
- Защиту от снятия компонента с производства.
- Оценку стоимости проекта по компонентам.
- Изготовление тестовой платы монтаж и пусконаладочные работы.



Тел: +7 (812) 336 43 04 (многоканальный)  
Email: [org@lifeelectronics.ru](mailto:org@lifeelectronics.ru)