

SMT Gate Drive Transformers

>1500VDC Basic and Functional Insulation

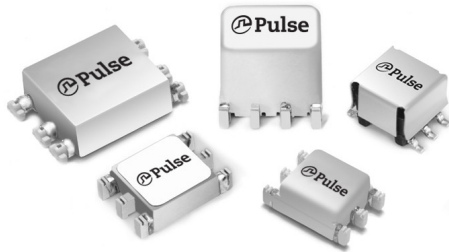

- Ⓢ >1500V_{DC} isolation (380V_{rms} continuous)
- Ⓢ Basic insulation (1.4mm creepage/clearance) and functional available
- Ⓢ Operating frequency: 50kHz and up

Electrical Specifications @ 25°C - Operating Temperature -40°C to +130°C⁵

Part Number ^{3,4}	Turns Ratio	Pri-Sec Isolation	MAX ¹ V* μ sec	Primary Inductance (μ H MIN)	Leakage ² Inductance (μ H MAX)	DCR Primary (Ω MAX)	DCR Secondary (Ω MAX)	Package Size (L x W x H) (mm MAX)
Functional Insulation								
PE-68386NL	1:1	1500 Vdc	9.7	785	0.46	0.60	0.60	8.6 x 6.7 x 2.5
P0926NL	1:1:1	1500 Vdc	23.8	300	0.50	2.00	2.00	8.0 x 6.6 x 5.3
✓ P0544NL	1:1:1	1500 Vdc	45.1	3300	0.80	1.25	1.25	9.0 x 8.6 x 7.6
✓ PA0264NL	1:1:1	1000 Vrms	12.7	1140	0.65	0.75	0.75	8.6 x 6.7 x 3.6
PA1323NL	1:1	1500 Vrms	21.7	600	2.0	1.25	1.25	9.5 x 7.1 x 5.3
Basic Insulation (1.4mm creepage and clearance between Primary and Secondary)								
PA0173NL	1:1:1	1500 Vrms	17.2	980	0.75	0.62	0.88	11.8 x 8.8 x 4.0
PA0185NL	1:1	1500 Vrms	17.2	980	0.75	0.88	0.62	11.8 x 8.8 x 4.0
PA0184NL	1:1	1500 Vrms	27.2	1200	0.50	0.91	0.91	9.0 x 8.6 x 7.6
PA0297NL	2:1:1	1500 Vrms	27.2	1200	0.60	0.91	0.46	9.0 x 8.6 x 7.6
PA2777NL	1:1	1500 Vrms	9.3	335.2	0.36	0.70	0.70	7.1 x 6.1 x 5.5
PA0510NL	2.5:1:1	1500 Vrms	27.2	1200	0.68	0.91	0.380	9.0 x 8.6 x 7.6
PA3493NL	1.25:1	1650 Vrms	23	656	1.3	1.03	0.85	10.9 x 9.7 x 2.7

Notes:

1. The Maximum volt- μ sec rating limits the peak flux density to 2200 Gauss when used in a unipolar drive application. For bi-polar drive applications, a maximum volt-sec of two times this rating is acceptable (ie: 2* (volt* μ sec rating) = (voltage applied to the primary) * dutycycle / Frequency = V * alpha / Freq_Hz = V * μ sec
2. Leakage inductance is measured at primary terminals with all secondaries shorted.
3. Optional Tape & Reel packaging can be ordered by adding a "T" suffix to the part number (i.e. P0544NL becomes P0544NLT). Pulse complies to industry standard tape and reel specification EIA481.
4. The "NL" suffix indicates an RoHS-compliant part number.
5. The temperature of the component (ambient plus temperature rise) must be within the stated operating temperature range.
6. Continuous isolation voltage confirmed by 125°C/1000hrs accelerated aging with the bias voltage applied between primary and secondary windings.

SMT Gate Drive Transformers

>1500VDC Basic and Functional Insulation

Mechanicals

Schematics

PE-68386NL

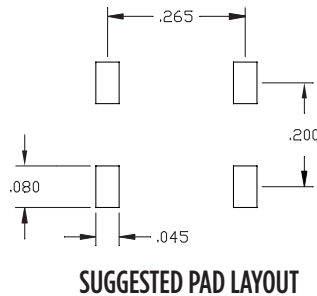

Weight0.28grams
 Tape & Reel1500/reel
 Tube60/tube
 Dimensions: $\frac{\text{Inches}}{\text{mm}}$
 Unless otherwise specified,
 all tolerances are: $\pm \frac{.010}{.25}$

Mechanicals

Schematics

PA0264NL

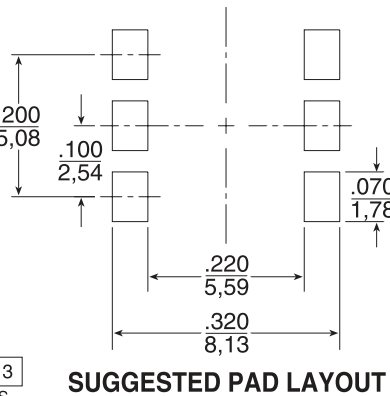
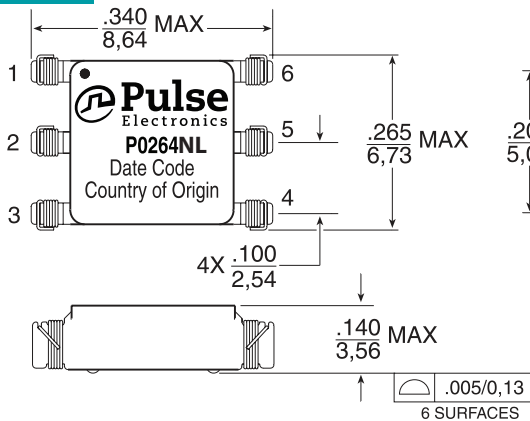

Weight0.28grams
 Tape & Reel1500/reel
 Tube60/tube
 Dimensions: $\frac{\text{Inches}}{\text{mm}}$
 Unless otherwise specified,
 all tolerances are: $\pm \frac{.010}{.25}$

Mechanicals

Schematics

P0926NL

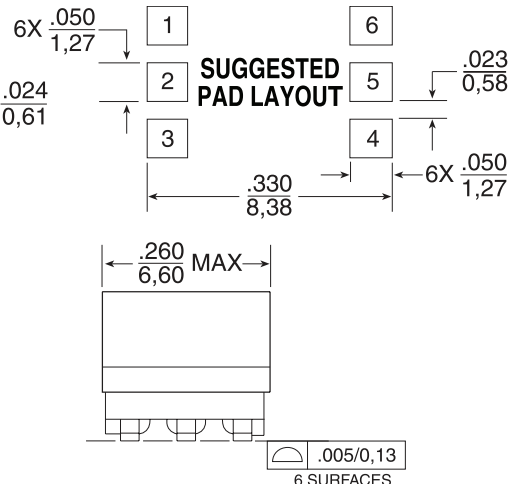
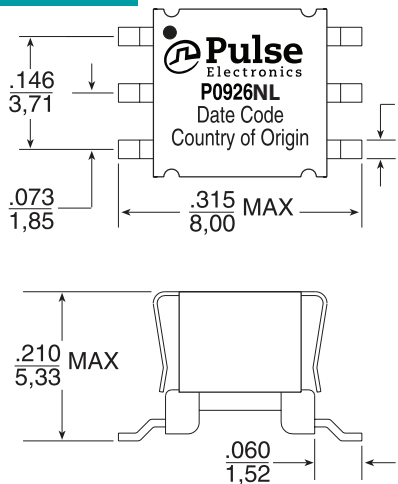

Weight0.48grams
 Tape & Reel1000/reel
 Tray120/tray
 Dimensions: $\frac{\text{Inches}}{\text{mm}}$
 Unless otherwise specified,
 all tolerances are: $\pm \frac{.010}{.25}$

SMT Gate Drive Transformers

>1500VDC Basic and Functional Insulation

Mechanicals (continued)

Schematics

PO544NL

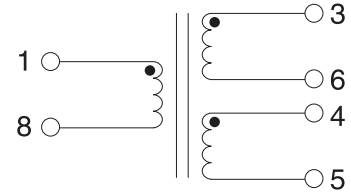
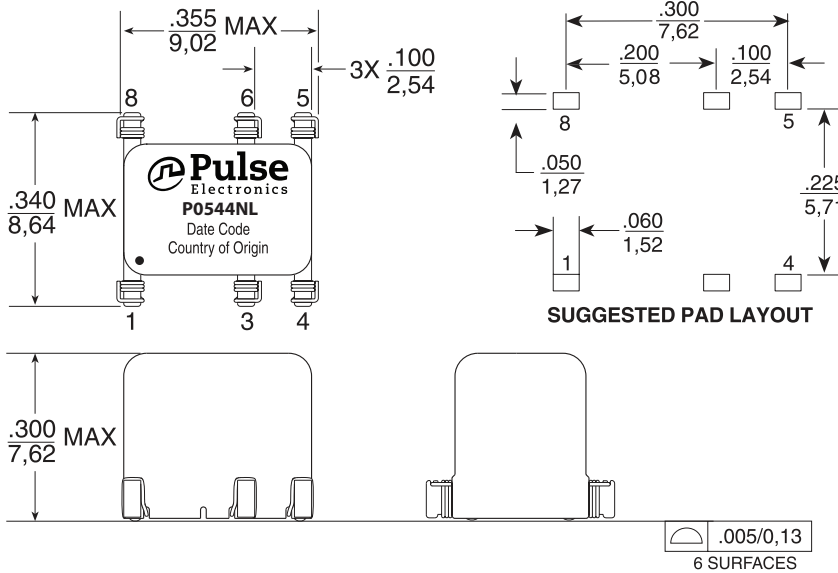

Weight0.60grams
 Tape & Reel400/reel
 Tube50/tube
 Dimensions: $\frac{\text{Inches}}{\text{mm}}$
 Unless otherwise specified,
 all tolerances are: $\pm \frac{.010}{0,25}$

Mechanicals

Schematics

PA0297NL, PA0510NL, PA0184NL

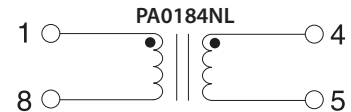
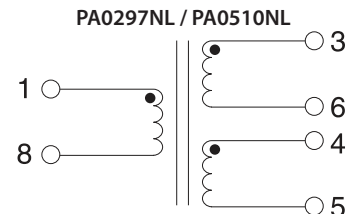
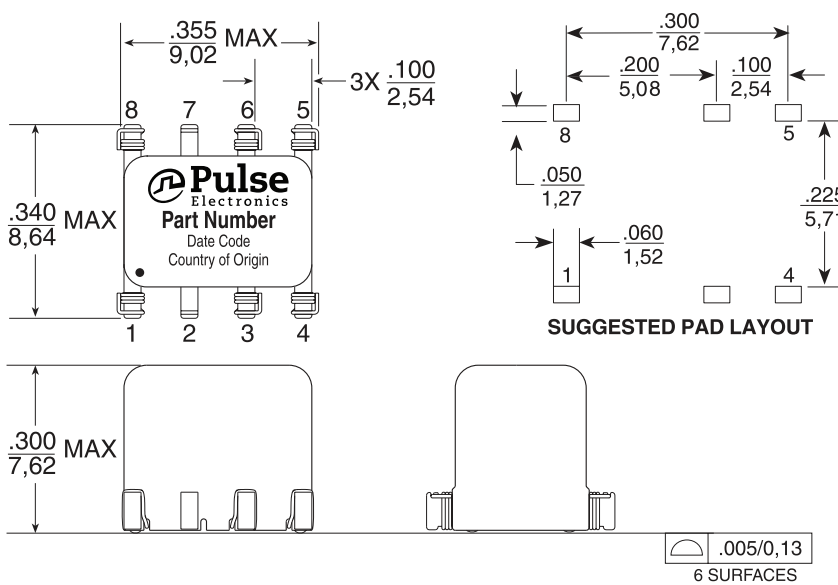

Weight0.60grams
 Tape & Reel400/reel
 Tube50/tube
 Dimensions: $\frac{\text{Inches}}{\text{mm}}$
 Unless otherwise specified,
 all tolerances are: $\pm \frac{.010}{0,25}$

* for PA0184 the pads for pins 3 and 6 in the suggested pad layout should not be used in the layout

SMT Gate Drive Transformers

>1500VDC Basic and Functional Insulation

Mechanicals (continued)

Schematics

PA0173NL, PA0185NL



Weight0.48grams
 Tape & Reel900/reel
 Tube60/tube
 Dimensions: $\frac{\text{Inches}}{\text{mm}}$
 Unless otherwise specified,
 all tolerances are: $\pm \frac{0.010}{0.25}$

Mechanicals

Schematics

PA3493NL

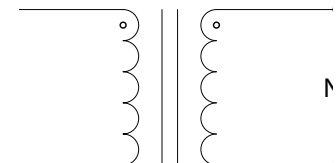
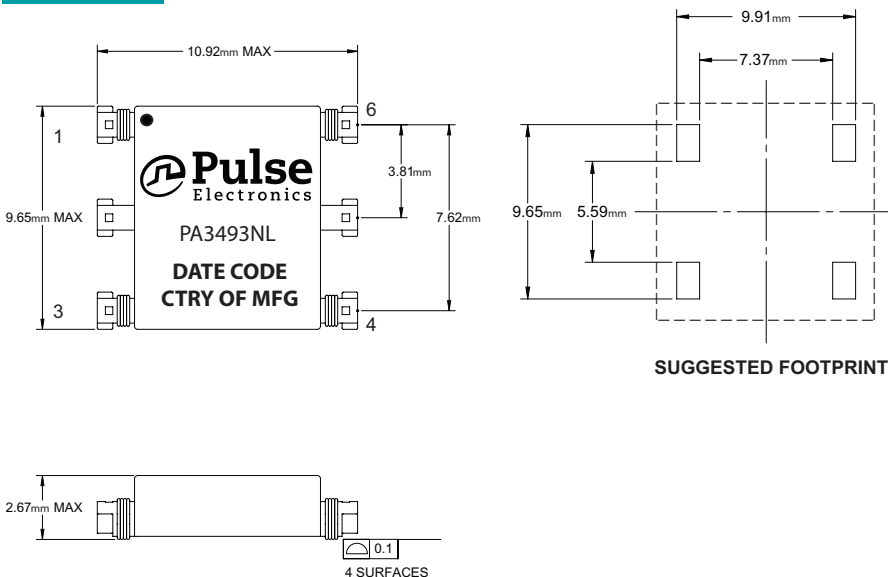

Weight0.31grams
 Tape & Reel1250/reel
 Tube50/tube
 Dimensions: mm
 Unless otherwise specified,
 all tolerances are: ± 0.25

SMT Gate Drive Transformers

>1500VDC Basic and Functional Insulation

Mechanicals (continued)

Schematics

PA2777NL

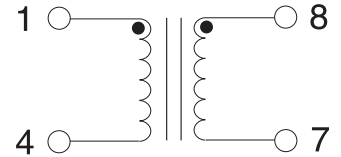
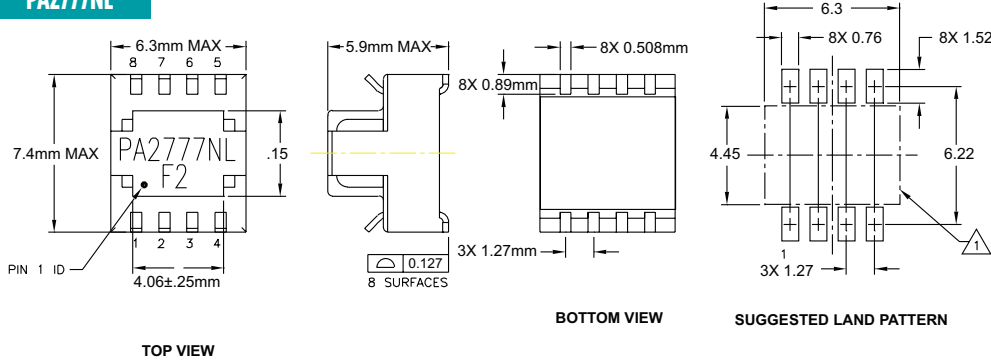

Weight0.32grams
Tape & Reel850/reel
Tube120/tube
Dimensions: mm
 Unless otherwise specified,
 all tolerances are: ±0.25

Mechanicals

Schematics

PA1323NL

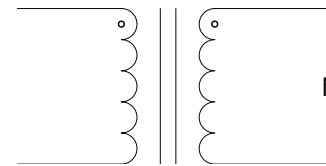
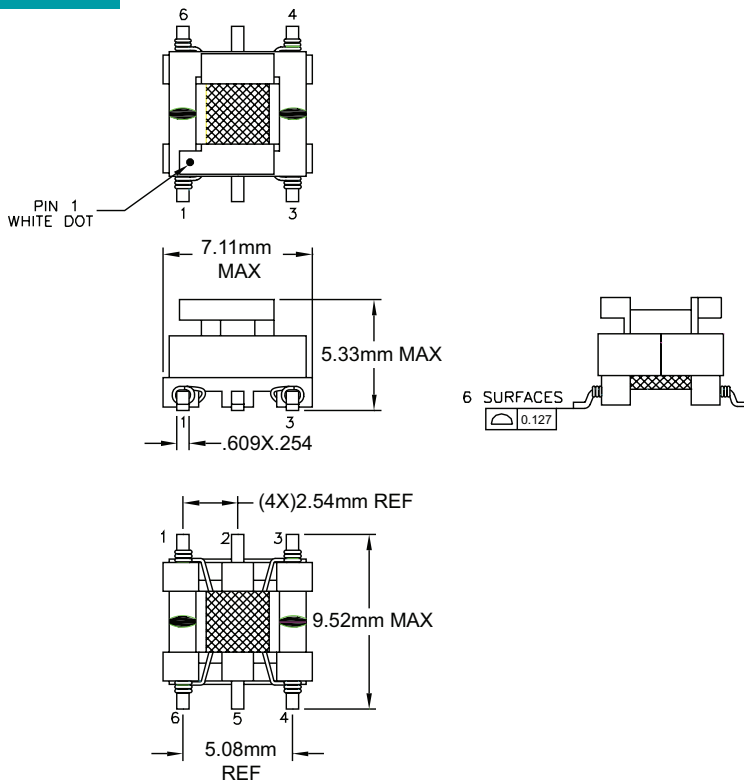

SUGGESTED PCB LAYOUT

Weight0.4grams
Tape & Reel700/reel
Tray225/tray
Dimensions: mm
 Unless otherwise specified,
 all tolerances are: ±0.25

SMT Gate Drive Transformers

>1500VDC Basic and Functional Insulation

TAPE & REEL INFO

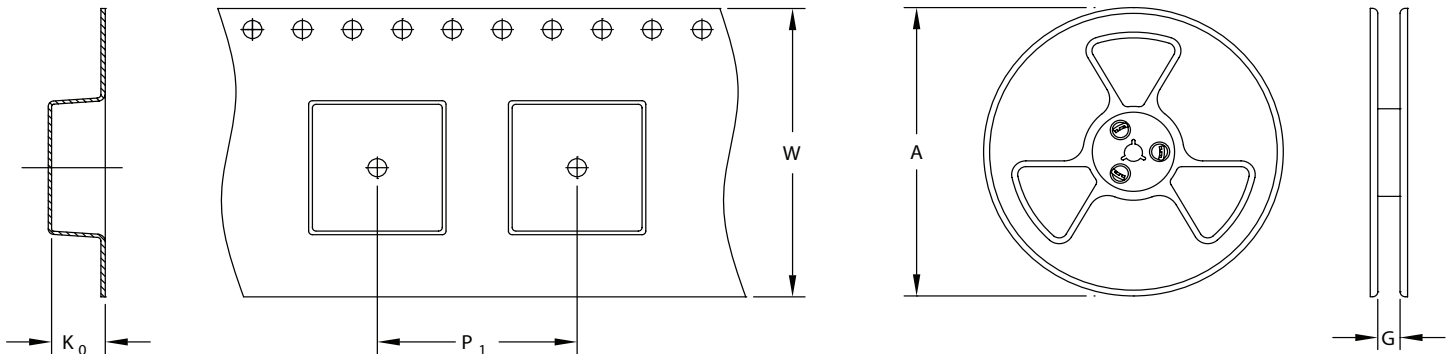

SURFACE MOUNTING TYPE, REEL/TAPE LIST

PART NUMBER	REEL SIZE (mm)		TAPE SIZE (mm)			QTY
	A	G	P_1	W	K_0	PCS/REEL
PE-68386NLT	Ø330	16.4	12	16	3.05	1500
P0926NLT	Ø330	16.4	12	16	5.33	1000
P0544NLT	Ø330	24.4	16	24	8.13	400
PA0264NLT	Ø330	24.4	16	24	3.81	800
PA1323NLT	Ø330	16.4	12	16	5.55	870
PA0173NLT	Ø330	24.4	16	24	4.32	900
PA0185NLT	Ø330	24.4	16	24	4.32	900
PA0184NLT	Ø330	24.4	16	24	8.13	400
PA0297NLT	Ø330	24.4	16	24	8.13	400
PA2777NLT	Ø330	16.4	12	16	6.10	850
PA0510NLT	Ø330	24.4	16	24	8.13	400
PA3493NLT	Ø330	24.4	16	24	2.80	1250

For More Information

Pulse Worldwide Headquarters

15255 Innovation Drive Ste 100
San Diego, CA 92128
U.S.A.

Pulse Europe

Pulse Electronics GmbH
Am Rottland 12
58540 Meinerzhagen
Germany

Pulse China Headquarters

Pulse Electronics (ShenZhen) CO., LTD
D708, Shenzhen Academy of
Aerospace Technology,
The 10th Keji South Road,
Nanshan District, Shenzhen,
P.R. China 518057

Pulse North China

Room 2704/2705
Super Ocean Finance Ctr.
2067 Yan An Road West
Shanghai 200336
China

Pulse South Asia

3 Fraser Street 0428
DUO Tower
Singapore 189352

Pulse North Asia

1F., No.111 Xiyuan Road
Zhongli District
Taoyuan City 32057
Taiwan (R.O.C)

Tel: 858 674 8100
Fax: 858 674 8262

Tel: 49 2354 777 100
Fax: 49 2354 777 168

Tel: 86 755 33966678
Fax: 86 755 33966700

Tel: 86 21 62787060
Fax: 86 2162786973

Tel: 65 6287 8998
Fax: 65 6280 0080

Tel: 886 3 4356768
Fax: 886 3 4356820

Performance warranty of products offered on this data sheet is limited to the parameters specified. Data is subject to change without notice. Other brand and product names mentioned herein may be trademarks or registered trademarks of their respective owners. © Copyright, 2020. Pulse Electronics, Inc. All rights reserved.

Компания «Life Electronics» занимается поставками электронных компонентов импортного и отечественного производства от производителей и со складов крупных дистрибьюторов Европы, Америки и Азии.

С конца 2013 года компания активно расширяет линейку поставок компонентов по направлению коаксиальный кабель, кварцевые генераторы и конденсаторы (керамические, пленочные, электролитические), за счёт заключения дистрибьюторских договоров

Мы предлагаем:

- Конкуренспособные цены и скидки постоянным клиентам.
- Специальные условия для постоянных клиентов.
- Подбор аналогов.
- Поставку компонентов в любых объемах, удовлетворяющих вашим потребностям.
- Приемлемые сроки поставки, возможна ускоренная поставка.
- Доставку товара в любую точку России и стран СНГ.
- Комплексную поставку.
- Работу по проектам и поставку образцов.
- Формирование склада под заказчика.
- Сертификаты соответствия на поставляемую продукцию (по желанию клиента).
- Тестирование поставляемой продукции.
- Поставку компонентов, требующих военную и космическую приемку.
- Входной контроль качества.
- Наличие сертификата ISO.

В составе нашей компании организован Конструкторский отдел, призванный помогать разработчикам, и инженерам.

Конструкторский отдел помогает осуществить:

- Регистрацию проекта у производителя компонентов.
- Техническую поддержку проекта.
- Защиту от снятия компонента с производства.
- Оценку стоимости проекта по компонентам.
- Изготовление тестовой платы монтаж и пусконаладочные работы.



Тел: +7 (812) 336 43 04 (многоканальный)
Email: org@lifeelectronics.ru