

Product number
SEE TABLE, SHEET 5

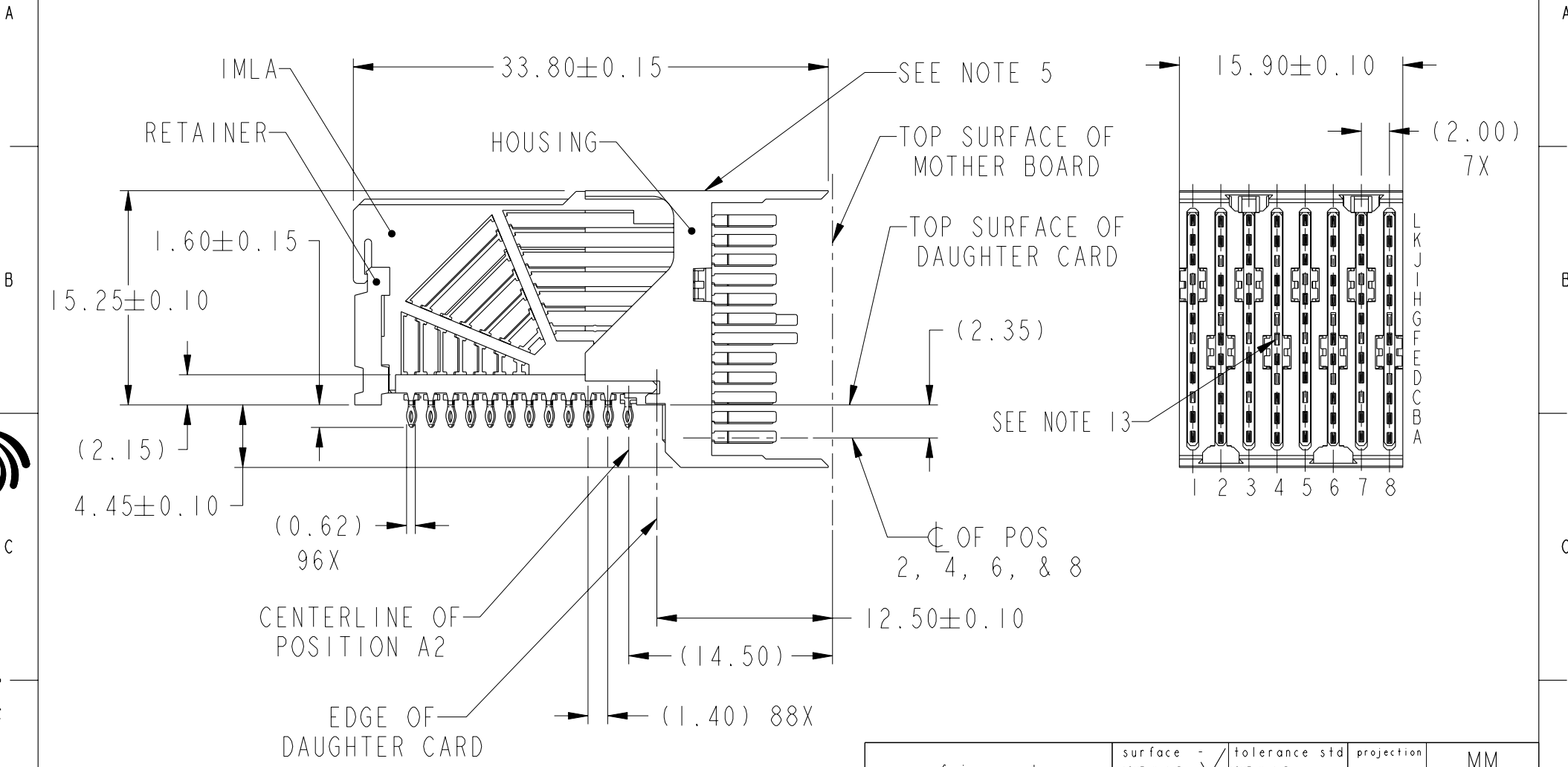

Copyright FCI.

rev	ecn no	dr	date
A	S07-0103	LS	2007-04-05
B	S08-0251	CH	2008-07-31
-	-	-	-
-	-	-	-
-	-	-	-
-	-	-	-

www.fciconnect.com		surface - ASME Y14.5	tolerance std - ASME Y14.5	projection	MM
		TOLERANCES UNLESS OTHERWISE SPECIFIED			
Dr	T. HOUTZ	2005-06-24	ANGULAR	size A4	Scale 5:2
Eng	C. SHELLY	2005-06-24	LINEAR	ECN	***
Chr	C. H TAN	2008-07-31	0° ±°	Product family AirMax VS	Spec ref
Appr	JOEY NG	2008-07-31	0.X ±		
		0.XX ±		dwg no 10052837	Rev. B
		0.XXX ±		CUSTOMER	sheet 1 of 5

REV F - 2006-04-17

DESCRIPTION	DIM A	DIM B	DIM C
2-16MM MODULES PLACED END-TO-END	2.00	15.90 2X	16.00
1-16MM MODULE & 1-18MM MODULE PLACED END-TO-END	3.00	15.90 1X & 17.90 1X	17.00

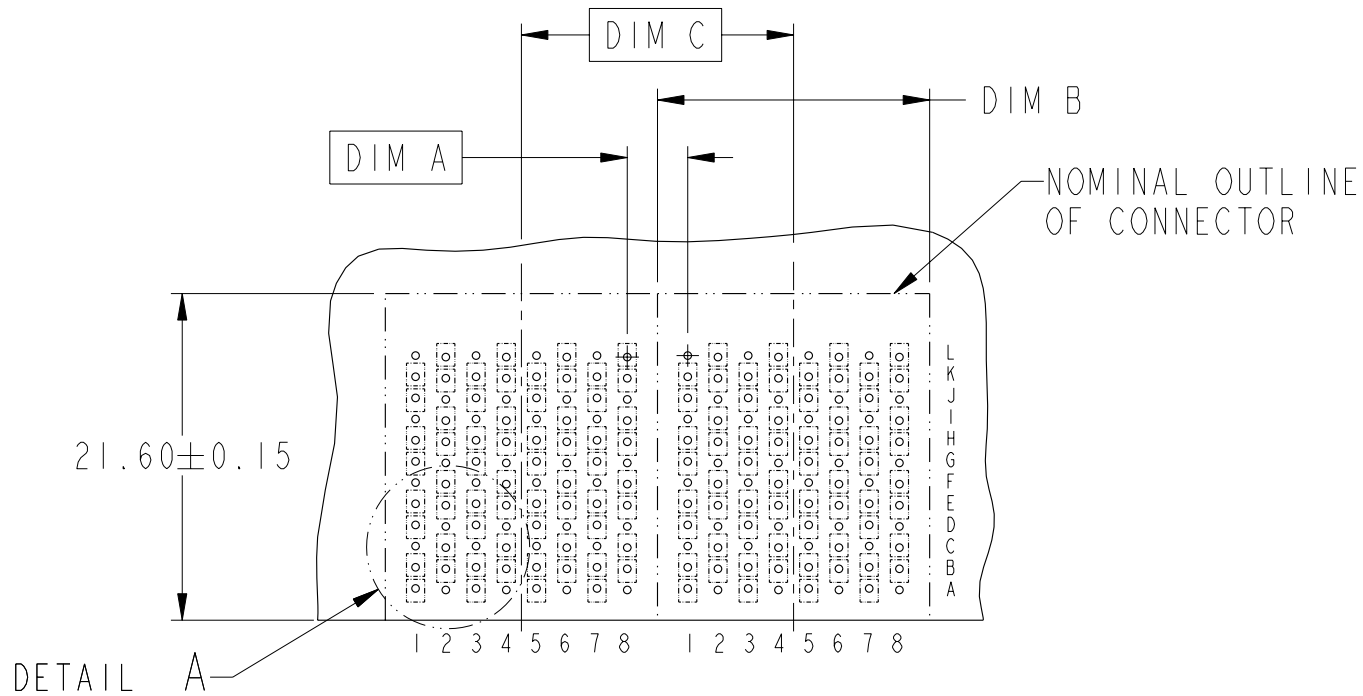

RECOMMENDED PCB LAYOUT
FOR DIFFERENTIAL APPLICATIONS
COMPONENT SIDE
(TWO ADJACENT FOOTPRINTS SHOWN)
NOTES 6 & 7



title	AirMax VS R/A HEADER ASSY	dwg no	10052837	Rev.	B
	PRESS-FIT, 96 POS, 16MM				
catalog no	-	CUSTOMER	sheet 2 of 5		



DESCRIPTION	DIM D	DIM E	DIM F
2-16MM MODULES PLACED END-TO-END	2.00	15.90 2X	16.00
1-16MM MODULE & 1-18MM MODULE PLACED END-TO-END	3.00	15.90 1X & 17.90 1X	17.00

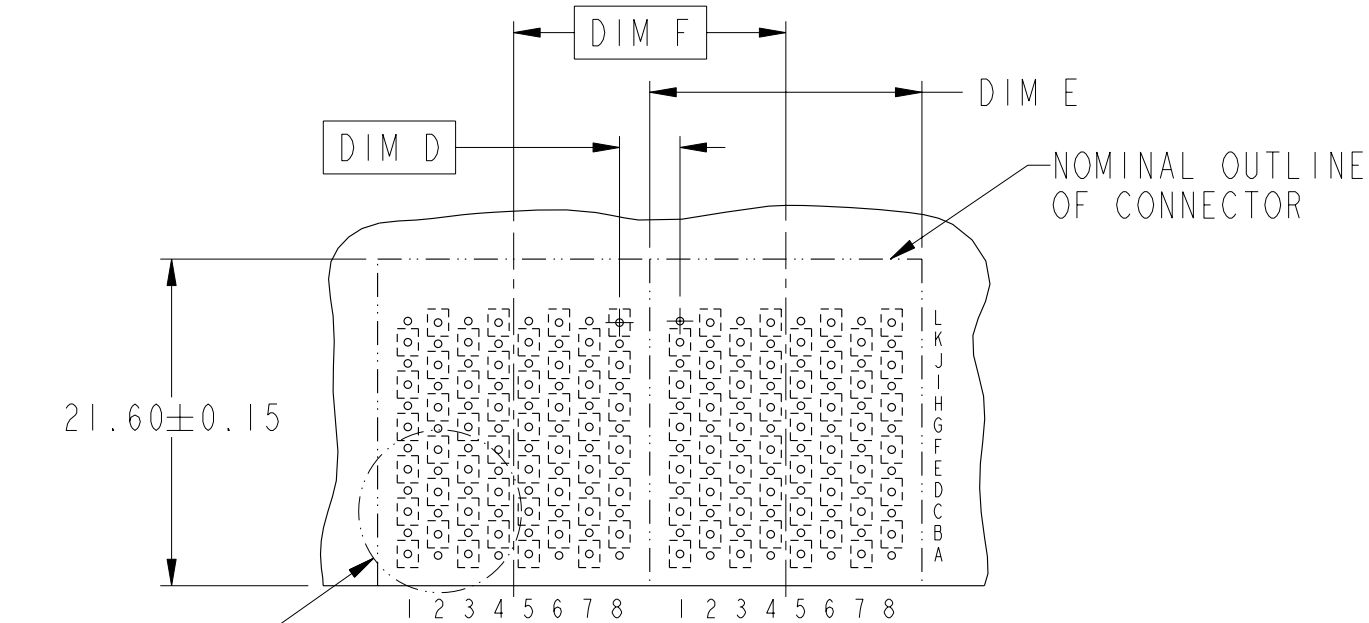

DETAIL B

RECOMMENDED PCB LAYOUT
FOR SINGLE ENDED APPLICATIONS
COMPONENT SIDE
(TWO ADJACENT FOOTPRINTS SHOWN)
NOTES 6 & 7

	TITLE AirMax VS R/A HEADER ASSY PRESS-FIT, 96 POS, 16MM	dwg no 10052837	Rev. B
	catalog no -	CUSTOMER	sheet 3 of 5



Copyright FCI.

REV F - 2006-04-17

SEE NOTE 9
 $\varnothing 0.10$
 ALL HOLES

ANTIPAD WIDTH =
 $2.0 - (\text{TRACE} + \text{SPACE} + \text{TRACE})$
 TYP

2.00 TYP

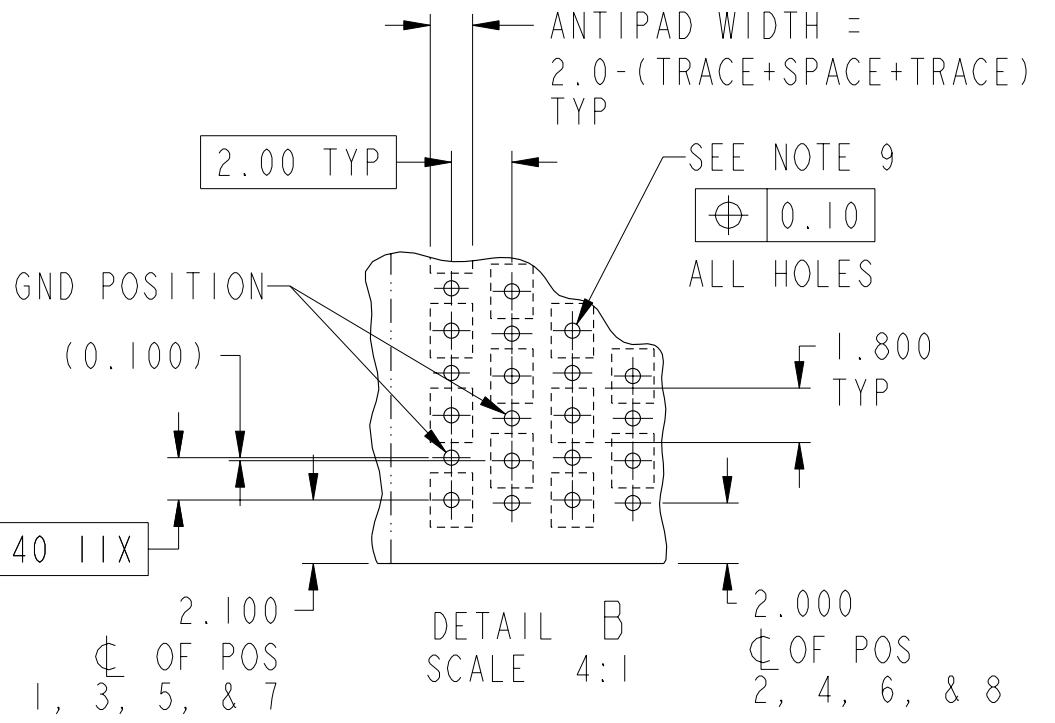
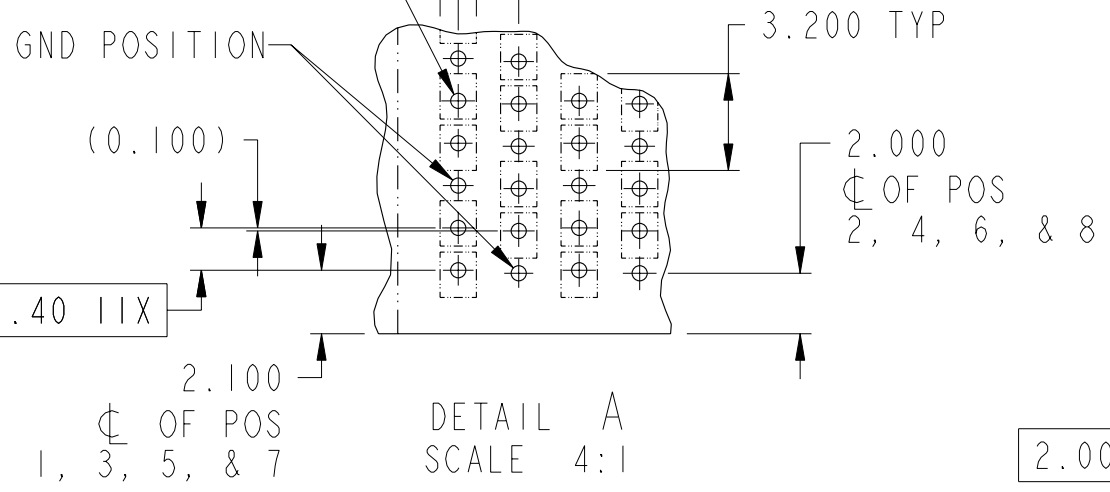

Part no AirMax VS R/A HEADER ASSY
 PRESS-FIT, 96 POS, 16MM
 catalog no -

dwg no 10052837
 CUSTOMER

Rev. B
 sheet 4 of 5

PART NUMBER	PRESS-FIT TAIL PLATING TYPE	SHORT DETECT CONTACT
10052837-101	TIN/LEAD ALLOY OVER NICKEL	NO
10052837-101LF	TIN OVER NICKEL (LEAD FREE)	
10052837-111	TIN/LEAD ALLOY OVER NICKEL	YES (SEE NOTE 13)
10052837-111LF	TIN OVER NICKEL (LEAD FREE)	

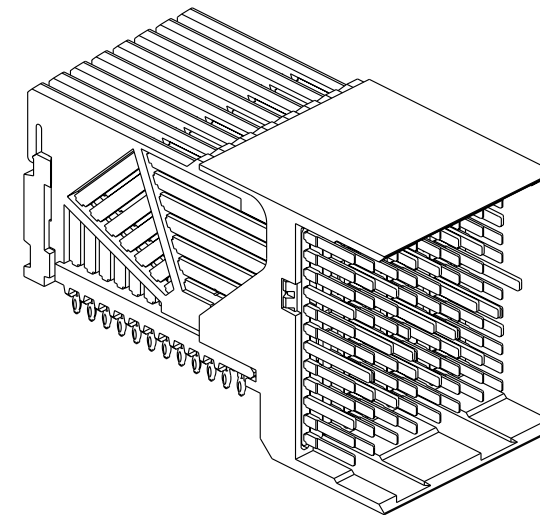

NOTES:

1. CONNECTOR MATERIALS:
 HOUSING & RETAINER: HIGH TEMP THERMOPLASTIC, NATURAL, UL94V-0
 IMLA PLASTIC: HIGH TEMP THERMOPLASTIC, BLACK, UL94V-0
 CONTACT: COPPER ALLOY

2. CONTACT PLATING:
 SEPARABLE INTERFACE:
 PERFORMANCE-BASED PLATING, QUALIFIED TO MEET THE REQUIREMENTS OF FCI PRODUCT SPECIFICATION GS-12-239, INCLUDING TELCORDIA GR-1217-CORE (NOVEMBER 1995) CENTRAL OFFICE.
 PRESS-FIT TAILS: SEE TABLE

3. PRODUCT SPECIFICATION: GS-12-239

4. APPLICATION SPECIFICATION: GS-20-035

5. PRODUCT MARKING, (PART NUMBER & LOT CODE), ON THIS SURFACE

6. REFER TO CUSTOMER DRAWING 10035911 FOR INFORMATION REGARDING PCB LAYOUT OF POWER AND GUIDE MODULES RELATIVE TO SIGNAL MODULES

7. POSITIONS F OF ODD NUMBERED COLUMNS AND POSITIONS G OF EVEN NUMBERED COLUMNS CORRESPOND TO EARLY MATE HEADER PINS

8. THERE IS NO GROUND BUSSING WITHIN THE CONNECTOR SYSTEM

9. REFER TO CUSTOMER DRAWING 10045979 FOR INFORMATION ON PCB HOLE DIAMETERS AND PLATING OPTIONS.

10. THIS PRODUCT MEETS EUROPEAN UNION DIRECTIVES AND OTHER COUNTRY REGULATIONS AS DESCRIBED IN GS-22-008.

11. THE HOUSING WILL WITHSTAND EXPOSURE TO 260°C PEAK TEMPERATURE FOR 40 SECONDS IN A CONVECTION, INFRA-RED OR VAPOR PHASE REFLOW OVEN.

12. PACKAGING MEETS GS-14-920 LEAD FREE LABELING SPECIFICATION.

13.  MATING PIN F4 IS SHORTER THAN ALL REMAINING SIGNAL PINS. NOMINAL MATING WIPE FOR PIN F4 IS 0.5MM LESS THAN ALL REMAINING SIGNAL PINS.

14. A  SYMBOL WILL BE NEXT TO ANY DIMENSION, VIEW, OR NOTE WHICH HAS BEEN MODIFIED WITH THE CURRENT DRAWING REVISION.



Copyright FCI.

	title AirMax VS R/A HEADER ASSY PRESS-FIT, 96 POS, 16MM	dwg no 10052837	Rev. B
	catalog no -	CUSTOMER	sheet 5 of 5

Компания «Life Electronics» занимается поставками электронных компонентов импортного и отечественного производства от производителей и со складов крупных дистрибьюторов Европы, Америки и Азии.

С конца 2013 года компания активно расширяет линейку поставок компонентов по направлению коаксиальный кабель, кварцевые генераторы и конденсаторы (керамические, пленочные, электролитические), за счёт заключения дистрибьюторских договоров

Мы предлагаем:

- Конкуренспособные цены и скидки постоянным клиентам.
- Специальные условия для постоянных клиентов.
- Подбор аналогов.
- Поставку компонентов в любых объемах, удовлетворяющих вашим потребностям.
- Приемлемые сроки поставки, возможна ускоренная поставка.
- Доставку товара в любую точку России и стран СНГ.
- Комплексную поставку.
- Работу по проектам и поставку образцов.
- Формирование склада под заказчика.
- Сертификаты соответствия на поставляемую продукцию (по желанию клиента).
- Тестирование поставляемой продукции.
- Поставку компонентов, требующих военную и космическую приемку.
- Входной контроль качества.
- Наличие сертификата ISO.

В составе нашей компании организован Конструкторский отдел, призванный помогать разработчикам, и инженерам.

Конструкторский отдел помогает осуществить:

- Регистрацию проекта у производителя компонентов.
- Техническую поддержку проекта.
- Защиту от снятия компонента с производства.
- Оценку стоимости проекта по компонентам.
- Изготовление тестовой платы монтаж и пусконаладочные работы.



Тел: +7 (812) 336 43 04 (многоканальный)

Email: org@lifeelectronics.ru