

NHD-0.95-9664G

Graphic Color OLED Display

NHD-	Newhaven Display
0.95-	0.95" Diagonal Size
9664-	96 x 64 Pixels
G-	OLED Glass

Newhaven Display International, Inc.

2661 Galvin Ct.

Elgin IL, 60124

Ph: 847-844-8795

Fax: 847-844-8796

www.newhavendisplay.com

nhtech@newhavendisplay.com

nhsales@newhavendisplay.com

Document Revision History

Revision	Date	Description	Changed by
-	1/21/19	Initial Release	ML

Functions and Features

- 96 x 64 pixel resolution
- Built-in SSD1331 controller
- Serial or Parallel interface
- RoHS compliant

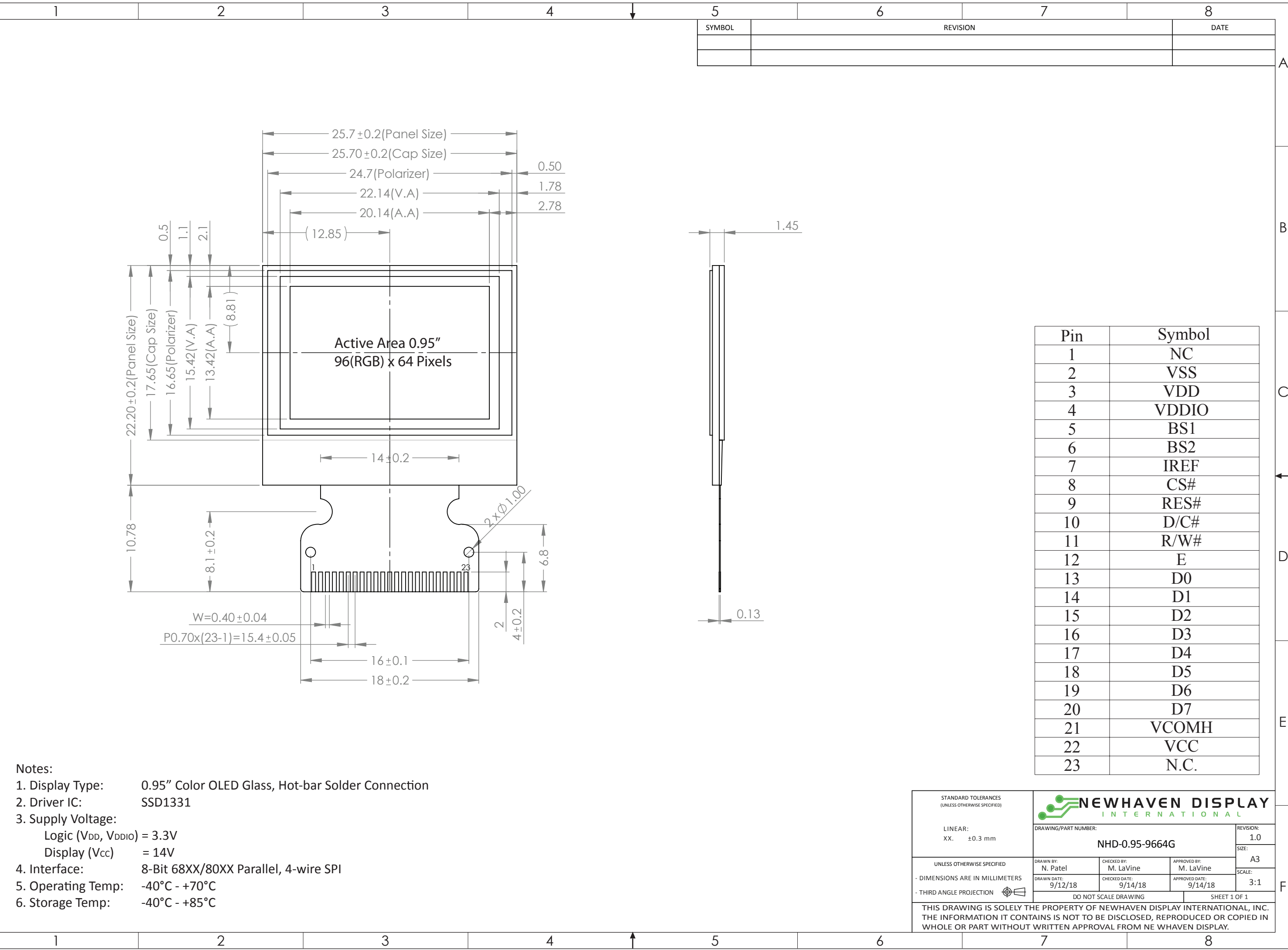

SYMBOL	REVISION	DATE

Pin	Symbol
1	NC
2	VSS
3	VDD
4	VDDIO
5	BS1
6	BS2
7	IREF
8	CS#
9	RES#
10	D/C#
11	R/W#
12	E
13	D0
14	D1
15	D2
16	D3
17	D4
18	D5
19	D6
20	D7
21	VCOMH
22	VCC
23	N.C.

- Notes:
1. Display Type: 0.95" Color OLED Glass, Hot-bar Solder Connection
 2. Driver IC: SSD1331
 3. Supply Voltage:
 - Logic (V_{DD}, V_{DDIO}) = 3.3V
 - Display (V_{CC}) = 14V
 4. Interface: 8-Bit 68XX/80XX Parallel, 4-wire SPI
 5. Operating Temp: -40°C - +70°C
 6. Storage Temp: -40°C - +85°C

STANDARD TOLERANCES (UNLESS OTHERWISE SPECIFIED)

LINEAR: ±0.3 mm

UNLESS OTHERWISE SPECIFIED

- DIMENSIONS ARE IN MILLIMETERS

- THIRD ANGLE PROJECTION

DO NOT SCALE DRAWING

SHEET 1 OF 1

THIS DRAWING IS SOLELY THE PROPERTY OF NEWHAVEN DISPLAY INTERNATIONAL, INC. THE INFORMATION IT CONTAINS IS NOT TO BE DISCLOSED, REPRODUCED OR COPIED IN WHOLE OR PART WITHOUT WRITTEN APPROVAL FROM NEWHAVEN DISPLAY.

NEWHAVEN DISPLAY INTERNATIONAL

DRAWING/PART NUMBER: NHD-0.95-9664G

REVISION: 1.0

SIZE: A3

SCALE: 3:1

DRAWN BY: N. Patel	CHECKED BY: M. LaVine	APPROVED BY: M. LaVine
DRAWN DATE: 9/12/18	CHECKED DATE: 9/14/18	APPROVED DATE: 9/14/18

Interface Description

Pin No.	Symbol	External Connection	Function Description
1	NC	-	No connect (can be tied to Ground)
2	V _{SS}	Power Supply	Ground
3	V _{DD}	Power Supply	Supply voltage for Logic
4	V _{DDIO}	Power Supply	Supply voltage for I/O
5	BS1	MPU	MPU interface select signal
6	BS2	MPU	MPU interface select signal
7	I _{REF}	Power Supply	Current reference for brightness adjustment
8	CS#	MPU	Active LOW Chip Select signal
9	RES#	MPU	Active LOW Reset signal
10	D/C#	MPU	Data/Command selection. LOW: Command. HIGH: Data
11	R/W# WR#	MPU	6800 mode: Read/Write signal. LOW: Write. HIGH: Read 8080 mode: Active LOW Write signal
12	E RD#	MPU	6800 mode: Enable signal. Falling edge triggered 8080 mode: Active LOW Read signal
13	D0	MPU	Parallel interface: 8-bit bi-directional data bus Serial interface: D0 = Serial Clock signal (SCLK) D1 = Serial Data Input signal (SDIN)
14	D1	MPU	
15	D2	MPU	
16	D3	MPU	
17	D4	MPU	
18	D5	MPU	
19	D6	MPU	
20	D7	MPU	
21	V _{COMH}	Power Supply	Voltage output high level for COM signal
22	V _{CC}	Power Supply	Supply voltage for OLED panel
23	NC	-	No connect

Recommended display connector: n/a (Hot-bar solder directly to PCB)

MPU Interface Pin Assignment Summary

Bus Interface	D7	D6	D5	D4	D3	D2	D1	D0	E	R/W	BS1	BS2	/CS	D/C	/RES
8-bit 6800	D[7:0]								RD#	WR#	1	1	/CS	D/C	/RES
8-bit 8080	D[7:0]								E	R/W#	0	1	/CS	D/C	/RES
4-wire SPI	0				NC	SDIN	SCLK	0	0	0	0	/CS	D/C	/RES	

Note:

- “NC” : No Connect
- “1” : VDD
- “0” : VSS

Wiring Diagram

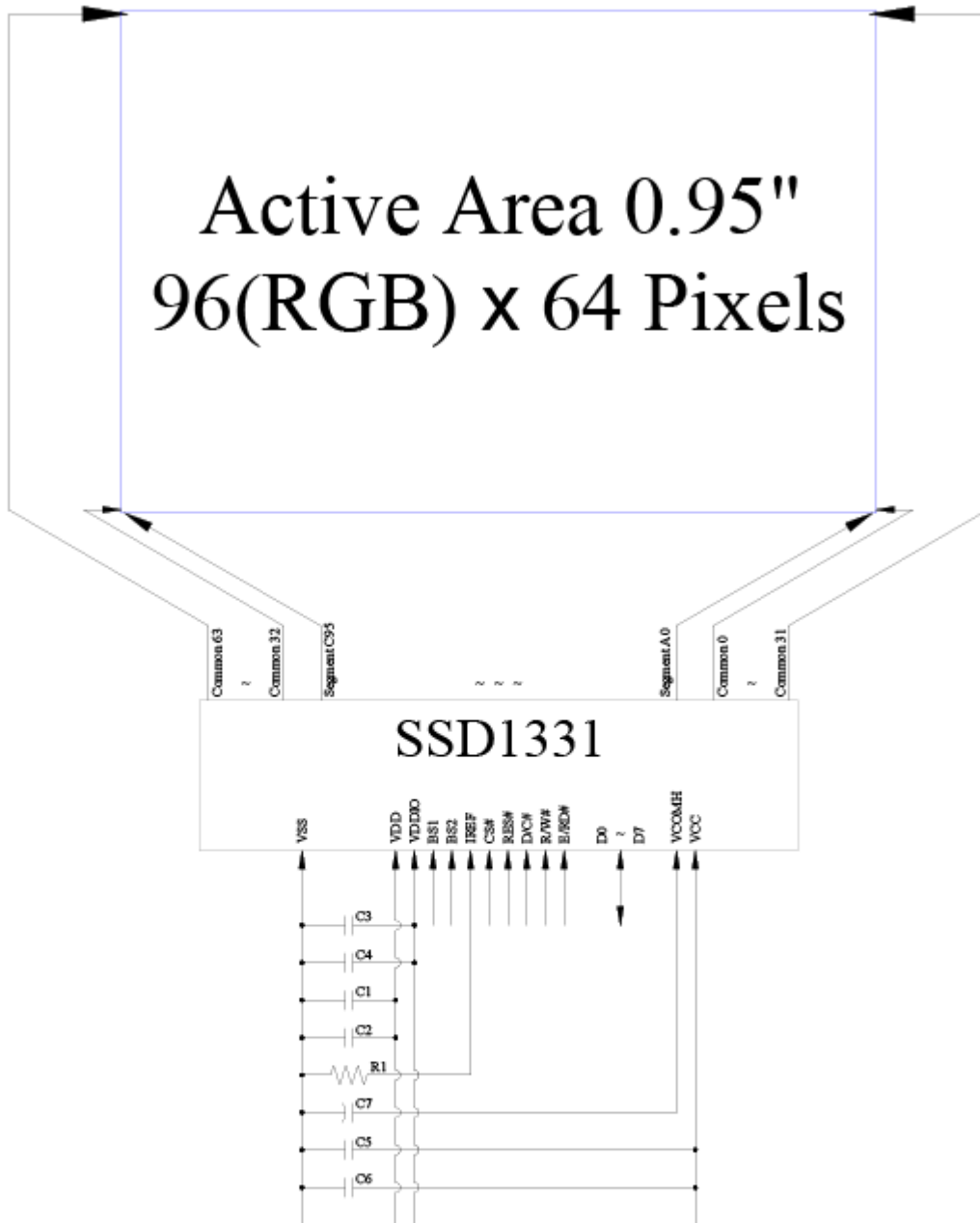

MCU Interface Selection: BS1 and BS2
 Pins connected to MCU interface: CS#, RES#, D/C#, R/W#, E/RD#, and D0~D7

C1, C3, C5: 0.1 μ F
 C2, C4: 4.7 μ F
 C6: 10 μ F
 C7: 4.7 μ F / 25V Tantalum Capacitor
 R1: 1.2M Ω , $R1 = (\text{Voltage at IREF} - \text{VSS}) / \text{IREF}$

Electrical Characteristics

Item	Symbol	Condition	Min.	Typ.	Max.	Unit
Operating Temperature Range	T _{OP}	Absolute Max	-40	-	+70	°C
Storage Temperature Range	T _{ST}	Absolute Max	-40	-	+85	°C
Supply Voltage for Logic	V _{DD}	-	2.4	2.8	3.5	V
Supply Voltage for I/O Pins	V _{DDIO}	-	1.6	2.8	V _{DD}	
Supply Voltage for Display	V _{CC}	-	13.5	14.0	14.5	V
Supply Current for Logic	I _{DD}	V _{DD} = 2.8V; 100% On	-	200	600	μA
Supply Current for Display	I _{CC}	V _{CC} = 14V; 50% On	-	8.0	11.0	mA
		V _{CC} = 14V; 100% On	-	13.5	18.0	mA
Supply Current (Sleep)	I _{SLEEP}	V _{DD} = 2.8V	-	3	15	μA
"H" Level input	V _{IH}	-	0.8 * V _{DDIO}	-	V _{DDIO}	V
"L" Level input	V _{IL}	-	V _{SS}	-	0.2 * V _{DDIO}	V
"H" Level output	V _{OH}	-	0.9 * V _{DDIO}	-	V _{DDIO}	V
"L" Level output	V _{OL}	-	V _{SS}	-	0.1 * V _{DDIO}	V

Optical Characteristics

Item	Symbol	Condition	Min.	Typ.	Max.	Unit
Optimal Viewing Angles	Top		80	-	-	°
	Bottom		80	-	-	°
	Left		80	-	-	°
	Right		80	-	-	°
Contrast Ratio	CR	-	-	>10,000:1	-	
Response Time (rise)	T _R	-	-	10	-	μs
Response Time (fall)	T _F	-	-	10	-	μs
Brightness	L _V	50% Checkerboard	80	100	-	cd/m ²
Lifetime	-	100 cd/m ² , T _{OP} =25°C 50% Checkerboard	10,000	-	-	Hrs

Note: Lifetime at typical temperature is based on accelerated high-temperature operation. Lifetime is tested at average 50% pixels on and is rated as Hours until **Half-Brightness**. The Display OFF command can be used to extend the lifetime of the display.

Luminance of active pixels will degrade faster than inactive pixels. Residual (burn-in) images may occur. To avoid this, every pixel should be illuminated uniformly.

Controller information

Built-in SSD1331 controller.

Please download specification at <http://www.newhavendisplay.com/appnotes/datasheets/OLEDs/SSD1331.pdf>

Table of Commands

Fundamental Commands													
D/C#	Hex	D7	D6	D5	D4	D3	D2	D1	D0	Command	Description	Default	
0 0 0	15 A[6:0] B[6:0]	0 *	0 A ₆	0 A ₅	1 A ₄	0 A ₃	1 A ₂	0 A ₁	1 A ₀	Set Column Address	Setup Column start and end address A[6:0] start address from 00d-95d B[6:0] end address from 00d-95d	00d (00h) 95d (5Fh)	
0 0 0	75 A[5:0] B[5:0]	0 *	1 *	1 A ₅	1 A ₄	0 A ₃	1 A ₂	0 A ₁	1 A ₀		Set Row Address	Setup Row start and end address A[5:0] start address from 00d-63d B[5:0] end address from 00d-63d	00d (00h) 63d (3Fh)
0 0	81 A[7:0]	1 A ₇	0 A ₆	0 A ₅	0 A ₄	0 A ₃	0 A ₂	0 A ₁	1 A ₀			Set Contrast for Color "A"	Set contrast for all color "A" segment (Pins:SA0 – SA95) A[7:0] valid range: 00d to 255d
0 0	82 A[7:0]	1 A ₇	0 A ₆	0 A ₅	0 A ₄	0 A ₃	0 A ₂	1 A ₁	0 A ₀	Set Contrast for Color "B"			Set contrast for all color "B" segment (Pins:SB0 – SB95). A[7:0] valid range: 00d to 255d
0 0	83 A[7:0]	1 A ₇	0 A ₆	0 A ₅	0 A ₄	0 A ₃	0 A ₂	1 A ₁	1 A ₀		Set Contrast for Color "C"		Set contrast for all color "C" segment (Pins:SC0 – SC95). A[7:0] valid range: 00d to 255d
0 0	87 A[3:0]	1 0	0 0	0 0	0 0	0 A ₃	1 A ₂	1 A ₁	1 A ₀			Master Current Control	Set master current attenuation factor A[3:0] from 00d to 15d corresponding to 1/16, 2/16... to 16/16 attenuation.

Fundamental Commands																				
D/C#	Hex	D7	D6	D5	D4	D3	D2	D1	D0	Command	Description	Default								
0 0 0 0 0 0	8A A[7:0] 8B A[7:0] 8C A[7:0]	1 A ₇	0 A ₆	0 A ₅	0 A ₄	1 A ₃	0 A ₂	1 A ₁	0 A ₀	Set Second Pre-charge Speed for Color "A", "B" and "C"	<p>A[7:0]: Set Second Pre-charge Speed Ranges: 0000000b to 1111111b, a higher value of A[7:0] gives a higher Second Pre-charge speed.</p> <p>Note ⁽¹⁾ The default values of A[7:0] in 8Ah, A[7:0] in 8Bh and A[7:0] in 8Ch are equal to the contrast values for color A, B and C(refer to commands: 81h, 82h, 83h) respectively. ⁽²⁾ All six bytes (8Ah A[7:0], 8Bh A[7:0] and 8Ch A[7:0]) must be inputted together. For example: the original value is like that</p> <table border="1"> <thead> <tr> <th colspan="2">Original value</th> </tr> </thead> <tbody> <tr> <td>8Ah A[7:0]:</td> <td>80h</td> </tr> <tr> <td>8Bh A[7:0]:</td> <td>80h</td> </tr> <tr> <td>8Ch A[7:0]:</td> <td>80h</td> </tr> </tbody> </table> <p>If it is wanted to change the value of 8Bh A[7:0] to 75h, then all the following 6 bytes must be inputted: 8Ah,80h, 8Bh,75h, 8Ch,80h.</p>	Original value		8Ah A[7:0]:	80h	8Bh A[7:0]:	80h	8Ch A[7:0]:	80h	A[7:0] of 81h A[7:0] of 82h A[7:0] of 83h
Original value																				
8Ah A[7:0]:	80h																			
8Bh A[7:0]:	80h																			
8Ch A[7:0]:	80h																			
0 0	A0 A[7:0]	1 A ₇	0 A ₆	1 A ₅	0 A ₄	0 A ₃	0 A ₂	0 A ₁	0 A ₀			Remap & Color Depth setting	Set driver remap and color depth A[0]=0, Horizontal address increment A[0]=1, Vertical address increment A[1]=0, RAM Column 0 to 95 maps to Pin Seg (SA,SB,SC) 0 to 95 A[1]=1, RAM Column 0 to 95 maps to Pin Seg (SA,SB,SC) 95 to 0 A[2]=0, normal order SA,SB,SC (e.g. RGB) A[2]=1, reverse order SC,SB,SA (e.g. BGR) A[3]=0, Disable left-right swapping on COM A[3]=1, Set left-right swapping on COM A[4]=0, Scan from COM 0 to COM [N -1] A[4]=1, Scan from COM [N-1] to COM0. Where N is the multiplex ratio. A[5]=0, Disable COM Split Odd Even (RESET) A[5]=1, Enable COM Split Odd Even A[7:6] = 00; 256 color format A[7:6] = 01; 65k color format A[7:6] = 10; 65k color format 2 If 9 / 18 bit mode is selected, color depth will be fixed to 65k regardless of the setting.	A[0]=0 A[1]=0 A[2]=0 A[3]=0 A[4]=0 A[5]=0 A[7:6]=01						
0 0	A1 A[5:0]	1 0	0 0	1 A ₅	0 A ₄	0 A ₃	0 A ₂	0 A ₁	1 A ₀	Set Display Start Line	Set display start line register by Row A[5:0]: from 00d to 63d		00d (00h)							
0 0	A2 A[5:0]	1 0	0 0	1 A ₅	0 A ₄	0 A ₃	0 A ₂	1 A ₁	0 A ₀	Set Display Offset	Set vertical offset by Com A[5:0]: from 00d to 63d		00d (00h)							

Fundamental Commands												
D/C#	Hex	D7	D6	D5	D4	D3	D2	D1	D0	Command	Description	Default
00	A4 / A5 / A6 / A7 /	1	0	1	0	0	1	X ₁	X ₀	Set Display Mode	A4h=Normal Display A5h=Entire Display ON, all pixels turn ON at GS63 A6h=Entire Display OFF, all pixels turn OFF A7h=Inverse Display	A4h
00	A8 A[5:0]	1 0	0 0	1 A ₅	0 A ₄	1 A ₃	0 A ₂	0 A ₁	0 A ₀	Set Multiplex Ratio	Set MUX ratio to N+1 Mux N = A[5:0] from 15d to 63d A[5:0] from 00d to 14d are invalid entry	63d (3Fh)
000000	AB A[7:0] B[7:0] C[7:0] D[7:0] E[4:0]	1 A ₇	0 A ₆	1 A ₅	0 A ₄	1 A ₃	0 A ₂	1 A ₁	1 A ₀	Dim Mode Setting	Configure dim mode setting A[7:0] = Reserved. (Set as 00h) B[7:0] = Contrast setting for Color A, valid range 0 to 255d. C[7:0] = Contrast setting for Color B, valid range 0 to 255d. D[7:0] = Contrast setting for Color C, valid range 0 to 255d. E[4:0] = Precharge voltage setting, valid range 0 to 31d.	\
00	AD A[0]	1 1	0 0	1 0	0 0	1 1	1 1	0 1	1 A ₀	Set Master Configuration	A[0]=0b, Select external V _{CC} supply A[0]=1b, Reserved (RESET) Note (1) Bit A[0] must be set to 0b after RESET. (2) The setting will be activated after issuing Set Display ON command (AFh)	A[0] = 1
0	AC AE AF	1	0	1	0	1	1	A ₁	A ₀	Set Display ON/OFF	ACH = Display ON in dim mode AEh = Display OFF (sleep mode) AFh = Display ON in normal mode	AEh
00	B0 A[7:0]	1 A ₇	0 A ₆	1 A ₅	1 A ₄	0 A ₃	0 A ₂	0 A ₁	0 A ₀	Power Save Mode	A[7:0]=1Ah, Enable Power save mode (RESET) A[7:0]=0Bh, Disable Power save mode	1Ah
00	B1 A[7:0]	1 A ₇	0 A ₆	1 A ₅	1 A ₄	0 A ₃	0 A ₂	0 A ₁	1 A ₀	Phase 1 and 2 period adjustment	A[3:0] Phase 1 period in N DCLK. 1~15 DCLK allowed. A[7:4] Phase 2 period in N DCLK. 1~15 DCLK allowed Note (1) 0 DCLK is invalid in phase 1 & phase 2	74h
00	B3 A[7:0]	1 A ₇	0 A ₆	1 A ₅	1 A ₄	0 A ₃	0 A ₂	1 A ₁	1 A ₀	Display Clock Divider / Oscillator Frequency	A[3:0]: Define the divide ratio (D) of the display clocks (DCLK): Divide ratio (D) = A[3:0] + 1 (i.e., 1 to 16) A[7:4] Fosc frequency. Frequency increases as setting value increases	D0h

Fundamental Commands																														
D/C#	Hex	D7	D6	D5	D4	D3	D2	D1	D0	Command	Description	Default																		
0	B8	1	0	1	1	1	0	0	0	Set Gray Scale Table	These 32 parameters define pulse widths of GS1 to GS63 in terms of DCLK A[6:0]: Pulse width for GS1, RESET=01d B[6:0]: Pulse width for GS3, RESET=05d C[6:0]: Pulse width for GS5, RESET=09d AE[6:0]: Pulse width for GS61, RESET=121d AF[6:0]: Pulse width for GS63, RESET=125d Note: ⁽¹⁾ GS0 has no pre-charge and current drive stages. ⁽²⁾ GS2, GS4...GS62 are derived by $P_n = (P_{n-1} + P_{n+1})/2$ ⁽³⁾ P_n will be truncated to integer if it is with decimal point. ⁽⁴⁾ P_{n+1} should always be set to larger than P_{n-1} ⁽⁵⁾ Max pulse width is 125	\																		
0	A[6:0]	*	A ₆	A ₅	A ₄	A ₃	A ₂	A ₁	A ₀																					
0	B[6:0]	*	B ₆	B ₅	B ₄	B ₃	B ₂	B ₁	B ₀																					
0	C[6:0]	*	C ₆	C ₅	C ₄	C ₃	C ₂	C ₁	C ₀																					
0																					
0	AE[6:0]	*	AE ₆	AE ₅	AE ₄	AE ₃	AE ₂	AE ₁	AE ₀																					
0	AF[6:0]	*	AF ₆	AF ₅	AF ₄	AF ₃	AF ₂	AF ₁	AF ₀																					
0	B9	1	0	1	1	1	0	0	1	Enable Linear Gray Scale Table	Reset built in gray scale table (Linear) Pulse width for GS1 = 1d; Pulse width for GS2 = 3d; Pulse width for GS3 = 5d; Pulse width for GS61 = 121d; Pulse width for GS62 = 123d; Pulse width for GS63 = 125d.	\																		
0	BB	1	0	1	1	1	0	1	1	Set Pre-charge level	Set pre-charge voltage level. All three color share the same pre-charge voltage. <table border="1"> <thead> <tr> <th>A[5:1]</th> <th>Hex code</th> <th>pre-charge voltage</th> </tr> </thead> <tbody> <tr> <td>00000</td> <td>00h</td> <td>0.10 x V_{CC}</td> </tr> <tr> <td>:</td> <td>:</td> <td>:</td> </tr> <tr> <td>11111</td> <td>3Eh</td> <td>0.50 x V_{CC}</td> </tr> </tbody> </table> Refer to Figure 30 for the details setting of A[5:1].	A[5:1]	Hex code	pre-charge voltage	00000	00h	0.10 x V _{CC}	:	:	:	11111	3Eh	0.50 x V _{CC}	3Eh						
A[5:1]	Hex code	pre-charge voltage																												
00000	00h	0.10 x V _{CC}																												
:	:	:																												
11111	3Eh	0.50 x V _{CC}																												
0	A[5:0]	0	0	A ₅	A ₄	A ₃	A ₂	A ₁	0																					
0	BC-BD	1	0	1	1	1	1	0	X ₀	NOP	Command for No operation	\																		
0	BE	1	0	1	1	1	1	1	0	Set V _{COMH}	Set COM deselect voltage level (V _{COMH}) <table border="1"> <thead> <tr> <th>A[5:1]</th> <th>Hex code</th> <th>V_{COMH}</th> </tr> </thead> <tbody> <tr> <td>00000</td> <td>00h</td> <td>0.44 x V_{CC}</td> </tr> <tr> <td>01000</td> <td>10h</td> <td>0.52 x V_{CC}</td> </tr> <tr> <td>10000</td> <td>20h</td> <td>0.61 x V_{CC}</td> </tr> <tr> <td>11000</td> <td>30h</td> <td>0.71 x V_{CC}</td> </tr> <tr> <td>11111</td> <td>3Eh</td> <td>0.83 x V_{CC}</td> </tr> </tbody> </table>	A[5:1]	Hex code	V _{COMH}	00000	00h	0.44 x V _{CC}	01000	10h	0.52 x V _{CC}	10000	20h	0.61 x V _{CC}	11000	30h	0.71 x V _{CC}	11111	3Eh	0.83 x V _{CC}	3Eh
A[5:1]	Hex code	V _{COMH}																												
00000	00h	0.44 x V _{CC}																												
01000	10h	0.52 x V _{CC}																												
10000	20h	0.61 x V _{CC}																												
11000	30h	0.71 x V _{CC}																												
11111	3Eh	0.83 x V _{CC}																												
0	A[5:1]	0	0	A ₅	A ₄	A ₃	A ₂	A ₁	0																					
0	E3	1	1	1	0	0	0	1	1	NOP	Command for No operation	\																		
0	FD	1	1	1	1	1	1	0	1	Set Command Lock	A[2]: MCU protection status A[2] = 0b, Unlock OLED driver IC MCU interface from entering command [reset] A[2] = 1b, Lock OLED driver IC MCU interface from entering command Note ⁽¹⁾ The locked OLED driver IC MCU interface prohibits all commands and memory access except the FDh command.	12h																		
0	A[2]	0	0	0	1	0	A ₂	1	0																					

Graphic Acceleration Commands											
D/C#	Hex	D7	D6	D5	D4	D3	D2	D1	D0	Command	Description
0	21	0	0	1	0	0	0	0	1	Draw Line	A[6:0]: Column Address of Start
0	A[6:0]	*	A ₆	A ₅	A ₄	A ₃	A ₂	A ₁	A ₀		B[5:0]: Row Address of Start
0	B[5:0]	*	*	B ₅	B ₄	B ₃	B ₂	B ₁	B ₀		C[6:0]: Column Address of End
0	C[6:0]	*	C ₆	C ₅	C ₄	C ₃	C ₂	C ₁	C ₀		D[5:0]: Row Address of End
0	D[5:0]	*	*	D ₅	D ₄	D ₃	D ₂	D ₁	D ₀		E[5:1]: Color C of the line
0	E[5:1]	*	*	E ₅	E ₄	E ₃	E ₂	E ₁	*		F[5:0]: Color B of the line
0	F[5:0]	*	*	F ₅	F ₄	F ₃	F ₂	F ₁	F ₀		G[5:1]: Color A of the line
0	G[5:1]	*	*	G ₅	G ₄	G ₃	G ₂	G ₁	*		
0	22	0	0	1	0	0	0	1	0	Drawing Rectangle	A[6:0]: Column Address of Start
0	A[6:0]	*	A ₆	A ₅	A ₄	A ₃	A ₂	A ₁	A ₀		B[5:0]: Row Address of Start
0	B[5:0]	*	*	B ₅	B ₄	B ₃	B ₂	B ₁	B ₀		C[6:0]: Column Address of End
0	C[6:0]	*	C ₆	C ₅	C ₄	C ₃	C ₂	C ₁	C ₀		D[5:0]: Row Address of End
0	D[5:0]	*	*	D ₅	D ₄	D ₃	D ₂	D ₁	D ₀		E[5:1]: Color C of the line
0	E[5:1]	*	*	E ₅	E ₄	E ₃	E ₂	E ₁	*		F[5:0]: Color B of the line
0	F[5:0]	*	*	F ₅	F ₄	F ₃	F ₂	F ₁	F ₀		G[5:1]: Color A of the line
0	G[5:1]	*	*	G ₅	G ₄	G ₃	G ₂	G ₁	*		H[5:1]: Color C of the fill area
0	H[5:1]	*	*	H ₅	H ₄	H ₃	H ₂	H ₁	*		I[5:0]: Color B of the fill area
0	I[5:0]	*	*	I ₅	I ₄	I ₃	I ₂	I ₁	I ₀		J[5:1]: Color A of the fill area
0	J[5:1]	*	*	J ₅	J ₄	J ₃	J ₂	J ₁	*		
0	23	0	0	1	0	0	0	1	1	Copy	A[6:0]: Column Address of Start
0	A[6:0]	*	A ₆	A ₅	A ₄	A ₃	A ₂	A ₁	A ₀		B[5:0]: Row Address of Start
0	B[5:0]	*	*	B ₅	B ₄	B ₃	B ₂	B ₁	B ₀		C[6:0]: Column Address of End
0	C[6:0]	*	C ₆	C ₅	C ₄	C ₃	C ₂	C ₁	C ₀		D[5:0]: Row Address of End
0	D[5:0]	*	*	D ₅	D ₄	D ₃	D ₂	D ₁	D ₀		E[6:0]: Column Address of New Start
0	E[6:0]	*	E ₆	E ₅	E ₄	E ₃	E ₂	E ₁	E ₀		F[5:0]: Row Address of New Start
0	F[5:0]	*	*	F ₅	F ₄	F ₃	F ₂	F ₁	F ₀		
0	24	0	0	1	0	0	1	0	0	Dim Window	A[6:0]: Column Address of Start
0	A[6:0]	*	A ₆	A ₅	A ₄	A ₃	A ₂	A ₁	A ₀		B[5:0]: Row Address of Start
0	B[5:0]	*	*	B ₅	B ₄	B ₃	B ₂	B ₁	B ₀		C[6:0]: Column Address of End
0	C[6:0]	*	C ₆	C ₅	C ₄	C ₃	C ₂	C ₁	C ₀		D[5:0]: Row Address of End
0	D[5:0]	*	*	D ₅	D ₄	D ₃	D ₂	D ₁	D ₀		The effect of dim window: GS15~GS0 no change GS19~GS16 become GS4 GS23~GS20 become GS5 ... GS63~GS60 become GS15
0	25	0	0	1	0	0	1	0	1	Clear Window	A[6:0]: Column Address of Start
0	A[6:0]	*	A ₆	A ₅	A ₄	A ₃	A ₂	A ₁	A ₀		B[5:0]: Row Address of Start
0	B[5:0]	*	*	B ₅	B ₄	B ₃	B ₂	B ₁	B ₀		C[6:0]: Column Address of End
0	C[6:0]	*	C ₆	C ₅	C ₄	C ₃	C ₂	C ₁	C ₀		D[5:0]: Row Address of End
0	D[5:0]	*	*	D ₅	D ₄	D ₃	D ₂	D ₁	D ₀		
0	26	0	0	1	0	0	1	1	0	Fill Enable / Disable	A0 0 : Disable Fill for Draw Rectangle Command (RESET)
0	A[4:0]	*	*	*	A ₄	0	0	0	A ₀		1 : Enable Fill for Draw Rectangle Command A[3:1] 000: Reserved values A4 0 : Disable reverse copy (RESET) 1 : Enable reverse during copy command.

Graphic Acceleration Commands											
D/C#	Hex	D7	D6	D5	D4	D3	D2	D1	D0	Command	Description
0	27	0	0	1	0	0	1	1	1	Continuous Horizontal & Vertical Scrolling Setup	A[6:0]: Set number of column as horizontal scroll offset Range: 0d-95d (no horizontal scroll if equals to 0)
0	A[6:0]	*	A ₆	A ₅	A ₄	A ₃	A ₂	A ₁	A ₀		B[5:0]: Define start row address
0	B[5:0]	*	*	B ₅	B ₄	B ₃	B ₂	B ₁	B ₀		C[6:0]: Set number of rows to be horizontal scrolled B[5:0]+C[6:0] <=64
0	C[6:0]	*	C ₆	C ₅	C ₄	C ₃	C ₂	C ₁	C ₀		D[5:0]: Set number of row as vertical scroll offset Range: 0d-63d (no vertical scroll if equals to 0)
0	D[5:0]	*	*	D ₅	D ₄	D ₃	D ₂	D ₁	D ₀		E[1:0]: Set time interval between each scroll step 00b 6 frames 01b 10 frames 10b 100 frames 11b 200 frames
0	E[1:0]	*	*	*	*	*	*	E ₁	E ₀	Note: ⁽¹⁾ Vertical scroll is run with 64MUX setting only ⁽²⁾ The parameters should not be changed after scrolling is activated	
0	2E	0	0	1	0	1	1	1	0	Deactivate scrolling	This command deactivates the scrolling action. Note ⁽¹⁾ After sending 2Eh command to deactivate the scrolling action, the ram data needs to be rewritten.
0	2F	0	0	1	0	1	1	1	1	Activate scrolling	This command activates the scrolling function according to the setting done by Continuous Horizontal & Vertical Scrolling Setup command 27h.

For the full command table descriptions, please download the following:
<http://www.newhavendisplay.com/appnotes/datasheets/OLEDs/SSD1331.pdf>

Timing Characteristics

Parallel (6800 mode):

Symbol	Parameter	Min	Typ	Max	Unit
t_{cycle}	Clock Cycle Time (write cycle)	130	-	-	ns
PW_{CSL}	Control Pulse Low Width (write cycle)	60	-	-	ns
PW_{CSH}	Control Pulse High Width (write cycle)	60	-	-	ns
t_{cycle}	Clock Cycle Time (read cycle)	200	-	-	ns
PW_{CSL}	Control Pulse Low Width (read cycle)	100	-	-	ns
PW_{CSH}	Control Pulse High Width (read cycle)	100	-	-	ns
t_{AS}	Address Setup Time	0	-	-	ns
t_{AH}	Address Hold Time	10	-	-	ns
t_{DSW}	Data Setup Time	40	-	-	ns
t_{DHW}	Data Hold Time	10	-	-	ns
t_{ACC}	Data Access Time	-	-	140	ns
t_{OH}	Output Hold time	-	-	70	ns
t_R	Rise Time	-	-	15	ns
t_F	Fall Time	-	-	15	ns

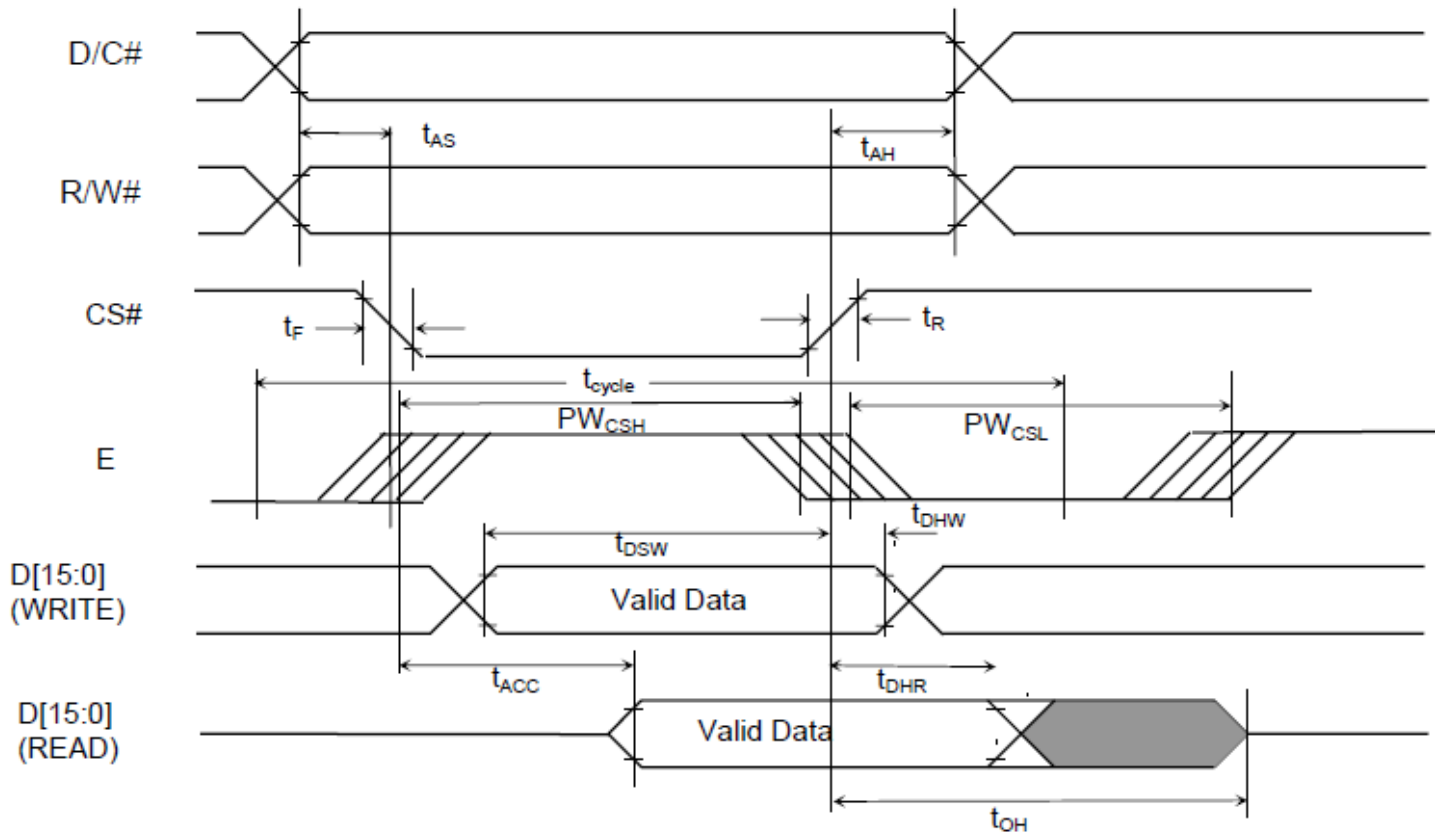

Parallel (8080 mode):

Symbol	Parameter	Min	Typ	Max	Unit
t_{cycle}	Clock Cycle Time	130	-	-	ns
t_{AS}	Address Setup Time	10	-	-	ns
t_{AH}	Address Hold Time	0	-	-	ns
t_{DSW}	Write Data Setup Time	40	-	-	ns
t_{DHW}	Write Data Hold Time	10	-	-	ns
t_{DHR}	Read Data Hold Time	20	-	-	ns
t_{OH}	Output Disable Time	-	-	70	ns
t_{ACC}	Access Time	-	-	140	ns
t_{PWLW}	Read Low Time	150	-	-	ns
t_{PWLW}	Write Low Time	60	-	-	ns
t_{PWHR}	Read High Time	60	-	-	ns
t_{PWHW}	Write High Time	60	-	-	ns
t_R	Rise Time	-	-	15	ns
t_F	Fall Time	-	-	15	ns
t_{CS}	Chip select setup time	0	-	-	ns
t_{CSH}	Chip select hold time to read signal	0	-	-	ns
t_{CSF}	Chip select hold time	20	-	-	ns

Write cycle (Form 1)

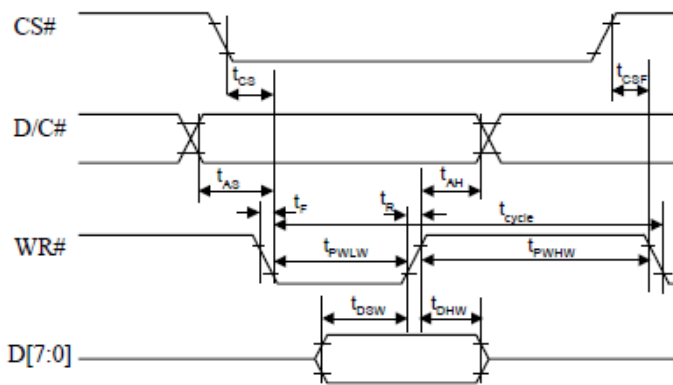

Read cycle (Form 1)

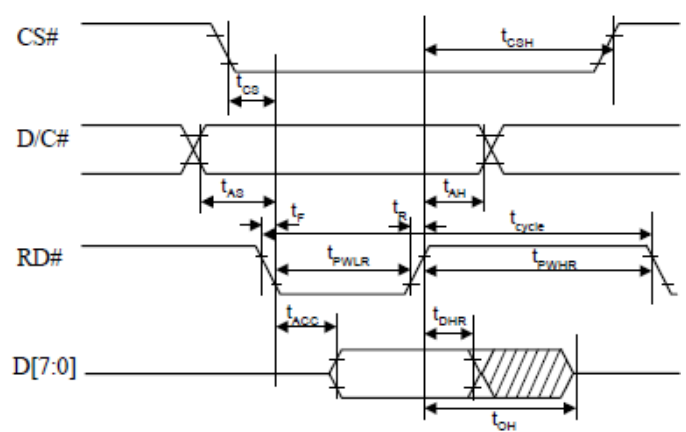

Write cycle (Form 2)

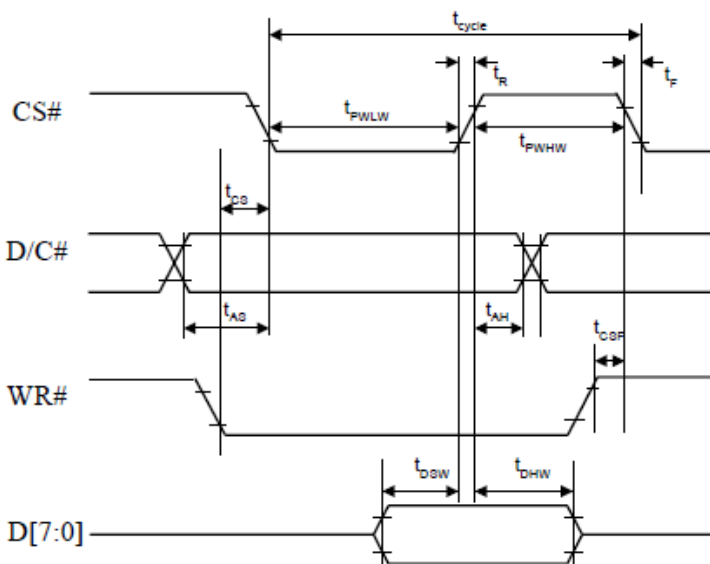

Read cycle (Form 2)

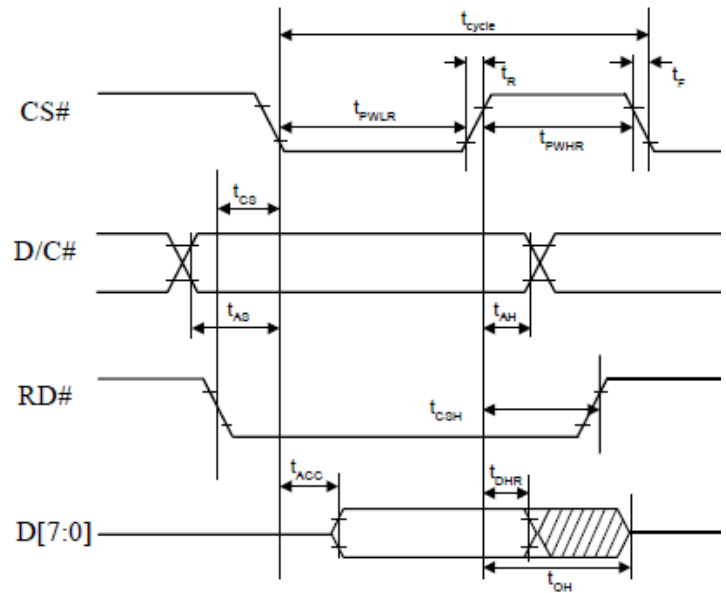

4-wire SPI:

Symbol	Parameter	Min	Typ	Max	Unit
t_{cycle}	Clock Cycle Time	150	-	-	ns
t_{AS}	Address Setup Time	40	-	-	ns
t_{AH}	Address Hold Time	40	-	-	ns
t_{CSS}	Chip Select Setup Time	75	-	-	ns
t_{CSH}	Chip Select Hold Time	60	-	-	ns
t_{OSW}	Write Data Setup Time	40	-	-	ns
t_{OHV}	Write Data Hold Time	40	-	-	ns
t_{CLKL}	Clock Low Time	75	-	-	ns
t_{CLKH}	Clock High Time	75	-	-	ns
t_R	Rise Time	-	-	15	ns
t_F	Fall Time	-	-	15	ns

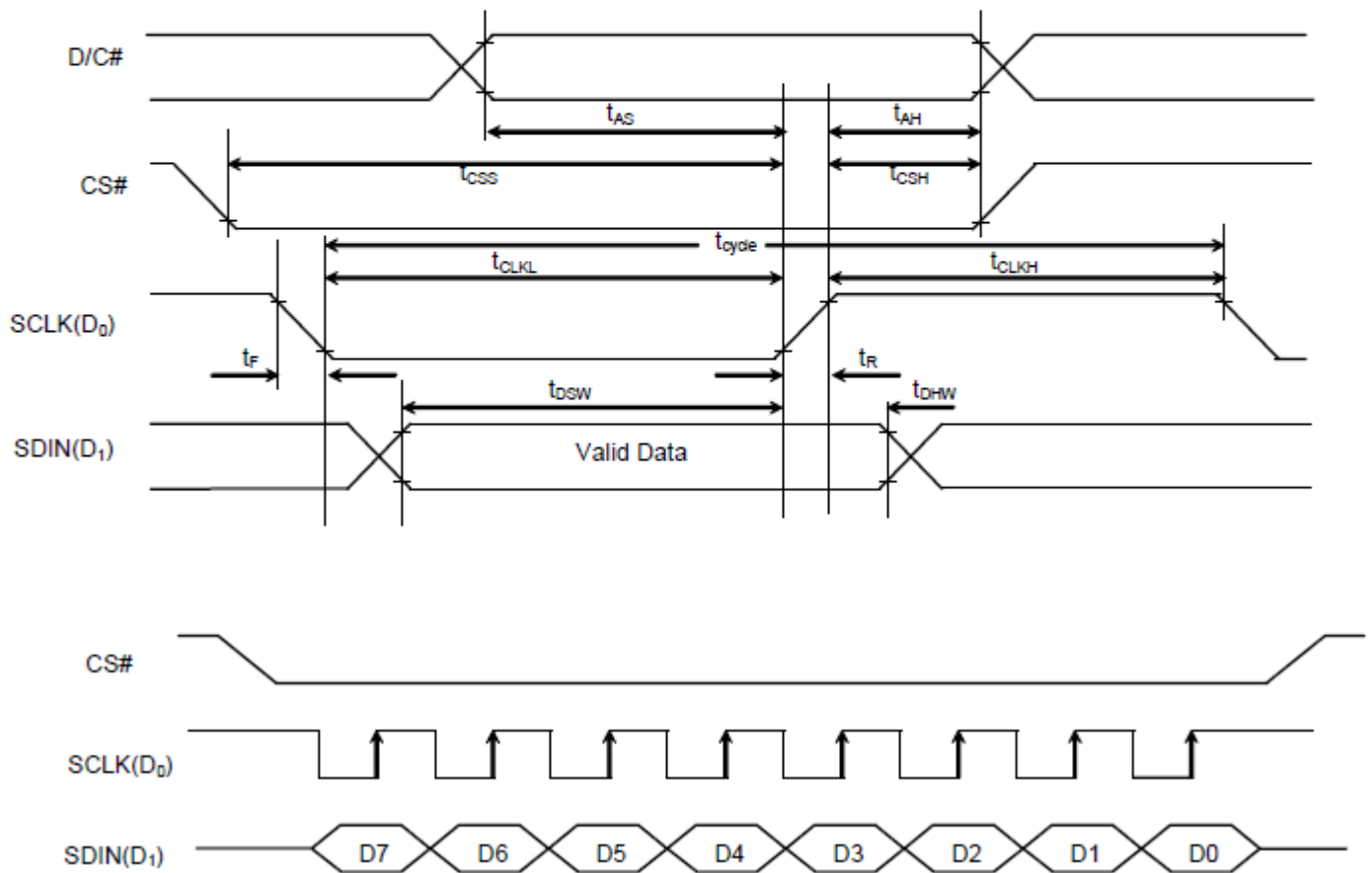

Example Initialization Sequence:

```
void OLED_Init_9664RGB(void)
{
  GPIO_ResetBits(RES_pin);
  delay_ms(300);
  GPIO_SetBits(RES_pin);
  delay_ms(10);

  oled_Command_9664RGB(0xFD); //Command Unlock
  oled_Command_9664RGB(0x12);

  oled_Command_9664RGB(0xAE); //Set Display OFF

  oled_Command_9664RGB(0xB3); //Set Display Clock Divide Ratio/Oscillator Frequency
  oled_Command_9664RGB(0xF0);

  oled_Command_9664RGB(0xA8); //Set MUX Ratio
  oled_Command_9664RGB(0x3F);

  oled_Command_9664RGB(0xA2); //Set Display Offset
  oled_Command_9664RGB(0x00);

  oled_Command_9664RGB(0xA1); //Set Display Start Line
  oled_Command_9664RGB(0x00);

  oled_Command_9664RGB(0xA0); //Set Re-map & Color Depth
  oled_Command_9664RGB(0x74);

  oled_Command_9664RGB(0xAD); //Set Master Configuration
  oled_Command_9664RGB(0x8E);

  oled_Command_9664RGB(0xB0); //Set Power Saving Mode
  oled_Command_9664RGB(0x0B);

  oled_Command_9664RGB(0xB1); //Set Contrast Current for A
  oled_Command_9664RGB(0x91);

  oled_Command_9664RGB(0xB2); //Set Contrast Current for B
  oled_Command_9664RGB(0x50);

  oled_Command_9664RGB(0xB3); //Set Contrast Current for C
  oled_Command_9664RGB(0x7D);

  oled_Command_9664RGB(0x87); //Master Current Control
  oled_Command_9664RGB(0x06);

  oled_Command_9664RGB(0xB1); //Set Phase Length
  oled_Command_9664RGB(0x31);

  oled_Command_9664RGB(0xBB); //Set Pre-charge Voltage
  oled_Command_9664RGB(0x3A);

  oled_Command_9664RGB(0x8A); //Set Second Pre-Charge Speed for Color A
  oled_Command_9664RGB(0x64);
```



```
oled_Command_9664RGB(0x8B); //Set Second Pre-Charge Speed for Color B
oled_Command_9664RGB(0x78);

oled_Command_9664RGB(0x8C); //Set Second Pre-Charge Speed for Color C
oled_Command_9664RGB(0x64);

oled_Command_9664RGB(0xBE); //Set VCOMH
oled_Command_9664RGB(0x3E);

oled_Command_9664RGB(0xA4); //Set Display Mode

oled_Clear_Screen();          //Clear Display

oled_Command_9664RGB(0xAF); //Set Display ON

delay_ms(100);
}
```

Quality Information

Test Item	Content of Test	Test Condition	Note
High Temperature storage	Test the endurance of the display at high storage temperature.	+85°C, 240 Hrs.	2
Low Temperature storage	Test the endurance of the display at low storage temperature.	-40°C, 240 Hrs.	1,2
High Temperature Operation	Test the endurance of the display by applying electric stress (voltage & current) at high temperature.	+70°C, 240 Hrs.	2
Low Temperature Operation	Test the endurance of the display by applying electric stress (voltage & current) at low temperature.	-40°C, 240 Hrs.	1,2
High Temperature / Humidity Operation	Test the endurance of the display by applying electric stress (voltage & current) at high temperature with high humidity.	+60°C, 90% RH, 120 Hrs.	1,2
Thermal Shock resistance	Test the endurance of the display by applying electric stress (voltage & current) during a cycle of low and high temperatures.	-40°C, 30 min -> 25°C, 5 min -> 70°C, 30 min = 1 cycle 100 Cycles	
Vibration test	Test the endurance of the display by applying vibration to simulate transportation and use.	10-22Hz , 15mm amplitude. 22-500Hz, 1.5G 30min in each of 3 directions X,Y,Z	3
Atmospheric Pressure test	Test the endurance of the display by applying atmospheric pressure to simulate transportation by air.	115mbar, 40hrs	3
Static electricity test	Test the endurance of the display by applying electric static discharge.	V _s =800V, R _s =1.5kΩ, C _s =100pF One time	

Note 1: No condensation to be observed.

Note 2: Conducted after 2 hours of storage at 25°C, 0%RH.

Note 3: Test performed on product itself, not inside a container.

Evaluation Criteria:

- 1: Display is fully functional during operational tests and after all tests, at room temperature.
- 2: No observable defects.
- 3: Luminance >50% of initial value.
- 4: Current consumption within 50% of initial value

Precautions for using OLEDs/LCDs/LCMs

See Precautions at www.newhavendisplay.com/specs/precautions.pdf

Warranty Information

See Terms & Conditions at http://www.newhavendisplay.com/index.php?main_page=terms

Компания «Life Electronics» занимается поставками электронных компонентов импортного и отечественного производства от производителей и со складов крупных дистрибьюторов Европы, Америки и Азии.

С конца 2013 года компания активно расширяет линейку поставок компонентов по направлению коаксиальный кабель, кварцевые генераторы и конденсаторы (керамические, пленочные, электролитические), за счёт заключения дистрибьюторских договоров

Мы предлагаем:

- Конкурентоспособные цены и скидки постоянным клиентам.
- Специальные условия для постоянных клиентов.
- Подбор аналогов.
- Поставку компонентов в любых объемах, удовлетворяющих вашим потребностям.
- Приемлемые сроки поставки, возможна ускоренная поставка.
- Доставку товара в любую точку России и стран СНГ.
- Комплексную поставку.
- Работу по проектам и поставку образцов.
- Формирование склада под заказчика.
- Сертификаты соответствия на поставляемую продукцию (по желанию клиента).
- Тестирование поставляемой продукции.
- Поставку компонентов, требующих военную и космическую приемку.
- Входной контроль качества.
- Наличие сертификата ISO.

В составе нашей компании организован Конструкторский отдел, призванный помогать разработчикам, и инженерам.

Конструкторский отдел помогает осуществить:

- Регистрацию проекта у производителя компонентов.
- Техническую поддержку проекта.
- Защиту от снятия компонента с производства.
- Оценку стоимости проекта по компонентам.
- Изготовление тестовой платы монтаж и пусконаладочные работы.



Тел: +7 (812) 336 43 04 (многоканальный)

Email: org@lifeelectronics.ru