

# 6325 PCI Express Card Edge Connectors

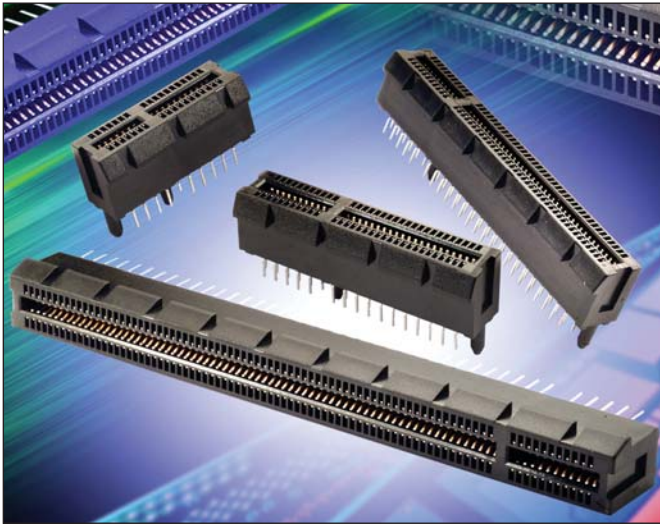

## GENERAL DESCRIPTION

The standard vertical card edge connectors are specifically designed to implement PCI Express technology for desktop PCs and server systems. These connectors allow the end user to upgrade the PC with an “add on graphics card”. Therefore complete range is available to support basic speed x1 to high-speed x16 bandwidth requirements.

The connectors are available in 36(x1), 64(x4), 98(x8) and 164(x16) contact positions, all in a 1.00mm pitch. Therefore each range can support different bandwidth requirements for an “add on” graphics card.

These connectors are ideal for use in a broad range of computing/data communication applications, including desktop PCs, Servers and Workstations.

All connectors support PCI Express signal and Power requirements as well as the interface between system board and the add on card specification.

## FEATURES/BENEFITS

- Different tail (contact) length (2.3mm or 3.00mm) available to support differing motherboard thickness.
- Tails are offset to form 4 rows on a 2.00mm pitch, thus making wave soldering easier.
- All connectors come with locating bosses to help align the connector to PCB (motherboard).
- Raised ridge at the topside of the connector, which can be used to lock/retain the graphic card.
- Molded polarization key prevents improper insertion of the PCB.
- Connectors have slots to accept “add in” cards with thickness of 1.58mm (0.062in).
- Conforms to PCI Express specification on connectors.
- Available in black or white color.

## TECNICAL SPECIFICATIONS

- Current Rating:** 1.1 Ampere, maximum
- Contact Resistance:** 30 milliohm, maximum
- Contact Material:** Phosphor Bronze
- Contact Plating:** See table below
- Insulator Material:** 30% Glass Filled Nylon
- Insulation Resistance:** 100 Megaohms 50 50V AC

Plating Table

Code	Contact Area	Terminal Area
6	15µ" AuNi (0.38µM)	Tin

## APPLICATIONS

- Desktop PCs
- Servers
- Work Stations
- Factory Automation Systems

## HOW TO ORDER

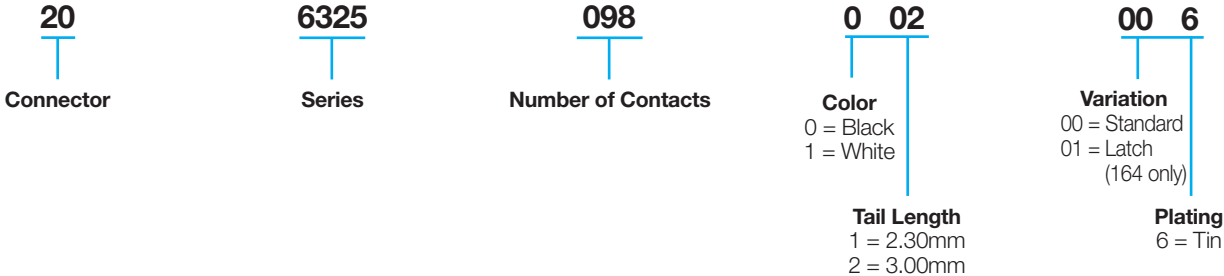

# 6325 PCI Express Card Edge Connectors



## 36 WAY CONNECTOR

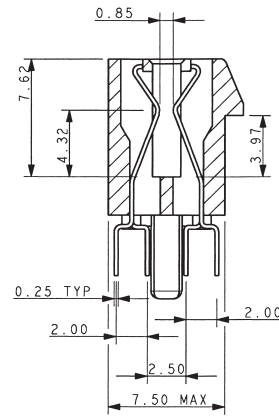
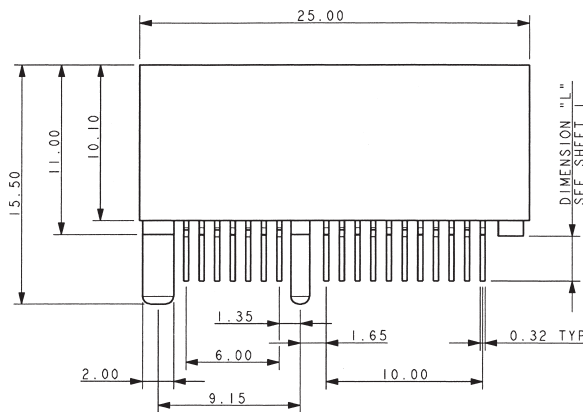
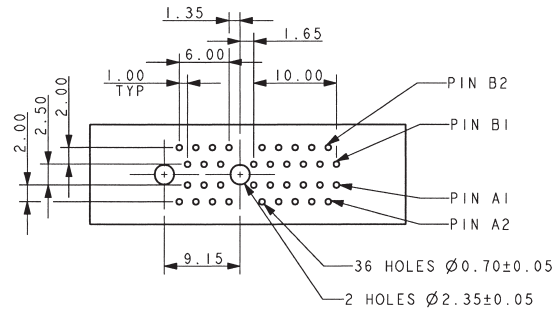
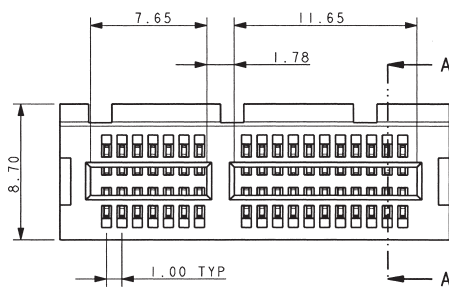

SECTION ON A-A

## 64 WAY CONNECTOR

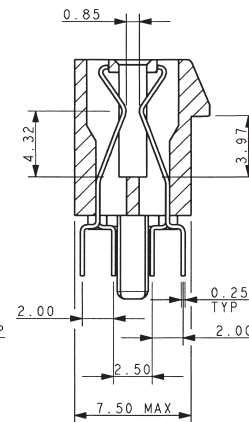
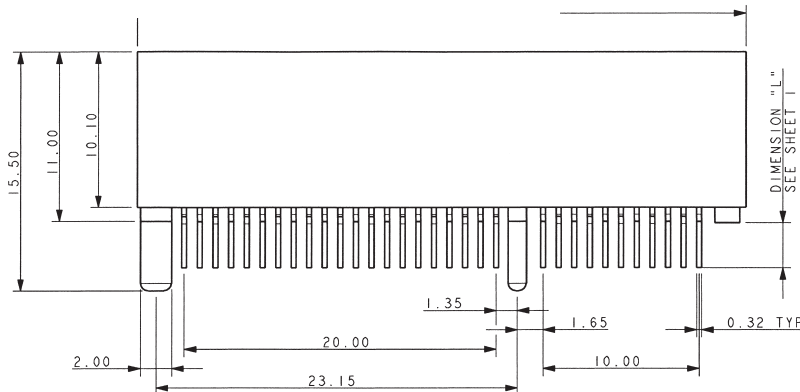
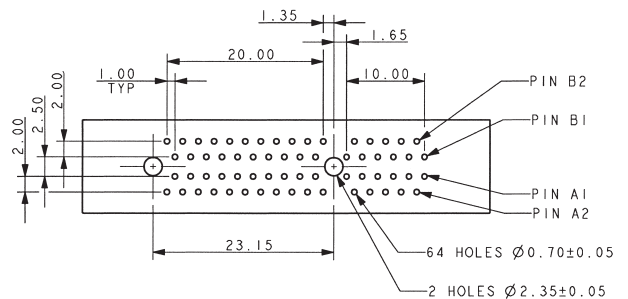
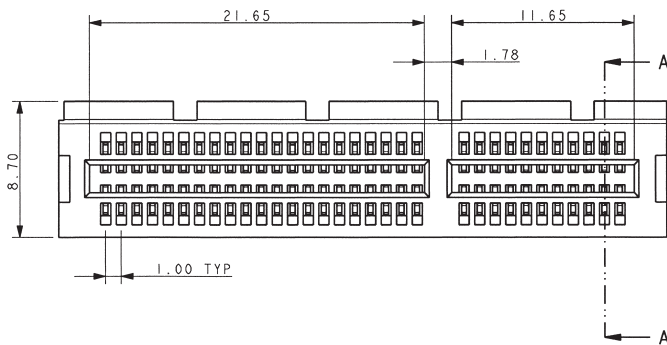

SECTION A-A



# 6325 PCI Express Card Edge Connectors



## 98 WAY CONNECTOR

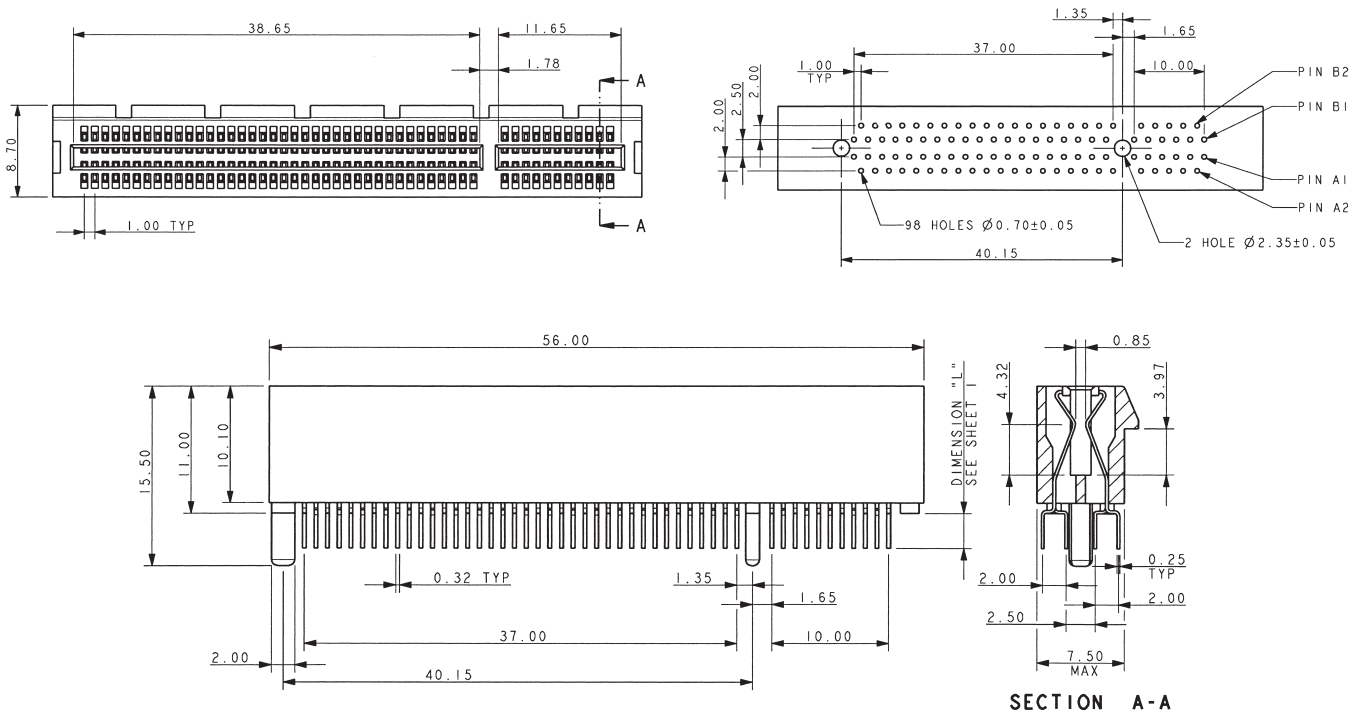

## 164 WAY CONNECTOR

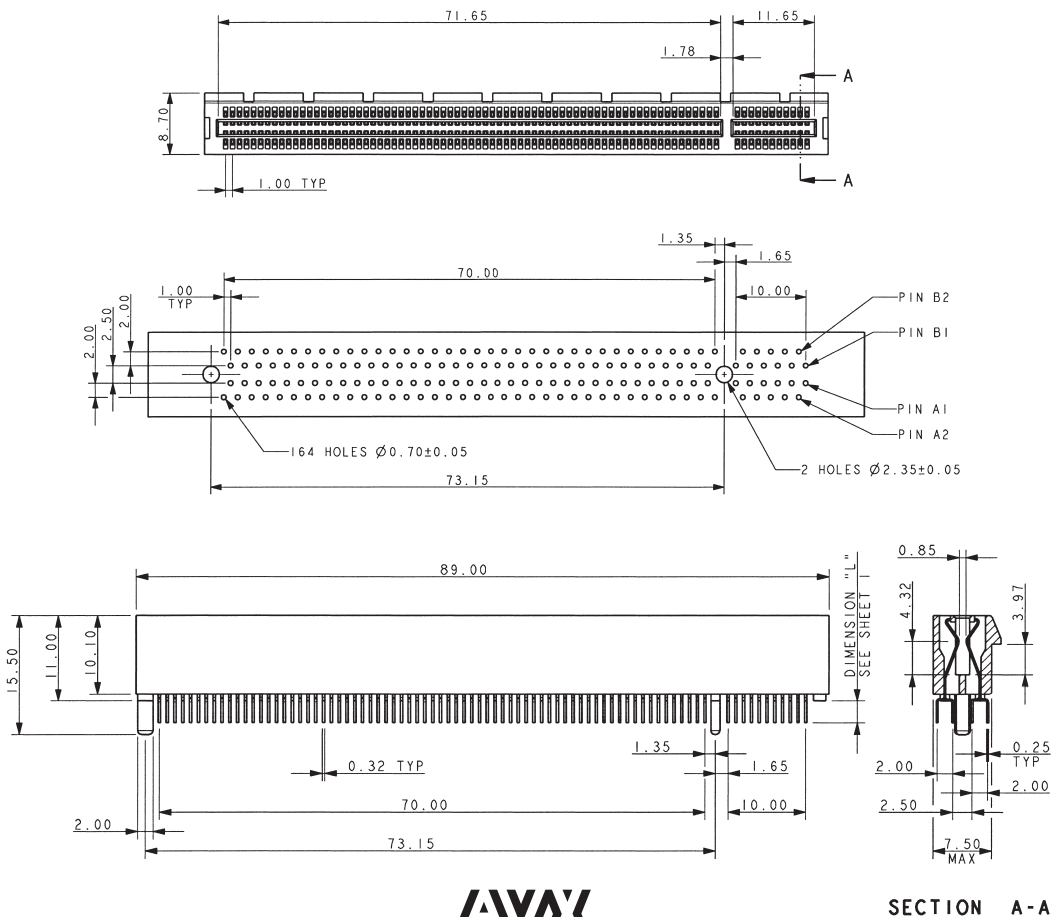

SECTION A-A

# 6325 PCI Express Card Edge Connectors



## 164 WAY CONNECTOR WITH LATCH

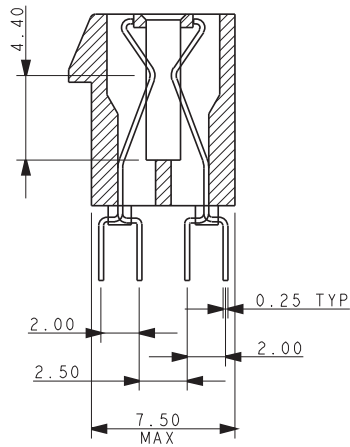
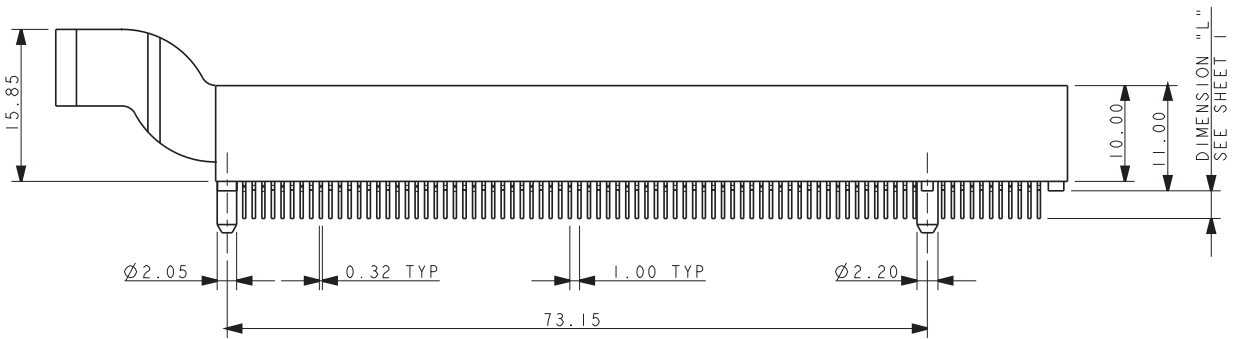
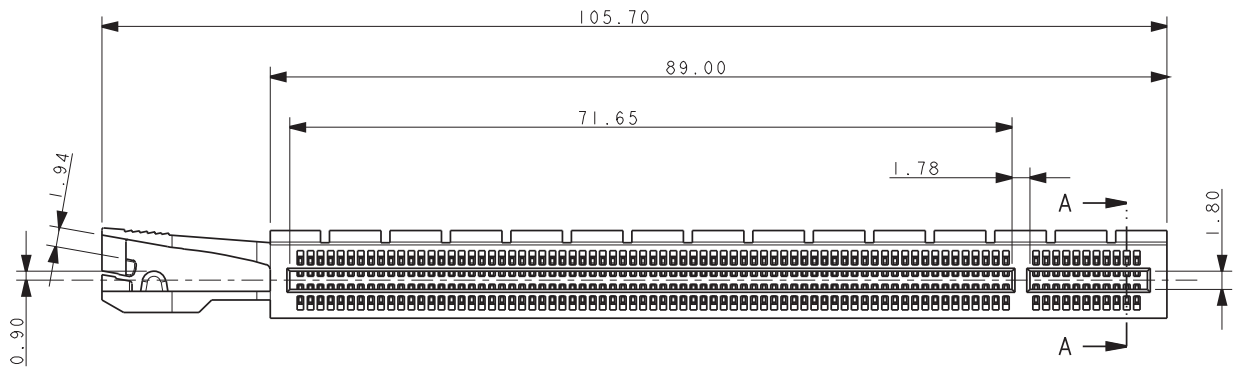

SECTION ON A-A



# 6325 PCI Express Card Edge Connectors



## SUGGESTED PCB LAYOUT - PCB EDGE 36 WAY CONNECTOR

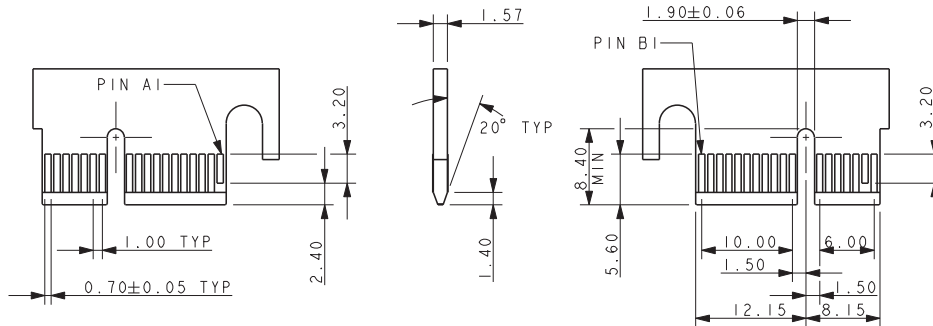

## 64 WAY CONNECTOR

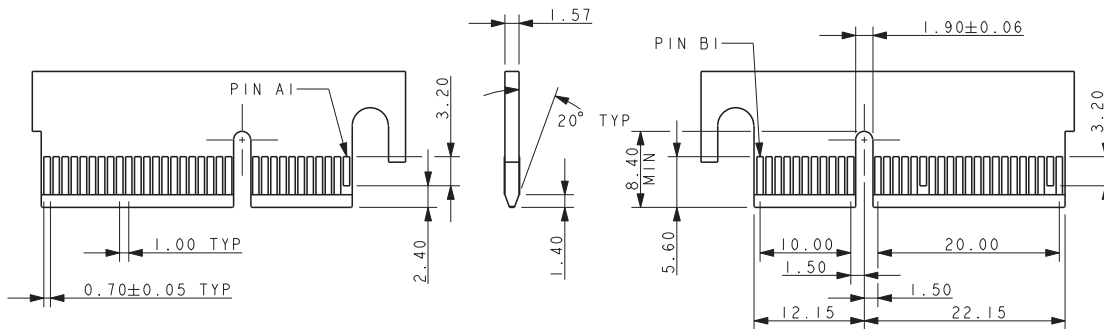

## 98 WAY CONNECTOR

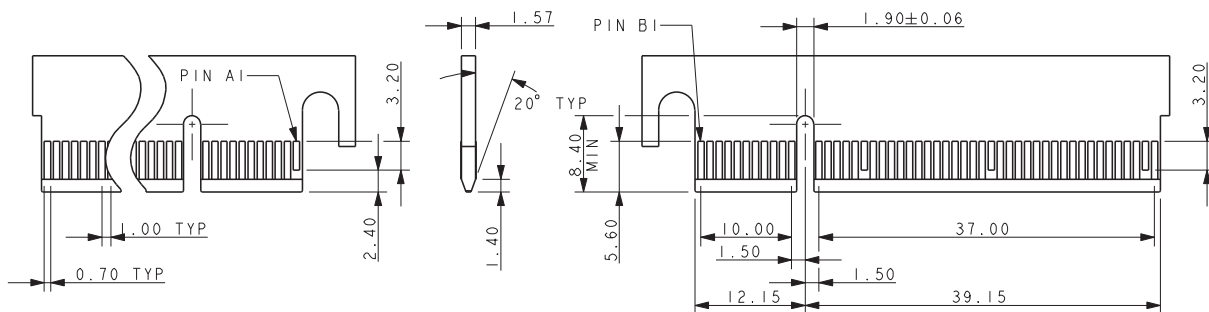

## 164 WAY CONNECTOR

(EDGE PROFILE OF PCB AS CENTER VIEW FOR 36 WAY CONNECTOR)

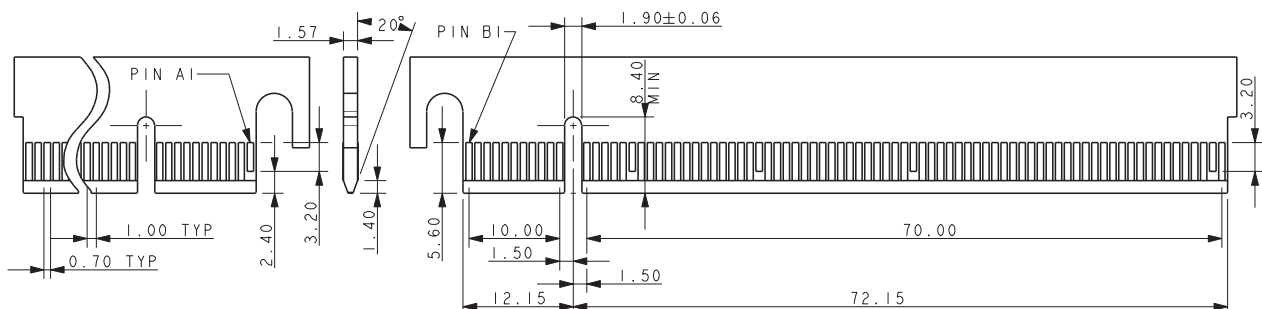

## AMERICAS

### AVX Myrtle Beach, SC Corporate Offices

Tel: 843-448-9411  
FAX: 843-448-1943

### AVX Northwest, WA

Tel: 360-699-8746  
FAX: 360-699-8751

### AVX North Central, IN

Tel: 317-848-7153  
FAX: 317-844-9314

### AVX Midwest, MN

Tel: 952-974-9155  
FAX: 952-974-9179

### AVX Mid/Pacific, CA

Tel: 510-661-4100  
FAX: 510-661-4101

### AVX Northeast, MA

Tel: 617-479-0345  
FAX: 843-916-7614

### AVX Southwest, AZ

Tel: 602-678-0384  
FAX: 602-678-0385

### AVX South Central, TX

Tel: 214-566-2859  
FAX: 972-461-0575

### AVX Southeast, GA

Tel: 404-608-8151  
FAX: 770-972-0766

### AVX Canada

Tel: 905-238-3151  
FAX: 905-238-0319

### AVX South America

Tel: ++55-11-2193-7200  
FAX: ++55-11-2193-7210

## EUROPE

### AVX Limited, England European Headquarters

Tel: ++44 (0) 1252-770000  
FAX: ++44 (0) 1252-770001

### AVX/ELCO, England

Tel: ++44 (0) 1638-675000  
FAX: ++44 (0) 1638-675002

### AVX S.A.S., France

Tel: ++33 (0) 1-69-18-46-00  
FAX: ++33 (0) 1-69-28-73-87

### AVX GmbH, Germany

Tel: ++49 (0) 8131-9004-0  
FAX: ++49 (0) 8131-9004-44

### AVX srl, Italy

Tel: ++390 (0)2 614-571  
FAX: ++390 (0)2 614-2576

### AVX Czech Republic

Tel: ++420 57 57 57 521  
FAX: ++420 57 57 57 109

## ASIA-PACIFIC

### AVX/Kyocera, Singapore Asia-Pacific Headquarters

Tel: (65) 6286-7555  
FAX: (65) 6488-9880

### AVX/Kyocera, Hong Kong

Tel: (852) 2-363-3303  
FAX: (852) 2-765-8185

### AVX/Kyocera, Korea

Tel: (82) 2-785-6504  
FAX: (82) 2-784-5411

### AVX/Kyocera, Taiwan

Tel: (886) 2-2698-8778  
FAX: (886) 2-2698-8777

### AVX/Kyocera, Malaysia

Tel: (60) 4-228-1190  
FAX: (60) 4-228-1196

### Elco, Japan

Tel: 045-943-2906/7  
FAX: 045-943-2910

### Kyocera, Japan - AVX

Tel: (81) 75-604-3426  
FAX: (81) 75-604-3425

### Kyocera, Japan - KDP

Tel: (81) 75-604-3424  
FAX: (81) 75-604-3425

### AVX/Kyocera, Shanghai, China

Tel: 86-21 6215 5588  
FAX: 86-21 6215 5580

### AVX/Kyocera, Beijing, China

Tel: 86-10 6588 3528  
Fax: 86-10 6588 3529

### AVX/Kyocera, Tianjin, China

Tel: 86-22 8558 9052  
Fax: 86-22 5885 9061

## ASIA-KED

### KED, Hong Kong

Tel: (852) 2305 1080  
FAX: (852) 2305 1405

### KED, Shanghai

Tel: (86) 21 6859 9898  
FAX: (86) 21 5887 2542

### KED, Beijing

Tel: (86) 10 5869 4655  
FAX: (86) 10 5869 4677

### KED, South Korea

Tel: (82) 2 783 3288  
FAX: (82) 2 783 3207

### KED, Taiwan

Tel: (886) 2 2950 0268  
FAX: (886) 2 2950 0520

### KED, Singapore

Tel: (65) 6255 3122  
FAX: (65) 6255 5092

## Contact:

NOTICE: Specifications are subject to change without notice. Contact your nearest AVX Sales Office for the latest specifications. All statements, information and data given herein are believed to be accurate and reliable, but are presented without guarantee, warranty, or responsibility of any kind, expressed or implied. Statements or suggestions concerning possible use of our products are made without representation or warranty that any such use is free of patent infringement and are not recommendations to infringe any patent. The user should not assume that all safety measures are indicated or that other measures may not be required. Specifications are typical and may not apply to all applications.

© AVX Corporation



<http://www.avx.com>

S-MCC00M208-C

Компания «Life Electronics» занимается поставками электронных компонентов импортного и отечественного производства от производителей и со складов крупных дистрибьюторов Европы, Америки и Азии.

С конца 2013 года компания активно расширяет линейку поставок компонентов по направлению коаксиальный кабель, кварцевые генераторы и конденсаторы (керамические, пленочные, электролитические), за счёт заключения дистрибьюторских договоров

Мы предлагаем:

- Конкурентоспособные цены и скидки постоянным клиентам.
- Специальные условия для постоянных клиентов.
- Подбор аналогов.
- Поставку компонентов в любых объемах, удовлетворяющих вашим потребностям.
- Приемлемые сроки поставки, возможна ускоренная поставка.
- Доставку товара в любую точку России и стран СНГ.
- Комплексную поставку.
- Работу по проектам и поставку образцов.
- Формирование склада под заказчика.
- Сертификаты соответствия на поставляемую продукцию (по желанию клиента).
- Тестирование поставляемой продукции.
- Поставку компонентов, требующих военную и космическую приемку.
- Входной контроль качества.
- Наличие сертификата ISO.

В составе нашей компании организован Конструкторский отдел, призванный помогать разработчикам, и инженерам.

Конструкторский отдел помогает осуществить:

- Регистрацию проекта у производителя компонентов.
- Техническую поддержку проекта.
- Защиту от снятия компонента с производства.
- Оценку стоимости проекта по компонентам.
- Изготовление тестовой платы монтаж и пусконаладочные работы.



Тел: +7 (812) 336 43 04 (многоканальный)

Email: [org@lifeelectronics.ru](mailto:org@lifeelectronics.ru)