

No.131211

承 認 書  
(SPECIFICATION FOR APPROVAL)

CUSTOMER : 肯創

MODEL : IG220019X00015R

DATE : Dec 13, 2013

SUPPLIER :



CUSTOMER :

肯創科技·許江海



祥儀企業股份有限公司  
SHAYANG YE INDUSTRIAL CO.,LTD.

桃園縣桃園市桃鶯路 461 號  
TEL:(03)3623452  
FAX:(03)3628404  
<http://www.shayye.com.tw>

NO.461,Taoying Rd.,Taoyuan City,  
Taoyuan County,Taiwan R.O.C.

E-MAIL:sales@shayye.com.tw

# Technical Data

<b>Part Number</b>	IG220019X00015R	
<b>Customer P/N</b>		
<b>ITEM</b>	<b>Specifications</b>	<b>Note</b>
<b>1. Operation Status</b> 1.1 Rated Voltage 1.2 Rated torque 1.3 Radial load 1.4 Axial load 1.5 Turning direction 1.6 Reverse direction 1.7 Using environment 1.8 Preserve environment 1.9 Using voltage range	12V D.C. 0.3 kgf.cm 8N (0.8kg-f) 6N (0.6kg-f) Shaft horizontal CW.CCW Temperature -10~60 °C Humidity 20~90% RH Temperature -20~70 °C Humidity 20~90% RH 12V (D.C.) ±10%	Stable power source 6mm from shaft end
<b>2. Electrical Characteristics</b> 2.1 No Load current 2.2 No Load speed 2.3 Rated current 2.4 Rated speed 2.5 Stall current 2.6 Stall torque 2.7 Insulation 2.8 Durable voltage 2.9 Coil resistance 2.10 Torque constant 2.11 Voltage constant	200 mA max. 789 rpm ±15% 620 mA 639 rpm ±15% 2.4 A 2.2 kgf.cm D.C. 100V meg. 1.0 MΩ min 100V (A.C.) , 1 minute min 5Ω 0.91 kgf.cm/A 8.68 mV/r/min	Motor terminal shell Motor terminal shell Reference Reference Reference
<b>3. Mechanical characteristic</b> 3.1 Reduction ratio 3.2 Thrust play of shaft 3.3 Radial play of shaft 3.4 Back lash 3.5 Outside Appearance	1/19.225 0.2 mm max. 0.05 mm max. 3° max. No scratch defective...	By visual judgment
<b>2. Life Cycle</b>	72000 cycles min.  	After the rated life cycle test current @ rated load must stay within ±30% of the initial value and r.p.m. @ rated load must stay within ±20% of the initial value. However change of mechanical noise level was not considered as part of the testing

# **ASSEMBLY, MAINTENANCE, OPERATION**

1. Install: To avoid internal geared motor touched by overlong screws and caused defective. Please check screw size and length on external dimension drawing when installing geared motor into construction.
2. Reprocess: Heavy impact and vibration during reprocessing output shaft may cause loose screws and lead to unbalance gear operation. Please avoid reprocessing output shaft.  
Must to prevent overheat when weld wires into terminal and cause breakdown due to burnt internal geared motor parts.  
Please do not overload the radial load limitation of output shaft when using belt pulley or chain pulley as power transmission. Please do not overload the axial load limitation of output shaft when pressing parts upon it as well.
3. Environment: The parts of geared motors or itself may corroded or damaged easier when using or maintaining in out of range environment. Must to pay close attention that gears may corroded even under an allowed environment in long term.
4. Impact: Must prevent geared motor from falling and impact, or the parts will get damaged, the screws will be loosed, and the gear operation will unbalance etc...
5. Locked out: Please well prepared current transmitting protection in case of burnt motor coil easy and damaged gear from locked out geared motor.
6. Output shaft Turning:  
Please note that it is easier to damage gear when directly turning output shaft.
7. PWM controlling:  
The graphite brush of motor will be abnormally wore out or the commutator interval will be blocked by carbon powder when using in the condition of D/T under 60%.  
Moreover, please pay attention to the motor with capacitor due to there is ineffectual capacity cycle scope.
8. Momentary reverse:  
The graphite brush will be abnormally wore out or coil getting aggravated when geared motor is reversed momentary.  
Also, the commutator interval will be stuck if switch frequently.

# SHAYANG YE INDUSTRIAL CO.,LTD.

Mode: IG220019X00015R

S/N: 001

Voltage : 12 V

Date: 20131213

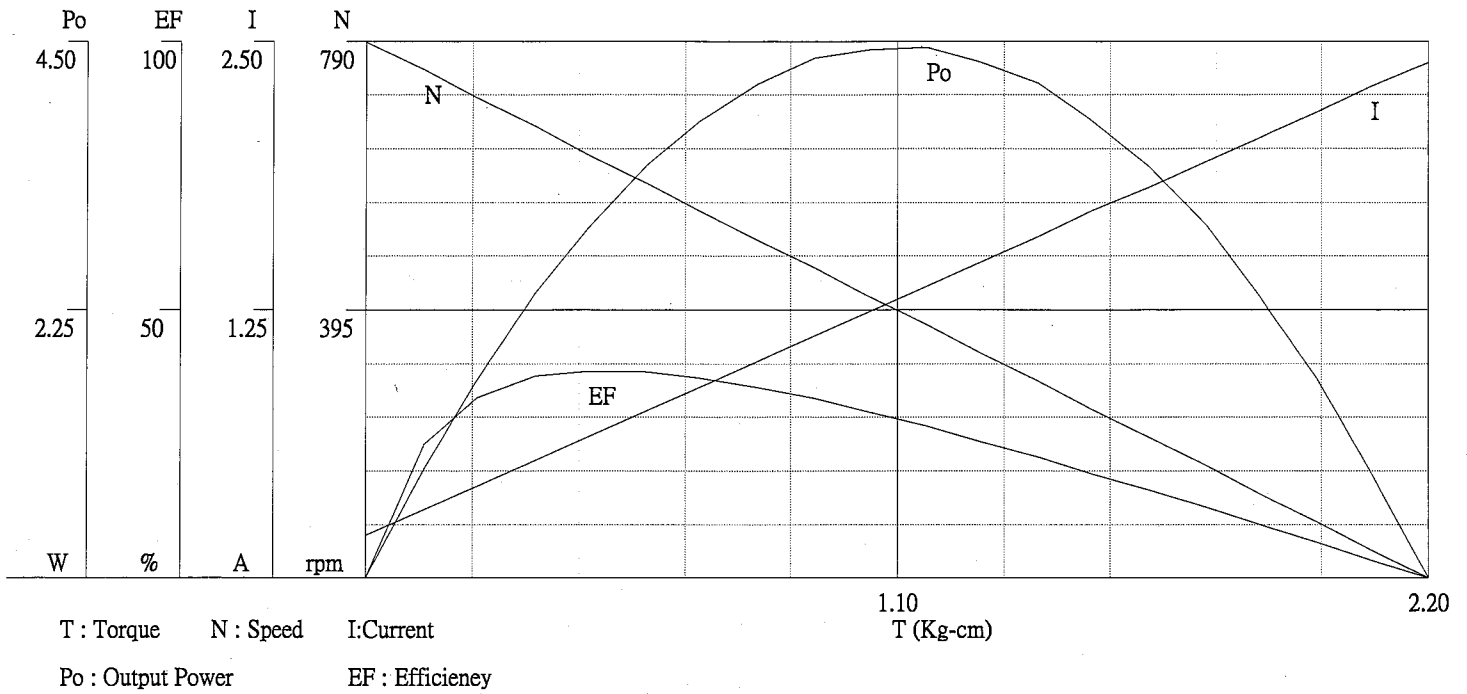

	T(N/m)	[Kg/cm]	N(rpm)	I(A)	Po(W)	EF(%)
No Load	0	0.00	789.00	.20	0	0
	.01	.12	748.21	.32	.92	25
	.03	.35	664.99	.55	2.39	37.73
	.06	.58	581.51	.78	3.46	38.49
	.07	.69	540.29	.89	3.83	37.32
	.08	.81	498.15	1.01	4.14	35.59
	.09	.93	457.23	1.13	4.36	33.55
	.1	1.04	415.47	1.24	4.43	31.05
	.12	1.27	332.34	1.47	4.33	25.56
	.14	1.39	290.84	1.59	4.15	22.65
	.15	1.50	249.35	1.71	3.84	19.5
	.16	1.62	207.75	1.82	3.45	16.48
	.17	1.74	165.96	1.94	2.96	13.25
	.18	1.85	124.67	2.05	2.37	10.03
	.2	2.08	41.56	2.29	.89	3.36
Stall	.22	2.20	0.00	2.40	0	0
Po...(max)	.11	1.16	373.66	1.36	4.45	28.37
EF...(max)	.05	.46	622.40	.66	2.94	38.62

參考 REF.  
 估價 EVALUATE  
 試作 INITIAL  
 製作 MASS

Two Channel Encoder  
 Connections :  
  
 JST PHR-6  
 P=2.0-6P  
 2. Red : -MOTOR  
 3. Brown : +MOTOR  
 4. Green : HALL SENSOR Vcc  
 5. Blue : HALL SENSOR GND  
 6. Purple : HALL SENSOR A Vout  
 7. Purple : HALL SENSOR B Vout

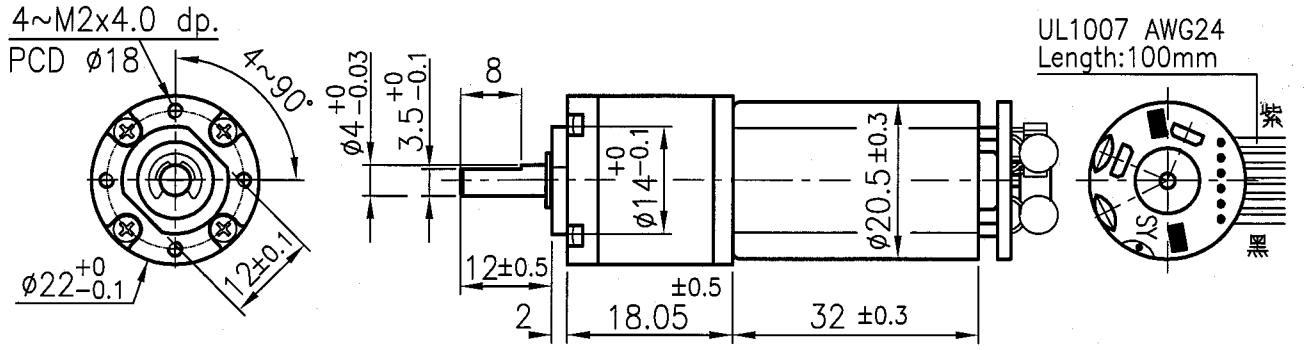

REDUCTION RATIO: 1/19.22  
 OUTPUT SHAFT: STEEL  
 MOTOR SPECIFICATION: 12V 15000RPM  
 OUTPUT-789RPM/  $\leq 200\text{mA}$  WITH NO LOAD

核准 APPROVED BY  
 核對 CHECKED BY  
 繪圖 DRAWIN BY

軸徑 $-0$	孔徑 $+0$	長度, 角度 $\pm$									
— 指定等級區分之數值公差											
區分	1~6	6~18	18~50	50~120	120~250	250~500	500~1000	角度			
等級	1級	0.1	0.2	0.3	0.4	0.5	0.6	0.8	1°		
	2級	0.2	0.4	0.6	0.8	1.2	1.6	2.0	2°		
未標示孔徑距公差			±0.1		±0.2						
熱處理 HEAT TREATMENT				件名 PART NAME	GEARMOTOR				單位 UNITS	mm	
表面處理 SURFACE				圖號 DWG.	IG220019X00015R				比例 SCALE	9/10	
材質 MATERIAL				 祥儀企業股份有限公司 SHA YANG YE INDUSTRIAL CO., LTD.							
重量 WEIGHT			頁次 SHEET							1/1	

1	新出圖								
設變單號 E.C.N.				設變單號 E.C.N.					

IG22

Компания «Life Electronics» занимается поставками электронных компонентов импортного и отечественного производства от производителей и со складов крупных дистрибьюторов Европы, Америки и Азии.

С конца 2013 года компания активно расширяет линейку поставок компонентов по направлению коаксиальный кабель, кварцевые генераторы и конденсаторы (керамические, пленочные, электролитические), за счёт заключения дистрибьюторских договоров

Мы предлагаем:

- Конкурентоспособные цены и скидки постоянным клиентам.
- Специальные условия для постоянных клиентов.
- Подбор аналогов.
- Поставку компонентов в любых объемах, удовлетворяющих вашим потребностям.
- Приемлемые сроки поставки, возможна ускоренная поставка.
- Доставку товара в любую точку России и стран СНГ.
- Комплексную поставку.
- Работу по проектам и поставку образцов.
- Формирование склада под заказчика.
- Сертификаты соответствия на поставляемую продукцию (по желанию клиента).
- Тестирование поставляемой продукции.
- Поставку компонентов, требующих военную и космическую приемку.
- Входной контроль качества.
- Наличие сертификата ISO.

В составе нашей компании организован Конструкторский отдел, призванный помогать разработчикам, и инженерам.

Конструкторский отдел помогает осуществить:

- Регистрацию проекта у производителя компонентов.
- Техническую поддержку проекта.
- Защиту от снятия компонента с производства.
- Оценку стоимости проекта по компонентам.
- Изготовление тестовой платы монтаж и пусконаладочные работы.



Тел: +7 (812) 336 43 04 (многоканальный)  
Email: [org@lifeelectronics.ru](mailto:org@lifeelectronics.ru)