

### NEW! PAN1721 SERIES **BLUETOOTH**<sup>®</sup> LOW ENERGY

#### Ultra Low Power, *Bluetooth* Low Energy Module

Introducing the **PAN1721**, a complete power optimized *Bluetooth* v4.0 Low Energy (BLE) solution, this module includes an embedded processor, antenna and BLE stack. The **PAN1721** is engineered for ultra low power consumption applications.

The **PAN1721** is a cost-effective, ultra low-power, system-on-chip (SoC) for *Bluetooth* Low Energy applications. The module includes an eight channel, twelve bit analog-to-digital converter, 19 GPIOs plus battery and temperature sensors. A single device for both BLE master or slave nodes. The **PAN1721** combines an excellent RF transceiver with a high performance low power 8051 microcontroller, in-system programmable flash memory, 8-KB RAM, and many other powerful supporting features and peripherals.

The **PAN1721** is an ideal choice for applications where battery life is a critical application requirement, using only 500 nA in sleep mode. Short transition times between operating modes—3 uS Wake-Up – and power efficient hardware further reduce current consumption.

Panasonic offers *Bluetooth* Low Energy protocol stacks and applications from Texas Instruments and *BlueRadios*<sup>™</sup>. The *BlueRadios* stack enables rapid and low cost development using an AT command set without the need for a compiler. Additional advantages include UART programming, over-the-air-updates, easy integration “C” library framework, serial streaming of data, and smart phone libraries and applications.

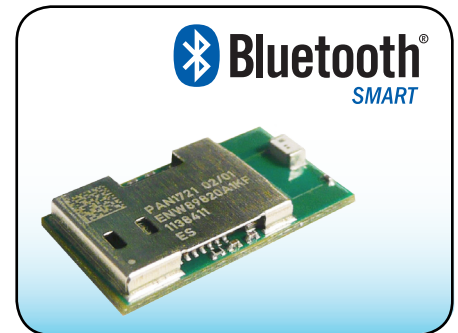

#### Product Performance:

- *Bluetooth* 4.0 Compliant and *Bluetooth* Low Energy
- Dimensions: 14.5x 8.2 x 3 mm
- Supports User Developed Applications
- Texas Instruments' Stack or Optional *BlueRadios* Stack
- 256K Flash, 8K RAM
- Supports 1 Mbps Data Rate
- Temperature Range -40°C to +85°C
- Eight Channel 12-Bit ADC
- 19 GPIOs
- Battery Monitor and Temperature Sensor

#### PAN1721/1711 Part Numbers:

Part Numbers	Description
ENW-89835A1KF	PAN1721, CC2541 <i>Bluetooth</i> Low Energy with 8051 Controller, Texas Instruments Stack
ENW-89835A3KF	PAN1721, CC2541 <i>Bluetooth</i> Low Energy with 8051 Controller, <i>BlueRadios</i> Stack
ENW-89835C1KF	PAN1711, CC2541 <i>Bluetooth</i> Low Energy with 8051 Controller, Texas Instruments Stack
ENW-89835C3KF	PAN1711, CC2541 <i>Bluetooth</i> Low Energy with 8051 Controller, <i>BlueRadios</i> Stack
EVAL_PAN1721	<i>Bluetooth</i> , PAN1721, Evaluation Kit, Includes Two PAN1721 USB Development Modules
EVAL_PAN1721BR	<i>Bluetooth</i> , PAN1721, Evaluation Kit, Includes Two PAN1721 USB Development Modules, <i>BlueRadios</i> FW

#### Alternative Low Energy Device:

Part Numbers	Description
ENW-89823A2JF	PAN1326, CC2564, <i>Bluetooth</i> & <i>Bluetooth</i> Low Energy, HCI Module, Antenna

The *Bluetooth*<sup>®</sup> word mark and logos are registered trademarks owned by Bluetooth SIG, Inc. and any use of such marks by Panasonic Corporation of North America is under license. Other trademarks and trade names are those of their respective owners.



### Interfaces:

The PAN1721 Interface supports:

- Two Powerful USARTs with Support for Several Serial Protocols
- I2C Interface
- 19 General-Purpose I/O Pins (17x4mA, 2x20mA)
- 12-Bit ADC with Eight Channels and Configurable Resolution

### Applications:

- 2.4 GHz *Bluetooth* Low Energy Systems
- Proprietary 2.4 GHz Systems
- Human Interface Devices
- Sports and Leisure Equipment
- Mobile Phone Accessories
- Consumer Electronics
- USB Dongles
- Health Care and Medical

### Block Diagram PAN1721/PAN1711:

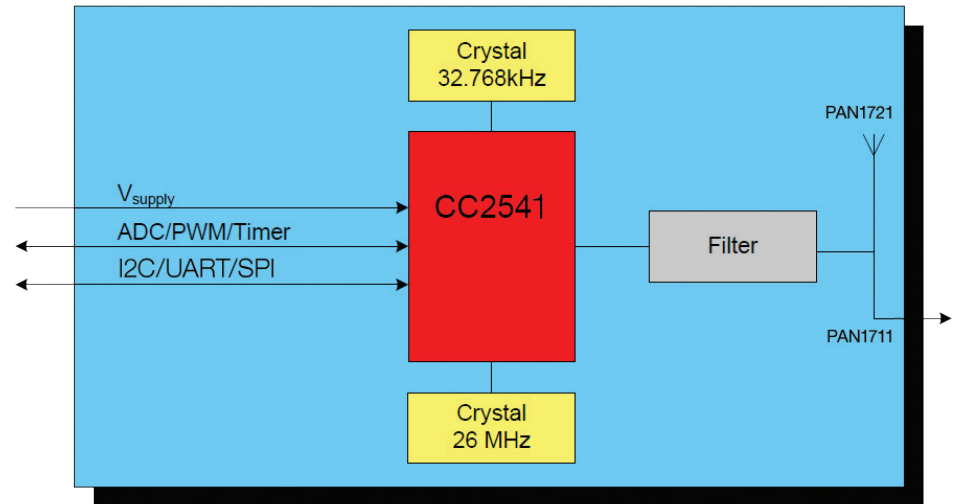

### Evaluation Kits:

#### EVAL\_PAN1721

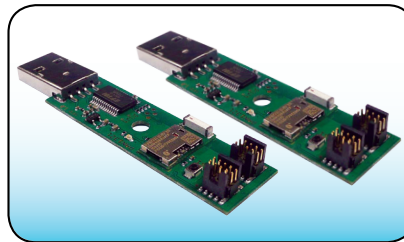

#### EVAL\_PAN1721BR



### Technical Specifications for PAN1721:

Parameter	Value	Condition / Notes
Receiver Sensitivity (1% PER)	-96 dBm	@ 500 kbps / MSK (High-Gain Mode)
Output Power	0 dBm typ.	Maximum Setting
Power Supply	2.0 - 3.6 V	Single Operation Voltage
Sleep Mode	0.5 $\mu$ A	Power Mode 3 (Lowest)
Transmit Mode	14 mA	@ 0dBm (Peak Current)
Receive Mode	14.7 mA	Standard Mode
Operating Temperature Range	-40°C to +85°C	Industrial Range

The *Bluetooth*® word mark and logos are registered trademarks owned by Bluetooth SIG, Inc. and any use of such marks by Panasonic Corporation of North America is under license. Other trademarks and trade names are those of their respective owners.



Компания «Life Electronics» занимается поставками электронных компонентов импортного и отечественного производства от производителей и со складов крупных дистрибьюторов Европы, Америки и Азии.

С конца 2013 года компания активно расширяет линейку поставок компонентов по направлению коаксиальный кабель, кварцевые генераторы и конденсаторы (керамические, пленочные, электролитические), за счёт заключения дистрибьюторских договоров

Мы предлагаем:

- Конкурентоспособные цены и скидки постоянным клиентам.
- Специальные условия для постоянных клиентов.
- Подбор аналогов.
- Поставку компонентов в любых объемах, удовлетворяющих вашим потребностям.
- Приемлемые сроки поставки, возможна ускоренная поставка.
- Доставку товара в любую точку России и стран СНГ.
- Комплексную поставку.
- Работу по проектам и поставку образцов.
- Формирование склада под заказчика.
- Сертификаты соответствия на поставляемую продукцию (по желанию клиента).
- Тестирование поставляемой продукции.
- Поставку компонентов, требующих военную и космическую приемку.
- Входной контроль качества.
- Наличие сертификата ISO.

В составе нашей компании организован Конструкторский отдел, призванный помогать разработчикам, и инженерам.

Конструкторский отдел помогает осуществить:

- Регистрацию проекта у производителя компонентов.
- Техническую поддержку проекта.
- Защиту от снятия компонента с производства.
- Оценку стоимости проекта по компонентам.
- Изготовление тестовой платы монтаж и пусконаладочные работы.



Тел: +7 (812) 336 43 04 (многоканальный)

Email: [org@lifeelectronics.ru](mailto:org@lifeelectronics.ru)