

PLEASE CHECK WWW.MOLEX.COM FOR LATEST PART INFORMATION

Part Number: [0877159911](#)
Status: **Active**
Overview:
Description: 1.00mm (.039") Pitch, PCI Express* Connector, 98 Circuits, Nylon 4/6 Glass-filled, Black Housing, Copper Alloy, 0.76µm (30µ") Gold (Au) Plating, with Beveled Metal Pins, 3.00mm (.118") Solder-tail, Lead Free

Agency Certification

CSA LR19980
 UL E29179

General

Product Family Edge Card Connectors
 Series 87715
 Comments PCI 8 lanes
 Component Type Edgecard to PCB
 Overview pci_express_card_edge_connector
 Product Name PCI Express*

Physical

Circuits (Loaded) 98
 Circuits (maximum) 98
 Circuits Detail All Signal
 Durability (mating cycles max) 50
 Entry Angle Vertical (Top Entry)
 Flammability 94V-0
 Keying to Mating Part Yes
 Material - Plating Mating Gold
 Material - Plating Termination Tin
 PC Tail Length (in) 0.118 In
 PC Tail Length (mm) 3.00 mm
 PCB Locator Yes
 PCB Retention Yes
 PCB Thickness Recommended (in) 0.093 In
 PCB Thickness Recommended (mm) 2.40 mm
 Packaging Type Tray
 Pitch - Mating Interface (in) 0.039 In
 Pitch - Mating Interface (mm) 1.00 mm
 Pitch - Term. Interface (in) 0.039 In
 Pitch - Term. Interface (mm) 1.00 mm
 Plating min: Mating (µin) 30
 Plating min: Mating (µm) 0.76
 Plating min: Termination (µin) 100
 Plating min: Termination (µm) 2.50
 Polarized to Mating Part Yes
 Temperature Range - Operating -55°C to +85°C
 Termination Interface: Style Through Hole

Electrical

Current - Maximum per Contact 1.1A
 Voltage - Maximum 50V AC (RMS)/DC

Material Info

Reference - Drawing Numbers

Packaging Specification PK-87715-204
 Product Specification PS-87715-200

EU RoHS

ELV and RoHS Compliant

REACH SVHC

Not Reviewed

Halogen-Free

Status

Not Reviewed

China RoHS



Need more information on product environmental compliance?

Email productcompliance@molex.com
 For a multiple part number RoHS Certificate of Compliance, [click here](#)

Please visit the [Contact Us](#) section for any non-product compliance questions.

Search Parts in this Series

87715Series

Mates With

PCI Express Card

Sales Drawing
Test Summary

SD-87715-210
TS-87715-210

* PCI Express is a registered trademark of PCI-SIG®

This document was generated on 06/04/2010

PLEASE CHECK WWW.MOLEX.COM FOR LATEST PART INFORMATION

PART NUMBER	DIM A	CONTACT AREA PLATING OPTION	SOLDER TAIL PLATING	PORT SIZE	TOTAL CKTS SIZE
87715-9910	2.54	30 MICROINCH GOLD PLATED	100 MICROINCH MIN TIN OVER NICKEL PLATED OVERALL	8	98
87715-9911	3.00	30 MICROINCH GOLD PLATED	100 MICROINCH MIN TIN OVER NICKEL PLATED OVERALL	8	98

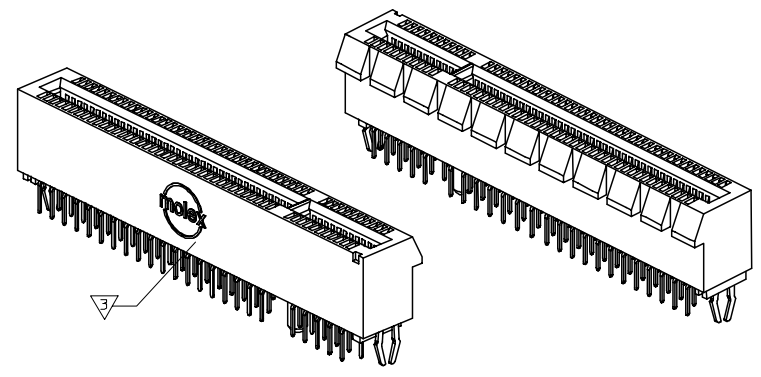
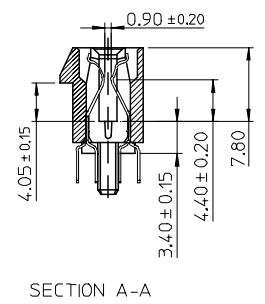
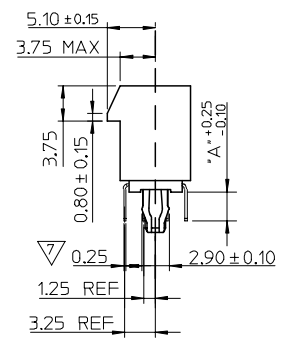
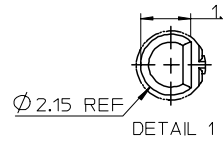
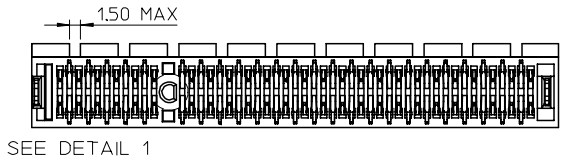
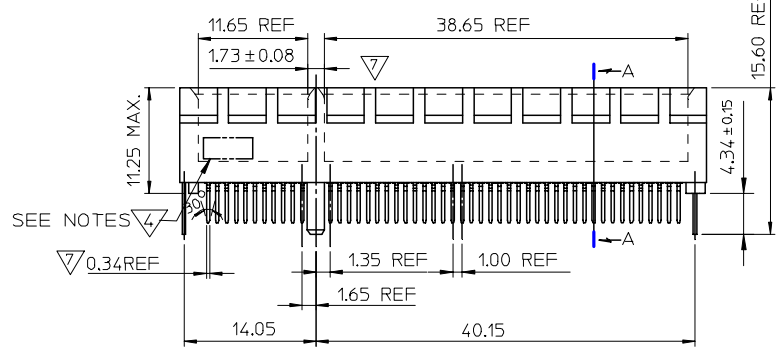
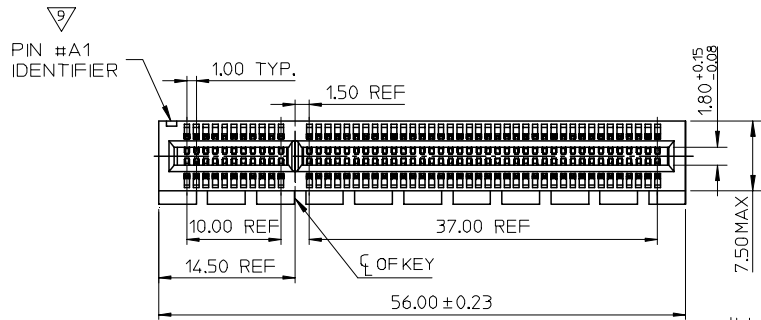

NEW RELEASED EC NO: SH2006-0549 DRWN: ALLIN 2006/05/15 CHKD: 2006/05/15 APPR: WWSCHANG 2006/05/17	QUALITY SYMBOLS ▽ = 0 ◻ = 0	GENERAL TOLERANCES (UNLESS SPECIFIED) mm INCH 4 PLACES ± --- ± --- 3 PLACES ± --- ± --- 2 PLACES ± 0.25 ± --- 1 PLACE ± 0.25 ± --- ANGULAR ± 3 °	DIMENSION STYLE MM ONLY	SCALE DESIGN UNITS METRIC	THIRD ANGLE PROJECTION	
	DRAWN BY KEN LEE	DATE 2006/03/22	TITLE PCI EXPRESS X8 (98 CKTS) VERT DIP WITH BOARD LOCK (LEAD FREE VERSION)			
	CHECKED BY ALLEN LIN	DATE 2006/03/22	MOLEX INCORPORATED			
	APPROVED BY WILSON CHANG	DATE 2006/03/22	MATERIAL NO. SEE TABLE	DOCUMENT NO. SD-87715-210	SHEET NO. 1 OF 3	
DRAFT WHERE APPLICABLE MUST REMAIN WITHIN DIMENSIONS						
THIS DRAWING CONTAINS INFORMATION THAT IS PROPRIETARY TO MOLEX INCORPORATED AND SHOULD NOT BE USED WITHOUT WRITTEN PERMISSION						

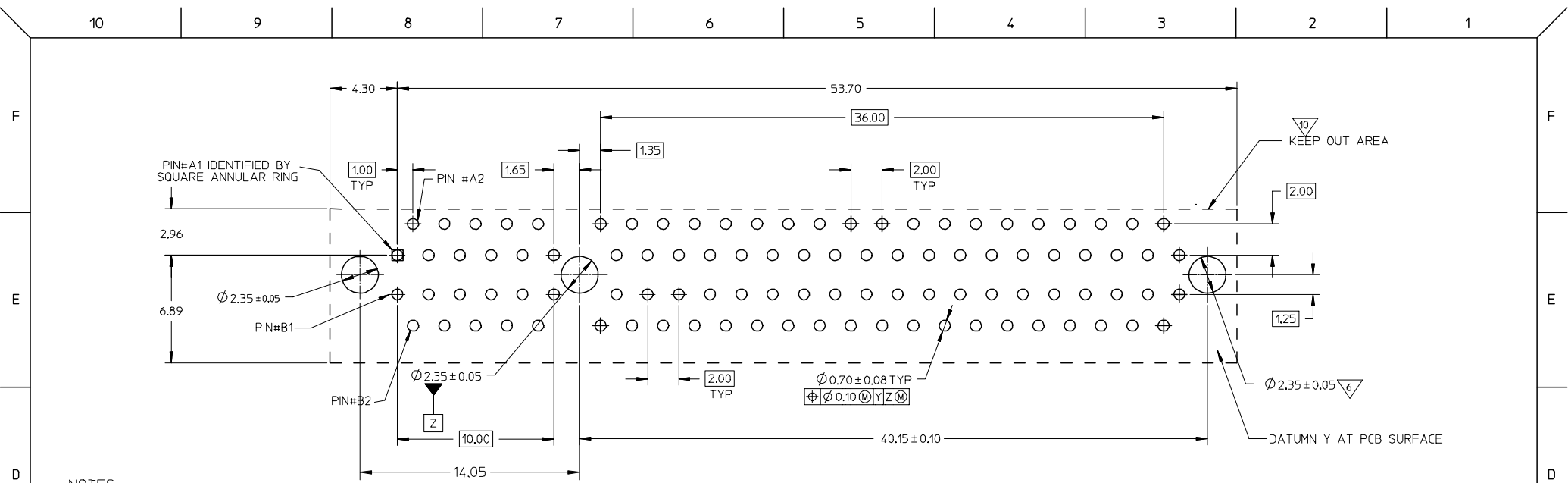

NOTES:

1. MATERIALS: HOUSING - HIGH TEMPERATURE THERMOPLASTIC, GLASS FIBER FILLED, UL 94-V0 (BLACK)
TERMINAL - COPPER ALLOY
2. PLATING: CONTACT AREA - SEE TABLE IN SHEET 1
SOLDER TAILS - SEE TABLE IN SHEET 1
UNDERPLATING - SEE TABLE IN SHEET 1

RECOMMENDED P.C.B. PATTERN
(CONNECTOR SIDE)

THICKNESS: 1.57mm FOR 2.54mm SOLDER TAIL LENGTH
2.35mm FOR 3.00mm SOLDER TAIL LENGTH

3. MOLEX LOGO
4. DATE CODE - TO BE PRINTED
5. CHAMFER EDGES OF EDGE CARD MUST BE FREE OF CUTTING BURRS
6. THE HORIZONTAL AXIS FOR THE FOOTPRINT HOLE PATTERN IS ESTABLISHED BY A LINE THROUGH THE CENTRE OF THE TWO Ø2.35 HOLES. THE VERTICAL AXIS IS 90° TO THE HORIZONTAL AXIS, THROUGH THE CENTRE OF DATUM Z
7. FEATURES DESIGNED TO FUNCTIONALLY MATE/MOUNT(SLIP FIT) PER THE RECOMMENDED EDGE CARD AND PCB PATTERN.
8. PINS FOR HOT PLUG PRESENCE DETECTION. NO TIE BAR PERMITTED FROM CARD EDGE TO LEADING EDGE OF PAD FOR THE HOT PLUG PINS.
9. PIN #1 IDENTIFIER
10. KEEP OUT AREA - NO EXTERNAL COMPONENTS ALLOWED ON PCB SURFACE

11. PRODUCT SPECIFICATION REFER TO PS-87715-200.
12. PACKAGE SPECIFICATION REFER TO PK-87715-204.
13. TEST SUMMARY: REFER TO TS-87715-210.
14. LEAD FREE AND RoHS COMPLIANT PRODUCT.

SEE SHEET 1 EC NO: SH2006-0549 DRWN: ALLIN 2006/05/15 CHKD: 2006/05/15 APPR: WMSCHANG 2006/05/17	QUALITY SYMBOLS ▽=0 ▽=0	GENERAL TOLERANCES (UNLESS SPECIFIED)		DIMENSION STYLE MM ONLY	SCALE NTS	DESIGN UNITS METRIC	THIRD ANGLE PROJECTION	
			mm	INCH	DRAWN BY KEN LEE	DATE 2006/03/22	TITLE PCI EXPRESS X8 (98 CKTS) VERT DIP WITH BOARD LOCK (LEAD FREE VERSION)	
		4 PLACES	± ---	± ---	CHECKED BY ALLEN LIN	DATE 2006/03/22	MOLEX MOLEX INCORPORATED	
		3 PLACES	± ---	± ---	APPROVED BY WILSON CHANG	DATE 2006/03/22	DOCUMENT NO. SD-87715-210	SHEET NO. 2 OF 3
			2 PLACES	± 0.25	± ---			
			1 PLACE	± 0.25	± ---			
			ANGULAR ± 3 °					
			DRAFT WHERE APPLICABLE MUST REMAIN WITHIN DIMENSIONS		SIZE A3 THIS DRAWING CONTAINS INFORMATION THAT IS PROPRIETARY TO MOLEX INCORPORATED AND SHOULD NOT BE USED WITHOUT WRITTEN PERMISSION			

10 9 8 7 6 5 4 3 2 1

F

E

D

C

B

A

F

E

D

C

B

A

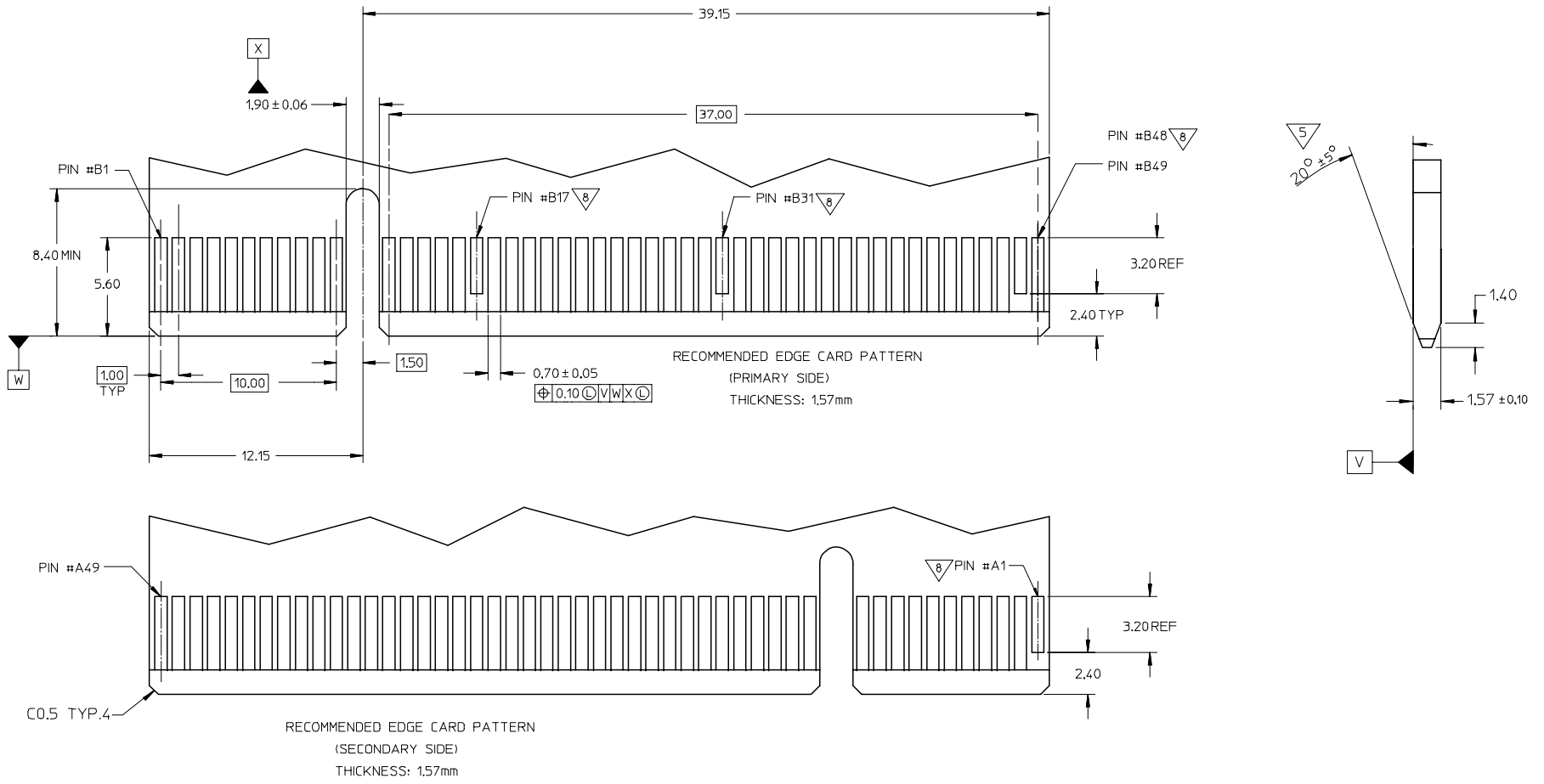

SEE SHEET 1 EC NO: SH2006-0549 DRWN: ALLIN CHKD: APPR: WMSCHANG	2006/05/15 2006/05/15 2006/05/17	DESCRIPTION REV	QUALITY SYMBOLS	GENERAL TOLERANCES (UNLESS SPECIFIED)	DIMENSION STYLE	SCALE	DESIGN UNITS	THIRD ANGLE PROJECTION	
			$\nabla =$ $\nabla C = 0$	mm INCH 4 PLACES ± --- ± --- 3 PLACES ± --- ± --- 2 PLACES ± 0.25 ± --- 1 PLACE ± 0.25 ± --- ANGULAR ± 3 °	MM ONLY	NTS	METRIC		
				DRAFT WHERE APPLICABLE MUST REMAIN WITHIN DIMENSIONS	DRAWN BY: KEN LEE CHECKED BY: ALLEN LIN APPROVED BY: WILSON CHANG DATE: 2006/03/22	TITLE	PCI EXPRESS X8 (98 CKTS) VERT DIP WITH BOARD LOCK (LEAD FREE VERSION)		
					MATERIAL NO. SEE TABLE	DOCUMENT NO. SD-87715-210	MOLEX INCORPORATED		SHEET NO. 3 OF 3

9 8 7 6 5 4 3 2 1

Компания «Life Electronics» занимается поставками электронных компонентов импортного и отечественного производства от производителей и со складов крупных дистрибьюторов Европы, Америки и Азии.

С конца 2013 года компания активно расширяет линейку поставок компонентов по направлению коаксиальный кабель, кварцевые генераторы и конденсаторы (керамические, пленочные, электролитические), за счёт заключения дистрибьюторских договоров

Мы предлагаем:

- Конкурентоспособные цены и скидки постоянным клиентам.
- Специальные условия для постоянных клиентов.
- Подбор аналогов.
- Поставку компонентов в любых объемах, удовлетворяющих вашим потребностям.
- Приемлемые сроки поставки, возможна ускоренная поставка.
- Доставку товара в любую точку России и стран СНГ.
- Комплексную поставку.
- Работу по проектам и поставку образцов.
- Формирование склада под заказчика.
- Сертификаты соответствия на поставляемую продукцию (по желанию клиента).
- Тестирование поставляемой продукции.
- Поставку компонентов, требующих военную и космическую приемку.
- Входной контроль качества.
- Наличие сертификата ISO.

В составе нашей компании организован Конструкторский отдел, призванный помогать разработчикам, и инженерам.

Конструкторский отдел помогает осуществить:

- Регистрацию проекта у производителя компонентов.
- Техническую поддержку проекта.
- Защиту от снятия компонента с производства.
- Оценку стоимости проекта по компонентам.
- Изготовление тестовой платы монтаж и пусконаладочные работы.



Тел: +7 (812) 336 43 04 (многоканальный)

Email: org@lifeelectronics.ru