

## N-channel 600 V, 0.63 $\Omega$ typ., 6.5 A MDmesh™ II Power MOSFETs in DPAK, TO-220FP and TO-220 packages

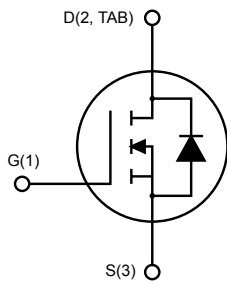
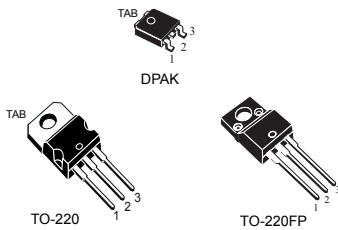

AM01475v1\_noZen

### Features

Order code	$V_{DS}$	$R_{DS(on)}$ max.	$I_D$	Package
STD9NM60N	600 V	0.745 $\Omega$	6.5 A	DPAK
STF9NM60N				TO-220FP
STP9NM60N				TO-220

- 100% avalanche tested
- Low input capacitance and gate charge
- Low gate input resistance

### Applications

- Switching applications

### Description

These devices are N-channel Power MOSFETs developed using the second generation of MDmesh™ technology. These revolutionary Power MOSFETs associate a vertical structure to the company's strip layout to yield one of the world's lowest on-resistance and gate charge. They are therefore suitable for the most demanding high-efficiency converters.

#### Product status link

[STD9NM60N](#)
[STF9NM60N](#)
[STP9NM60N](#)

# 1 Electrical ratings

**Table 1. Absolute maximum ratings**

Symbol	Parameter	Value		Unit
		DPAK, TO-220	TO-220FP	
$V_{DS}$	Drain-source voltage	600		V
$V_{GS}$	Gate-source voltage	±25		V
$I_D$	Drain current (continuous) at $T_C = 25\text{ °C}$	6.5	6.5 <sup>(1)</sup>	A
$I_D$	Drain current (continuous) at $T_C = 100\text{ °C}$	4	4 <sup>(1)</sup>	A
$I_{DM}^{(2)}$	Drain current (pulsed)	26	26 <sup>(1)</sup>	A
$P_{TOT}$	Total dissipation at $T_C = 25\text{ °C}$	70	25	W
$dv/dt^{(3)}$	Peak diode recovery voltage slope	15		V/ns
$V_{ISO}$	Insulation withstand voltage (RMS) from all three leads to external heat sink ( $t = 1\text{ s}$ ; $T_C = 25\text{ °C}$ )	2.5		kV
$T_j$	Operating junction temperature range	-55 to 150		°C
$T_{stg}$	Storage temperature range			

- Limited by maximum junction temperature.
- Pulse width limited by safe operating area.
- $I_{SD} \leq 6.5\text{ A}$ ,  $di/dt \leq 400\text{ A}/\mu\text{s}$ ,  $V_{DD} = 80\% V_{(BR)DSS}$ .

**Table 2. Thermal data**

Symbol	Parameter	Value			Unit
		DPAK	TO-220	TO-220FP	
$R_{thj-case}$	Thermal resistance junction-case	1.79		5	°C/W
$R_{thj-amb}$	Thermal resistance junction-ambient	62.5			
$R_{thj-pcb}^{(1)}$	Thermal resistance junction-pcb	50			

- When mounted on 1inch<sup>2</sup> FR-4, 2 Oz copper board.

**Table 3. Avalanche characteristics**

Symbol	Parameter	Value	Unit
$I_{AR}$	Avalanche current, repetitive or not-repetitive (pulse width limited by $T_j$ Max)	2.5	A
$E_{AS}$	Single pulse avalanche energy (starting $T_j = 25\text{ °C}$ , $I_D = I_{AR}$ , $V_{DD} = 50\text{ V}$ )	115	mJ

## 2 Electrical characteristics

( $T_{CASE} = 25\text{ °C}$  unless otherwise specified)

**Table 4. On/off states**

Symbol	Parameter	Test conditions	Min.	Typ.	Max.	Unit
$V_{(BR)DSS}$	Drain-source breakdown voltage	$I_D = 1\text{ mA}$ , $V_{GS} = 0\text{ V}$	600			V
$I_{DSS}$	Zero gate voltage drain current	$V_{GS} = 0\text{ V}$ , $V_{DS} = 600\text{ V}$			1	$\mu\text{A}$
		$V_{GS} = 0\text{ V}$ , $V_{DS} = 600\text{ V}$ , $T_C = 125\text{ °C}$ <sup>(1)</sup>			100	$\mu\text{A}$
$I_{GSS}$	Gate body leakage current	$V_{DS} = 0\text{ V}$ , $V_{GS} = \pm 20\text{ V}$			100	nA
$V_{GS(th)}$	Gate threshold voltage	$V_{DS} = V_{GS}$ , $I_D = 250\text{ }\mu\text{A}$	2	3	4	V
$R_{DS(on)}$	Static drain-source on resistance	$V_{GS} = 10\text{ V}$ , $I_D = 3.25\text{ A}$		0.63	0.745	$\Omega$

1. Defined by design, not subject to production test.

**Table 5. Dynamic**

Symbol	Parameter	Test conditions	Min.	Typ.	Max.	Unit
$C_{iss}$	Input capacitance	$V_{DS} = 50\text{ V}$ , $f = 1\text{ MHz}$ , $V_{GS} = 0\text{ V}$	-	452	-	$\mu\text{F}$
$C_{oss}$	Output capacitance			30		
$C_{rSS}$	Reverse transfer capacitance			1.45		
$C_{oss\ eq.}^{(1)}$	Equivalent output capacitance	$V_{DS} = 0\text{ to }480\text{ V}$ , $V_{GS} = 0\text{ V}$	-	79	-	$\mu\text{F}$
$R_g$	Gate input resistance	$f = 1\text{ MHz}$ , $I_D = 0\text{ A}$	-	4.8	-	$\Omega$
$Q_g$	Total gate charge	$V_{DD} = 480\text{ V}$ , $I_D = 6.5\text{ A}$ , $V_{GS} = 0\text{ to }10\text{ V}$ (see Figure 17. Test circuit for gate charge behavior)	-	17.4	-	nC
$Q_{gs}$	Gate-source charge			3		
$Q_{gd}$	Gate-drain charge			9.7		

1.  $C_{oss\ eq.}$  is defined as a constant equivalent capacitance giving the same charging time as  $C_{oss}$  when  $V_{DS}$  increases from 0 to 80%  $V_{DSS}$ .

**Table 6. Switching times**

Symbol	Parameter	Test conditions	Min.	Typ.	Max.	Unit
$t_{d(on)}$	Turn-on delay time	$V_{DD} = 480\text{ V}$ , $I_D = 6.5\text{ A}$ , $R_G = 4.7\text{ }\Omega$ , $V_{GS} = 10\text{ V}$	-	28	-	ns
$t_r$	Rise time			23		
$t_{d(off)}$	Turn-off delay time	(see Figure 16. Test circuit for resistive load switching times and Figure 21. Switching time waveform)	-	52.5	-	ns
$t_f$	Fall time			26.7		

**Table 7. Source drain diode**

Symbol	Parameter	Test conditions	Min.	Typ.	Max.	Unit
$I_{SD}$	Source-drain current				6.5	A
$I_{SDM}^{(1)}$	Source-drain current (pulsed)		-		26	
$V_{SD}^{(2)}$	Forward on voltage	$I_{SD} = 6.5 \text{ A}$ , $V_{GS} = 0 \text{ V}$	-		1.6	V
$t_{rr}$	Reverse recovery time	$I_{SD} = 6.5 \text{ A}$ , $di/dt = 100 \text{ A}/\mu\text{s}$		264		ns
$Q_{rr}$	Reverse recovery charge	$V_{DD} = 60 \text{ V}$ (see <a href="#">Figure 18. Test circuit for inductive load switching and diode recovery times</a> )	-	1.9		$\mu\text{C}$
$I_{RRM}$	Reverse recovery current			14.6		A
$t_{rr}$	Reverse recovery time	$I_{SD} = 6.5 \text{ A}$ , $di/dt = 100 \text{ A}/\mu\text{s}$		324		ns
$Q_{rr}$	Reverse recovery charge	$V_{DD} = 60 \text{ V}$ (see <a href="#">Figure 18. Test circuit for inductive load switching and diode recovery times</a> )	-	2.3		$\mu\text{C}$
$I_{RRM}$	Reverse recovery current			14.2		A

1. Pulse width limited by safe operating area.
2. Pulsed: pulse duration = 300  $\mu\text{s}$ , duty cycle 1.5%.

## 2.1 Electrical characteristics curves

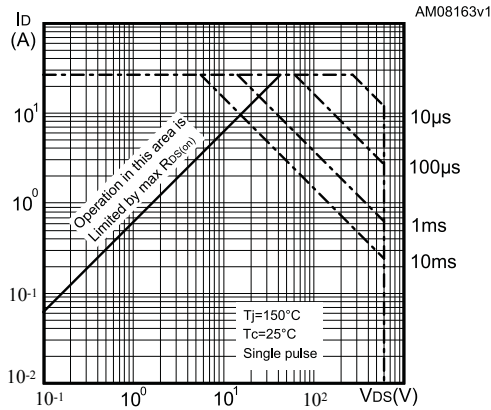
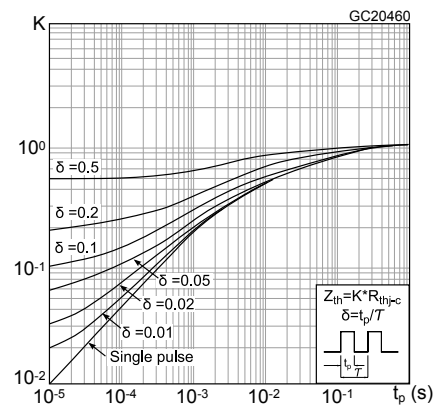
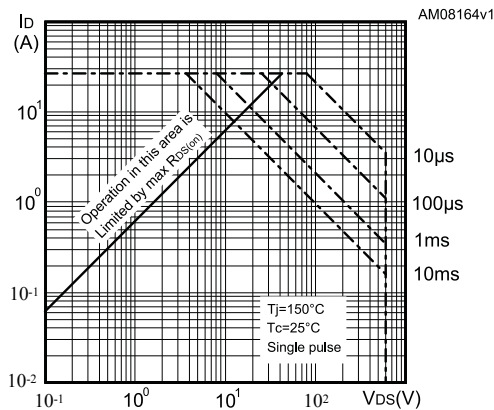
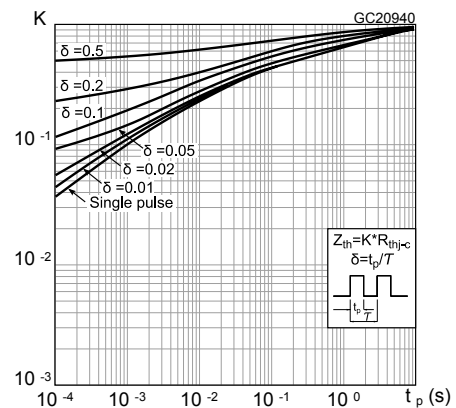
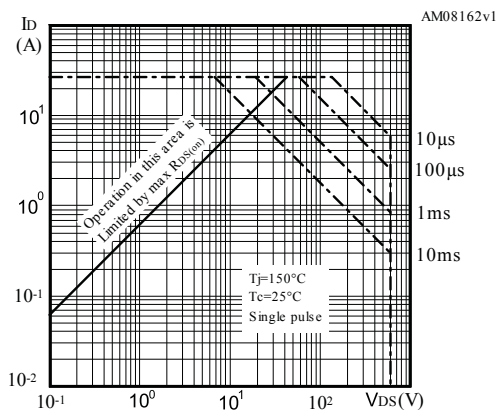
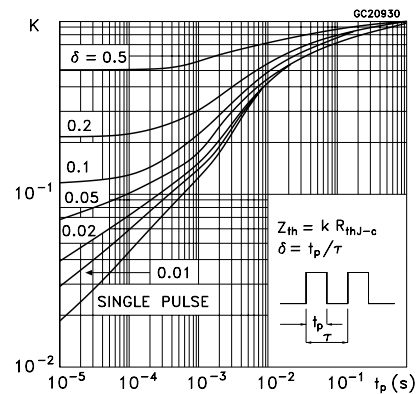
**Figure 1. Safe operating area for DPAK**

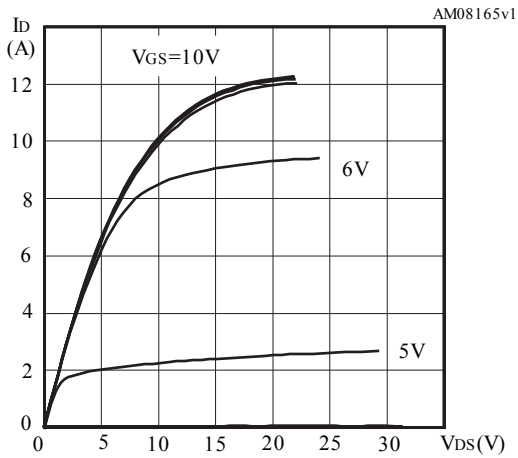
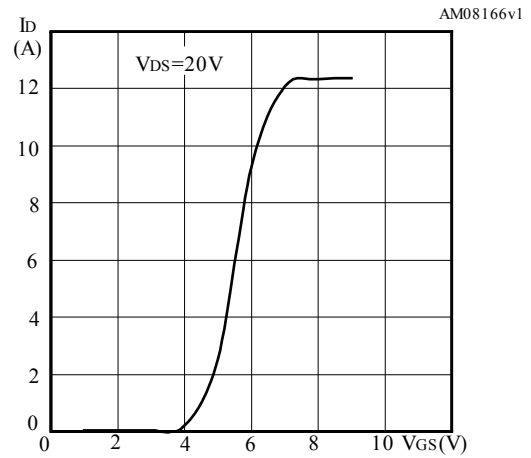
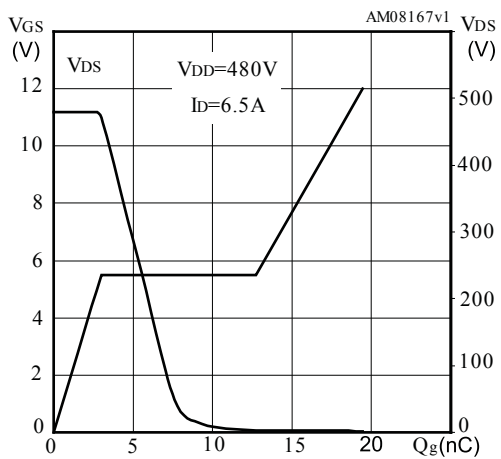
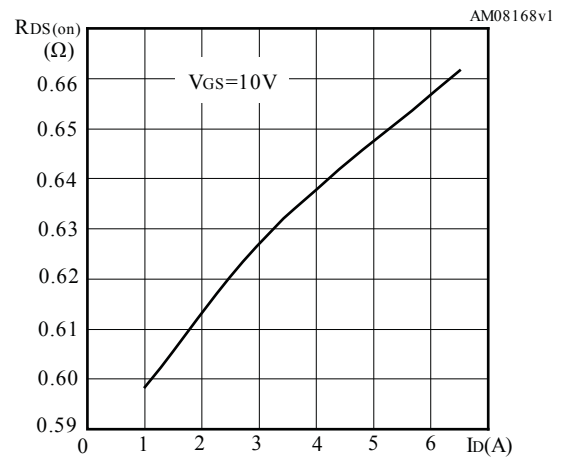
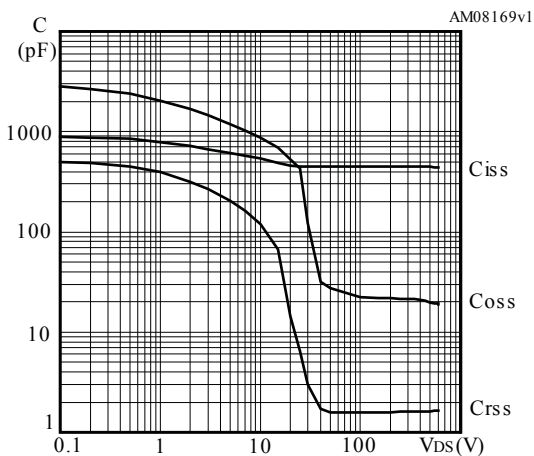
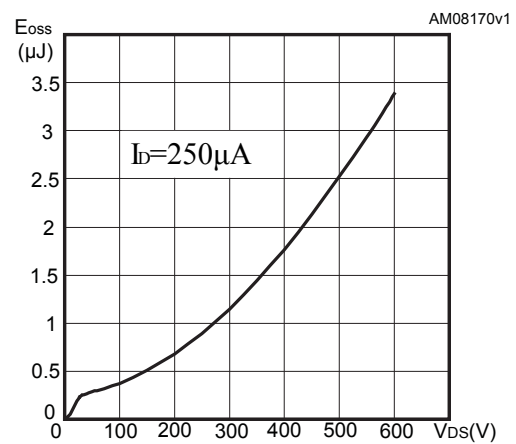
**Figure 2. Thermal impedance for DPAK**

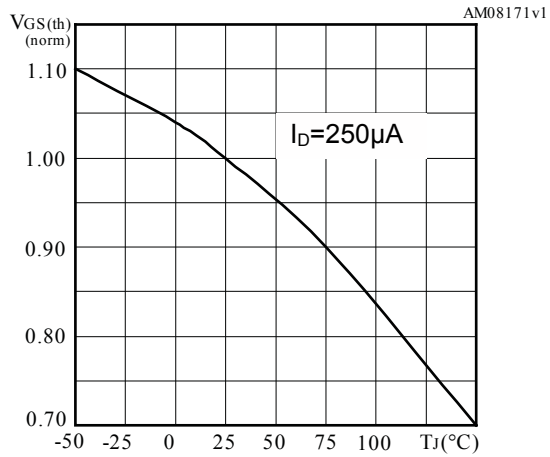
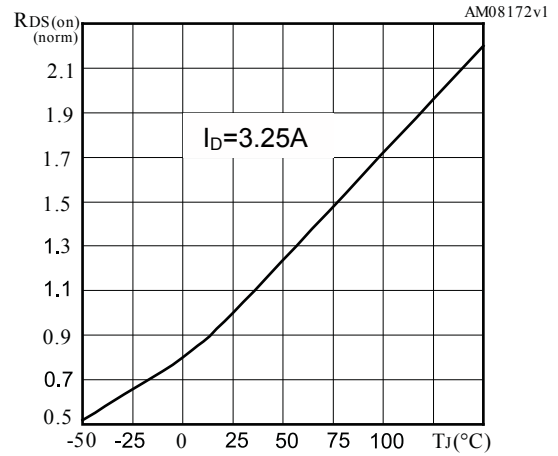
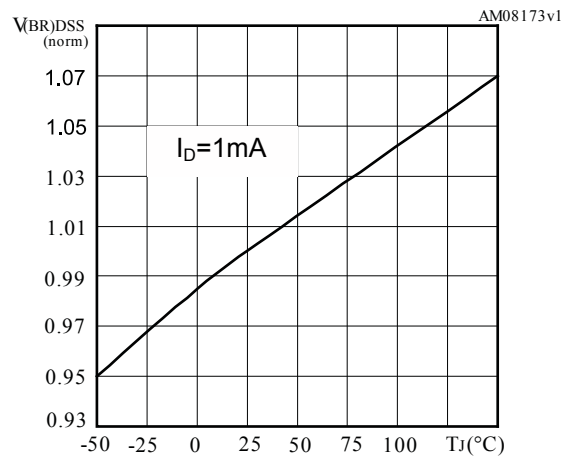
**Figure 3. Safe operating area for TO-220FP**

**Figure 4. Thermal impedance for TO-220FP**

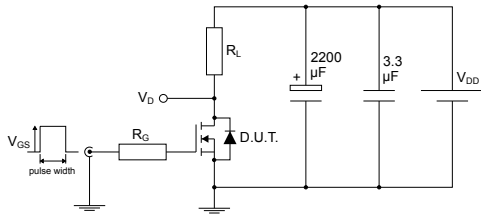
**Figure 5. Safe operating area for TO-220**

**Figure 6. Thermal impedance for TO-220**

**Figure 7. Output characteristics**

**Figure 8. Transfer characteristics**

**Figure 9. Gate charge vs gate-source voltage**

**Figure 10. Static drain-source on resistance**

**Figure 11. Capacitance variations**

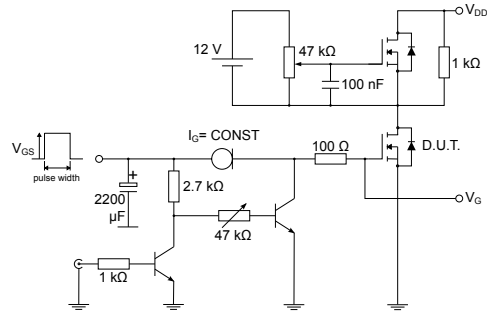
**Figure 12. Output capacitance stored energy**

**Figure 13. Normalized gate threshold voltage vs temperature**

**Figure 14. Normalized on resistance vs temperature**

**Figure 15. Normalized  $V_{(BR)DSS}$  vs temperature**

### 3 Test circuits

**Figure 16. Test circuit for resistive load switching times**

AM01468v1

**Figure 17. Test circuit for gate charge behavior**

AM01469v1

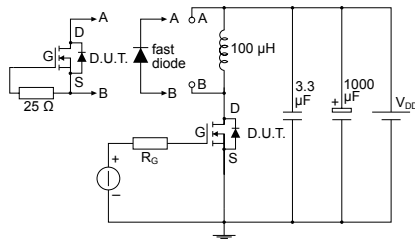
**Figure 18. Test circuit for inductive load switching and diode recovery times**

AM01470v1

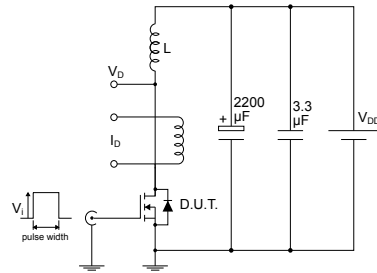
**Figure 19. Unclamped inductive load test circuit**

AM01471v1

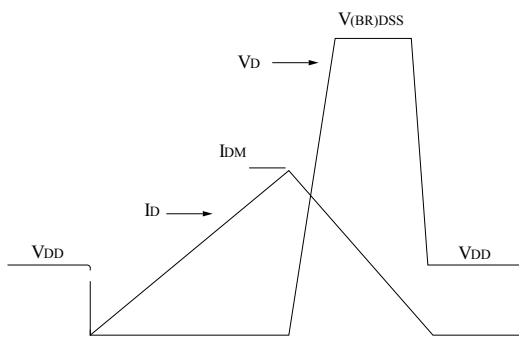
**Figure 20. Unclamped inductive waveform**

AM01472v1

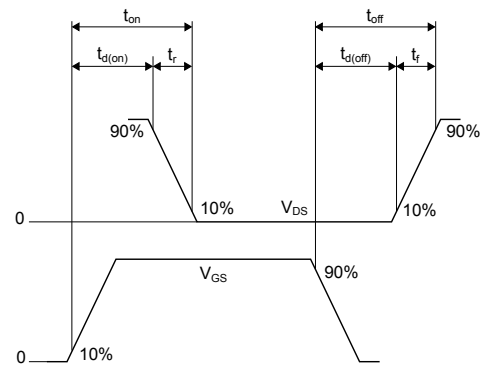
**Figure 21. Switching time waveform**

AM01473v1

## 4 Package information

---

In order to meet environmental requirements, ST offers these devices in different grades of ECOPACK® packages, depending on their level of environmental compliance. ECOPACK® specifications, grade definitions and product status are available at: [www.st.com](http://www.st.com). ECOPACK® is an ST trademark.

**4.1 DPAK (TO-252) type A package information**

Figure 22. DPAK (TO-252) type A package outline

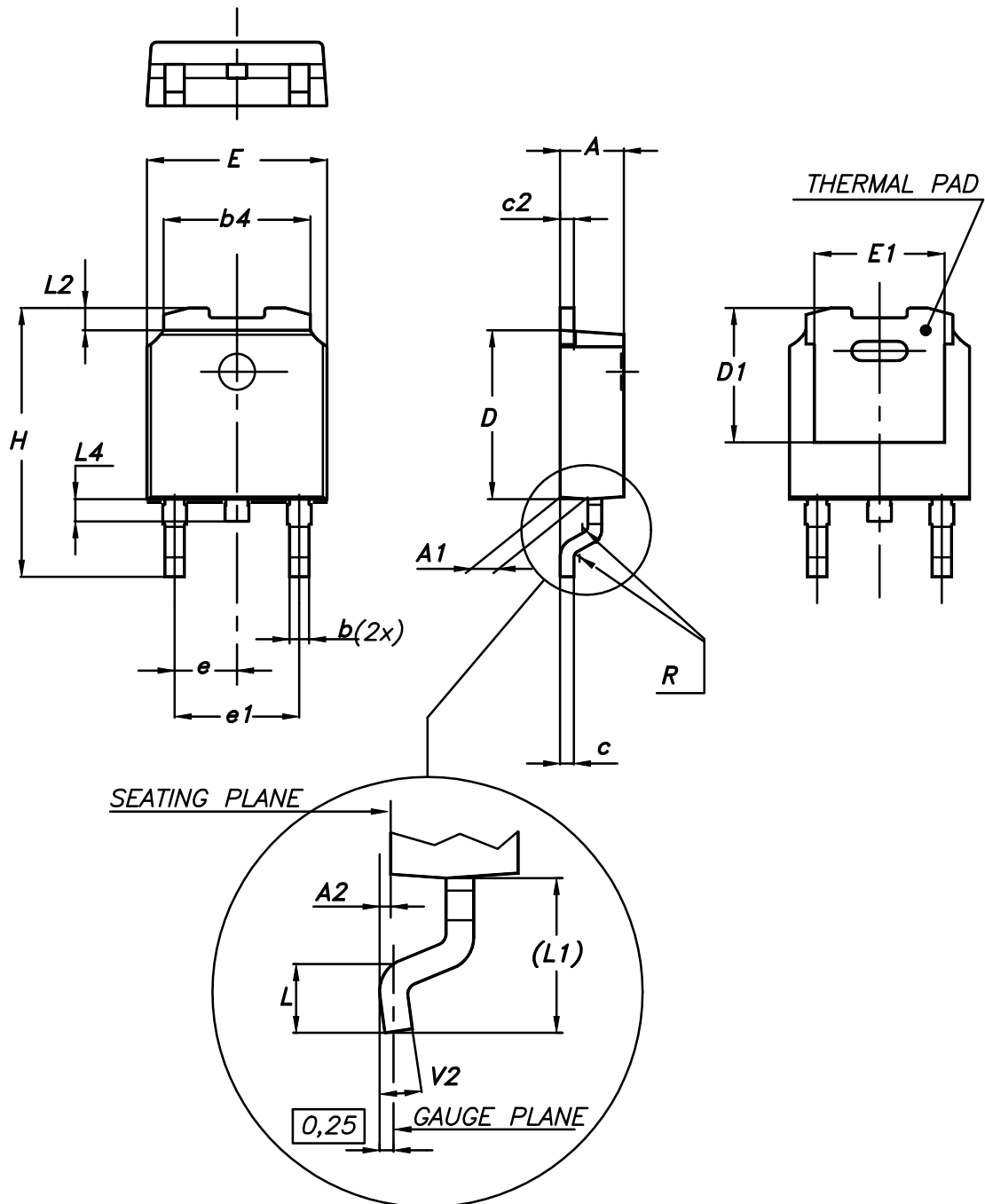

0068772\_A\_25

**Table 8. DPAK (TO-252) type A mechanical data**

Dim.	mm		
	Min.	Typ.	Max.
A	2.20		2.40
A1	0.90		1.10
A2	0.03		0.23
b	0.64		0.90
b4	5.20		5.40
c	0.45		0.60
c2	0.48		0.60
D	6.00		6.20
D1	4.95	5.10	5.25
E	6.40		6.60
E1	4.60	4.70	4.80
e	2.159	2.286	2.413
e1	4.445	4.572	4.699
H	9.35		10.10
L	1.00		1.50
(L1)	2.60	2.80	3.00
L2	0.65	0.80	0.95
L4	0.60		1.00
R		0.20	
V2	0°		8°

**4.2 DPAK (TO-252) type C2 package information**

Figure 23. DPAK (TO-252) type C2 package outline

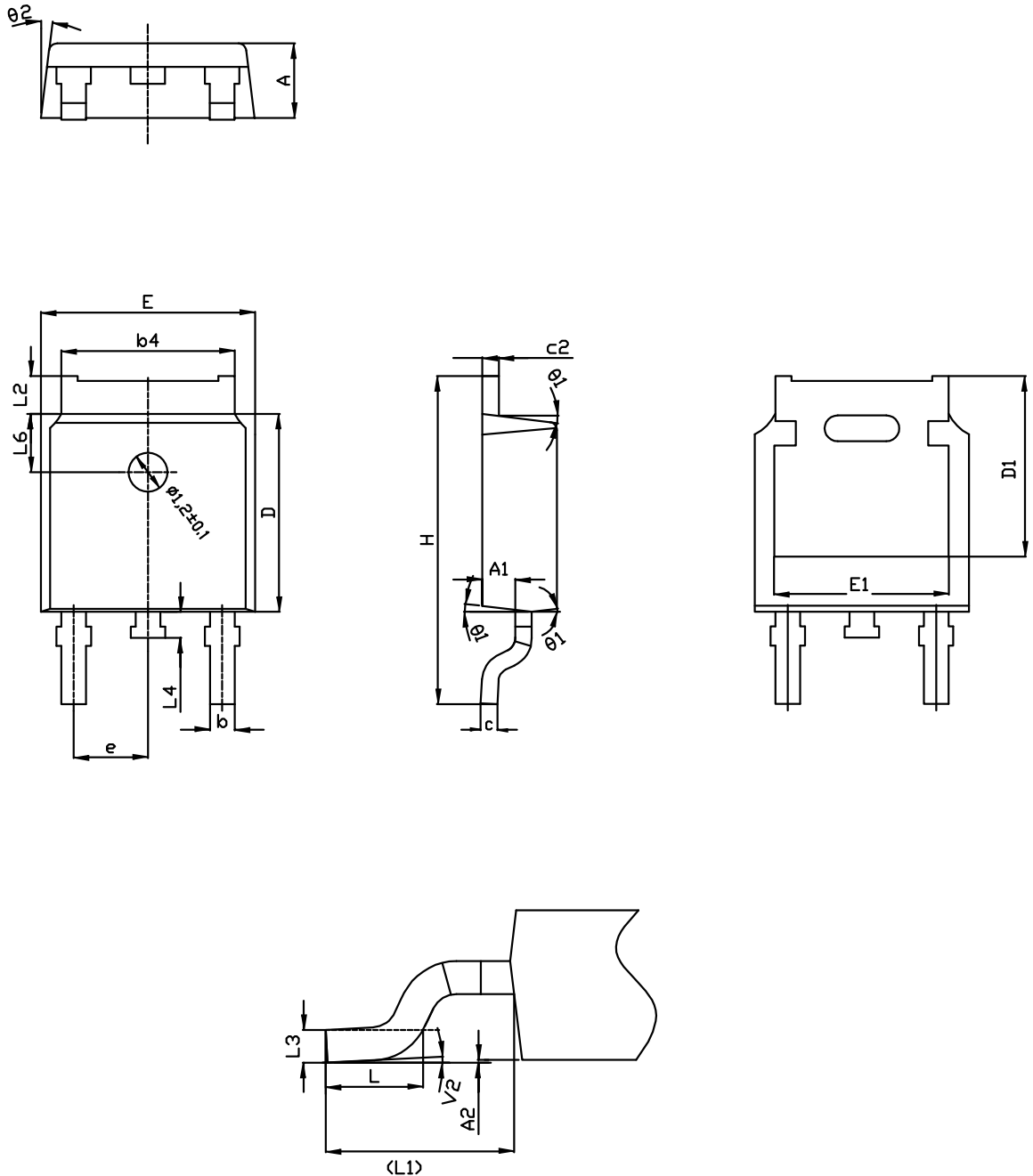

0068772\_C2\_25

**Table 9. DPAK (TO-252) type C2 mechanical data**

Dim.	mm		
	Min.	Typ.	Max.
A	2.20	2.30	2.38
A1	0.90	1.01	1.10
A2	0.00		0.10
b	0.72		0.85
b4	5.13	5.33	5.46
c	0.47		0.60
c2	0.47		0.60
D	6.00	6.10	6.20
D1	5.10		5.60
E	6.50	6.60	6.70
E1	5.20		5.50
e	2.186	2.286	2.386
H	9.80	10.10	10.40
L	1.40	1.50	1.70
L1	2.90 REF		
L2	0.90		1.25
L3	0.51 BSC		
L4	0.60	0.80	1.00
L6	1.80 BSC		
θ1	5°	7°	9°
θ2	5°	7°	9°
V2	0°		8°

Figure 24. DPAK (TO-252) recommended footprint (dimensions are in mm)

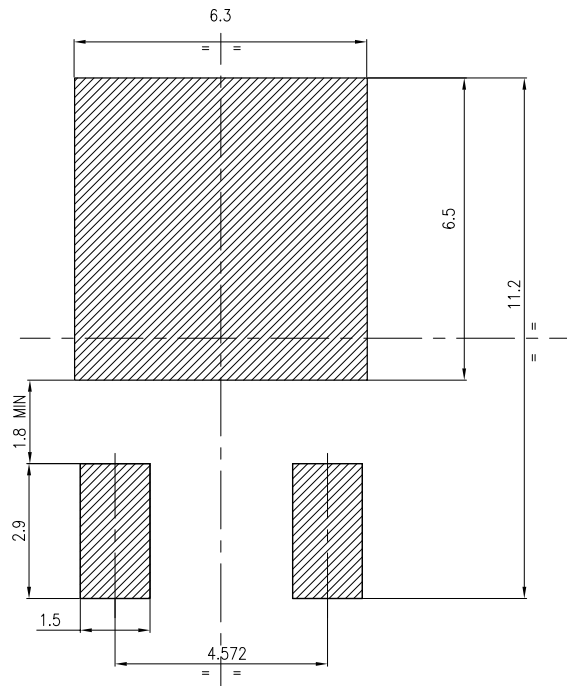

FP\_0068772\_25

### 4.3 DPAK (TO-252) packing information

Figure 25. DPAK (TO-252) tape outline

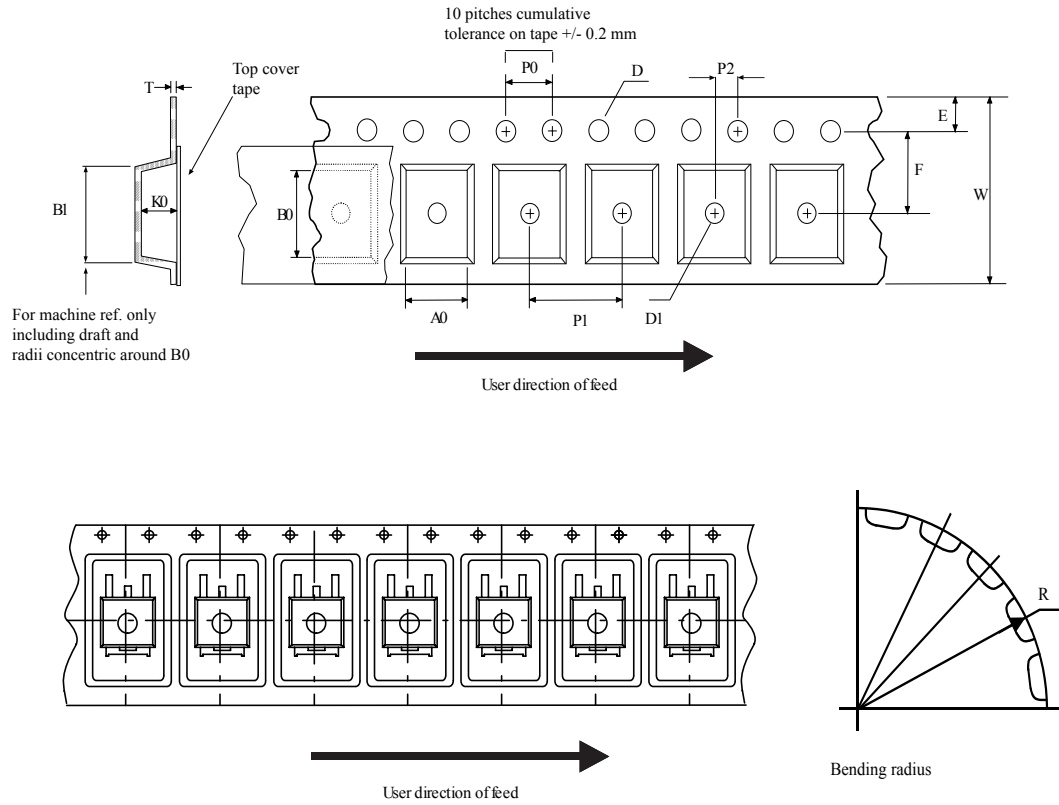

AM08852v1

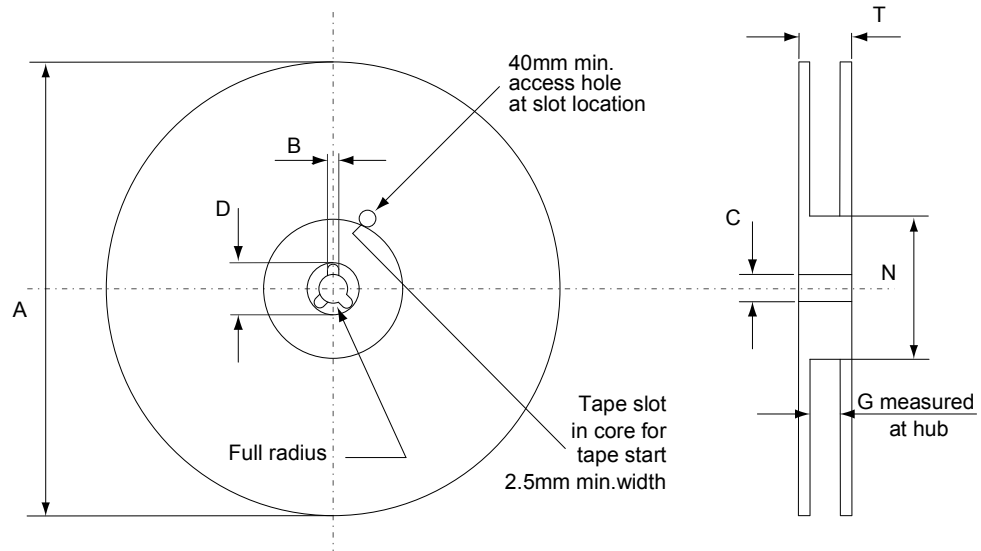
**Figure 26. DPAK (TO-252) reel outline**

AM06038v1

**Table 10. DPAK (TO-252) tape and reel mechanical data**

Tape			Reel		
Dim.	mm		Dim.	mm	
	Min.	Max.		Min.	Max.
A0	6.8	7	A		330
B0	10.4	10.6	B	1.5	
B1		12.1	C	12.8	13.2
D	1.5	1.6	D	20.2	
D1	1.5		G	16.4	18.4
E	1.65	1.85	N	50	
F	7.4	7.6	T		22.4
K0	2.55	2.75			
P0	3.9	4.1	Base qty.		2500
P1	7.9	8.1	Bulk qty.		2500
P2	1.9	2.1			
R	40				
T	0.25	0.35			
W	15.7	16.3			

#### 4.4 TO-220FP package information

Figure 27. TO-220FP package outline

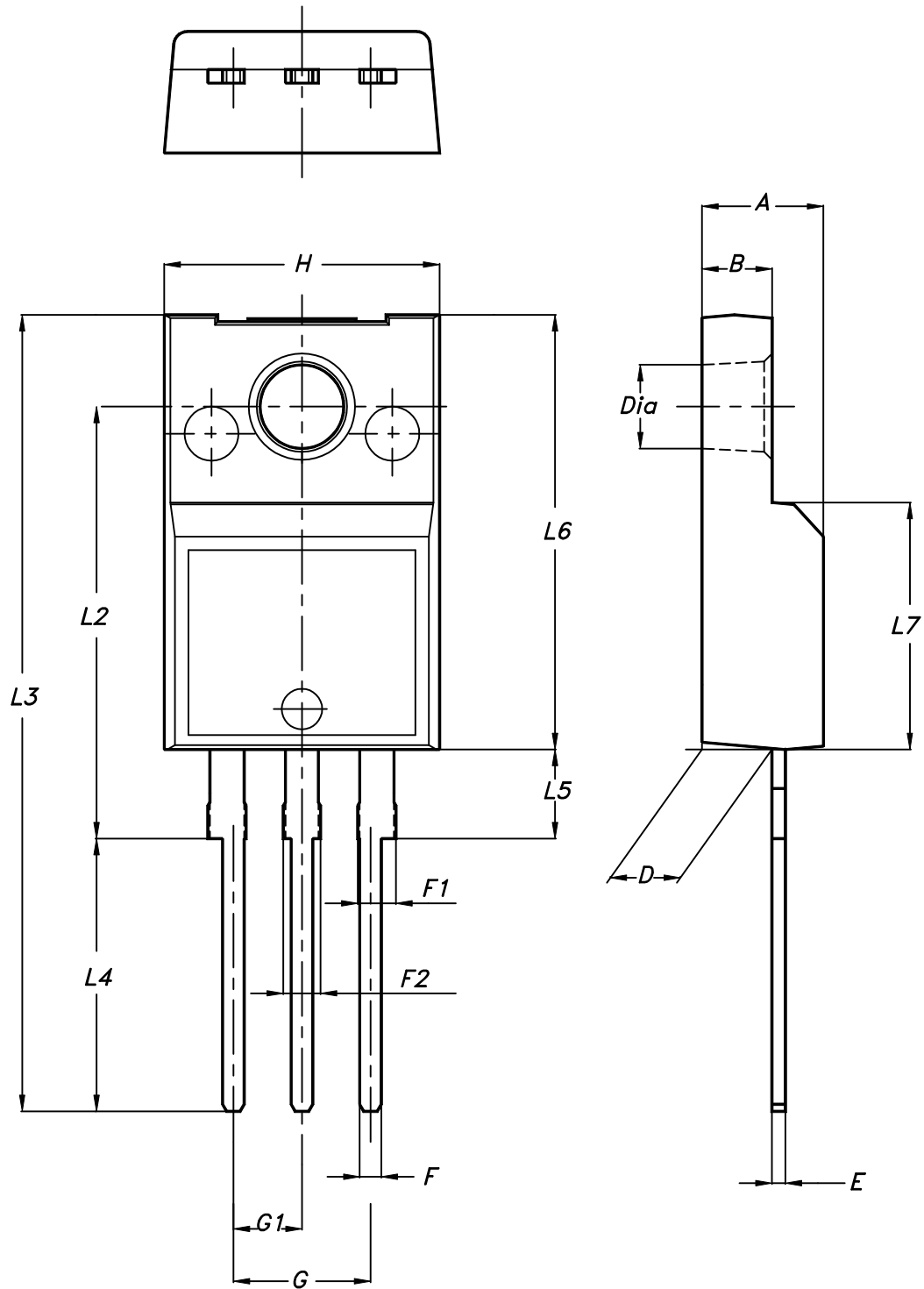

7012510\_Rev\_12\_B

**Table 11. TO-220FP package mechanical data**

Dim.	mm		
	Min.	Typ.	Max.
A	4.4		4.6
B	2.5		2.7
D	2.5		2.75
E	0.45		0.7
F	0.75		1
F1	1.15		1.70
F2	1.15		1.70
G	4.95		5.2
G1	2.4		2.7
H	10		10.4
L2		16	
L3	28.6		30.6
L4	9.8		10.6
L5	2.9		3.6
L6	15.9		16.4
L7	9		9.3
Dia	3		3.2

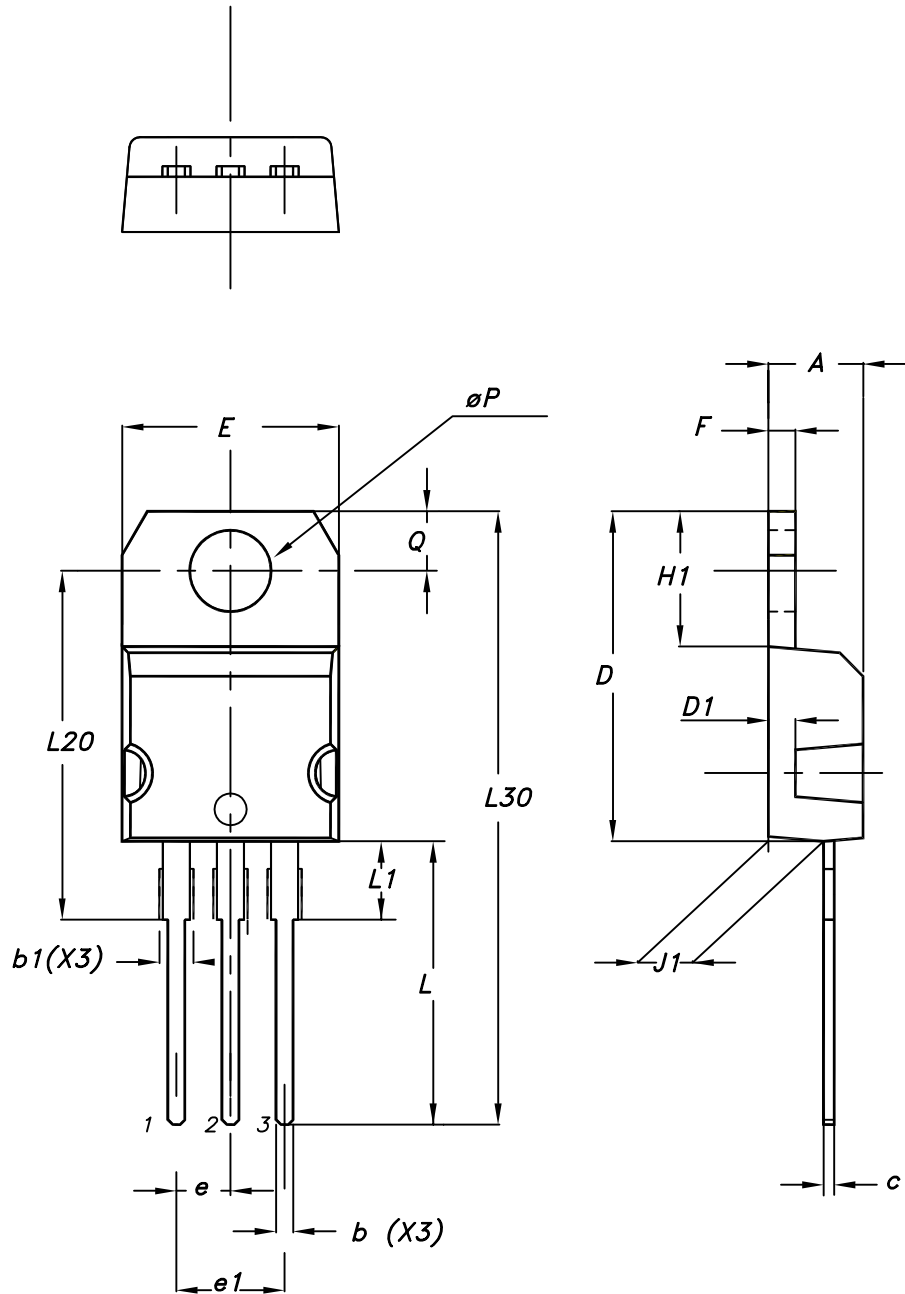
**4.5 TO-220 type A package information**
**Figure 28. TO-220 type A package outline**

0015988\_typeA\_Rev\_21

**Table 12. TO-220 type A package mechanical data**

Dim.	mm		
	Min.	Typ.	Max.
A	4.40		4.60
b	0.61		0.88
b1	1.14		1.55
c	0.48		0.70
D	15.25		15.75
D1		1.27	
E	10.00		10.40
e	2.40		2.70
e1	4.95		5.15
F	1.23		1.32
H1	6.20		6.60
J1	2.40		2.72
L	13.00		14.00
L1	3.50		3.93
L20		16.40	
L30		28.90	
øP	3.75		3.85
Q	2.65		2.95

## 5 Ordering information

**Table 13. Order codes**

Order code	Marking	Package	Packing
STD9NM60N	9NM60N	DPAK	Tape and reel
STF9NM60N		TO-220FP	Tube
STP9NM60N		TO-220	

## Revision history

**Table 14. Document revision history**

Date	Version	Changes
20-Oct-2010	1	First release.
25-Sep-2018	2	Removed maturity status indication from cover page. The document status is production data. Updated <a href="#">Section 4 Package information</a> . Minor text changes.

## Contents

<b>1</b>	<b>Electrical ratings</b> .....	<b>2</b>
<b>2</b>	<b>Electrical characteristics</b> .....	<b>3</b>
<b>2.1</b>	Electrical characteristics curves .....	5
<b>3</b>	<b>Test circuits</b> .....	<b>8</b>
<b>4</b>	<b>Package information</b> .....	<b>9</b>
<b>4.1</b>	DPAK (TO-252) type A package information .....	9
<b>4.2</b>	DPAK (TO-252) type C2 package information .....	11
<b>4.3</b>	DPAK (TO-252) packing information .....	14
<b>4.4</b>	TO-220FP package information .....	16
<b>4.5</b>	TO-220 type A package information .....	18
<b>5</b>	<b>Ordering information</b> .....	<b>21</b>
	<b>Revision history</b> .....	<b>22</b>

**IMPORTANT NOTICE – PLEASE READ CAREFULLY**

STMicroelectronics NV and its subsidiaries (“ST”) reserve the right to make changes, corrections, enhancements, modifications, and improvements to ST products and/or to this document at any time without notice. Purchasers should obtain the latest relevant information on ST products before placing orders. ST products are sold pursuant to ST’s terms and conditions of sale in place at the time of order acknowledgement.

Purchasers are solely responsible for the choice, selection, and use of ST products and ST assumes no liability for application assistance or the design of Purchasers’ products.

No license, express or implied, to any intellectual property right is granted by ST herein.

Resale of ST products with provisions different from the information set forth herein shall void any warranty granted by ST for such product.

ST and the ST logo are trademarks of ST. All other product or service names are the property of their respective owners.

Information in this document supersedes and replaces information previously supplied in any prior versions of this document.

© 2018 STMicroelectronics – All rights reserved

Компания «Life Electronics» занимается поставками электронных компонентов импортного и отечественного производства от производителей и со складов крупных дистрибьюторов Европы, Америки и Азии.

С конца 2013 года компания активно расширяет линейку поставок компонентов по направлению коаксиальный кабель, кварцевые генераторы и конденсаторы (керамические, пленочные, электролитические), за счёт заключения дистрибьюторских договоров

Мы предлагаем:

- Конкурентоспособные цены и скидки постоянным клиентам.
- Специальные условия для постоянных клиентов.
- Подбор аналогов.
- Поставку компонентов в любых объемах, удовлетворяющих вашим потребностям.
- Приемлемые сроки поставки, возможна ускоренная поставка.
- Доставку товара в любую точку России и стран СНГ.
- Комплексную поставку.
- Работу по проектам и поставку образцов.
- Формирование склада под заказчика.
- Сертификаты соответствия на поставляемую продукцию (по желанию клиента).
- Тестирование поставляемой продукции.
- Поставку компонентов, требующих военную и космическую приемку.
- Входной контроль качества.
- Наличие сертификата ISO.

В составе нашей компании организован Конструкторский отдел, призванный помогать разработчикам, и инженерам.

Конструкторский отдел помогает осуществить:

- Регистрацию проекта у производителя компонентов.
- Техническую поддержку проекта.
- Защиту от снятия компонента с производства.
- Оценку стоимости проекта по компонентам.
- Изготовление тестовой платы монтаж и пусконаладочные работы.



Тел: +7 (812) 336 43 04 (многоканальный)

Email: [org@lifeelectronics.ru](mailto:org@lifeelectronics.ru)