

Sensorless Motor Control IC for Appliances

Features

- **MCE™ (Motion Control Engine) - Hardware based computation engine for high efficiency sinusoidal sensorless control of permanent magnet AC motor**
- **Integrated Power Factor Correction control**
- **Supports both interior and surface permanent magnet motors**
- **Built-in hardware peripheral for single shunt current feedback reconstruction**
- **No external current or voltage sensing operational amplifier required**
- **Three/two-phase Space Vector PWM**
- **Three-channel analog output (PWM)**
- **Embedded 8-bit high speed microcontroller (8051) for flexible I/O and man-machine control**
- **JTAG programming port for emulation/debugger**
- **Serial communication interface (UART)**
- **I²C/SPI serial interface**
- **Watchdog timer with independent analog clock**
- **Three general purpose timers/counters**
- **Two special timers: periodic timer, capture timer**
- **Internal 'One-Time Programmable' (OTP) memory and internal RAM for final production usage**
- **Pin compatible with IRMCK343, RAM version**
- **1.8V/3.3V CMOS**

Product Summary

Maximum crystal frequency	60 MHz
Maximum internal clock (SYSCLK) frequency	128 MHz
Maximum 8051 clock frequency	33 MHz
Sensorless control computation time	11 µsec typ
MCE™ computation data range	16 bit signed
8051 OTP Program memory	56K bytes
MCE program and Data RAM	8K bytes
GateKill latency (digital filtered)	2 µsec
PWM carrier frequency counter	16 bits/ SYSCLK
A/D input channels	5
A/D converter resolution	12 bits
A/D converter conversion speed	2 µsec
8051 instruction execution speed	2 SYSCLK
Analog output (PWM) resolution	8 bits
UART baud rate (typ)	57.6K bps
Number of I/O (max)	23
Package (lead-free)	QFP64
Operating temperature	-40°C ~ 85°C

Description

IRMCK343 is a high performance OTP based motion control IC designed primarily for appliance applications. IRMCK343 is designed to achieve low cost and high performance control solutions for advanced inverterized appliance motor control. IRMCK343 contains two computation engines. One is Motion Control Engine (MCE™) for sensorless control of permanent magnet motors; the other is an 8-bit high-speed microcontroller (8051). Both computation engines are integrated into one monolithic chip. The MCE™ contains a collection of control elements such as Proportional plus Integral, Vector rotator, Angle estimator, Multiply/Divide, Low loss SVPWM, Single Shunt IFB. The user can program a motion control algorithm by connecting these control elements using a graphic compiler. Key components of the sensorless control algorithms, such as the Angle Estimator, are provided as complete pre-defined control blocks implemented in hardware. A unique analog/digital circuit and algorithm to fully support single shunt current reconstruction is also provided. The 8051 microcontroller performs 2-cycle instruction execution (60MIPS at 120MHz). The MCE and 8051 microcontroller are connected via dual port RAM to process signal monitoring and command input. An advanced graphic compiler for the MCE™ is seamlessly integrated into the MATLAB/Simulink environment, while third party JTAG based emulator tools are supported for 8051 developments. IRMCK343 comes with a small QFP64 pin lead-free package.

TABLE OF CONTENTS

1	Overview	5
2	IRMCK343 Block Diagram and Main Functions	6
3	Pinout	8
4	Input/Output of IRMCK343	9
4.1	8051 Peripheral Interface Group	9
4.2	Motion Peripheral Interface Group	10
4.3	Analog Interface Group	11
4.4	Power Interface Group	11
4.5	Test Interface Group	11
5	Application Connections	12
6	DC Characteristics	13
6.1	Absolute Maximum Ratings	13
6.2	System Clock Frequency and Power Consumption	13
6.3	Digital I/O DC Characteristics	14
6.4	PLL and Oscillator DC Characteristics	14
6.5	Analog I/O DC Characteristics	15
6.6	Under Voltage Lockout DC Characteristics	16
6.7	AREF Characteristics	16
7	AC Characteristics	17
7.1	PLL AC Characteristics	17
7.2	Analog to Digital Converter AC Characteristics	18
7.3	Op Amp AC Characteristics	18
7.4	SYNC to SVPWM and A/D Conversion AC Timing	19
7.5	GATEKILL to SVPWM AC Timing	20
7.6	Interrupt AC Timing	20
7.7	I ² C AC Timing	21
7.8	SPI AC Timing	22
7.8.1	SPI Write AC timing	22
7.8.2	SPI Read AC Timing	23
7.9	UART AC Timing	24
7.10	CAPTURE Input AC Timing	25
7.11	JTAG AC Timing	26
7.12	OTP Programming Timing	27
8	I/O Structure	28
9	Pin List	31
10	Package Dimensions	34
11	Part Marking Information	35
12	Order Information	35

TABLE OF FIGURES

Figure 1	Typical Application Block Diagram Using IRMCK343.....	5
Figure 2.	IRMCK343 Internal Block Diagram.....	6
Figure 3.	IRMCK343 Pin Configuration.....	8
Figure 4.	Input/Output of IRMCK343	9
Figure 5.	Application Connection of IRMCK343	12
Figure 6.	Clock Frequency vs. Power Consumption.....	13
Figure 7	Crystal oscillator circuit.....	17
Figure 8	Voltage droop of sample and hold.....	18
Figure 9	SYNC to SVPWM and A/D Conversion AC Timing	19
Figure 10	GATEKILL to SVPWM AC Timing	20
Figure 11	Interrupt AC Timing	20
Figure 12	I ² C AC Timing	21
Figure 13	SPI write AC Timing.....	22
Figure 14	SPI read AC Timing.....	23
Figure 15	UART AC Timing	24
Figure 16	CAPTURE Input AC Timing.....	25
Figure 17	JTAG AC Timing.....	26
Figure 18	OTP Programming Timing.....	27
Figure 19	All digital I/O and motor PWM output.....	28
Figure 20	RESET, GATEKILL I/O	28
Figure 21	Analog input	29
Figure 22	Analog operational amplifier output and AREF I/O structure.....	29
Figure 23	VPP programming pin.....	29
Figure 24	VSS, AVSS and PLLVSS pin structure	30
Figure 25	VDD1, VDD2, AVDD and PLLVDD pin structure	30
Figure 26	XTAL0/XTAL1 pins structure	30

TABLE OF TABLES

Table 1.	Absolute Maximum Ratings	13
Table 2.	System Clock Frequency	13
Table 3.	Digital I/O DC Characteristics	14
Table 4.	PLL DC Characteristics	14
Table 5.	Analog I/O DC Characteristics	15
Table 6.	UVcc DC Characteristics	16
Table 7.	AREF DC Characteristics	16
Table 8.	PLL AC Characteristics.....	17
Table 9.	A/D Converter AC Characteristics	18
Table 10.	Current Sensing OP amp Amp AC Characteristics.....	18
Table 11.	SYNC AC Characteristics	19
Table 12.	GATEKILL to SVPWM AC Timing	20
Table 13.	Interrupt AC Timing.....	20
Table 14.	I ² C AC Timing	21
Table 15.	SPI Write AC Timing	22
Table 16.	SPI Read AC Timing.....	23
Table 17.	UART AC Timing	24
Table 18.	CAPTURE AC Timing	25
Table 19.	JTAG AC Timing	26
Table 20.	OTP Programming Timing	27
Table 21.	Pin List.....	33

1 Overview

IRMCK343 is a new International Rectifier integrated circuit device primarily designed as a one-chip solution for complete inverter controlled appliance motor control applications. Unlike a traditional microcontroller or DSP, the IRMCK343 provides a built-in closed loop sensorless control algorithm using the unique Motion Control Engine (MCE™) for permanent magnet motor. The MCE™ consists of a collection of control elements, motion peripherals, a dedicated motion control sequencer and dual port RAM to map internal signal nodes. IRMCK343 also employs a unique single shunt current reconstruction circuit to eliminate additional analog/digital circuitry and enables a direct shunt resistor interface to the IC. Motion control programming is achieved using a dedicated graphical compiler integrated into the MATLAB/Simulink™ development environment. Sequencing, user interface, host communication, and upper layer control tasks can be implemented in the 8051 high-speed 8-bit microcontroller. The 8051 microcontroller is equipped with a JTAG port to facilitate emulation and debugging tools. Figure 1 shows a typical application schematic using the IRMCK343.

IRMCK343 is intended for volume production purpose and contains 64K bytes of OTP (One Time Programming) ROM, which can be programmed through a JTAG port. For a development purpose use, IRMCF343 contains a 48k byte of RAM in place of program OTP to facilitate an application development work. Both IRMCF343 and IRMCK343 come in the same 64-pin QFP package with identical pin configuration to facilitate PC board layout and transition to mass production

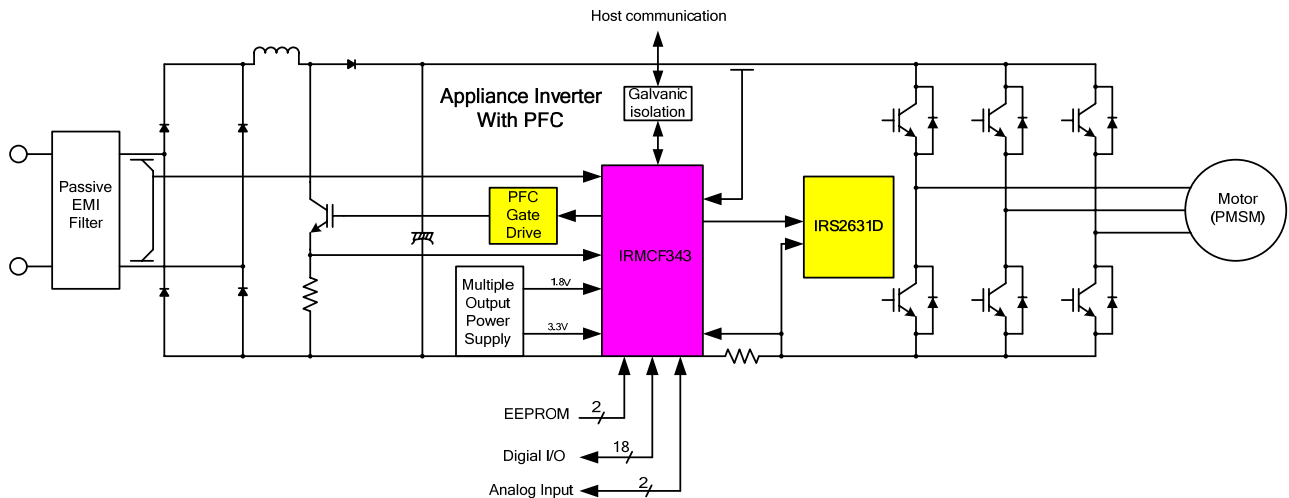

Figure 1 Typical Application Block Diagram Using IRMCK343

2 IRMCK343 Block Diagram and Main Functions

IRMCK343 block diagram is shown in Figure 2.

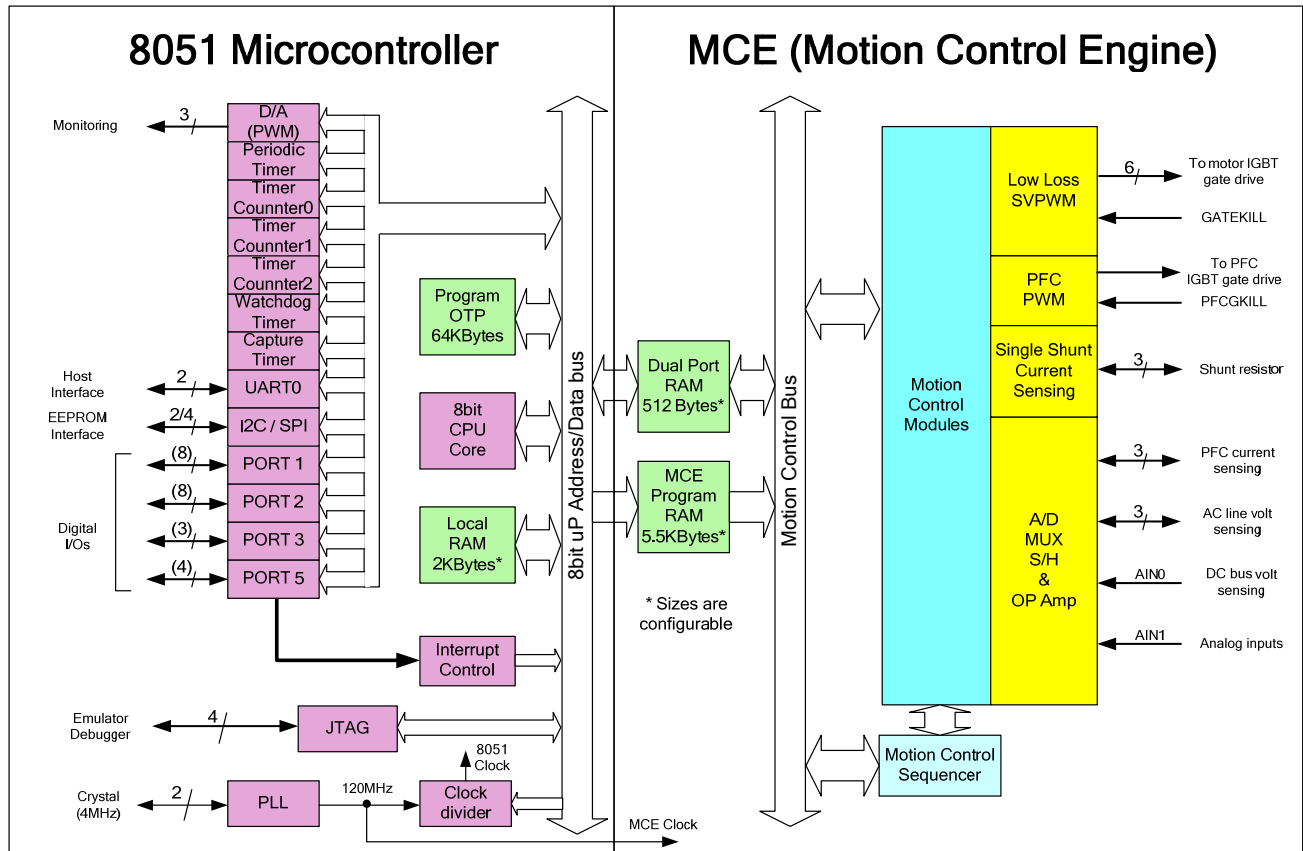

Figure 2. IRMCK343 Internal Block Diagram

IRMCK343 contains the following functions for sensorless AC motor control applications:

- Motion Control Engine (MCE™)
 - Proportional plus Integral block
 - Low pass filter
 - Differentiator and lag (high pass filter)
 - Ramp
 - Limit
 - Angle estimate (sensorless control)
 - Inverse Clark transformation
 - Vector rotator
 - Bit latch
 - Peak detect

- Transition
 - Multiply-divide (signed and unsigned)
 - Divide (signed and unsigned)
 - Adder
 - Subtractor
 - Comparator
 - Counter
 - Accumulator
 - Switch
 - Shift
 - ATAN (arc tangent)
 - Function block (any curve fitting, nonlinear function)
 - 16-bit wide Logic operations (AND, OR, XOR, NOT, NEGATE)
 - MCE™ program and data memory (6K byte). ^{Note 1}
 - MCE™ control sequencer
- 8051 microcontroller
 - Three 16-bit timer/counters
 - 16-bit periodic timer
 - 16-bit analog watchdog timer
 - 16-bit capture timer
 - Up to 23 discrete I/Os
 - Five-channel 12-bit A/D
 - Three buffered channels (0 – 1.2V input)
 - Two unbuffered channels (0 – 1.2V input)
 - JTAG port (4 pins)
 - Up to three channels of analog output (8-bit PWM)
 - UART
 - I²C/SPI port
 - 64K byte program OTP
 - 2K byte data RAM. ^{Note 1}

Note 1: Total size of RAM is 8K byte including MCE program, MCE data, and 8051 data. Different sizes can be allocated depending on applications.

3 Pinout

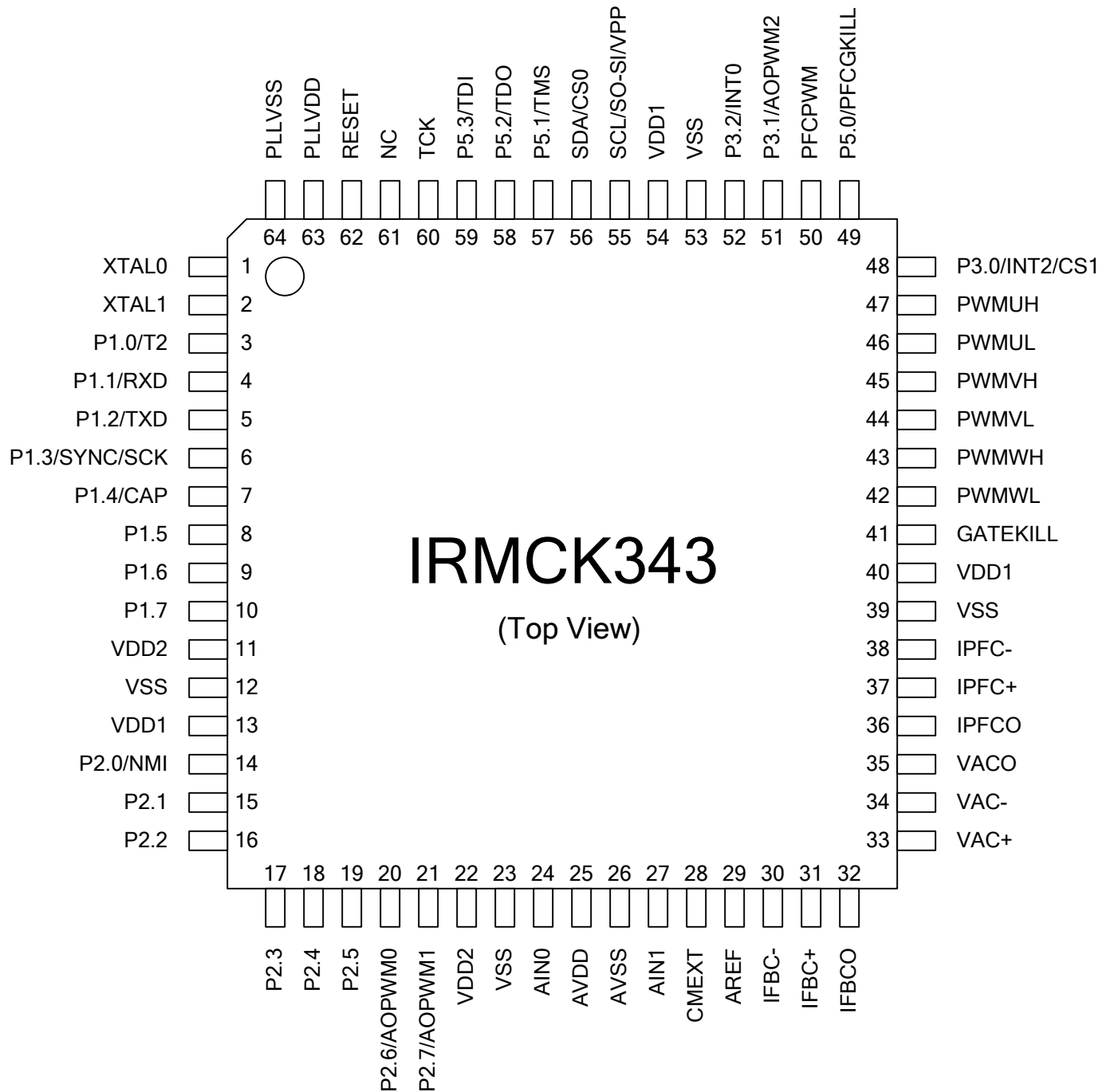

Figure 3. IRMCK343 Pin Configuration

4 Input/Output of IRMCK343

All I/O signals of IRMCK343 are shown in Figure 4. All I/O pins are 3.3V logic interface except A/D interface pins.

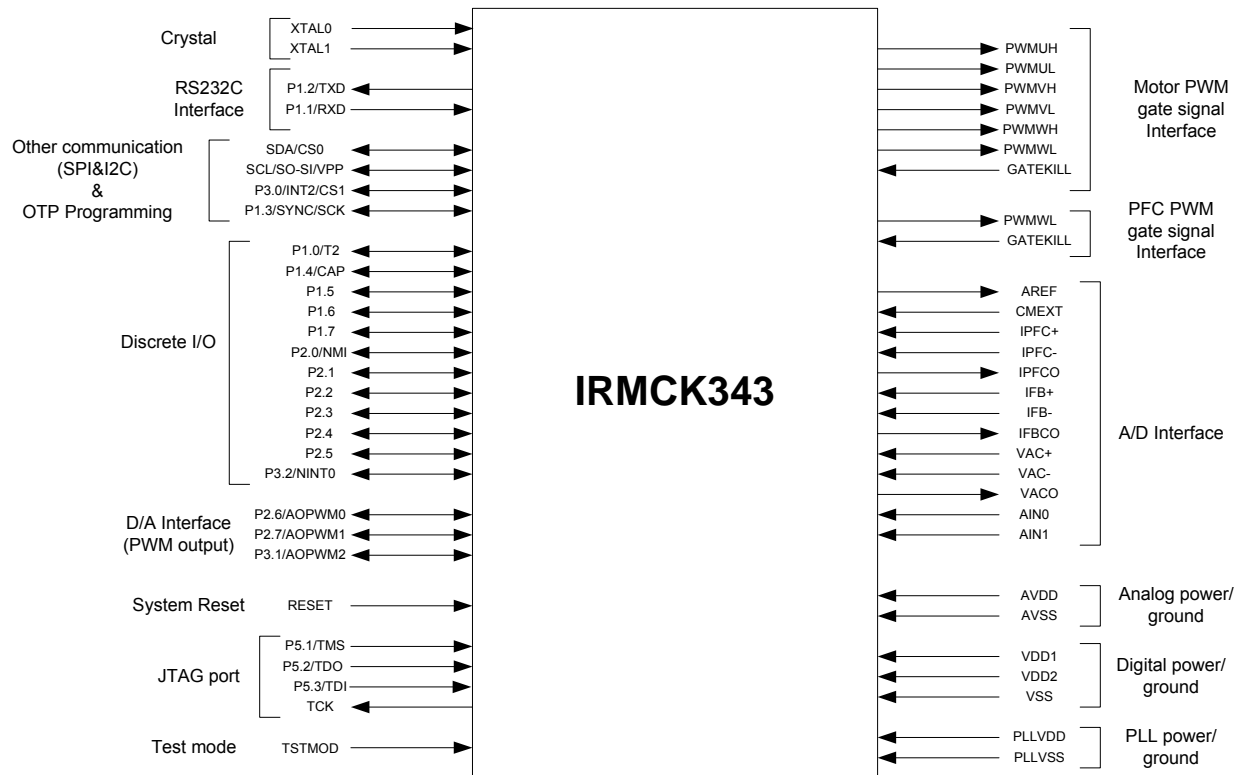

Figure 4. Input/Output of IRMCK343

4.1 8051 Peripheral Interface Group

UART Interface

P1.2/TXD	Output, Transmit data from IRMCK343
P1.1/RXD	Input, Receive data to IRMCK343

Discrete I/O Interface

P1.0/T2	Input/output port 1.0, can be configured as Timer/Counter 2 input
P1.3/SYNC/SCK	Input/output port 1.3, can be configured as SYNC output or SPI clock
P1.4/CAP	Input/output port 1.4, can be configured as Capture Timer input
P1.5	Input/output port 1.5
P1.6	Input/output port 1.6
P1.7	Input/output port 1.7
P2.0/NMI	Input/output port 2.0, can be configured as Non-maskable interrupt input
P2.1	Input/output port 2.1

P2.2	Input/output port 2.2
P2.3	Input/output port 2.3
P2.4	Input/output port 2.4
P2.5	Input/output port 2.5
P3.0/INT2/CS1	Input/output port 3.0, can be configured as INT2 input or SPI chip select 1
P3.2/INT0	Input/output port 3.2, can be configured as INT0 input

Analog Output Interface

P2.6/AOPWM0	Input/output, can be configured as 8-bit PWM output 0 with programmable carrier frequency
P2.7/AOPWM1	Input/output, can be configured as 8-bit PWM output 1 with programmable carrier frequency
P3.1/AOPWM2	Input/output, can be configured as 8-bit PWM output 2 with programmable carrier frequency

Crystal Interface

XTAL0	Input, connected to crystal
XTAL1	Output, connected to crystal

Reset Interface

RESET	Input/output, system reset, needs to be pulled up to VDD1 but doesn't require external RC time constant
-------	---

I²C/SPI Interface/OTP Programming

SCL/SO-SI/VPP	Output or Power, I ² C clock output or SPI data or OTP Programming
SDA/CS0	Input/output, I ² C data line or SPI chip select 0
P3.0/INT2/CS1	Input/output, INT2 or SPI chip select 1
P1.3/SYNC/SCK	Input/output, SYNC output or SPI clock, needs to be pulled up to VDD1 in order to boot from I ² C EEPROM

4.2 Motion Peripheral Interface Group

PWM

PWMUH	Output, PWM phase U high side gate signal
PWMUL	Output, PWM phase U low side gate signal
PWMVH	Output, PWM phase V high side gate signal
PWMVL	Output, PWM phase V low side gate signal
PWMWH	Output, PWM phase W high side gate signal
PWMWL	Output, PWM phase W low side gate signal
PFCPWM	Output, PFC PWM gate signal

Fault

GATEKILL	Input, upon assertion, this negates all six PWM signals, programmable logic sense
P5.0/PFCGKILL	Input, upon assertion, this negates PFCPWM signal, programmable logic sense, can be configured as discrete I/O in which case CGATEKILL negates PFCPWM

4.3 Analog Interface Group

AVDD	Analog power (1.8V)
AVSS	Analog power return
CMEXT	Unbuffered 0.6V, input to the AREF buffer, capacitor needs to be connected.
AREF	0.6V buffered output
IFB+	Input, Operational amplifier positive input for shunt resistor current sensing
IFB-	Input, Operational amplifier negative input for shunt resistor current sensing
IFBO	Output, Operational amplifier output for shunt resistor current sensing
IPFC+	Input, Operational amplifier positive input for PFC current sensing
IPFC-	Input, Operational amplifier negative input for PFC current sensing
IPFO	Output, Operational amplifier output for PFC current sensing
VAC+	Input, Operational amplifier positive input for PFC AC voltage sensing
VAC-	Input, Operational amplifier negative input for PFC AC voltage sensing
VACO	Output, Operational amplifier output for PFC AC voltage sensing
AIN0	Input, Analog input channel 0 (0 – 1.2V), typically configured for DC bus voltage input
AIN1	Input, analog input channel 1 (0 – 1.2V), needs to be pulled down to AVSS if unused

4.4 Power Interface Group

VDD1	Digital power for I/O (3.3V)
VDD2	Digital power for core logic (1.8V)
VSS	Digital common
PLLVD	PLL power (1.8V)
PLLVSS	PLL ground return

4.5 Test Interface Group

TSTMOD	Must be tied to VSS, used only for factory testing.
P5.3/TDI	Input, JTAG test data input
P5.1/TMS	Input, JTAG test mode select
TCK	Input, JTAG test clock
P5.2/TDO	Output, JTAG test data output

5 Application Connections

Typical application connection is shown in Figure 5. All components necessary to implement a complete sensorless drive control algorithm are shown connected to IRMCK343.

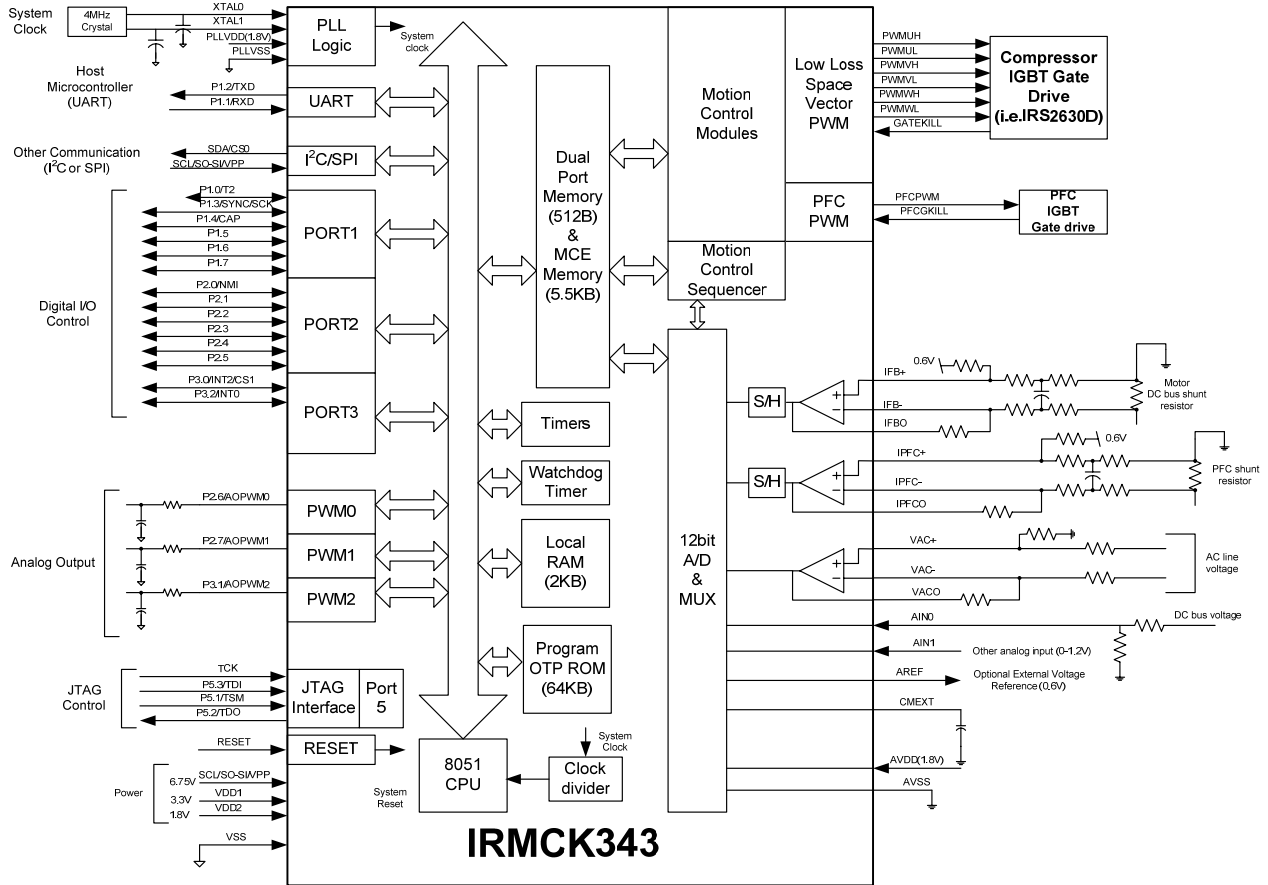

Figure 5. Application Connection of IRMCK343

6 DC Characteristics

6.1 Absolute Maximum Ratings

Symbol	Parameter	Min	Typ	Max	Condition
V _{DD1}	Supply Voltage	-0.3 V	-	3.6 V	Respect to VSS
V _{DD2}	Supply Voltage	-0.3 V	-	1.98 V	Respect to VSS
V _{IA}	Analog Input Voltage	-0.3 V	-	1.98 V	Respect to AVSS
V _{ID}	Digital Input Voltage	-0.3 V	-	3.65 V	Respect to VSS
T _A	Ambient Temperature	-40 °C	-	85 °C	
T _S	Storage Temperature	-65 °C	-	150 °C	

Table 1. Absolute Maximum Ratings

Caution: Stresses beyond those listed in “Absolute Maximum Ratings” may cause permanent damage to the device. These are stress ratings only and function of the device at these or any other conditions beyond those indicated in the operational sections of the specifications are not implied.

6.2 System Clock Frequency and Power Consumption

Symbol	Parameter	Min	Typ	Max	Unit
SYSCLOCK	System Clock	32	-	128	MHz
8051CLK	8051 Clock	-	-	32	MHz

Table 2. System Clock Frequency

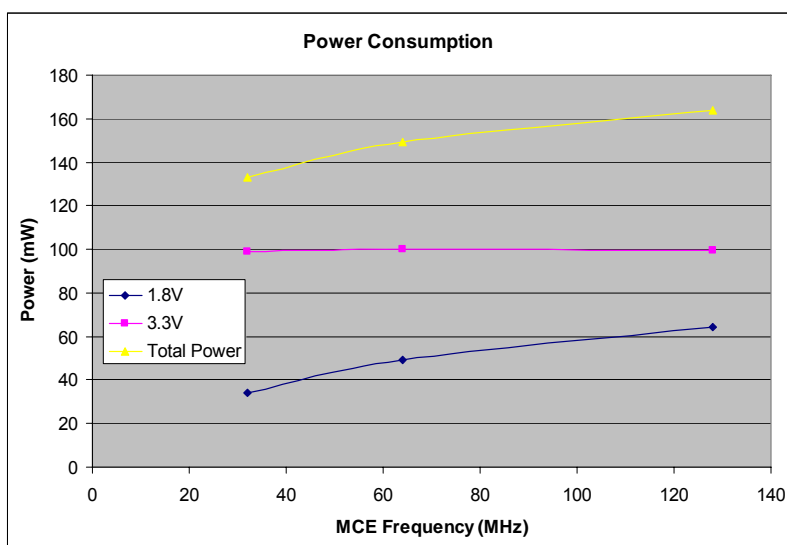

6.3 Digital I/O DC Characteristics

Symbol	Parameter	Min	Typ	Max	Condition
V _{DD1}	Supply Voltage	3.0 V	3.3 V	3.6 V	Recommended
V _{DD2}	Supply Voltage	1.62 V	1.8 V	1.98 V	Recommended
V _{IL}	Input Low Voltage	-0.3 V	-	0.8 V	Recommended
V _{IH}	Input High Voltage	2.0 V		3.6 V	Recommended
C _{IN}	Input capacitance	-	3.6 pF	-	(1)
I _L	Input leakage current		±10 nA	±1 µA	V _O = 3.3 V or 0 V
I _{OL1} ⁽²⁾	Low level output current	8.9 mA	13.2 mA	15.2 mA	V _{OL} = 0.4 V (1)
I _{OH1} ⁽²⁾	High level output current	12.4 mA	24.8 mA	38 mA	V _{OH} = 2.4 V (1)
I _{OL2} ⁽³⁾	Low level output current	17.9 mA	26.3 mA	33.4 mA	V _{OL} = 0.4 V (1)
I _{OH2} ⁽³⁾	High level output current	24.6 mA	49.5 mA	81 mA	V _{OH} = 2.4 V (1)

Table 3. Digital I/O DC Characteristics

Note:

- (1) Data guaranteed by design.
- (2) Applied to SCL/SO-SI, SDA/CS0 pins.
- (3) Applied to P1.0/T2, P1.1/RXD, P1.2/TXD, P1.3/SYNC/SCK, P1.4/CAP, P1.5, P1.6, P1.7, P2.0/NMI, P2.1, P2.2, P2.3, P2.4, P2.5, P2.6/AOPWM0, P2.7/AOPWM1, P3.0/INT2/CS1, P3.1/AOPWM2, P3.2/INT0, P5.0/PFCGKILL, P5.1/TMS, P5.2/TDO, P5.3/TDI, GATEKILL, PWMUL, PWMUH, PWMVL, PWMVH, PWMWL, PWMWH, and PFCPWM pins.

6.4 PLL and Oscillator DC Characteristics

Symbol	Parameter	Min	Typ	Max	Condition
V _{PLLVDD}	Supply Voltage	1.62 V	1.8 V	1.92 V	Recommended
V _{IL OSC}	Oscillator Input Low Voltage	V _{PLLSS}	-	0.2* V _{PLLVDD}	V _{PLLVDD} = 1.8 V (1)
V _{IH OSC}	Oscillator Input High Voltage	0.8* V _{PLLVDD}		V _{PLLVDD}	V _{PLLVDD} = 1.8 V (1)

Table 4. PLL DC Characteristics

Note:

- (1) Data guaranteed by design.

6.5 Analog I/O DC Characteristics

- OP amps for current sensing (IFB+, IFB-, IFBO, IPFC+, IPFC-, IPFCO)

$C_{AREF} = 1nF$, $C_{MEXT} = 100nF$. Unless specified, $T_a = 25^{\circ}C$.

Symbol	Parameter	Min	Typ	Max	Condition
V_{AVDD}	Supply Voltage	1.71 V	1.8 V	1.89 V	Recommended
V_{OFFSET}	Input Offset Voltage	-	-	26 mV	$V_{AVDD} = 1.8 V$
V_I	Input Voltage Range	0 V	-	1.2 V	Recommended
V_{OUTSW}	OP amp output operating range	50 mV ⁽¹⁾	-	1.2 V	$V_{AVDD} = 1.8 V$
C_{IN}	Input capacitance	-	3.6 pF	-	(1)
R_{FDBK}	OP amp feedback resistor	5 k Ω	-	20 k Ω	Requested between op amp output and negative input
OP_{GAINCL}	Operating Close loop Gain	80 db	-	-	(1)
CMRR	Common Mode Rejection Ratio	-	80 db	-	(1)
I_{SRC}	Op amp output source current	-	1 mA	-	$V_{OUT} = 0.6 V$ (1)
I_{SNK}	Op amp output sink current	-	100 μA	-	$V_{OUT} = 0.6 V$ (1)

Table 5. Analog I/O DC Characteristics

Note:

(1) Data guaranteed by design.

6.6 Under Voltage Lockout DC Characteristics

- Based on AVDD (1.8V)

Unless specified, $T_a = 25^\circ\text{C}$.

Symbol	Parameter	Min	Typ	Max	Condition
UV_{CC+}	UVcc positive going Threshold ⁽¹⁾	1.53 V	1.66 V	1.71 V	$V_{DD1} = 3.3\text{ V}$
UV_{CC-}	UVcc negative going Threshold	1.52 V	1.62 V	1.71 V	$V_{DD1} = 3.3\text{ V}$
UV_{CCH}	UVcc Hysteresys	-	40 mV	-	

Table 6. UVcc DC Characteristics

Note:

(1) Data guaranteed by design.

6.7 AREF Characteristics

$C_{AREF} = 1\text{nF}$, $C_{MEXT} = 100\text{nF}$. Unless specified, $T_a = 25^\circ\text{C}$.

Symbol	Parameter	Min	Typ	Max	Condition
V_{AREF}	AREF Output Voltage	495 mV	600 mV	700 mV	$V_{AVDD} = 1.8\text{ V}$
ΔV_o	Load regulation ($V_{DC}-0.6$)	-	1 mV	-	(1)
PSRR	Power Supply Rejection Ratio	-	75 db	-	(1)

Table 7. AREF DC Characteristics

Note:

(1) Data guaranteed by design.

7 AC Characteristics

7.1 PLL AC Characteristics

Symbol	Parameter	Min	Typ	Max	Condition
F _{CLKIN}	Crystal input frequency	3.2 MHz	4 MHz	60 MHz	(1) (see figure below)
F _{PLL}	Internal clock frequency	32 MHz	50 MHz	128 MHz	(1)
F _{LWPW}	Sleep mode output frequency	F _{CLKIN} ÷ 256	-	-	(1)
J _S	Short time jitter	-	200 psec	-	(1)
D	Duty cycle	-	50 %	-	(1)
T _{LOCK}	PLL lock time	-	-	500 μsec	(1)

Table 8. PLL AC Characteristics

Note:

(1) Data guaranteed by design.

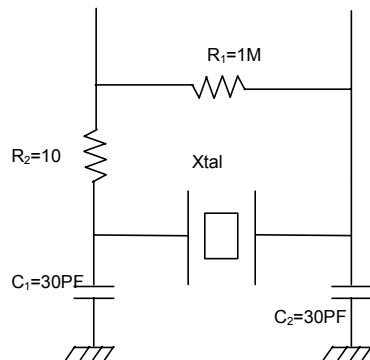

Figure 7 Crystal oscillator circuit

7.2 Analog to Digital Converter AC Characteristics

Unless specified, $T_a = 25^\circ\text{C}$.

Symbol	Parameter	Min	Typ	Max	Condition
T_{CONV}	Conversion time	-	-	2.05 μsec	⁽¹⁾
T_{HOLD}	Sample/Hold maximum hold time	-	-	10 μsec	Voltage droop \leq 15 LSB (see figure below)

Table 9. A/D Converter AC Characteristics

Note:

(1) Data guaranteed by design.

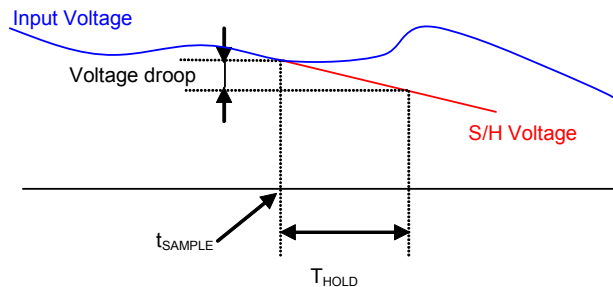

Figure 8 Voltage droop of sample and hold

7.3 Op Amp AC Characteristics

- OP amps for current sensing (IFB+, IFB-, IFBO, IPFC+, IPFC-, IPFCO)

Unless specified, $T_a = 25^\circ\text{C}$.

Symbol	Parameter	Min	Typ	Max	Condition
OP_{SR}	OP amp slew rate	-	10 V/ μsec	-	$V_{\text{AVDD}} = 1.8 \text{ V}$, $CL = 33 \text{ pF}$ ⁽¹⁾
OP_{IMP}	OP input impedance	-	$10^8 \Omega$	-	⁽¹⁾
T_{SET}	Settling time	-	400 ns	-	$V_{\text{AVDD}} = 1.8 \text{ V}$, $CL = 33 \text{ pF}$ ⁽¹⁾

Table 10. Current Sensing OP amp Amp AC Characteristics

Note:

(1) Data guaranteed by design.

7.4 SYNC to SVPWM and A/D Conversion AC Timing

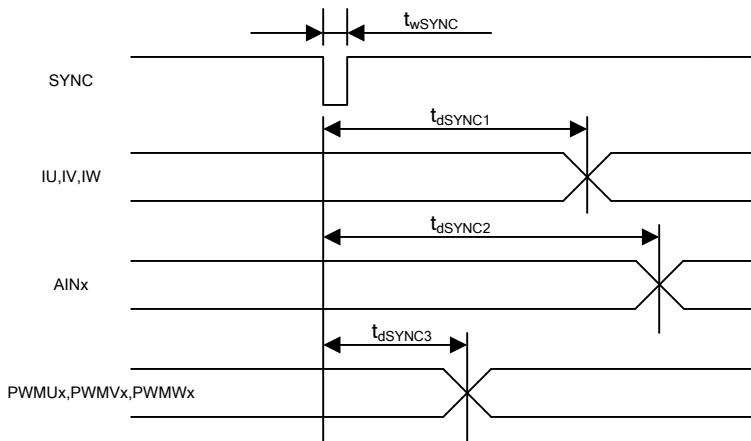

Figure 9 SYNC to SVPWM and A/D Conversion AC Timing

Unless specified, $T_a = 25^\circ\text{C}$.

Symbol	Parameter	Min	Typ	Max	Unit
t_{w_SYNC}	SYNC pulse width	-	32	-	SYSClk
t_{d_SYNC1}	SYNC to current feedback conversion time	-	-	100	SYSClk
t_{d_SYNC2}	SYNC to AIN0-6 analog input conversion time	-	-	200	SYSClk ⁽¹⁾
t_{d_SYNC3}	SYNC to PWM output delay time	-	-	2	SYSClk

Table 11. SYNC AC Characteristics

Note:

(1) AIN1 through AIN6 channels are converted once every 6 SYNC events

7.5 GATEKILL to SVPWM AC Timing

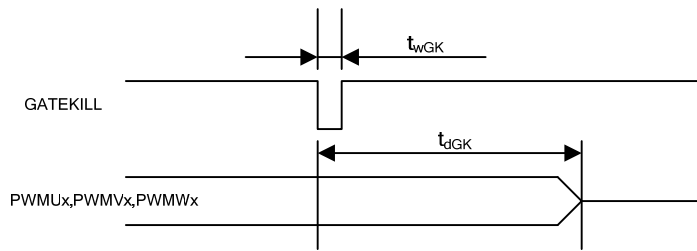

Figure 10 GATEKILL to SVPWM AC Timing

Unless specified, Ta = 25°C.

Symbol	Parameter	Min	Typ	Max	Unit
t_{wGK}	GATEKILL pulse width	32	-	-	SYCLK
t_{dGK}	GATEKILL to PWM output delay	-	-	100	SYCLK

Table 12. GATEKILL to SVPWM AC Timing

7.6 Interrupt AC Timing

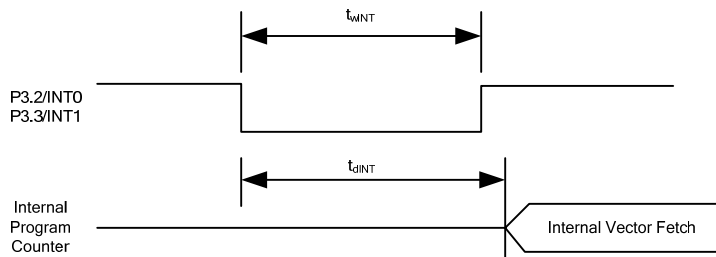

Figure 11 Interrupt AC Timing

Unless specified, Ta = 25°C.

Symbol	Parameter	Min	Typ	Max	Unit
t_{wINT}	INT0, INT1 Interrupt Assertion Time	4	-	-	SYCLK
t_{dINT}	INT0, INT1 latency	-	-	4	SYCLK

Table 13. Interrupt AC Timing

7.7 I²C AC Timing

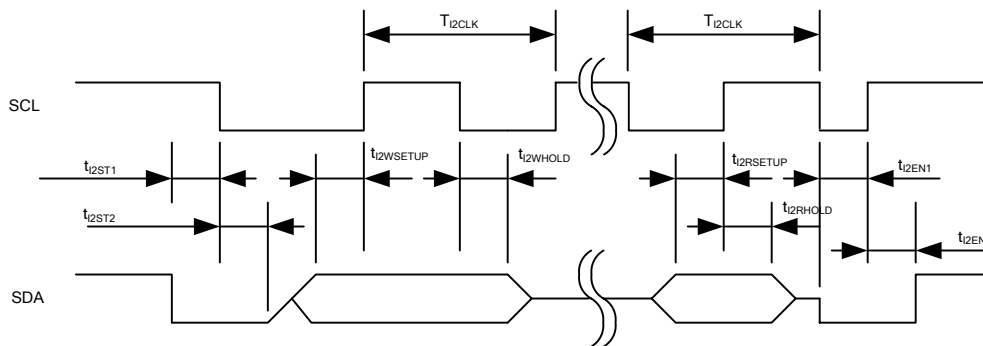

Figure 12 I²C AC Timing

Unless specified, Ta = 25°C.

Symbol	Parameter	Min	Typ	Max	Unit
T _{I2CLK}	I ² C clock period	10	-	8192	SYCLK
t _{I2ST1}	I ² C SDA start time	0.25	-	-	T _{I2CLK}
t _{I2ST2}	I ² C SCL start time	0.25	-	-	T _{I2CLK}
t _{I2WSETUP}	I ² C write setup time	0.25	-	-	T _{I2CLK}
t _{I2WHOLD}	I ² C write hold time	0.25	-	-	T _{I2CLK}
t _{I2RSETUP}	I ² C read setup time	I ² C filter time ⁽¹⁾	-	-	SYCLK
t _{I2RHOLD}	I ² C read hold time	1	-	-	SYCLK

Table 14. I²C AC Timing

Note:

- (1) I²C read setup time is determined by the programmable filter time applied to I²C communication.

7.8 SPI AC Timing

7.8.1 SPI Write AC timing

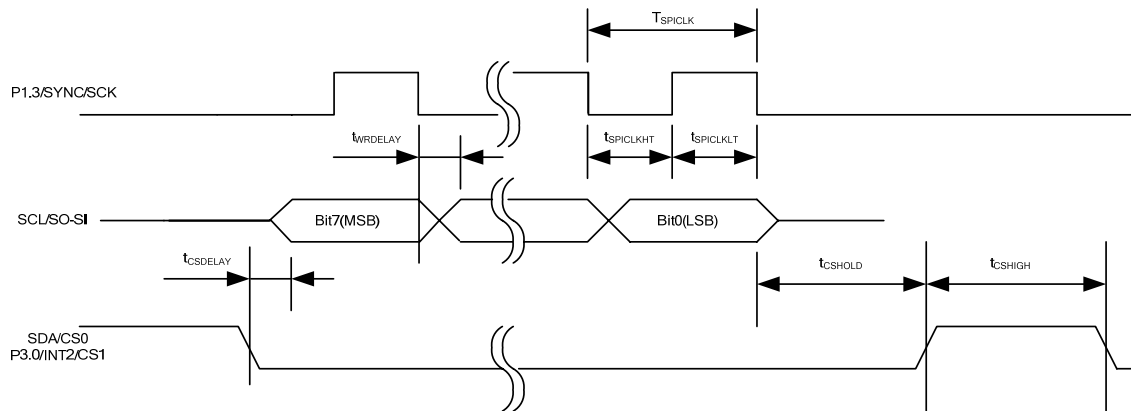

Figure 13 SPI write AC Timing

Unless specified, $T_a = 25^\circ\text{C}$.

Symbol	Parameter	Min	Typ	Max	Unit
T_{SPICLK}	SPI clock period	4	-	-	SYSCLK
t_{SPICLKHT}	SPI clock high time	-	1/2	-	T_{SPICLK}
t_{SPICLKLT}	SPI clock low time	-	1/2	-	T_{SPICLK}
t_{CSDELAY}	CS to data delay time	-	-	10	nsec
t_{WRDELAY}	CLK falling edge to data delay time	-	-	10	nsec
t_{CSHIGH}	CS high time between two consecutive byte transfer	1	-	-	T_{SPICLK}
t_{CSHOLD}	CS hold time	-	1	-	T_{SPICLK}

Table 15. SPI Write AC Timing

7.8.2 SPI Read AC Timing

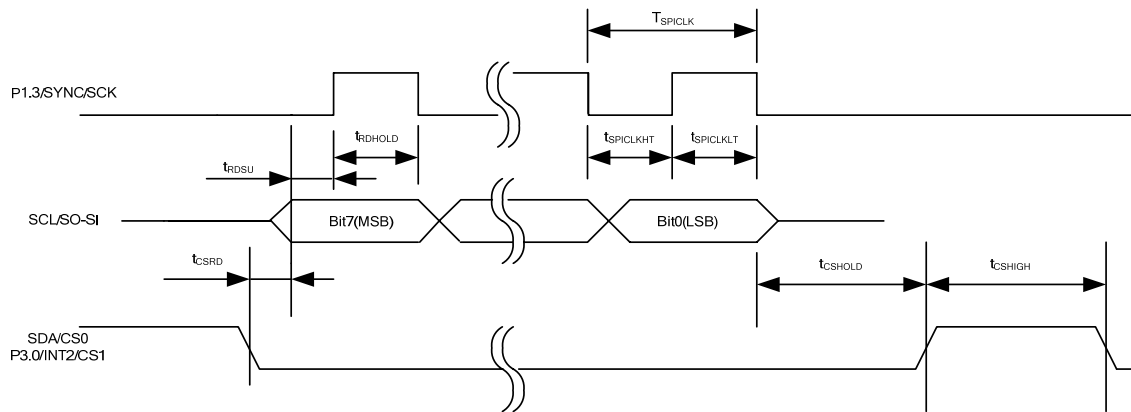

Figure 14 SPI read AC Timing

Unless specified, Ta = 25°C.

Symbol	Parameter	Min	Typ	Max	Unit
T _{SPICLK}	SPI clock period	4	-	-	SYSCLK
t _{SPICLKHT}	SPI clock high time	-	1/2	-	T _{SPICLK}
t _{SPICLKLT}	SPI clock low time	-	1/2	-	T _{SPICLK}
t _{CSRd}	CS to data delay time	-	-	10	nsec
t _{RDSU}	SPI read data setup time	10	-	-	nsec
t _{RDHOLD}	SPI read data hold time	10	-	-	nsec
t _{CSHIGH}	CS high time between two consecutive byte transfer	1	-	-	T _{SPICLK}
t _{CSHOLD}	CS hold time	-	1	-	T _{SPICLK}

Table 16. SPI Read AC Timing

7.9 UART AC Timing

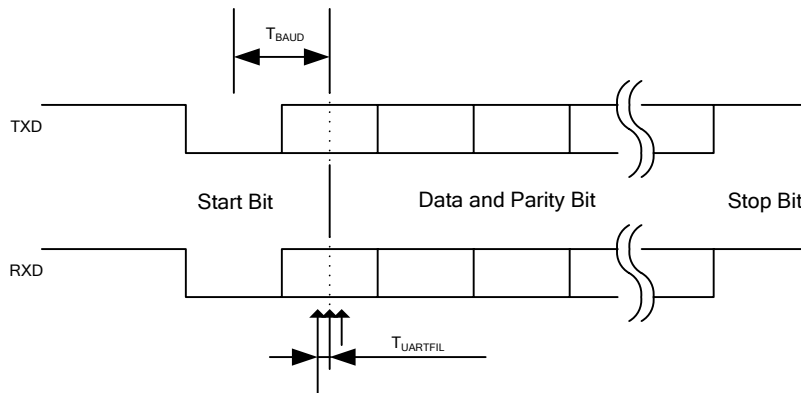

Figure 15 UART AC Timing

Unless specified, $T_a = 25^\circ\text{C}$.

Symbol	Parameter	Min	Typ	Max	Unit
T_{BAUD}	Baud Rate Period	-	57600	-	bit/sec
$T_{UARTFIL}$	UART sampling filter period ⁽¹⁾	-	1/16	-	T_{BAUD}

Table 17. UART AC Timing

Note:

- (1) Each bit including start and stop bit is sampled three times at center of a bit at an interval of $1/16 T_{BAUD}$. If three sampled values do not agree, then UART noise error is generated.

7.10 CAPTURE Input AC Timing

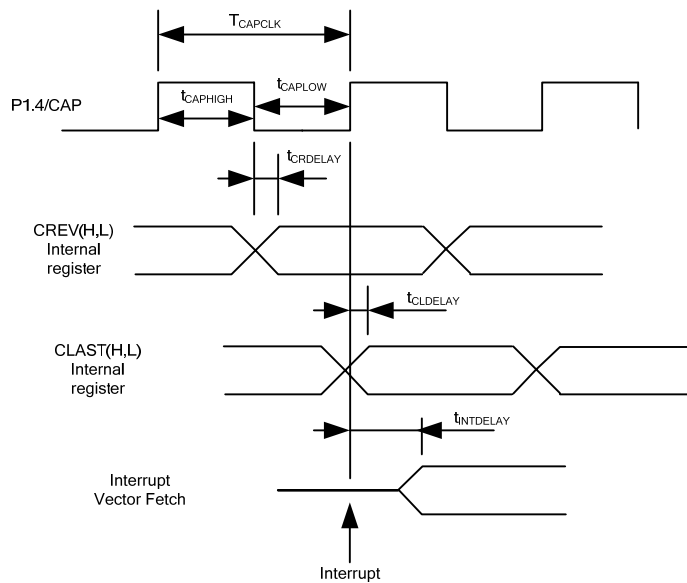

Figure 16 CAPTURE Input AC Timing

Unless specified, $T_a = 25^\circ\text{C}$.

Symbol	Parameter	Min	Typ	Max	Unit
T_{CAPCLK}	CAPTURE input period	8	-	-	SYSCLK
$t_{CAPHIGH}$	CAPTURE input high time	4	-	-	SYSCLK
t_{CAPLOW}	CAPTURE input low time	4	-	-	SYSCLK
$t_{CRDELAY}$	CAPTURE falling edge to capture register latch time	-	-	4	SYSCLK
$t_{CLDELAY}$	CAPTURE rising edge to capture register latch time	-	-	4	SYSCLK
$t_{INTDELAY}$	CAPTURE input interrupt latency time	-	-	4	SYSCLK

Table 18. CAPTURE AC Timing

7.11 JTAG AC Timing

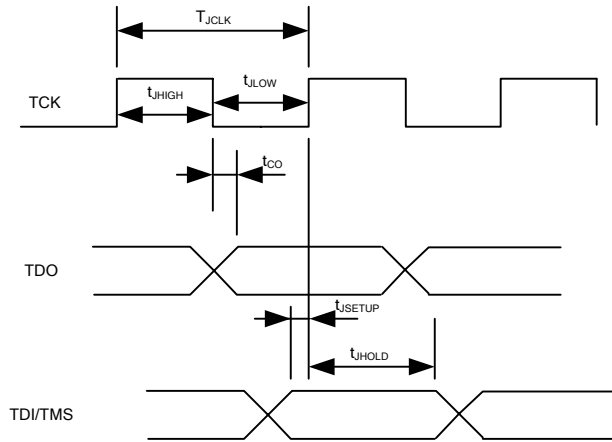

Figure 17 JTAG AC Timing

Unless specified, $T_a = 25^\circ\text{C}$.

Symbol	Parameter	Min	Typ	Max	Unit
T_{JCLK}	TCK Period	-	-	50	MHz
t_{JHIGH}	TCK High Period	10	-	-	nsec
t_{JLOW}	TCK Low Period	10	-	-	nsec
t_{CO}	TCK to TDO propagation delay time	0	-	5	nsec
t_{JSETUP}	TDI/TMS setup time	4	-	-	nsec
t_{JHOLD}	TDI/TMS hold time	0	-	-	nsec

Table 19. JTAG AC Timing

7.12 OTP Programming Timing

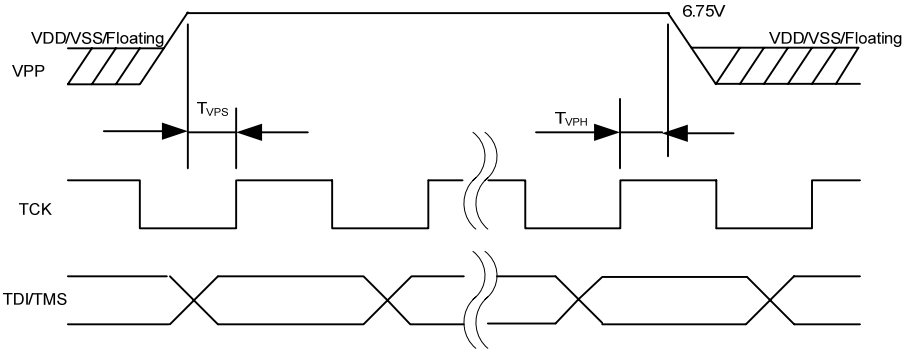

Figure 18 OTP Programming Timing

Unless specified, $T_a = 25^\circ\text{C}$.

Symbol	Parameter	Min	Typ	Max	Unit
T_{VPS}	VPP Setup Time	10	-	-	nsec
T_{VPH}	VPP Hold Time	15	-	-	nsec

Table 20. OTP Programming Timing

8 I/O Structure

The following figure shows the motor PWM and digital I/O structure

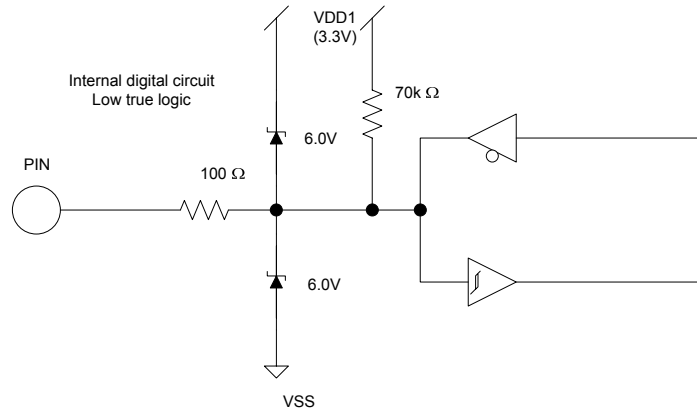

Figure 19 All digital I/O and motor PWM output

The following figure shows RESET and GATEKILL I/O structure.

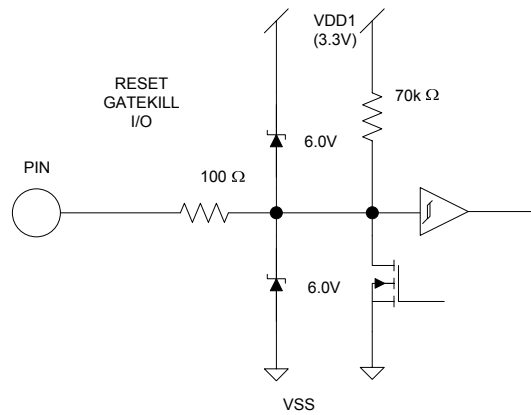

Figure 20 RESET, GATEKILL I/O

The following figure shows the analog input structure.

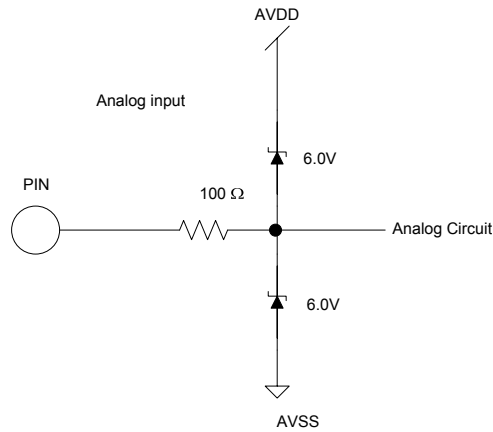

Figure 21 Analog input

The following figure shows all analog operational amplifier output pins and AREF pin I/O structure.

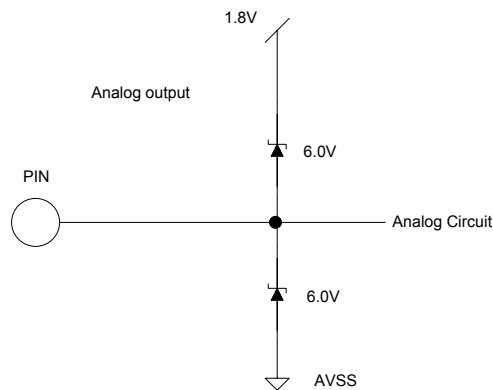

Figure 22 Analog operational amplifier output and AREF I/O structure

The following figure shows the VPP pin I/O structure

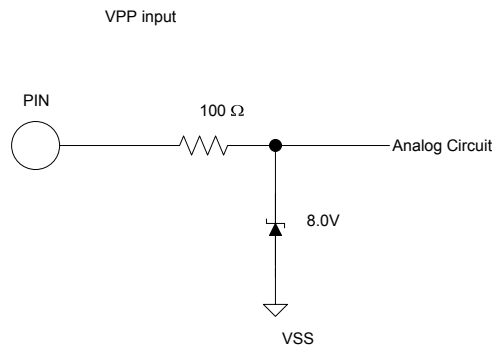

Figure 23 VPP programming pin

The following figure shows the VSS, AVSS and PLLVSS pin structure

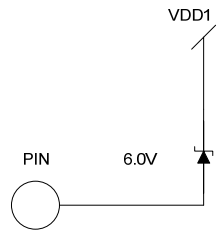

Figure 24 VSS, AVSS and PLLVSS pin structure

The following figure shows the VDD1, VDD2, AVDD and PLLVDD pin structure

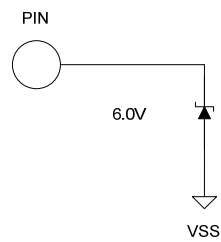

Figure 25 VDD1, VDD2, AVDD and PLLVDD pin structure

The following figure shows the XTAL0 and XTAL1 pins structure

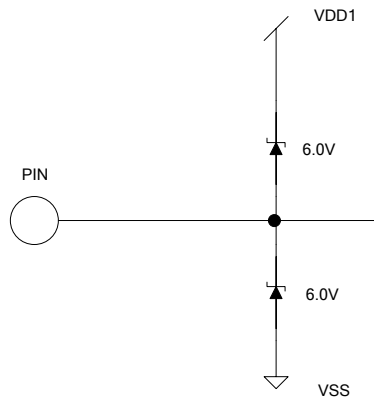

Figure 26 XTAL0/XTAL1 pins structure

9 Pin List

Pin Number	Pin Name	Internal IC Pull-up /Pull-down	Pin Type	Description
1	XTAL0		I	Crystal input
2	XTAL1		O	Crystal output
3	P1.0/T2		I/O	Discrete programmable I/O or Timer/Counter 2 input
4	P1.1/RXD		I/O	Discrete programmable I/O or UART receive input
5	P1.2/TXD		I/O	Discrete programmable I/O or UART transmit output
6	P1.3/SYNC/SCK		I/O	Discrete programmable I/O or SYNC output or SPI clock
7	P1.4/CAP		I/O	Discrete programmable I/O or Capture Timer input
8	P1.5		I/O	Discrete programmable I/O
9	P1.6		I/O	Discrete programmable I/O
10	P1.7		I/O	Discrete programmable I/O
11	VDD2		P	1.8V digital power
12	VSS		P	Digital common
13	VDD1		P	3.3V digital power
14	P2.0/NMI		I/O	Discrete programmable I/O or Non-maskable Interrupt input
15	P2.1		I/O	Discrete programmable I/O
16	P2.2		I/O	Discrete programmable I/O
17	P2.3		I/O	Discrete programmable I/O
18	P2.4		I/O	Discrete programmable I/O
19	P2.5		I/O	Discrete programmable I/O
20	P2.6/AOPWM0		I/O	Discrete programmable I/O or PWM 0 output
21	P2.7/AOPWM1		I/O	Discrete programmable I/O or PWM 1 output
22	VDD2		P	1.8V digital power
23	VSS		P	Digital common
24	AIN0		I	Analog input channel 0, 0-1.2V range, needs to be pulled down to AVSS if unused
25	AVDD		P	1.8V analog power
26	AVSS		P	Analog common
27	AIN1		I	Analog input channel 1, 0-1.2V range, needs to be pulled down to AVSS if unused
28	CMEXT		O	Unbuffered 0.6V output. Capacitor needs to be connected.
29	AREF		O	Analog reference voltage output (0.6V)
30	IFB-		I	Single shunt current sensing OP amp input (-)
31	IFB+		I	Single shunt current sensing OP amp input (+)

Pin Number	Pin Name	Internal IC Pull-up /Pull-down	Pin Type	Description
32	IFBO		O	Single shunt current sensing OP amp output
33	VAC+		I	AC input voltage sensing OP amp input (+)
34	VAC-		I	AC input voltage sensing OP amp input (-)
35	VACO		O	AC input voltage sensing OP amp output
36	IFPCO		O	PFC shunt current sensing OP amp output
37	IFPC+		I	PFC shunt current sensing OP amp input (+)
38	IFPC-		I	PFC shunt current sensing OP amp input (-)
39	VSS		P	Digital common
40	VDD1		P	3.3V digital power
41	GATEKILL		I	PWM shutdown input, 2- μ sec digital filter, configurable either high or low true.
42	PWMWL	70 k Ω Pull up	O	PWM gate drive for phase W low side, configurable either high or low true
43	PWMWH	70 k Ω Pull up	O	PWM gate drive for phase W high side, configurable either high or low true
44	PWMVL	70 k Ω Pull up	O	PWM gate drive for phase V low side, configurable either high or low true
45	PWMVH	70 k Ω Pull up	O	PWM gate drive for phase V high side, configurable either high or low true
46	PWMUL	70 k Ω Pull up	O	PWM gate drive for phase U low side, configurable either high or low true
47	PWMUH	70 k Ω Pull up	O	PWM gate drive for phase U high side, configurable either high or low true
48	P3.0/INT2/ CS1		I/O	Discrete programmable I/O or external interrupt 2 input or SPI chip select 1
49	P5.0/ PFCGKILL		I/O	Discrete programmable I/O or PFC PWM shutdown input, 2- μ sec digital filter, configurable either high or low true.
50	PFCPWM		O	PFC PWM output
51	P3.1/ AOPWM2		I/O	Discrete programmable I/O or PWM analog output 2
52	P3.2/INT0		I/O	Discrete programmable I/O or Interrupt 0 input
53	VSS		P	Digital common
54	VDD1		P	3.3V digital power
55	SCL/ SO-SI/VPP		I/O P	I ² C clock output (open drain, need pull up) or SPI data or OTP Programming
56	SDA/CS0		I/O	I ² C data (open drain, need pull up) or SPI chip select 0
57	P5.1/TMS		I/O	Discrete programmable I/O or JTAG test mode select
58	P5.2/TDO		I/O	Discrete programmable I/O or JTAG test data output
59	P5.3/TDI		I/O	Discrete programmable I/O or JTAG test data input
60	TCK		I	JTAG test clock

Pin Number	Pin Name	Internal IC Pull-up /Pull-down	Pin Type	Description
61	TSTMOD	58 k Ω pull down	I	Test mode. Must be tied to VSS. Factory use only
62	RESET		I/O	Reset, low true, Schmitt trigger input
63	PLLVDD		P	1.8V PLL power
64	PLLVSS		P	PLL ground

Table 21. Pin List

10 Package Dimensions

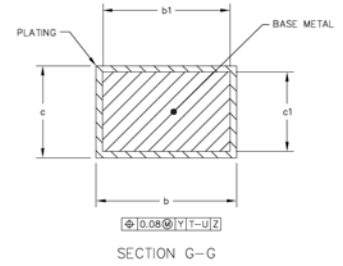
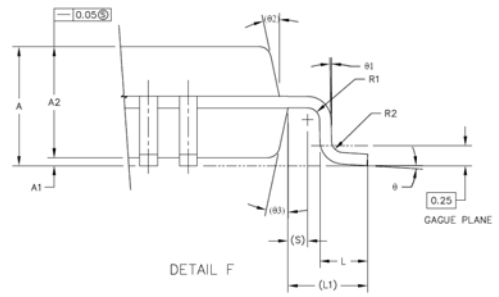
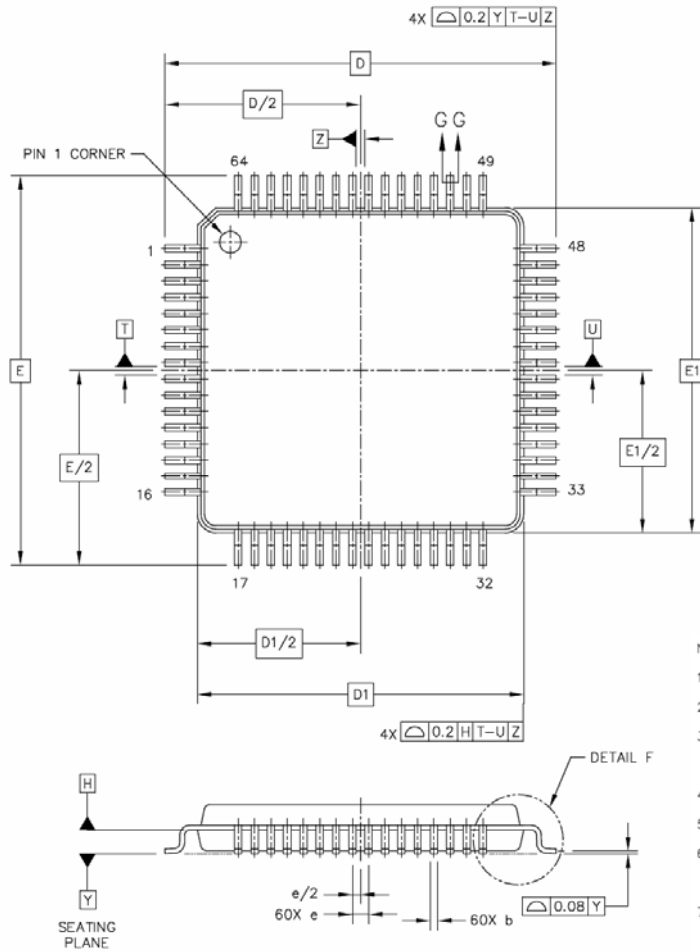

- NOTES:
1. DIMENSIONS ARE IN MILLIMETERS.
 2. INTERPRET DIMENSIONS AND TOLERANCES PER ASME Y14.5M-1994.
 3. DATUM PLANE DATUM H IS LOCATED AT BOTTOM OF LEAD AND IS COINCIDENT WITH THE LEAD WHERE THE LEAD EXITS THE PLASTIC BODY AT THE BOTTOM OF THE PARTING LINE.
 4. DATUM T, U, AND Z TO BE DETERMINED AT DATUM PLANE H.
 5. DIMENSIONS D AND E TO BE DETERMINED AT SEATING PLANE DATUM Y.
 6. DIMENSIONS D1 AND E1 DO NOT INCLUDE MOLD PROTRUSION. ALLOWABLE PROTRUSION IS 0.25 PER SIDE. DIMENSIONS D1 AND E1 DO INCLUDE MOLD MISMATCH AND ARE DETERMINED AT DATUM PLANE DATUM H.
 7. DIMENSION b DOES NOT INCLUDE DAMBAR PROTRUSION. DAMBAR PROTRUSION SHALL NOT CAUSE THE b DIMENSION TO EXCEED 0.35. MINIMUM SPACE BETWEEN PROTRUSION AND ADJACENT LEAD OR PROTRUSION 0.07.

DIM	MIN	MAX	DIM	MIN	MAX	DIM	MIN	MAX
A	---	1.6	L1	1 REF				
A1	0.05	0.15	R1	0.1	0.2			
A2	1.35	1.45	R2	0.1	0.2			
b	0.17	0.27	S	0.2 REF				
b1	0.17	0.23	θ	0°	7°			
c	0.09	0.2	θ1	0°	---			
c1	0.09	0.16	θ2	12° REF				
D		12 BSC	θ3	12° REF				
D1		10 BSC						
e		0.5 BSC						
E		12 BSC						
E1		10 BSC						
L	0.45	0.75						

11 Part Marking Information

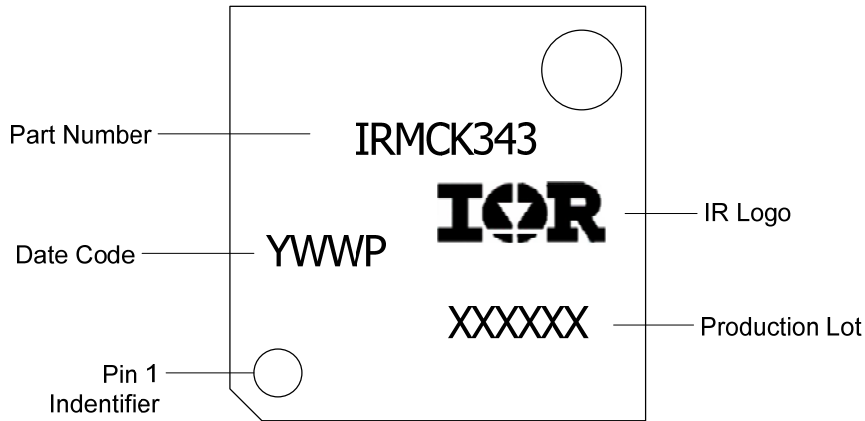

12 Order Information

Lead-Free Part in 64-lead QFP
Moisture Sensitivity Rating – MSL3

Part number	Order quantities
IRMCK343TR	1500 parts on tape and reel in dry pack
IRMCK343TY	1600 parts on trays (160 parts per tray) in dry pack

International
IR Rectifier

The LQFP-64 is MSL3 qualified
 This product has been designed and qualified for the industrial level
 Qualification standards can be found at www.irf.com <<http://www.irf.com>>
IR WORLD HEADQUARTERS: 233 Kansas St., El Segundo, California 90245, Tel: (310) 252-7105
 Data and specifications subject to change without notice. 12/25/2007

Компания «Life Electronics» занимается поставками электронных компонентов импортного и отечественного производства от производителей и со складов крупных дистрибьюторов Европы, Америки и Азии.

С конца 2013 года компания активно расширяет линейку поставок компонентов по направлению коаксиальный кабель, кварцевые генераторы и конденсаторы (керамические, пленочные, электролитические), за счёт заключения дистрибьюторских договоров

Мы предлагаем:

- Конкуренеспособные цены и скидки постоянным клиентам.
- Специальные условия для постоянных клиентов.
- Подбор аналогов.
- Поставку компонентов в любых объемах, удовлетворяющих вашим потребностям.
- Приемлемые сроки поставки, возможна ускоренная поставка.
- Доставку товара в любую точку России и стран СНГ.
- Комплексную поставку.
- Работу по проектам и поставку образцов.
- Формирование склада под заказчика.
- Сертификаты соответствия на поставляемую продукцию (по желанию клиента).
- Тестирование поставляемой продукции.
- Поставку компонентов, требующих военную и космическую приемку.
- Входной контроль качества.
- Наличие сертификата ISO.

В составе нашей компании организован Конструкторский отдел, призванный помогать разработчикам, и инженерам.

Конструкторский отдел помогает осуществить:

- Регистрацию проекта у производителя компонентов.
- Техническую поддержку проекта.
- Защиту от снятия компонента с производства.
- Оценку стоимости проекта по компонентам.
- Изготовление тестовой платы монтаж и пусконаладочные работы.



Тел: +7 (812) 336 43 04 (многоканальный)

Email: org@lifeelectronics.ru