

## GENERAL DESCRIPTION

The 83947I is a low skew, 1-to-9 LVCMOS Fanout Buffer. The low impedance LVCMOS/LVTTL outputs are designed to drive 50Ω series or parallel terminated transmission lines. The effective fanout can be increased from 9 to 18 by utilizing the ability of the outputs to drive two series terminated lines.

Guaranteed output and part-to-part skew characteristics make the 83947I ideal for high performance, single ended applications that also require a limited output voltage.

## FEATURES

- 9 LVCMOS/LVTTL outputs
- Selectable CLK0 and CLK1 can accept the following input levels: LVCMOS and LVTTL
- Maximum output frequency: 110MHz
- Output skew: 500ps (maximum)
- Part-to-part skew: 2ns (maximum)
- 3.3V operating supply
- -40°C to 85°C ambient operating temperature
- Lead-Free package available

## BLOCK DIAGRAM

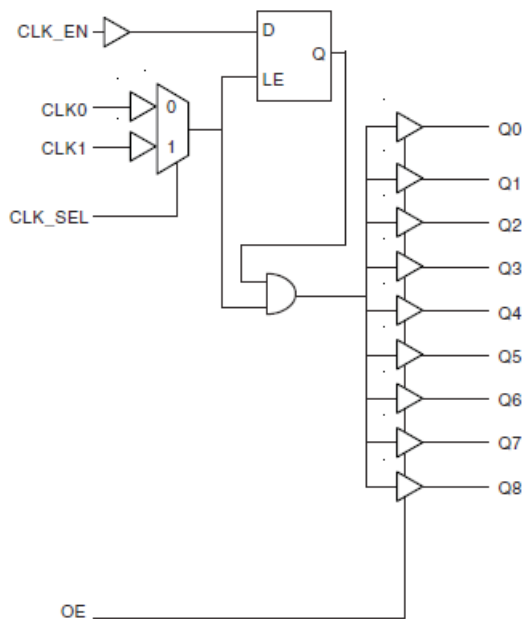

## PIN ASSIGNMENT

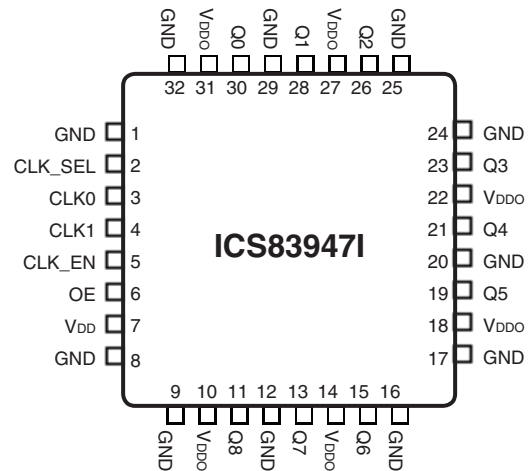

**32-Lead LQFP**  
7mm x 7mm x 1.4mm package body  
**Y Package**  
Top View

**TABLE 1. PIN DESCRIPTIONS**

Number	Name	Type		Description
1, 8, 9, 12, 16, 17, 20, 24, 25, 29, 32	GND	Power		Power supply ground.
2	CLK_SEL	Input	Pullup	Clock select input. When HIGH, selects CLK1. When LOW, selects CLK0. LVCMOS / LVTTTL interface levels.
3, 4	CLK0, CLK1	Input	Pullup	Reference clock inputs. LVCMOS / LVTTTL interface levels.
5	CLK_EN	Input	Pullup	Clock enable. LVCMOS / LVTTTL interface levels.
6	OE	Input	Pullup	Output enable. LVCMOS / LVTTTL interface levels.
7	V <sub>DD</sub>	Power		Core supply pin.
10, 14, 18, 22, 27, 31	V <sub>DDO</sub>	Power		Output supply pins.
11, 13, 15, 19, 21, 23, 26, 28, 30	Q8, Q7, Q6, Q5, Q4, Q3, Q2, Q1, Q0	Output		Q0 thru Q8 clock outputs. LVCMOS / LVTTTL interface levels.

NOTE: *Pullup* refers to internal input resistors. See Table 2, Pin Characteristics, for typical values.

**TABLE 2. PIN CHARACTERISTICS**

Symbol	Parameter	Test Conditions	Minimum	Typical	Maximum	Units
C <sub>IN</sub>	Input Capacitance			4		pF
C <sub>PD</sub>	Power Dissipation Capacitance (per output)			25		pF
R <sub>PULLUP</sub>	Input Pullup Resistor			51		KΩ
R <sub>PULLDOWN</sub>	Input Pulldown Resistor			51		KΩ
R <sub>OUT</sub>	Output Impedance		5	7	12	Ω

**TABLE 3. OUTPUT ENABLE AND CLOCK ENABLE FUNCTION TABLE**

Control Inputs		Output
OE	CLK_EN	Q0:Q8
0	X	Hi-Z
1	0	LOW
1	1	Follows CLK input

**ABSOLUTE MAXIMUM RATINGS**

Supply Voltage, $V_{DD}$	4.6V
Inputs, $V_I$	-0.5V to $V_{DD} + 0.5V$
Outputs, $V_O$	-0.5V to $V_{DDO} + 0.5V$
Package Thermal Impedance, $\theta_{JA}$	47.9°C/W (0 lfm)
Storage Temperature, $T_{STG}$	-65°C to 150°C

NOTE: Stresses beyond those listed under Absolute Maximum Ratings may cause permanent damage to the device. These ratings are stress specifications only. Functional operation of product at these conditions or any conditions beyond those listed in the *DC Characteristics* or *AC Characteristics* is not implied. Exposure to absolute maximum rating conditions for extended periods may affect product reliability.

**TABLE 4A. POWER SUPPLY DC CHARACTERISTICS,  $V_{DD} = V_{DDO} = 3.3V \pm 0.3V$ ,  $T_A = -40^\circ\text{C}$  TO  $85^\circ\text{C}$** 

Symbol	Parameter	Test Conditions	Minimum	Typical	Maximum	Units
$V_{DD}$	Coret Supply Voltage		3.0	3.3	3.6	V
$V_{DDO}$	Output Supply Voltage		3.0	3.3	3.6	V
$I_{DD}$	Input Supply Current			33	50	mA

**TABLE 4B. LVCMOS/LVTTL DC CHARACTERISTICS,  $V_{DD} = V_{DDO} = 3.3V \pm 0.3V$ ,  $T_A = -40^\circ\text{C}$  TO  $85^\circ\text{C}$** 

Symbol	Parameter	Test Conditions	Minimum	Typical	Maximum	Units
$V_{IH}$	Input High Voltage		2		3.6	V
$V_{IL}$	Input Low Voltage				0.8	V
$I_{IN}$	Input Current	CLK0, CLK1, CLK_SEL, OE, CLK_EN	-100			$\mu\text{A}$
$V_{OH}$	Output High Voltage	$I_{OH} = -20\text{mA}$	2.5			V
$V_{OL}$	Output Low Voltage	$I_{OL} = 20\text{mA}$			0.4	V

**TABLE 5. AC CHARACTERISTICS,  $V_{DD} = V_{DDO} = 3.3V \pm 0.3V$ ,  $T_A = -40^{\circ}C$  TO  $85^{\circ}C$** 

Symbol	Parameter	Test Conditions	Minimum	Typical	Maximum	Units
$f_{MAX}$	Output Frequency		110			MHz
$t_{PD}$	Propagation Delay, NOTE 1	CLK to Q	1.8		4.5	ns
tsk(o)	Output Skew; NOTE 2, 5	Measured on rising edge @ $V_{DDO}/2$			500	ps
tsk(pp)	Part-to-Part Skew; NOTE 3, 5	Measured on rising edge @ $V_{DDO}/2$			2	ns
$t_{PW}$	Output Pulse Width		tPeriod/2 - 800		tPeriod/2 + 800	ps
$t_S$	Clock Enable Setup Time; NOTE 6	CLK_EN to CLK	0			ns
$t_H$	Clock Enable Hold Time; NOTE 6	CLK_EN to CLK	1			ns
$t_{ZL}, t_{ZH}$	Output Enable Time; NOTE 4				11	ns
$t_{LZ}, t_{HZ}$	Output Disable Time; NOTE 4				11	ns
$t_R$	Output Rise Time	0.8V to 2.0V	0.2		1	ns
$t_F$	Output Fall Time	0.8V to 2.0V	0.2		1	ns

All parameters measured at  $f_{MAX}$  unless noted otherwise.

NOTE 1: Measured from  $V_{DD}/2$  of the input to  $V_{DDO}/2$  of the output.

NOTE 2: Defined as skew between outputs at the same supply voltage and with equal load conditions.

Measured at  $V_{DDO}/2$ .

NOTE 3: Defined as skew between outputs on different devices operating at the same supply voltages and with equal load conditions. Using the same type of inputs on each device, the outputs are measured at  $V_{DDO}/2$ .

NOTE 4: These parameters are guaranteed by characterization. Not tested in production.

NOTE 5: This parameter is defined in accordance with JEDEC Standard 65.

NOTE 6: Setup and Hold times are relative to the rising edge of the input clock.

## PARAMETER MEASUREMENT INFORMATION

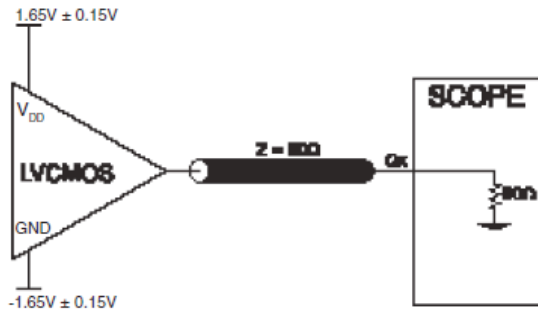
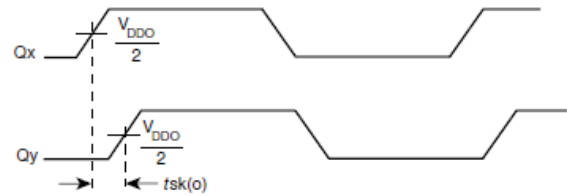
**3.3V OUTPUT LOAD AC TEST CIRCUIT**

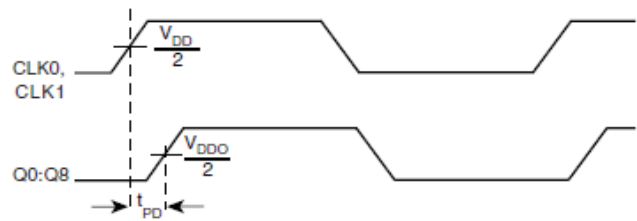
**OUTPUT SKEW**

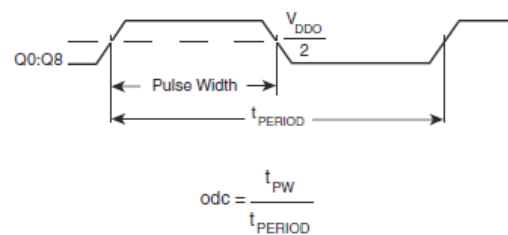
**PART-TO-PART SKEW**

**PROPAGATION DELAY**

**OUTPUT RISE/FALL TIME**

**OUTPUT DUTY CYCLE/PULSE WIDTH/PERIOD**

## RELIABILITY INFORMATION

**TABLE 6.  $\theta_{JA}$  VS. AIR FLOW TABLE FOR 32 LEAD LQFP**

$\theta_{JA}$ by Velocity (Linear Feet per Minute)			
	<b>0</b>	<b>200</b>	<b>500</b>
Single-Layer PCB, JEDEC Standard Test Boards	67.8°C/W	55.9°C/W	50.1°C/W
Multi-Layer PCB, JEDEC Standard Test Boards	47.9°C/W	42.1°C/W	39.4°C/W

**NOTE:** Most modern PCB designs use multi-layered boards. The data in the second row pertains to most designs.

### TRANSISTOR COUNT

The transistor count for 83947I is: 1040

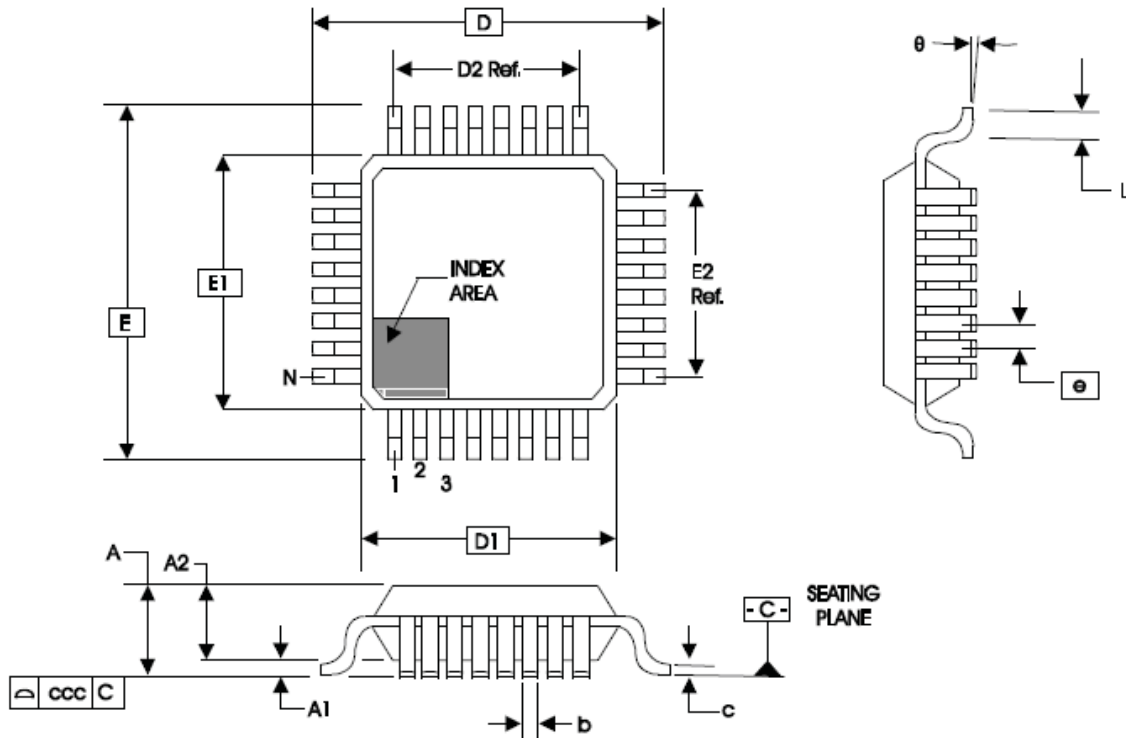
**PACKAGE OUTLINE - Y SUFFIX FOR 32 LEAD LQFP**

**TABLE 7. PACKAGE DIMENSIONS**

JEDEC VARIATION ALL DIMENSIONS IN MILLIMETERS			
SYMBOL	BBA		
	MINIMUM	NOMINAL	MAXIMUM
N	32		
A	--	--	1.60
A1	0.05	--	0.15
A2	1.35	1.40	1.45
b	0.30	0.37	0.45
c	0.09	--	0.20
D	9.00 BASIC		
D1	7.00 BASIC		
D2	5.60 Ref.		
E	9.00 BASIC		
E1	7.00 BASIC		
E2	5.60 Ref.		
e	0.80 BASIC		
L	0.45	0.60	0.75
$\theta$	0°	--	7°
ccc	--	--	0.10

Reference Document: JEDEC Publication 95, MS-026

**TABLE 8. ORDERING INFORMATION**

<b>Part/Order Number</b>	<b>Marking</b>	<b>Package</b>	<b>Shipping Packaging</b>	<b>Temperature</b>
83947AYILN	ICS3947AYIN	32 Lead "Lead-Free/Annealed" LQFP	tray	-40°C to 85°C
83947AYILNT	ICS3947AYIN	32 Lead "Lead-Free/Annealed" LQFP	Tape & Reel	-40°C to 85°C



REVISION HISTORY SHEET				
Rev	Table	Page	Description of Change	Date
A	T5	4	AC Characteristics Table, $t_s$ and $t_H$ rows- revised Test Conditions to read CLK_EN to CLK.	6/21/02
B	T2	1	Added Lead Free bullet in Features section.	10/11/04
		2	Pin Characteristics Table - changed $C_{IN}$ from 4pF max. to 4pF min. $R_{OUT}$ added 5 $\Omega$ min and 12 $\Omega$ max.	
	T8	8	Ordering Information Table - add Lead-Free part. Updated format throughout data sheet.	
B	T8	8	Updated datasheet's header/footer with IDT from ICS.	8/9/10
		10	Removed ICS prefix from Part/Order Number column. Added Contact Page.	
B	T8	8	Updated datasheet format Ordering information - removed leaded part numbers - PDN CQ-13-02 expired	11/10/14
B			Removed ICS from part number where needed. Updated header and footer.	3/17/16



Corporate Headquarters  
6024 Silver Creek Valley Road  
San Jose, CA 95138 USA  
[www.IDT.com](http://www.IDT.com)

Sales  
1-800-345-7015 or 408-284-8200  
Fax: 408-284-2775  
[www.IDT.com/go/sales](http://www.IDT.com/go/sales)

Tech Support  
[www.idt.com/go/support](http://www.idt.com/go/support)

DISCLAIMER Integrated Device Technology, Inc. (IDT) reserves the right to modify the products and/or specifications described herein at any time, without notice, at IDT's sole discretion. Performance specifications and operating parameters of the described products are determined in an independent state and are not guaranteed to perform the same way when installed in customer products. The information contained herein is provided without representation or warranty of any kind, whether express or implied, including, but not limited to, the suitability of IDT's products for any particular purpose, an implied warranty of merchantability, or non-infringement of the intellectual property rights of others. This document is presented only as a guide and does not convey any license under intellectual property rights of IDT or any third parties.

IDT's products are not intended for use in applications involving extreme environmental conditions or in life support systems or similar devices where the failure or malfunction of an IDT product can be reasonably expected to significantly affect the health or safety of users. Anyone using an IDT product in such a manner does so at their own risk, absent an express, written agreement by IDT.

Integrated Device Technology, IDT and the IDT logo are trademarks or registered trademarks of IDT and its subsidiaries in the United States and other countries. Other trademarks used herein are the property of IDT or their respective third party owners.

For datasheet type definitions and a glossary of common terms, visit [www.idt.com/go/glossary](http://www.idt.com/go/glossary).

Copyright ©2016 Integrated Device Technology, Inc. All rights reserved.

Компания «Life Electronics» занимается поставками электронных компонентов импортного и отечественного производства от производителей и со складов крупных дистрибьюторов Европы, Америки и Азии.

С конца 2013 года компания активно расширяет линейку поставок компонентов по направлению коаксиальный кабель, кварцевые генераторы и конденсаторы (керамические, пленочные, электролитические), за счёт заключения дистрибьюторских договоров

Мы предлагаем:

- Конкурентоспособные цены и скидки постоянным клиентам.
- Специальные условия для постоянных клиентов.
- Подбор аналогов.
- Поставку компонентов в любых объемах, удовлетворяющих вашим потребностям.
- Приемлемые сроки поставки, возможна ускоренная поставка.
- Доставку товара в любую точку России и стран СНГ.
- Комплексную поставку.
- Работу по проектам и поставку образцов.
- Формирование склада под заказчика.
- Сертификаты соответствия на поставляемую продукцию (по желанию клиента).
- Тестирование поставляемой продукции.
- Поставку компонентов, требующих военную и космическую приемку.
- Входной контроль качества.
- Наличие сертификата ISO.

В составе нашей компании организован Конструкторский отдел, призванный помогать разработчикам, и инженерам.

Конструкторский отдел помогает осуществить:

- Регистрацию проекта у производителя компонентов.
- Техническую поддержку проекта.
- Защиту от снятия компонента с производства.
- Оценку стоимости проекта по компонентам.
- Изготовление тестовой платы монтаж и пусконаладочные работы.



Тел: +7 (812) 336 43 04 (многоканальный)  
Email: [org@lifeelectronics.ru](mailto:org@lifeelectronics.ru)