

# Digilent PmodDA2™ Digital To Analog Module Converter Board Reference Manual



www.digilentinc.com

Revision: September 25, 2006

215 E Main Suite D | Pullman, WA 99163  
(509) 334 6306 Voice and Fax

## Overview

The Digilent PmodDA2 Digital to Analog Module Converter, converts signals from digital values to analog voltages on two channels simultaneously with twelve bits of resolution. The PmodDA2 uses a 6-pin header connector and, at less than one square inch, is small enough to be located where the reconstructed signal is required.

Features include:

- two National Semiconductor DAC121S101, 12-bit D/A converters
- a 6-pin header and 6-pin connector
- two simultaneous D/A conversion channels
- very low power consumption
- small form factor (0.80" x 0.80").

## Functional Description

The PmodDA2 can produce an analog output ranging from 0-3.3 volts when operated with a 3.3V power supply. It has two simultaneous D/A conversion channels, each with a 12-bit converter that can process separate digital signals.

The PmodDA2 is equipped with two DAC121S101 digital to analog converters. Sending commands via the SPI/MICROWIRE™ serial bus to the D/A converters produces outputs. The two converters are connected in parallel so that commands are sent to both converters simultaneously.

The PmodDA2 is designed to work with either Digilent programmable logic system boards or embedded control system boards. Most Digilent system boards, such as the Nexys, Basys, or Cerebot, have 6-pin



**Figure 1**  
**Digilent PmodDA2**

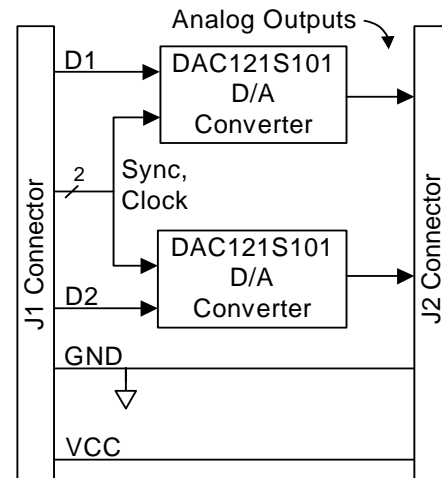

**Figure 2**  
**Block Diagram**

connectors that allow the PmodDA2 to plug directly into the system board or to connect via a Digilent six-wire cable

Some older Digilent boards may need a Digilent Module Interface Board (MIB) and a 6-pin cable to connect to the PmodDA2. The MIB plugs into the system board and the cable connects the MIB to the PmodDA2.

See Table 1 for a description of the signals on the interface connectors J1 and J2. For additional information, refer to the PmodDA2 schematic available on the Digilent web site at [www.digilentinc.com](http://www.digilentinc.com).

The PmodDA2 is usually powered from the Digilent system board connected to it. The power and ground connections are on pins five and six of the digital interface connector J1. Alternatively, the PmodDA2 can be powered from an external power supply provided through pins five and six of the analog interface connector J2. In this case the power select jumper on the system board should be set to disconnect power from the system board to J1. Damage may result if two power supplies are connected at the same time.

The Digilent convention is to provide 3.3V to power Pmod modules. The PmodDA2 can be operated at any power supply voltage between 2.7V and 5.5V, however caution should be exercised if using any voltage greater than 3.3V, as damage to the Digilent system board could result. For more information refer to reference manuals or schematics for the system board available at [www.digilentinc.com](http://www.digilentinc.com).

For detailed information about the National Semiconductor data sheet refer to the National Semiconductor web site at [www.national.com](http://www.national.com).

**Table 1: Interface Connector Signal Descriptions**

<b>Digital Interface – J1</b>	
1	SYNC (common)
2	DINA (converter IC1)
3	DINB (converter IC2)
4	SCLK (common)
5	GND
6	VCC
<b>Analog Interface – J2</b>	
1	VOUTA (converter IC1)
2	N/C
3	VOUTB (converter IC2)
4	N/C
5	GND
6	VCC

Компания «Life Electronics» занимается поставками электронных компонентов импортного и отечественного производства от производителей и со складов крупных дистрибьюторов Европы, Америки и Азии.

С конца 2013 года компания активно расширяет линейку поставок компонентов по направлению коаксиальный кабель, кварцевые генераторы и конденсаторы (керамические, пленочные, электролитические), за счёт заключения дистрибьюторских договоров

Мы предлагаем:

- Конкурентоспособные цены и скидки постоянным клиентам.
- Специальные условия для постоянных клиентов.
- Подбор аналогов.
- Поставку компонентов в любых объемах, удовлетворяющих вашим потребностям.
- Приемлемые сроки поставки, возможна ускоренная поставка.
- Доставку товара в любую точку России и стран СНГ.
- Комплексную поставку.
- Работу по проектам и поставку образцов.
- Формирование склада под заказчика.
- Сертификаты соответствия на поставляемую продукцию (по желанию клиента).
- Тестирование поставляемой продукции.
- Поставку компонентов, требующих военную и космическую приемку.
- Входной контроль качества.
- Наличие сертификата ISO.

В составе нашей компании организован Конструкторский отдел, призванный помогать разработчикам, и инженерам.

Конструкторский отдел помогает осуществить:

- Регистрацию проекта у производителя компонентов.
- Техническую поддержку проекта.
- Защиту от снятия компонента с производства.
- Оценку стоимости проекта по компонентам.
- Изготовление тестовой платы монтаж и пусконаладочные работы.



Тел: +7 (812) 336 43 04 (многоканальный)

Email: [org@lifeelectronics.ru](mailto:org@lifeelectronics.ru)