

# 2.7V 1F, 100F, 150F ULTRACAPACITOR CELL

## FEATURES AND BENEFITS\*

- Up to 500,000 duty cycles or 10 year life
- Low internal resistance
- High power density
- 1F to 150F capacitance range
- -40° to 85°C operating temperature range

## APPLICATIONS

- Back-up power for cache-to-flash applications
- Smart meters
- Automotive subsystems
- Consumer and industrial electronics
- Wireless transmitters

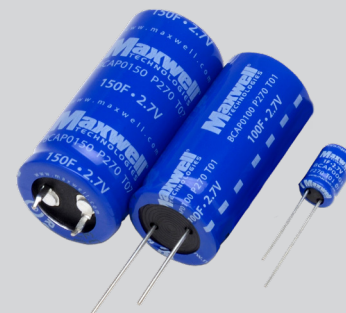

## PRODUCT SPECIFICATIONS

ELECTRICAL	BCAP0001	BCAP0100 T01	BCAP0150
Rated Capacitance	1 F	100 F	150 F
Minimum Capacitance, initial <sup>3</sup>	0.8 F	100 F	150 F
Maximum ESR <sub>DC</sub> , initial <sup>3</sup>	700 mΩ	15 mΩ	14 mΩ
Test Current for Capacitance and ESR <sub>DC</sub> <sup>3</sup>	0.1 A	10 A	15 A
Rated Voltage (65°/85°C)	2.70 / 2.30 V	2.70 / 2.30 V	2.70 / 2.30 V
Absolute Maximum Voltage <sup>1</sup>	2.85 V	2.85 V	2.85 V
Absolute Maximum Current <sup>5</sup>	0.8 A	36 A	40 A
Leakage Current at 25°C, maximum <sup>4</sup>	0.006 mA	0.260 mA	0.500 mA

## TEMPERATURE

Operating temperature range  
(Cell case temperature)

Minimum	-40°C	-40°C	-40°C
Maximum	65° / 85°C	65° / 85°C	65° / 85°C

Storage temperature range  
(Stored uncharged)

Minimum	-40°C	-40°C	-40°C
Maximum	70°C	70°C	70°C

## PHYSICAL

Mass, typical	1.1 g	23 g	32 g
Terminals	Wire Leads	Wire Leads	Snap in
Vibration	-	-	-
Shock	-	-	-

\*Results may vary. Additional terms and conditions, including the limited warranty, apply at the time of purchase. See the warranty details for applicable operating and use requirements.

## PRODUCT SPECIFICATIONS

### POWER & ENERGY AT 2.7V

	BCAP0001	BCAP0100 T01	BCAP0150
Usable Specific Power, $P_d^6$	1,100 W/kg	2,500 W/kg	2,000 W/kg
Impedance Match Specific Power, $P_{max}^6$	2,400 W/kg	5,300 W/kg	4,100 W/kg
Specific Energy, $E_{max}^6$	0.9 Wh/kg	4.4 Wh/kg	4.7 Wh/kg
Stored Energy, $E_{stored}^{6,9}$	0.001 Wh	0.101 Wh	0.152 Wh

### SAFETY

Short Circuit Current, typical <sup>2</sup> (Current possible with short circuit from rated voltage. Do not use as an operating current.)	4 A	180 A	190 A
Certifications	UL810a, RoHS	UL810a, RoHS	UL810a, RoHS

## TYPICAL CHARACTERISTICS

### THERMAL

Thermal Resistance ( $R_{ca}$ , Case to Ambient), typical <sup>2,8</sup>	120°C/W	22°C/W	18°C/W
Thermal Capacitance ( $C_{th}$ ), typical <sup>2</sup>	1.0 J/°C	23 J/°C	32
Maximum Continuous Current ( $\Delta T = 15^\circ C$ ) <sup>8,10</sup> (BOL)	0.4 A <sub>RMS</sub>	6.7 A <sub>RMS</sub>	7.7 A <sub>RMS</sub>
Maximum Continuous Current ( $\Delta T = 40^\circ C$ ) <sup>8,10</sup> (BOL)	0.7 A <sub>RMS</sub>	11 A <sub>RMS</sub>	13 A <sub>RMS</sub>

### LIFE\*

<b>DC Life at High Temperature</b> <sup>3,10</sup> (held continuously at Rated Voltage & Maximum Operating Temperature)	1,000 hours	1,000 hours	1,000 hours
Capacitance Change (% decrease from minimum initial value)	30%	30%	30%
ESR Change (% increase from maximum initial value)	100%	100%	100%
<b>Projected DC Life at 25°C</b> <sup>3,10</sup> (at Rated Voltage & 25°C)	10 years	10 years	10 years
Capacitance Change (% decrease from minimum initial value)	30%	30%	30%
ESR Change (% increase from maximum initial value)	100%	100%	100%
<b>Projected Cycle Life at 25°C</b> <sup>3,7,10</sup>	500,000 cycles	500,000 cycles	500,000 cycles
Capacitance Change (% decrease from minimum initial value)	30%	30%	30%
ESR Change (% increase from maximum initial value)	100%	100%	100%
Test Current	0.1 A	10 A	15 A
<b>Shelf Life</b> (Stored uncharged at 25°C, <50% RH)	2 years	2 years	2 years

\*Results may vary. Additional terms and conditions, including the limited warranty, apply at the time of purchase. See the warranty details for applicable operating and use requirements.

# Datasheet: 2.7V 1F, 100F, 150F ULTRACAPACITOR CELL

1. Surge Voltage  
Absolute maximum voltage, non-repetitive. Duration not to exceed 1 second.

2. "Typical" values represent mean values of production sample.

3. Rated Capacitance & ESR<sub>DC</sub> (measure method)

- Capacitance: Constant current charge (per datasheet) to V<sub>R</sub>, 5 min hold at V<sub>R</sub>, constant current discharge 10 mA/F to 0.1V.

- ESR<sub>DC</sub>: Constant current charge (per datasheet) to V<sub>R</sub>, 5 min hold at V<sub>R</sub>, constant current discharge (40 \* C \* V<sub>R</sub>[mA]) to 0.1 V.

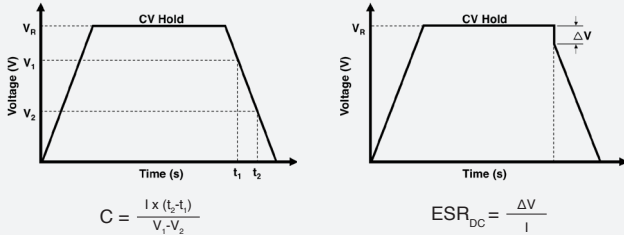

where C is the capacitance (F);

I is the absolute value of the discharge current (A);

V<sub>R</sub> is the rated voltage (V);

V<sub>1</sub> is the measurement start voltage, 0.8xV<sub>R</sub> (V);

V<sub>2</sub> is the measurement end voltage, 0.4xV<sub>R</sub> (V);

t<sub>1</sub> is the time from start of discharge to reach V<sub>1</sub> (s);

t<sub>2</sub> is the time from start of discharge to reach V<sub>2</sub> (s);

ESR<sub>DC</sub> is the DC-ESR (Ω);

ΔV is the voltage drop during first 10ms of discharge (V).

Typical ESR<sub>DC</sub>, Initial, 5 sec tested per Maxwell Application Note, "Test Procedures for Capacitance, ESR, Leakage Current and Self-Discharge Characterizations of Ultracapacitors" available at [www.maxwell.com](http://www.maxwell.com).

4. Maximum Leakage Current

- Current measured after 72 hrs at rated voltage and 25°C. Initial leakage current can be higher.
- If applicable, module leakage current is the sum of cell and balancing circuit leakage currents.

5. Maximum Peak Current

- Current needed to discharge cell/module from rated voltage to half-rated voltage in 1 second.

$$I = \frac{\frac{1}{2}V_R}{\Delta t / C + ESR_{DC}}$$

where Δt is the discharge time (sec); Δt = 1 sec in this case.

- The stated maximum peak current should not be used in normal operation and is only provided as a reference value.

6. Energy & Power (Based on IEC 62391-2)

- Maximum Stored Energy, E<sub>max</sub> (Wh) =  $\frac{\frac{1}{2}CV_R^2}{3,600}$

- Gravimetric Specific Energy (Wh/kg) =  $\frac{E_{max}}{mass}$

- Usable Specific Power (W/kg) =  $\frac{0.12V_R^2}{ESR_{DC} \times mass}$

- Impedance Match Specific Power (W/kg) =  $\frac{0.25V_R^2}{ESR_{DC} \times mass}$

- Presented Power and Energy values are calculated based on Rated Capacitance & Rated (Max.) ESR<sub>DC</sub>, Initial values.

7. Cycle Life Test Profile

Cycle life varies depending upon application-specific characteristics. Actual results will vary.

8. Temperature Rise at Constant Current

- ΔT = I<sub>RMS</sub><sup>2</sup> x ESR<sub>DC</sub> x R<sub>th</sub>

where ΔT: Temperature rise over ambient (°C)

I<sub>RMS</sub>: Maximum continuous or RMS current (A)

R<sub>th</sub>: Thermal resistance, cell to ambient (°C/W)

ESR<sub>DC</sub>: Rated (Max.) ESR<sub>DC</sub> (Ω).

(Note: Design should consider EOL ESR<sub>DC</sub> for application temperature rise evaluation.)

9. Per United Nations material classification UN3499, all Maxwell ultracapacitors have less than 10 Wh capacity to meet the requirements of Special Provisions 361. Both individual ultracapacitors and modules composed of those ultracapacitors shipped by Maxwell can be transported without being treated as dangerous goods (hazardous materials) under transportation regulations.

10. BOL: Beginning of Life, rated initial product performance

EOL: End of Life criteria.

- Capacitance: 80% of min. BOL rating

- ESR<sub>DC</sub>: 2x max. BOL rating

## BCAP0001,100 (T01)

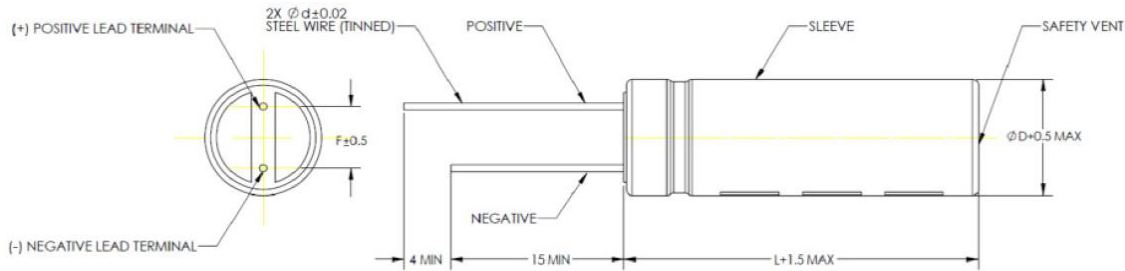

Product dimensions are for reference only unless otherwise identified. Product dimensions and specifications may change without notice. Please contact Maxwell Technologies directly for any technical specifications critical to application.

Part Description	Dimensions (mm)							Package Quantity
	L	D	d	F	R	a	b	
BCAP0001 P270 T01	12	8	0.6	3.8	-	-	-	4,000
BCAP0100 P270 T01	45	22	1	9.5	-	-	-	400

## BCAP0150 (T07)

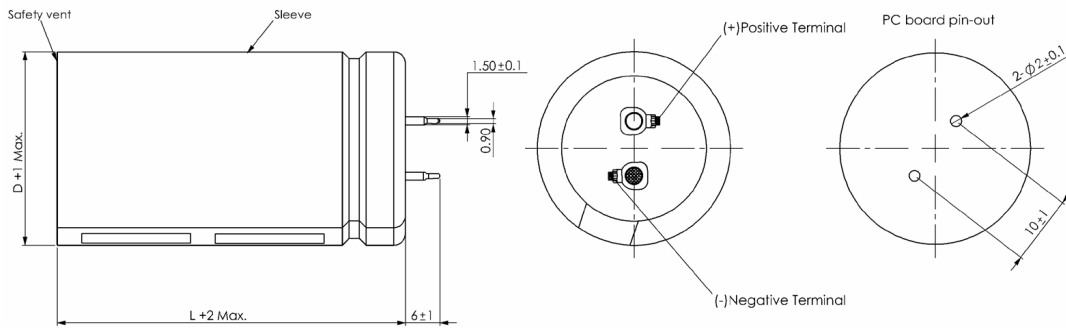

Part Description	Dimensions (mm)				Package Quantity
	L	D	d	F	
BCAP0150 P270 T07	50	25	-	-	400

Product dimensions are for reference only unless otherwise identified. Product dimensions and specifications may change without notice. Please contact Maxwell Technologies directly for any technical specifications critical to application. Products and related processes may be covered by one or more U.S. or international patents and pending applications. Please see [www.maxwell.com/patents](http://www.maxwell.com/patents) for more information.

**Maxwell Technologies, Inc.**  
**Global Headquarters**  
 3888 Calle Fortunada  
 San Diego, CA 92123  
 USA  
 Tel: +1 (858) 503-3300  
 Fax: +1 (858) 503-3301

**Maxwell Technologies SA**  
 Route de Montena 65  
 CH-1728 Rossens  
 Switzerland  
 Tel: +41 (0)26 411 85 00  
 Fax: +41 (0)26 411 85 05

**Maxwell Technologies, GmbH**  
 Leopoldstrasse 244  
 80807 Munich  
 Germany  
 Tel: +49 (0)89 4161403 0  
 Fax: +49 (0)89 4161403 99

**Maxwell Technologies Shanghai Trading Co. Ltd.**  
 Room 1005, 1006, and 1007  
 No. 1898, Gonghexin Road,  
 Jin An District, Shanghai  
 2000072, P.R. China  
 Tel: +86 21 3852 4000  
 Fax: +82 21 3852 4099

**Nesscap Co., Ltd.**  
 17, Dongtangiheung-ro  
 681 Beon-gil, Giheung-gu,  
 Yongin-si, Gyeonggi-do  
 17102  
 Republic of Korea  
 Tel: +82 31 289 0721  
 Fax: +82 31 286 6767

MAXWELL TECHNOLOGIES, MAXWELL, MAXWELL CERTIFIED INTEGRATOR, ENABLING ENERGY'S FUTURE, DURABLU, NESSCAP, XP, BOOSTCAP, D CELL, CONDIS and their respective designs and/or logos are either trademarks or registered trademarks of Maxwell Technologies, Inc., and/or its affiliates, and may not be copied, imitated or used, in whole or in part, without the prior written permission Maxwell Technologies, Inc. All contents copyright © 2018 Maxwell Technologies, Inc. All rights reserved. No portion of these materials may be reproduced in any form, or by any means, without prior written permission from Maxwell Technologies, Inc.

Компания «Life Electronics» занимается поставками электронных компонентов импортного и отечественного производства от производителей и со складов крупных дистрибьюторов Европы, Америки и Азии.

С конца 2013 года компания активно расширяет линейку поставок компонентов по направлению коаксиальный кабель, кварцевые генераторы и конденсаторы (керамические, пленочные, электролитические), за счёт заключения дистрибьюторских договоров

Мы предлагаем:

- Конкурентоспособные цены и скидки постоянным клиентам.
- Специальные условия для постоянных клиентов.
- Подбор аналогов.
- Поставку компонентов в любых объемах, удовлетворяющих вашим потребностям.
- Приемлемые сроки поставки, возможна ускоренная поставка.
- Доставку товара в любую точку России и стран СНГ.
- Комплексную поставку.
- Работу по проектам и поставку образцов.
- Формирование склада под заказчика.
- Сертификаты соответствия на поставляемую продукцию (по желанию клиента).
- Тестирование поставляемой продукции.
- Поставку компонентов, требующих военную и космическую приемку.
- Входной контроль качества.
- Наличие сертификата ISO.

В составе нашей компании организован Конструкторский отдел, призванный помогать разработчикам, и инженерам.

Конструкторский отдел помогает осуществить:

- Регистрацию проекта у производителя компонентов.
- Техническую поддержку проекта.
- Защиту от снятия компонента с производства.
- Оценку стоимости проекта по компонентам.
- Изготовление тестовой платы монтаж и пусконаладочные работы.



Тел: +7 (812) 336 43 04 (многоканальный)

Email: [org@lifeelectronics.ru](mailto:org@lifeelectronics.ru)