

Features

December 2005

- Combined T1/E1/J1 framer and LIU, with PLL and 3 HDLCs
- In T1/J1 mode the LIU can recover signals attenuated by up to 36 dB (at 772 kHz)
- In E1 mode the LIU can recover signals attenuated by up to 40 dB (at 1.024 MHz)
- Low jitter digital PLL (intrinsic jitter < 0.02UI)
- HDLCs can be assigned to any timeslot
- Comprehensive alarm detection, performance monitoring and error insertion functions
- 2.048 Mbit/s or 8.192 Mbit/s ST-BUS streams
- Support for Inverse Mux for ATM (IMA)
- Support for V5.1 and V5.2 Access Networks
- 3.3 V operation with 5 V tolerant inputs
- Intel or Motorola non-multiplexed 8-bit microprocessor port
- JTAG boundary scan

Ordering Information

MT9076BP	68 Pin PLCC	Tubes
MT9076BB	80 Pin LQFP	Trays
MT9076BPR	68 Pin PLCC	Tape & Reel
MT9076BB1	80 Pin LQFP*	Trays
MT9076BP1	68 Pin PLCC*	Tubes

*Pb Free Matte Tin

-40°C to +85°C

Applications

- T1/E1/J1 add/drop multiplexers
- Access networks
- Wireless base stations
- CO and CPE equipment interfaces
- Primary rate ISDN nodes
- Digital Cross-connect Systems (DCS)

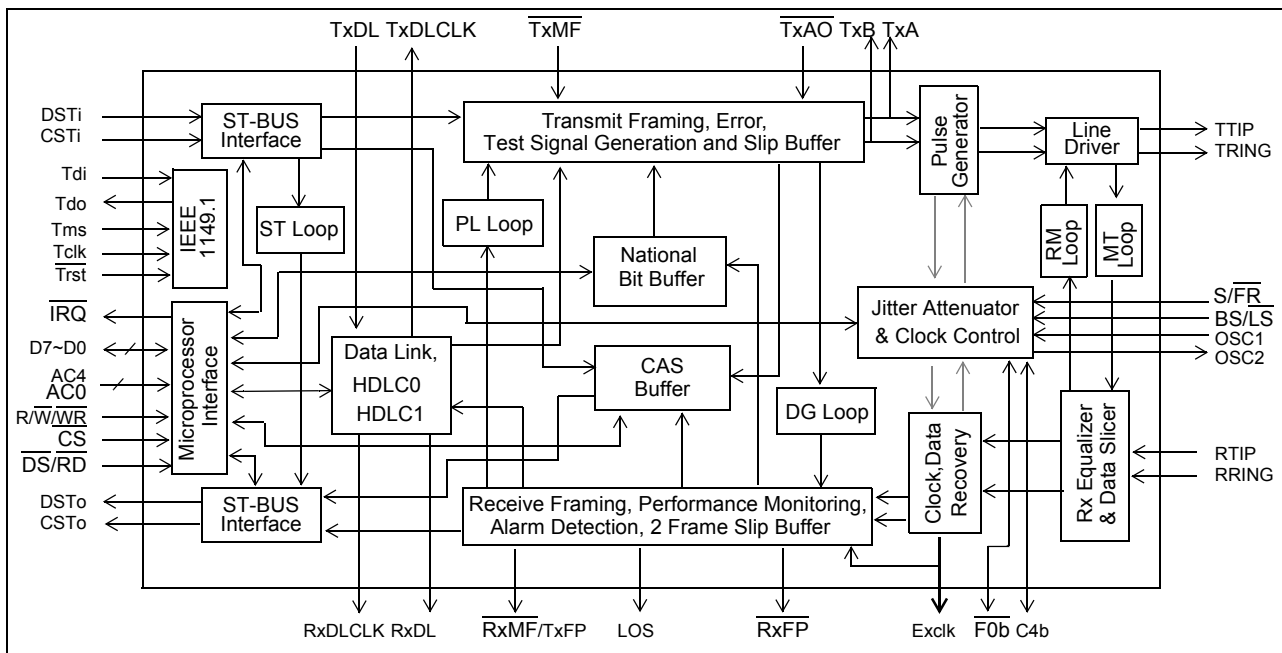
Figure 1 - MT9076 Functional Block

Description

The MT9076 is a highly featured single chip solution for terminating T1/E1/J1 trunks. It contains a long-haul LIU, an advanced framer, a high performance PLL and 3 HDLCs.

In T1 mode, the MT9076 supports D4, ESF and SLC-96 formats meeting the latest recommendations including AT&T PUB43801, TR-62411; ANSI T1.102, T1.403 and T1.408; Telcordia GR-303-CORE.

In E1 mode, the MT9076 supports the latest ITU-T Recommendations including G.703, G.704, G.706, G.732, G.775, G.796, G.823, G.964 (V5.1), G.965 (V5.2) and I.431. It also supports ETSI ETS 300 011, ETS 300 166, ETS 300 233, ETS 300 324 (V5.1) and ETS 300 347 (V5.2).

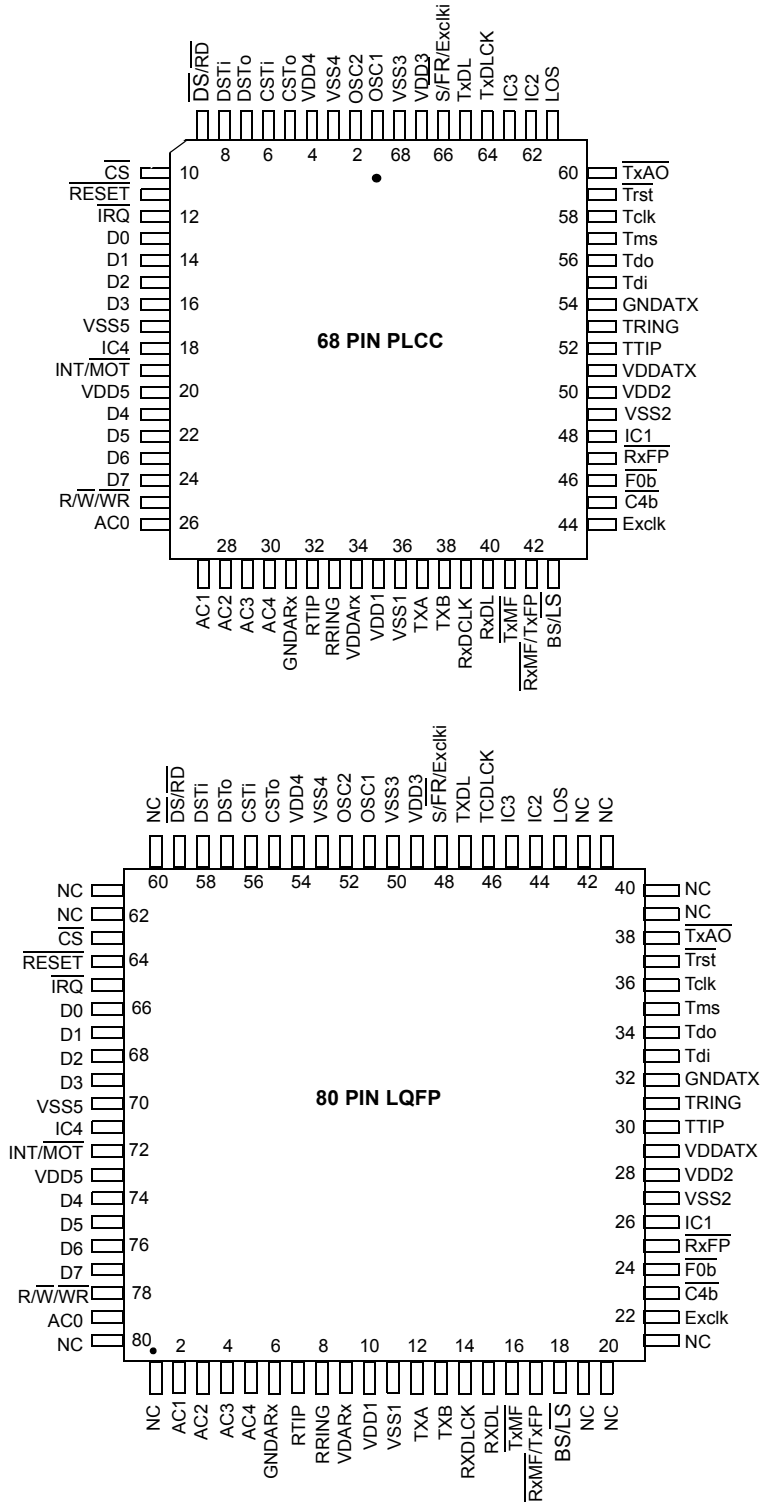

Figure 2 - Pin Connections

Pin Description

Pin #		Name	Description
PLCC	LQFP		
1	51	OSC1	Oscillator (3 V Input). This pin is either connected via a 20.000 MHz crystal to OSC2 where a crystal is used, or is directly driven when a 20.000 MHz. oscillator is employed.
2	52	OSC2	Oscillator (3 V Output). Connect a 20.0 MHz crystal between OSC1 and OSC2. Not suitable for driving other devices.
3	53	V _{SS4}	Negative Power Supply. Digital ground.
4	54	V _{DD4}	Positive Power Supply. Digital supply (+3.3 V ± 5%).
5	55	CSTo	Control ST-BUS (5 V tolerant Output). CSTo carries serial streams for CAS and CCS respectively a 2.048 Mbit/s ST-BUS status stream which contains the 30 receive signaling nibbles (ABCDZZZZ or ZZZZABCD). The most significant nibbles of each ST-BUS time slot are valid and the least significant nibbles of each ST-BUS time slot are tristated when control bit MSN (page 01H, address 1AH, bit 1) is set to 1. If MSN=0, the position of the valid and tristated nibbles are reversed.
6	56	CSTi	Control ST-BUS (5 V tolerant Input). CSTi carries serial streams for CAS and CCS respectively a 2.048 Mbit/s ST-BUS control stream which contains the 30 transmit signaling nibbles (ABCDXXXX or XXXXABCD) when RPSIG=0. When RPSIG=1 this pin has no function. The most significant nibbles of each ST-BUS time slot are valid and the least significant nibbles of each ST-BUS time slot are ignored when control bit MSN (page 01H, address 1AH, bit 1) is set to 1. If MSN=0, the position of the valid and ignored nibbles is reversed.
7	57	DSTo	Data ST-BUS (5 V tolerant Output). A 2.048 Mbit/s serial stream which contains the 24/30 PCM(T1/E1) or data channels received on the PCM 24/30 (T1/E1) line.
8	58	DSTi	Data ST-BUS (5 V tolerant Input). A 2.048 Mbit/s serial stream which contains the 24/30 (T1/E1) PCM or data channels to be transmitted on the PCM 24/30 (T1/E1) line.
9	59	$\overline{DS/RD}$	Data/Read Strobe (5 V tolerant Input). In Motorola mode (\overline{DS}), this input is the active low data strobe of the processor interface. In Intel mode (\overline{RD}), this input is the active low read strobe of the processor interface.
10	63	\overline{CS}	Chip Select (5 V tolerant Input). This active low input enables the non-multiplexed parallel microprocessor interface of the MT9076. When \overline{CS} is set to high, the microprocessor interface is idle and all bus I/O pins will be in a high impedance state.
11	64	\overline{RESET}	RESET (5 V tolerant Input). This active low input puts the MT9076 in a reset condition. RESET should be set to high for normal operation. The MT9076 should be reset after power-up. The RESET pin must be held low for a minimum of 1 μ sec. to reset the device properly.
12	65	\overline{IRQ}	Interrupt Request (5 V tolerant Output). A low on this output pin indicates that an interrupt request is presented. \overline{IRQ} is an open drain output that should be connected to V _{DD} through a pull-up resistor. An active low \overline{CS} signal is not required for this pin to function.
13 - 16	66-69	D0 - D3	Data 0 to Data 3 (5 V tolerant Three-state I/O). These signals combined with D4-D7 form the bidirectional data bus of the parallel processor interface (D0 is the least significant bit).

Pin Description (continued)

Pin #		Name	Description
PLCC	LQFP		
17	70	VSS5	Negative Power Supply. Digital ground.
18	71	IC4	Internal Connection (3 V Input). Tie to V _{SS} (Ground) for normal operation.
19	72	INT/MOT	Intel/Motorola Mode Selection (5 V tolerant Input). A high on this pin configures the processor interface for the Intel parallel non-multiplexed bus type. A low configures the processor interface for the Motorola parallel non-multiplexed type.
20	73	VDD5	Positive Power Supply. Digital supply (+3.3 V ± 5%).
21 - 24	74-77	D4 - D7	Data 4 to Data 7 (5 V tolerant Three-state I/O). These signals combined with D0-D3 form the bidirectional data bus of the parallel processor interface (D7 is the most significant bit).
25	78	R/W/WR	Read/Write/Write Strobe (5 V tolerant Input). In Motorola mode (R/W), this input controls the direction of the data bus D[0:7] during a microprocessor access. When R/W is high, the parallel processor is reading data from the MT9076. When low, the parallel processor is writing data to the MT9076. For Intel mode (WR), this active low write strobe configures the data bus lines as output.
26 - 30	79, 2-5	AC0 - AC4	Address/Control 0 to 4 (5 V tolerant Inputs). Address and control inputs for the non-multiplexed parallel processor interface. AC0 is the least significant input.
31	6	GNDARx	Receive Analog Ground. Analog ground for the LIU receiver.
32 33	7 8	RTIP RRING	Receive TIP and RING (3 V Input). Differential inputs for the receive line signal - must be transformer coupled (See Figure 5 on page 24). In digital framer mode these pins accept digital 3 volt signals from a physical layer device. They may accept a split phase unipolar signal (RTIP and RRING employed) or an NRZ signal (RTIP only used).
34	9	VDDARx	Receive Analog Power Supply. Analog supply for the LIU receiver (+3.3 V ± 5%).
35	10	VDD1	Positive Power Supply. Digital supply (+3.3 V ± 5%).
36	11	VSS1	Negative Power Supply. Digital ground.
37	12	TxA	Transmit A (5 V tolerant Output). When the internal LIU is disabled (digital framer only mode), if control bit NRZ=1, an NRZ output data is clocked out on pin TxA with the rising edge of Exclk (TxB has no function when NRZ format is selected). If NRZ=0, pins TxA and TxB are a complementary pair of signals that output digital dual-rail data clocked out with the rising edge of Exclk.
38	13	TxB	Transmit B (5 V tolerant Output). When the internal LIU is disabled and control bit NRZ=0, pins TxA and TxB are a complementary pair of signals that output digital dual-rail data clocked out with the rising edge of Exclk.
39	14	RxDLCLK	Data Link Clock (5 V tolerant Output). A gapped clock signal derived from the extracted line clock, available for an external device to clock in RxDL data (at 4, 8, 12, 16 or 20 kHz) on the rising edge.
40	15	RxDL	Receive Data Link (5 V tolerant Output). A serial bit stream containing received line data after zero code suppression. This data is clocked out with the rising edge of Exclk.
41	16	TxMF	Transmit Multiframe Boundary (5 V tolerant Input). An active low input used to set the transmit multiframe boundary (CAS or CRC multiframe). The MT9076 will generate its own multiframe if this pin is held high. This input is usually pulled high for most applications.

Pin Description (continued)

Pin #		Name	Description
PLCC	LQFP		
42	17	$\overline{\text{RxMF/TxFP}}$	Receive Multiframe Boundary / Transmit Frame Boundary (5 V tolerant Output). If the control bit Tx8KEN (page 02H address 10H bit 2) is low, this negative output pulse delimits the received multiframe boundary. The next frame output on the data stream (DSTo) is basic frame zero on the T1 or PCM 30 link. In E1 mode this receive multiframe signal can be related to either the receive CRC multiframe (page 01H, address 17H, bit 6, MFSEL=1) or the receive signaling multiframe (MFSEL=0). If the control bit Tx8KEN is set high, this positive output pulse delimits the frame boundary (the first bit transmit in the frame) for the digital output stream on pins TXA and TXB.
43	18	$\text{BS}/\overline{\text{LS}}$	Bus/Line Synchronization Mode Selection (5 V tolerant Input). If high, $\overline{\text{C4b}}$ and $\overline{\text{F0b}}$ will be inputs; if low, C4b and F0b will be outputs.
44	22	Exclk	2.048 MHz in E1 mode or 1.544 MHz in T1 mode, Extracted Clock (5 V tolerant Output). The clock extracted from the received signal and used internally to clock in data received on RTIP and RRING.
45	23	$\overline{\text{C4b}}$	4.096 MHz System Clock (5 V tolerant Input/Output). $\overline{\text{C4b}}$ is the clock for the ST-BUS sections and transmit serial PCM data of the MT9076. In the free-run ($\text{S}/\overline{\text{FR}}/\text{Exclki}=0$) or line synchronous mode ($\text{S}/\overline{\text{FR}}/\text{Exclki}=1$ and $\text{BS}/\overline{\text{LS}}=0$) this signal is an output, while in bus synchronous mode ($\text{S}/\overline{\text{FR}}/\text{Exclki}=1$ and $\text{BS}/\text{LS}=1$) this signal is an input clock.
46	24	$\overline{\text{F0b}}$	Frame Pulse (5 V tolerant Input/Output). This is the ST-BUS frame synchronization signal, which delimits the 32 channel frame of CSTi, CSTo, DSTi, DSTo and the PCM30 link. In the free-run ($\text{S}/\overline{\text{FR}}/\text{Exclki}=0$) or line synchronous mode ($\text{S}/\overline{\text{FR}}/\text{Exclki}=1$ and $\text{BS}/\overline{\text{LS}}=0$) this signal is an output, while in bus synchronous mode ($\text{S}/\overline{\text{FR}}/\text{Exclki}=1$ and $\text{BS}/\text{LS}=1$) this signal is an input.
47	25	$\overline{\text{RxFP}}$	Receive Frame Pulse/Receive CCS Clock (5 V tolerant Output). An 8kHz pulse signal, which is low for one extracted clock period. This signal is synchronized to the receive DS1 or PCM 30 basic frame boundary.
48	26	IC1	Internal Connection. Must be left open for normal operation.
49	27	$\text{V}_{\text{SS}2}$	Negative Power Supply. Digital ground.
50	28	$\text{V}_{\text{DD}2}$	Positive Power Supply. Digital supply (+3.3 V \pm 5%).
51	29	VDD_{ATx}	Transmit Analog Power Supply. Analog supply for the LIU transmitter (+3.3 V \pm 5%).
52 53	30 31	TTIP TRING	Transmit TIP and RING(Output). Differential outputs for the transmit line signal - must be transformer coupled (See Figure 5 on page 24).
54	32	GND_{ATx}	Transmit Analog Ground. Analog ground for the LIU transmitter.
55	33	Tdi	IEEE 1149.1a Test Data Input (3 V Input). If not used, this pin should be pulled high.
56	34	Tdo	IEEE 1149.1a Test Data Output (5 V tolerant Output). If not used, this pin should be left unconnected.
57	35	Tms	IEEE 1149.1a Test Mode Selection (3 V Input). If not used, this pin should be pulled high.
58	36	Tclk	IEEE 1149.1a Test Clock Signal (3 V Input). If not used, this pin should be pulled high.
59	37	$\overline{\text{Trst}}$	IEEE 1149.1a Reset Signal (3 V Input). If not used, this pin should be held low.

Pin Description (continued)

Pin #		Name	Description
PLCC	LQFP		
60	38	$\overline{\text{TxAO}}$	Transmit All Ones (Input). High - TTIP, TRING will transmit data normally. Low - TTIP, TRING will transmit an all ones signal.
61	43	LOS	Loss of Signal or Synchronization (5 V tolerant Output). When high, and LOS/LOF (page 0, this signal indicates that the receive portion of the MT9076 is either not detecting an incoming signal (bit LLOS on page 03H address 16H is one) or is detecting a loss of basic frame alignment condition (bit TSYNC (T1), SYNC (E1) on page 03H address 10H is one). If LOS/LOF=1, a high on this pin indicates a loss of signal condition.
62	44	IC2	Internal Connection (3 V Input). Tie to V_{SS} (Ground) for normal operation.
63	45	IC3	Internal Connection (3 V Input). Tie to V_{SS} (Ground) for normal operation.
64	46	TxDLCLK	Transmit Data Link Clock (5 V tolerant Output). A gapped clock signal derived from a gated 2.048 Mbit/s clock for transmit data link at 4, 8, 12, 16 or 20 kHz. The transmit data link data (TxDL) is clocked in on the rising edge of TxDLCLK. TxDLCLK can also be used to clock DL data out of an external serial controller.
65	47	TxDL	Transmit Data Link (5 V tolerant Input). An input serial stream of transmit data link data at 4, 8, 12, 16 or 20 kbit/s.
66	48	$\overline{\text{S/FR/Exclki}}$	Synchronization/ Freerun / Extracted Clock (5 V tolerant Input). If low, and the internal LIU is enabled, the MT9076 is in free run mode. Pins 45 C4b and 46 F0b are outputs generating system clocks. Slips will occur in the receive slip buffer as a result of any deviation between the MT9076's internal PLL (which is free - running) and the frequency of the incoming line data. If high, and the internal LIU is enabled, the MT9076 is in Bus or Line Synchronization mode depending on the BS/LS pin. If the internal LIU is disabled, in digital framer mode, this pin (Exclki) takes an input clock 1.544 MHz (T1)/ 2.048 MHz (E1) that clocks in the received digital data on pins RXA and RXB with its rising edge.
67	49	VDD3	Positive Power Supply. Digital supply (+3.3 V \pm 5%).
68	50	VSS3	Negative Power Supply. Digital ground.

Device Overview

The MT9076 is a T1/E1/J1 single chip transceiver that incorporates an advanced framer, a long-haul LIU (Line Interface Unit), a low jitter PLL (Phase Locked Loop) and 3 HDLCs (High-level Data Link Controller). The T1, E1 and J1 operating modes are selectable under software control.

Standards Compliance

In T1 mode, the MT9076 meets or supports the latest recommendations including Telcordia GR-303-CORE, AT&T PUB43801, TR-62411, ANSI T1.102, T1.403 and T1.408. In T1 ESF mode the CRC-6 calculation and yellow alarm can be configured to meet the requirements of a J1 interface.

In E1 mode, the MT9076 meets or supports the latest ITU-T Recommendations for PCM 30 and ISDN primary rate including G.703, G.704, G.706, G.732, G.775, G.796, G.823, G.964 (V5.1), G.965 (V5.2) and I.431. It also meets or supports ETSI ETS 300 011, ETS 300 166, ETS 300 233, ETS 300 324 (V5.1) and ETS 300 347 (V5.2).

Microprocessor Port

The MT9076 registers are accessible via an 8-bit parallel Motorola or Intel non-multiplexed microprocessor interface.

LIU

The MT9076 LIU interfaces the digital framer functions to either the DS1 (T1 mode) or PCM 30 (E1 mode) transformer-isolated four wire line.

In T1 mode, the LIU can pre-equalize the transmit signal to meet the T1.403 and T1.102 pulse templates after attenuation by 0 - 655 feet of 22 AWG PIC cable, alternatively it can provide line build outs of 7.5 dB, 15 dB and 22.5 dB. In T1 mode the receiver can recover signals attenuated by up to 36 dB at 772 kHz.

In E1 mode, the LIU transmits signals that meet the G.703 2.048 Mbit/s pulse template and the receiver can recover signals attenuated by up to 40 dB at 1024 kHz.

Digital Framer Only Mode

To accommodate some special applications, the MT9076 supports a digital framer only mode that provides direct access to the transmit and receive data in digital format, i.e., by-passing the analog LIU front-end. In digital framer only mode, the MT9076 supports unipolar non-return to zero or bipolar return to zero data.

PLL and Slip Buffers

The MT9076 PLL attenuates jitter from 2.5 Hz with a roll-off of 20 dB/decade. The intrinsic jitter is less than 0.02 UI. The device can operate in one of three timing modes: System Bus Synchronous Mode, Line Synchronous Mode, or Free-run Mode. In all three timing modes the low jitter output of the PLL provides timing to the transmit side of the LIU.

In T1 mode, the receive and transmit paths both include two-frame slip buffers. The transmit slip buffer features programmable delay and serves as a Jitter Attenuator (JA) FIFO and a rate converter between the ST-BUS and the 1.544 Mbit/s T1 line rate.

In E1 mode, the receive path includes a two-frame slip buffer and the transmit path contains a 128 bit Jitter Attenuator (JA) FIFO with programmable depth.

Interface to the System Backplane

On the system side the MT9076 framers can interface to a 2.048 Mbit/s or 8.192 Mbit/s ST-BUS backplane.

There is an asynchronous mode for Inverse MUX for ATM (IMA) applications, this enables the framer to interface to a 1.544 Mbit/s (T1) or 2.048 Mbit/s (E1) serial bus with asynchronous transmit and receive timing.

Framing Modes

The MT9076 framers operate in termination mode or transparent mode. In the receive transparent mode, the received line data is channelled to the DSTo pin with arbitrary frame alignment. In the transmit transparent mode, no framing or signaling is imposed on the data transmitted from the DSTi pin onto the line.

In T1 mode, the framers operate in any of the following framing modes: D4, Extended Superframe (ESF) or SLC-96.

In E1 mode, the framers run three framing algorithms: basic frame alignment, signaling multiframe alignment and CRC-4 multiframe alignment. The Remote Alarm Indication (RAI) bit is automatically controlled by an internal state machine.

Access to the Maintenance Channel

The T1 ESF Facility Data Link (FDL) bits can be accessed in the following three ways: Through the data link pins TxDL, RxDL, RxDLC and TxDLC; through internal registers for Bit Oriented Messages; through an embedded HDLC.

In E1 mode, the Sa bits (bits 4-8 of the non-frame alignment signal) can be accessed in four ways: Through data link pins TxDL, RxDL, RxDLC and TxDLC, through single byte transmit and receive registers; through five byte transmit and receive national bit buffers; through an embedded HDLC.

Robbed Bit Signaling/Channel Associated Signaling

Robbed bit signaling and channel associated signaling information can be accessed two ways: Via the microport; via the CSTi and CSTo pins. Signaling information is frozen upon loss of multiframe alignment.

In T1 mode, the MT9076 supports AB and ABCD robbed bit signaling. Robbed bit signaling can be enabled on a channel by channel basis.

In E1 mode the MT9076 supports Channel Associated Signaling (CAS) multiframing.

HDLCs

The MT9076 provides three embedded HDLCs with 128 byte deep transmit and receive FIFOs.

In T1 mode, the embedded HDLCs can be assigned to any channel and can operate at 56 kbit/s or 64 kbit/s. In T1 ESF mode, HDLCO can be assigned to the 4 kbit/s FDL.

In E1 mode, the embedded HDLCs can be assigned to any timeslot and can operate at 64 kbit/s. HDLCO can be assigned to timeslot 0 Sa bits (bits 4-8 of the non-frame alignment signal) and can operate at 4,8,12,16 or 20 kbit/s.

Performance Monitoring and Debugging

The MT9076 has a comprehensive suite of performance monitoring and debugging features. These include error counters, loopbacks, deliberate error insertion and a $2^{15} - 1$ QRS/PRBS generator/detector.

Interrupts

The MT9076 provides a comprehensive set of maskable interrupts. Interrupt sources consist of synchronization status, alarm status, counter indication and overflow, timer status, slip indication, maintenance functions and receive signaling bit changes.

MT9076 Detailed Feature List

Standards Compliance and Support

T1/J1 Mode

ANSI:

T1.102, T1.231, T1.403, T1.408

AT&T:

TR 62411, PUB43801

Telcordia:

GR-303-CORE

TTC:

JT-G703, JT-G704, JT-G706

E1 Mode

ETSI:

ETS 300 011, ETS 300 166, ETS 300 233,
ETS 300 324, ETS 300 347

ITU:

G.703, G.704, G.706, G.732 G.775,
G.796, G.823, I.431, G.964, G.965

Line Interface Unit (LIU)

- T1 and E1 modes use the same 1:1 transmit and receive transformers
- Internal register allows termination impedance to be changed under software control.
- Programmable pulse shapes and pulse amplitudes
- Automatic or manual receiver equalization
- Receive signal peak amplitude is reported with 8-bit resolution
- Output pin to indicate Loss Of Signal/ Loss Of Frame synchronization
- LIU output is disabled at power-up until enabled by software
- Input pin to force transmission of AIS

T1/J1 Mode

- Reliably recovers signals with cable attenuation up to 36 dB @ 772 kHz
- Transmit pulse meets T1.403 and T1.102 pulse templates
- Indicates analog Loss Of Signal if the received signal is more than 20 dB or 40 dB below nominal for more than 1 ms
- Receiver tolerates jitter as required by AT&T TR62411

E1 Mode

- Reliably recovers signals with cable attenuation up to 40 dB @ 1024 kHz
- Transmit pulse meets G.703 pulse template
- Indicates analog Loss Of Signal if the received signal is more than 20 dB or 40 dB below nominal for more than 1 ms
- Receiver tolerates jitter as required by ETSI ETS 300 011

T1/J1 ModeE1 Mode

- Transmit Pre-equalization and Line Build Out options:

0-133 feet
 133-266 feet
 266-399 feet
 399-533 feet
 533-655 feet
 -7.5 dB
 -15 dB
 -22.5 dB

Digital Framing Mode

- The LIU can be disabled and bypassed to allow the MT9076 to be used as a digital framer
- Single phase NRZ or two phase NRZ modes are software selectable
- Line coding is software selectable

Phase Lock Loop

- Locks to a 4.096 MHz input clock, or to the 1.544 MHz / 2.048 MHz extracted clock
- IMA mode locks to 1,544 MHz or 2,048 MHz external clock
- Attenuates jitter from less than 2.5 Hz with a roll off of 20 dB/decade
- Attenuates jitter in the transmit or receive direction
- Intrinsic jitter less than 0.02 UI
- Meets the jitter characteristics as specified in AT&T TR62411
- Meets the jitter characteristics as specified in ETS 300 011
- Can be operated in Free-run, Line Synchronous or System Bus Synchronous modes

Access and Control

- MT9076 registers can be accessed via an 8-bit non-multiplexed parallel microprocessor port
- The parallel port can be configured for Motorola or Intel style control signals

Backplane Interfaces

- 2.048 Mbit/s or 8.192 Mbit/s ST-BUS
- IMA mode, 1.544 Mbit/s (T1) or 2.048 Mbit/s (E1) serial bus with asynchronous transmit and receive timing for Inverse MUX for ATM (IMA) applications. Slip buffers are bypassed and signaling is disabled.
- CSto/CSTi pins can be used to access the receive/transmit signaling data
- RxDL pin can be used to access the entire B8ZS/HDB3 decoded receive stream including framing bits
- TxDL pin can be used to transmit data on the FDL (T1) or the Sa bits (E1)

T1/J1 ModeE1 Mode

- PCM-24 channels 1-24 are mapped to ST-BUS channels 0-23 respectively
- The framing-bit is mapped to ST-BUS channel 31
- PCM-30 timeslots 0-31 are mapped to ST-BUS channels 0-31 respectively

Data LinkT1/J1 Mode

- Three methods are provided to access the datalink:
 1. TxDL and RxDL pins support transmit and receive datalinks
 2. Bit Oriented Messages are supported via internal registers
 3. An internal HDLC can be assigned to transmit/receive over the FDL in ESF mode

E1 Mode

- Two methods are provided to access the datalink:
 1. TxDL and RxDL pins support transmit and receive datalinks over the Sa4~Sa8 bits
 2. An internal HDLC can be assigned to transmit/receive data via the Sa4~Sa8 bits
- In transparent mode, if the Sa4 bit is used for an intermediate datalink, the CRC-4 remainder can be updated to reflect changes to the Sa4 bit

Access and Monitoring for National (Sa) Bits (E1 mode only)

- In addition to the datalink functions, the Sa bits can be accessed using:
 - Single byte register
 - Five byte transmit and receive national bit buffers
 - A maskable interrupt is generated on the change of state of any Sa bit

Three Embedded Floating HDLCs (HDLC0, HDLC1, HDLC2)

- Successive writes/reads can be made to the transmit/receive FIFOs at 160 ns or 80 ns intervals
- Flag generation and Frame Check Sequence (FCS) generation and detection, zero insertion and deletion
- Continuous flags, or continuous 1s are transmitted between frames
- Transmit frame-abort
- Transmit end-of-packet after a programmable number of bytes (up to 65,536 bytes)
- Invalid frame handling:
 - Frames yielding an incorrect FCS are tagged as bad packets
 - Frames with fewer than 25 bits are ignored
 - Frames with fewer than 32 bits between flags are tagged as bad packets
 - Frames interrupted by a Frame-Abort sequence remain in the FIFO and an interrupt is generated
 - Access is provided to the receive FCS
- FCS generation can be inhibited for terminal adaptation
- Recognizes single byte, dual byte and all call addresses
- Independent, 16-128 byte deep transmit and receive FIFOs
- Receive FIFO maskable interrupts for near full (programmable levels) and overflow conditions
- Transmit FIFO maskable interrupts for nearly empty (programmable levels) and underflow conditions
- Maskable interrupts for transmit end-of-packet and receive end-of-packet
- Maskable interrupts for receive bad-frame (includes frame abort)
- Transmit-to-receive and receive-to-transmit loopbacks are provided
- Transmit and receive bit rates and enables are independent

- Frame aborts can be sent under software control and they are automatically transmitted in the event of a transmit FIFO underrun

T1/J1 Mode*HDLC0*

- Assignable to the ESF Facility Data Link or any channel
- Operates at 4 kbps, 56 kbps or 64 kbps

HDLC1, HDLC2

- Assignable to any channel
- Operates at 56 kbps or 64 kbps

E1 Mode*HDLC0*

- Assigned to timeslot-0, bits Sa4~Sa8 or any other timeslot
- Operates at 4, 8, 12, 16 or 20 kbps depending on which Sa bits are selected for HDLC0 use

HDLC1, HDLC2

- Assigned to any timeslot except timeslot-0
- Operates at 64 kbps

Slip BuffersT1/J1 Mode*Transmit Slip Buffer*

- Two-frame slip buffer capable of performing a controlled slip
- Intended for rate conversion and jitter attenuation in the transmit direction
- Programmable delay
- Transmit slips are independent of receive slips
- Indication of slip direction

Receive Slip Buffer

- Two-frame slip buffer capable of performing a controlled slip
- Wander tolerance of 142 UI (92 μ s) peak
- Indication of slip direction

E1 Mode*Receive Slip Buffer*

- Two-frame slip buffer capable of performing a controlled slip
- Wander tolerance of 208 UI peak-to-peak
- Indication of slip direction

Jitter Attenuator FIFO

- A jitter attenuator FIFO is available on the transmit side in E1 mode and in IMA mode. The depth of the JA FIFO can be configured to be from 16 bits deep to 128 bits deep in 16 bit increments

Inverse Mux for ATM (IMA) ModeT1/J1 Mode

- Transmit and receive datastreams are independently timed
- The transmit clock synchronizes to a 1.544 MHz clock

E1 Mode

- Transmit and receive datastreams are independently timed
- Receive slip buffer is bypassed
- CAS and HDLCs are disabled

T1/J1 Mode

- Transmit and receive slip buffers are bypassed
- Robbed bit signaling and HDLCs are disabled

E1 Mode**Framing Algorithm**T1/J1 Mode

- Synchronizes with D4 or ESF protocols
- Supports SLC-96 framing
- Framing circuit is off-line
- Transparent transmit and receive modes
- In D4 mode the Fs bits can optionally be cross checked with the Ft bits
- The start of the ESF multiframe can be determined by the following methods:
 - Free-run
 - Software reset
 - Synchronized to the incoming multiframe
- An automatic reframe is initiated if the framing bit error density exceeds the programmed threshold
- In transparent mode, no reframing is forced by the device
- Software can force a reframe at any time
- In ESF mode the CRC-6 bits can be optionally confirmed before forcing a new frame alignment
- During a reframe the signaling bits are frozen and error counting for Ft, Fs, ESF framing pattern and CRC-6 bits is suspended
- If J1 CRC-6 is selected the Fs bits are included in the CRC-6 calculation
- J1 CRC-6 and J1 Yellow Alarm can be independently selected
- Supports robbed bit signaling

E1 Mode

- MT9076 contains 3 distinct and independent framing algorithms
 1. Basic frame alignment
 2. Signaling multiframe alignment
 3. CRC-4 multiframe alignment
- Transparent transmit and receive modes
- Automatic interworking between interfaces with and without CRC-4 processing capabilities is supported
- An automatic reframe is forced if 3 consecutive frame alignment patterns or three consecutive non-frame alignment bits are received in error
- In transparent mode, no reframing is forced by the device
- Software can force a reframe at any time
- Software can force a multiframe reframe at any time
- E-bits can optionally be set to zero until CRC synchronization is achieved
- Optional automatic RAI
- Supports CAS multiframing
- Optional automatic Y-bit to indicate CAS multiframe alignment

Line CodingT1/J1 Mode

- B8ZS or AMI line coding
- Pulse density enforcement
- Forced ones insertion

E1 Mode

- HDB3 or AMI line coding

Channel Associated Signaling

- ABCD or AB bits can be automatically inserted and extracted
- Transmit ABCD or AB bits can be passed via the microport or via the CSTi pin
- Receive ABCD or AB bits are accessible via the microport or via the CSTo pin
- Most significant or least significant CSTi/CSTo nibbles can be selected to carry signaling bits
- Unused nibble positions in the CSTi/CSTo bandwidth are tri-stated
- An interrupt is provided in the event of changes in any of the signaling bits
- Receive signaling bits are frozen if signaling multiframe alignment is lost

T1/J1 Mode

- Signaling bits can be debounced by 6 ms

E1 Mode

- Signaling bits can be debounced by 14 ms

Alarms

T1/J1 Mode

D4 Yellow Alarm, two types

1. Bit position 2 is zero for virtually every DS0 over 48ms
2. Two consecutive ones in the S-bit position of the twelfth frame

ESF Yellow Alarm, two types

1. Reception of 0000000011111111 in seven or more codewords out of ten (T1)
2. Reception of 1111111111111111 in seven or more codewords out of ten (J1)

Alarm Indication Signal (AIS)

- Declared if fewer than six zeros are detected during a 3 ms interval

Loss Of Signal (LOS)

- Analog Loss Of Signal is declared if the received signal is more than 20 dB or 40 dB below nominal for at least 1 ms
- Digital Loss Of Signal is declared if 192 or 32 consecutive zeros are received
- Output pin indicates LOS and/or loss of frame alignment

E1 Mode

Remote Alarm Indication (RAI)

- Bit 3 of the receive NFAS

Alarm Indication Signal (AIS)

- Unframed all ones signal for at least a double frame or two double frames

Timeslot 16 Alarm Indication Signal

- All ones signal in timeslot 16

Loss Of Signal (LOS)

- Analog Loss Of Signal is declared if the received signal is more than 20 dB or 40 dB below nominal for at least 1 ms
- Digital Loss Of Signal is declared if 192 or 32 consecutive zeros are received
- Output pin indicates LOS and/or loss of frame alignment

Remote Signaling Multiframe Alarm

- Y-bit of the multiframe alignment signal

Maskable InterruptsT1/J1 Mode

- Change of state of terminal synchronization
- Change of state of multiframe synchronization
- Change of received bit oriented message
- Change of state of reception of AIS
- Change of state of reception of LOS
- Reception of a severely errored frame
- Transmit slip
- Receive slip
- Receive framing bit error
- Receive CRC-6 error
- Receive yellow alarm
- Change of receive frame alignment
- Receive line code violation
- Receive PRBS error
- Pulse density violation
- Framing bit error counter overflow
- CRC-6 error counter overflow
- Out of frame alignment counter overflow
- Change of frame alignment counter overflow
- Line code violation counter overflow
- PRBS error counter overflow
- PRBS multiframe counter overflow
- Multiframes out of alignment counter overflow
- Loop code detected
- One second timer
- Five second timer
- Receive new bit oriented message (debounced)
- Signaling (AB or ABCD) bit change

E1 Mode

- Change of state of basic frame alignment
- Change of state of multiframe synchronization
- Change of state of CRC-4 multiframe synchronization
- Change of state of reception of AIS
- Change of state of reception of LOS
- Reception of consecutively errored FASs
- Receive remote signaling multiframe alarm
- Receive slip
- Receive FAS error
- Receive CRC-4 error
- Receive E-bit
- Receive AIS in timeslot 16
- Line code violation
- Receive PRBS error
- Receive auxiliary pattern
- Receive RAI
- FAS error counter overflow
- CRC-4 error counter overflow
- Out of frame alignment counter overflow
- Receive E-bit counter overflow
- Line code violation counter overflow
- PRBS error counter overflow
- PRBS multiframe counter overflow
- Change of state of any Sa bit or Sa nibble
- Jitter attenuator within 4 bits of overflow/underflow
- One second timer
- Two second timer
- Signaling (CAS) bit change

HDLC Interrupts

- Go ahead pattern received
- End of packet received
- End of packet transmitted
- End of packet read from receive FIFO
- Transmit FIFO low
- Frame abort received
- Transmit FIFO underrun
- Receive FIFO full
- Receive FIFO overflow

Error Counters

- All counters can be preset or cleared under software control
- Maskable occurrence interrupt
- Maskable overflow interrupt
- Counters can be latched on one second intervals

T1/J1 Mode

- PRBS Error Counter (16-bit)
- CRC Multiframe Counter (16-bit)
- Framing Bit Error Counter (8-bit)
- Out of Frame Alignment Counter (4-bit)
- Change of Frame Alignment Counter (4-bit)
- Multiframes Out of Sync Counter (8-bit)
- Line Code Violation / Excessive Zeros Counter (16-bit)
- CRC-6 Error Counter (16-bit)

E1 Mode

- Errored FAS Counter (8-bit)
- E-bit Counter (10-bit)
- Line Code Violation / Excessive Zeros Counter (16-bit)
- CRC-4 Error Counter (16-bit)
- PRBS Error Counter (8-bit)
- CRC Multiframe Counter (8-bit)

Error InsertionT1/J1 Mode

- Bipolar Violations
- CRC-6 Errors
- Ft Errors
- Fs Errors
- Payload Errors
- Loss of Signal Error

E1 Mode

- Bipolar Violations
- CRC-4 Errors
- FAS Errors
- NFAS Errors
- Payload Errors
- Loss of Signal Error

Loopbacks

- Digital loopback
- Remote loopback
- ST-BUS loopback
- Payload loopback
- Metallic loopback
- Local timeslot loopback
- Remote timeslot loopback

Per Timeslot Control

The following features can be controlled on a per timeslot basis:

- Clear Channel Capability (only used in T1/J1)
- Choice of sourcing transmit signaling bits from microport or CSTi pin
- Remote timeslot loopback
- Local timeslot loopback
- PRBS insertion and reception
- Digital milliwatt pattern insertion
- Per channel inversion
- Transmit message mode

Table of Contents

1.0 MT9076 Line Interface Unit (LIU)	22
1.1 Receiver	22
1.2 Transmitter	23
1.3 20 MHz Clock	27
1.4 Phase Lock Loop (PLL)	27
2.0 Clock Jitter Attenuation Modes	28
2.1 Jitter Attenuator FIFO	29
2.2 IMA Mode	29
2.2.1 T1 Mode	29
2.2.2 E1 Mode	29
3.0 The Digital Interface	29
3.1 T1 Digital Interface	29
3.2 Frame and Superframe Structure in T1 Mode	30
3.2.1 Multiframe	30
3.3 E1 Digital Interface	32
3.3.1 Basic Frame Alignment	33
3.3.2 CRC-4 Multiframe in E1 Mode	34
3.3.3 CAS Signaling Multiframe in E1 Mode	35
4.0 MT9076 Access and Control	36
4.1 The Control Port Interface	36
4.2 Control and Status Register Access	36
4.3 Identification Code	37
4.3.1 ST-BUS Streams	37
5.0 Reset Operation (Initialization)	37
6.0 Transmit Data All Ones (TxAO) Operation	38
7.0 Data Link Operation	38
7.1 Data Link Operation in E1 Mode	38
7.2 Data Link Operation in T1 Mode	39
7.2.1 External Data Link	40
7.2.2 Bit - Oriented Messaging	40
8.0 Floating HDLC Channels	40
8.1 Channel Assignment	41
8.2 HDLC Description	41
8.2.1 HDLC Frame Structure	41
8.2.2 Data Transparency (Zero Insertion/Deletion)	42
8.2.3 Invalid Frames	42
8.2.4 Frame Abort	42
8.2.5 Interframe Time Fill and Link Channel States	42
8.2.6 Go-Ahead	42
8.3 HDLC Functional Description	43
8.3.1 HDLC Transmitter	43
8.3.2 HDLC Receiver	44
9.0 Slip Buffers	45
9.1 Slip Buffer in T1 Mode	45
9.2 Slip Buffer in E1 Mode	48
10.0 Framing Algorithm	49
10.1 Frame Alignment in T1 Mode	49
10.2 Frame Alignment in E1 Mode	50
10.2.1 Notes for Synchronization State Diagram (Figure 14)	52
10.3 Reframe	52
10.3.1 E1 Mode	52

Table of Contents

10.3.2 T1 Mode	52
11.0 MT9076 Channel Signaling	52
11.1 Channel Signaling in T1 Mode	52
11.2 Channel Signaling in E1 Mode	53
12.0 Loopbacks	54
13.0 Performance Monitoring	55
13.1 Error Counters	55
13.2 T1 Counters	55
13.2.1 Framing Bit Error Counter (FC7-0)	55
13.2.2 Out Of Frame/Change Of Frame Alignment Counter (OOF3-0/COFA3-0)	55
13.2.3 Multiframes out of Sync Counter (MFOOF7-MFOOF0)	56
13.2.4 CRC-6 Error Counter (CC15-0)	56
13.2.5 Line Code Violation Error Counter (LCV15-LCV0)	56
13.2.6 PRBS Error Counter (PS7-0)	56
13.2.7 CRC Multiframe Counter for PRBS (PSM7-0)	56
13.3 E1 Counters	57
13.4 Errored FAS Counter (EFAS7-EFAS0)	57
13.5 E-bit Counter (EC15-0)	57
13.6 Line Code Violation Error Counter (LCV15-LCV0)	57
13.7 CRC-4 Error Counter (CC15-0)	57
13.8 PRBS Error Counter (PS7-0)	57
13.9 CRC Multiframe Counter for PRBS (PSM7-0)	58
14.0 Error Insertion	58
15.0 Per Time Slot Control Words	58
15.1 Clear Channel Capability	58
15.2 Microport Signaling	58
15.3 Per Time Slot Looping	59
15.4 PRBS Testing	59
15.5 Digital Milliwatt	59
15.6 Per Channel Inversion	60
15.7 Transmit Message	60
16.0 Alarms	60
16.1 Automatic Alarms	61
17.0 Detected Events	61
17.1 T1 Mode	61
17.1.1 Severely Errored Frame Event	61
17.1.2 Loop Code Detect	61
17.1.3 Pulse Density Violation Detect	61
17.1.4 Timer Outputs	61
17.2 E1 mode	62
17.2.1 Consecutive Frame Alignment Patterns (CONFAP)	62
17.2.2 Receive Frame Alignment Signals	62
17.2.3 Receive Non Frame Alignment Signal	62
17.2.4 Receive Multiframe Alignment Signals	62
18.0 Interrupts	62
18.1 Interrupts on T1 Mode	62
18.2 Interrupts on E1 Mode	63
19.0 Digital Framer Mode	64
19.1 T1 Mode	64
19.2 E1 mode	64
20.0 Control and Status Registers	65

Table of Contents

20.1 T1 Mode	65
20.1.1 Master Control 1 (Page 01H) (T1)	65
20.1.2 Master Control 2 (Page 02H) (T1)	78
20.1.3 Master Status 1 (Page03H) (T1)	85
20.1.4 Master Status 2 (Page 04H) (T1)	90
20.1.5 Per Channel Transmit Signalling (Pages 5 and 6) (T1)	97
20.2 Per Time Slot Control Words (Pages 7 and 8) (T1)	98
20.2.1 Per Channel Receive Signaling (T1 and E1 mode) (Pages 9 and 0AH)	100
20.3 E1 Mode	101
20.3.1 Master Control 1 (Page 01H) (E1)	101
20.4 Master Control 2 (Page-2)	115
20.4.1 Master Control 2 (Page 02H) (E1)	115
20.5 Master Status 1 (Page 03H) (E1)	122
21.0 Master Status 2 (Page-4)	131
21.1 Master Status 2 (Page 04H) (E1)	131
21.2 Per Channel Transmit signaling (Pages 5 and 6) (E1)	138
21.3 Per Time Slot Control Words (Pages 7 and 8) (E1)	139
21.4 Per Channel Receive signaling (Pages 9 and 0AH) (E1)	140
22.0 HDLC Control and Status	142
23.0 Transmit National Bit Buffer (Page 0EH)	153
24.0 Receive National Bit Buffer (Page 0FH)	153
25.0 AC/DC Electrical Characteristics	154

List of Figures

Figure 1 - MT9076 Functional Block	1
Figure 2 - Pin Connections	3
Figure 3 - Input Jitter Tolerance as Recommended by TR-62411 (T1)	22
Figure 4 - Input Jitter Tolerance as Recommended by G.823 and ETSI 300 011 (E1)	23
Figure 5 - Analog Line Interface	24
Figure 6 - Pulse Template (T1.403)(T1)	25
Figure 7 - Pulse Template (G.703)(E1)	26
Figure 8 - Clock Oscillator Circuit	27
Figure 9 - Crystal Oscillator Circuit	27
Figure 10 - TR 62411 Jitter Attenuation Curve	28
Figure 11 - Read and Write Pointers in the Transmit Slip Buffers	46
Figure 12 - Read and Write Pointers in the Receive Slip Buffers	48
Figure 13 - Read and Write Pointers in the Slip Buffers	49
Figure 14 - Synchronization State Diagram	51
Figure 15 - Motorola Microport Timing	155
Figure 16 - Intel Microport Timing	156
Figure 17 - JTAG Port Timing	157
Figure 18 - Transmit Data Link Timing Diagram (T1 mode)	158
Figure 19 - Transmit Data Link Timing Diagram (E1 mode)	158
Figure 20 - Transmit Data Link Functional Timing (E1 mode)	159
Figure 21 - Receive Data Link Functional Timing (T1 mode)	159
Figure 22 - Receive Data Link Diagram (T1 mode)	160
Figure 23 - Receive Data Link Functional Timing (E1 mode)	160
Figure 24 - Receive Data Link Timing Diagram (E1 mode)	161
Figure 25 - ST-BUS Functional Timing Diagram - 2.048 Mb/s Mode	161
Figure 26 - ST-BUS Functional Timing Diagram - 8.192 Mb/s Mode	162
Figure 27 - ST-BUS Timing Diagram (Input Clocks)	162
Figure 28 - ST-BUS Timing Diagram (Output Clocks)	163
Figure 29 - Receive Multiframe Functional Timing (T1 mode)	163
Figure 30 - Receive Multiframe Functional Timing (E1 mode)	164
Figure 31 - Transmit Multiframe Functional Timing (T1 mode or E1 mode)	164
Figure 32 - Multiframe Timing Diagram (T1 mode or E1 mode)	164
Figure 33 - TXA/TXB Functional Timing (T1 mode)	165
Figure 34 - TXA/TXB Functional Timing (E1 mode)	165
Figure 35 - TXA/TXB Timing Diagram (T1 mode or E1 mode)	165
Figure 36 - Tx IMA Functional Timing (T1 mode)	166
Figure 37 - Rx IMA Functional Timing (T1 mode)	166
Figure 38 - Tx IMA Functional Timing (E1 mode)	167
Figure 39 - Rx IMA Functional Timing (E1 mode)	167
Figure 40 - Tx IMA Timing Diagram (T1 mode or E1 mode)	167
Figure 41 - Rx IMA Timing Diagram (T1 mode or E1 mode)	168
Figure 42 - D4 Format	168
Figure 43 - PCM 30 Format	168
Figure 44 - ST-BUS Stream Format - 2.048 Mb/s	169
Figure 45 - ST-BUS Stream Format 8.192 Mb/s	169

1.0 MT9076 Line Interface Unit (LIU)

1.1 Receiver

The receiver portion of the MT9076 LIU consists of an input signal peak detector, an optional equalizer with separate high pass sections, a smoothing filter, data and clock slicers and a clock extractor. Receive equalization gain can be set manually (i.e., software) or it can be determined automatically by peak detectors.

The output of the receive equalizer is conditioned by a smoothing filter and is passed on to the clock and data slicer. The clock slicer output signal drives a phase locked loop, which generates an extracted clock (Exclk). This extracted clock is used to sample the output of the data comparator.

In T1 mode, the receiver portion of the LIU can recover clock and data from the line signal for loop lengths of 0 - 6000 ft. of 22 AWG cable and tolerate jitter to the maximum specified by AT&T TR 62411(Figure 3).

The LOS output pin function is selectable to indicate any combination of loss of signal and/or loss of basic frame synchronization condition.

The LLOS (Loss of Signal) status bit indicates when the receive signal level is lower than the analog threshold for at least 1 millisecond, or when the number of consecutive received zeros exceeds the digital loss threshold.

In E1 mode, the analog threshold is either of -20 dB or -40 dB. The digital loss threshold is either 32 or 192.

In T1 mode, the receive LIU circuit requires a terminating resistor of 100 Ω across the device side of the receive 1:1 transformer.

In E1 mode, the receive LIU circuit requires a terminating resistor of either 120 Ω or 75 Ω across the device side of the receive 1:1 transformer.

The jitter tolerance of the clock extractor circuit exceeds the requirements of TR 62411 in T1 mode (see Figure 3) and G.823 in E1 mode (see Figure 4).

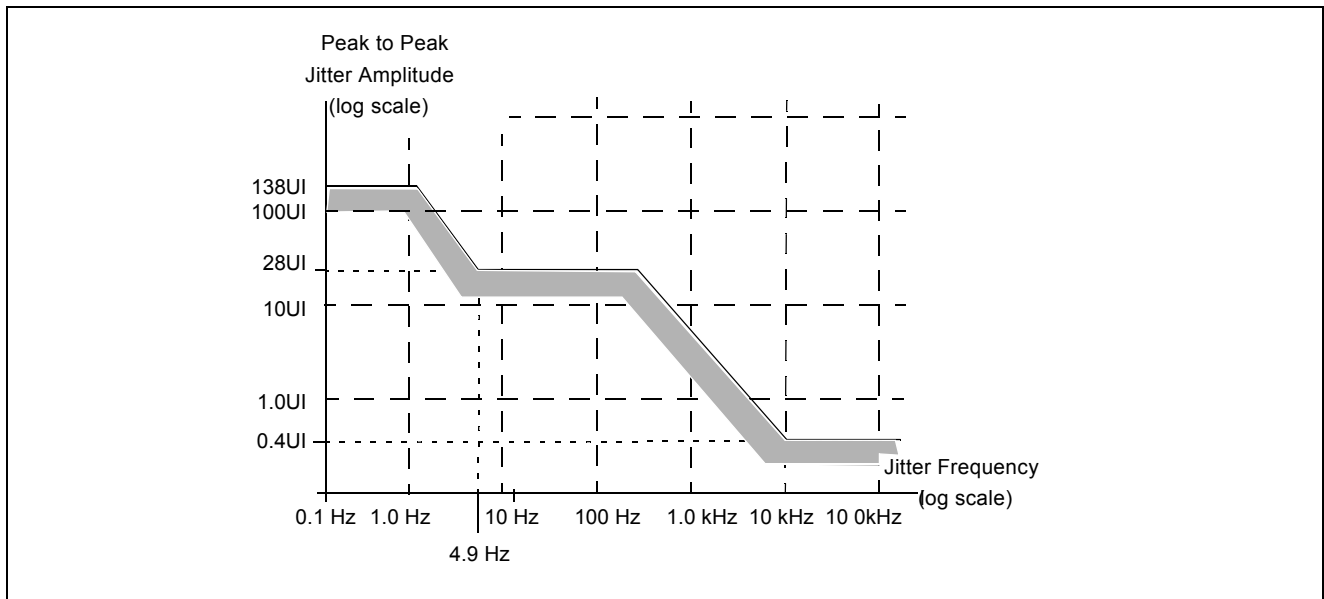

Figure 3 - Input Jitter Tolerance as Recommended by TR-62411 (T1)

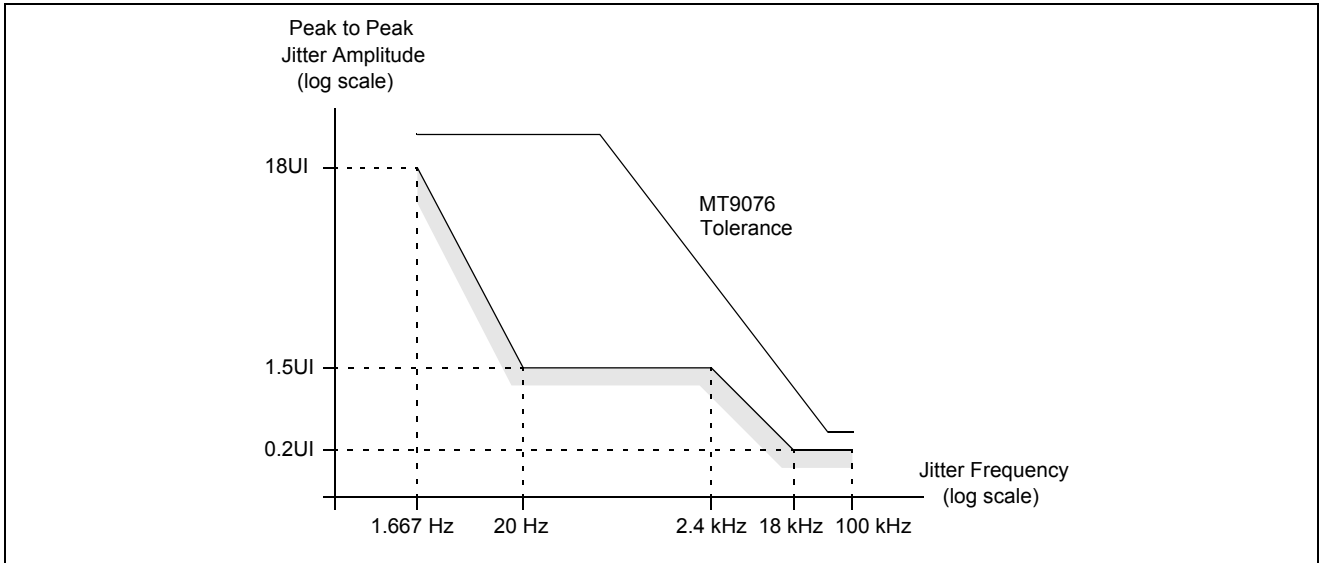

Figure 4 - Input Jitter Tolerance as Recommended by G.823 and ETSI 300 011 (E1)

1.2 Transmitter

The transmit portion of the MT9076 LIU consists of a high speed digital-to-analog converter and complementary line drivers.

When a pulse is to be transmitted, a sequence of digital values (dependent on transmit equalization) are read out of a ROM by a high speed clock. These values drive the digital-to-analog converter to produce an analog signal, which is passed to the complementary line drivers.

The complementary line drivers are designed to drive a 1:2.4 step-up transformer in T1 mode and either a 1:2 or 1:2.4 step-up transformer in E1 mode (see Figure 5). A 0.47 μF capacitor is required between the TTIP and the transmit transformer. Resistors R_T (as shown in Figure 5) are for termination for transmit return loss. The values of R_T may be optimized for T1 mode, E1 120 Ω lines, E1 75 Ω lines or set at a compromise value to serve multiple applications. Program the Tx LIU Control Word (page 02H, address 11H) to adjust the pulse amplitude accordingly.

Alternatively, the pulse level and shape may be discretely programmed by writing to the Custom Pulse Level registers (page 2, addresses 1CH to 1FH) and setting the Custom Transmit Pulse bit high (bit 3 of the Tx LIU Control Word). In this case the output of each of the registers directly drives the D/A converter going to the line driver. Table 1 and Table 2 show recommended transmit pulse amplitude settings.

In T1 mode, the template for the transmitted pulse (the DSX-1 template) is shown in Figure 6. The nominal peak voltage of a mark is 3 volts. The ratio of the amplitude of the transmit pulses generated by TTIP and TRING lie between 0.95 and 1.05.

In E1 mode, the template for the transmitted pulse, as specified in G.703, is shown in Figure 7. The nominal peak voltage of a mark is 3 volts for 120 Ω twisted pair applications and 2.37 volts for 75 Ω coax applications. The ratio of the amplitude of the transmit pulses generated by TTIP and TRING lie between 0.95 and 1.05.

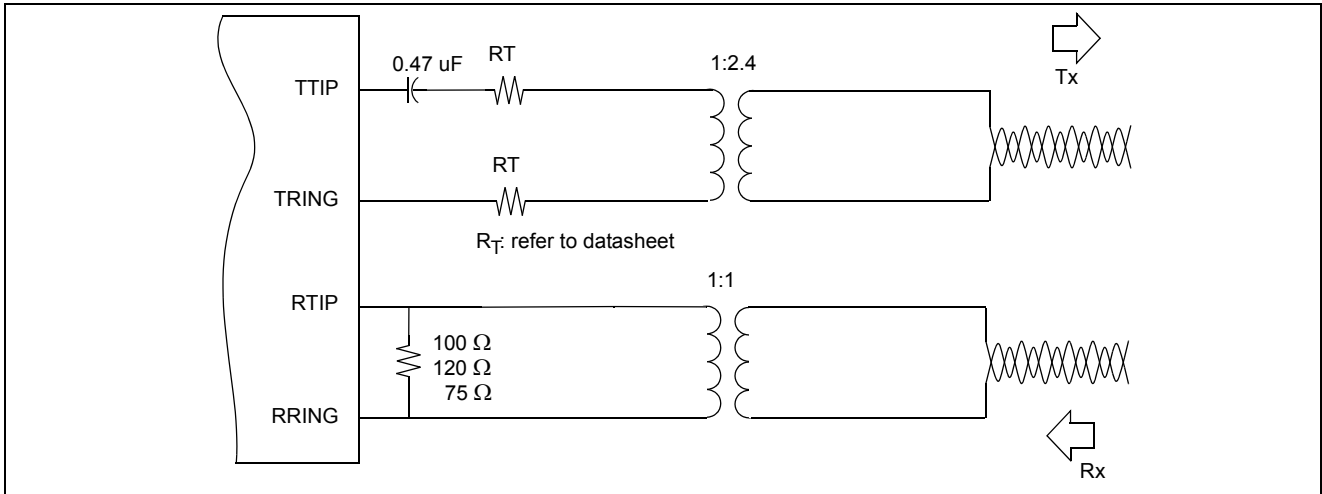

Figure 5 - Analog Line Interface

Notes:

- 1) Protection circuitry (i.e., voltage clamps, line fuses, common mode choke etc.) depends on the application and is not shown. For a reference design, refer to the evaluation board schematic.
- 2) The transformer shown is a Pulse Engineering T1144.

Name	Functional Description																																							
TXL2-0	<p>Transmit Line Build Out 2 - 0. Setting these bits shapes the transmit pulse as detailed in the table below:</p> <table border="1" data-bbox="359 1062 1102 1342"> <thead> <tr> <th>TXL2</th> <th>TXL1</th> <th>TXL0</th> <th>Line Build Out</th> </tr> </thead> <tbody> <tr> <td>0</td> <td>0</td> <td>0</td> <td>0 to 133 feet/ 0 dB</td> </tr> <tr> <td>0</td> <td>0</td> <td>1</td> <td>133 to 266 feet</td> </tr> <tr> <td>0</td> <td>1</td> <td>0</td> <td>266 to 399 feet</td> </tr> <tr> <td>0</td> <td>1</td> <td>1</td> <td>399 to 533 feet</td> </tr> <tr> <td>1</td> <td>0</td> <td>0</td> <td>533 to 655 feet</td> </tr> <tr> <td>1</td> <td>0</td> <td>1</td> <td>-7.5 dB</td> </tr> <tr> <td>1</td> <td>1</td> <td>0</td> <td>-15 dB</td> </tr> <tr> <td>1</td> <td>1</td> <td>1</td> <td>-22.5 dB</td> </tr> </tbody> </table> <p>After reset these bits are zero.</p>				TXL2	TXL1	TXL0	Line Build Out	0	0	0	0 to 133 feet/ 0 dB	0	0	1	133 to 266 feet	0	1	0	266 to 399 feet	0	1	1	399 to 533 feet	1	0	0	533 to 655 feet	1	0	1	-7.5 dB	1	1	0	-15 dB	1	1	1	-22.5 dB
TXL2	TXL1	TXL0	Line Build Out																																					
0	0	0	0 to 133 feet/ 0 dB																																					
0	0	1	133 to 266 feet																																					
0	1	0	266 to 399 feet																																					
0	1	1	399 to 533 feet																																					
1	0	0	533 to 655 feet																																					
1	0	1	-7.5 dB																																					
1	1	0	-15 dB																																					
1	1	1	-22.5 dB																																					

Table 1 - Transmit Line Build Out (T1)

	Name	Functional Description																																																															
WR	Winding Ratio.	Set this pin low if a 1:2.4 transformer is used on the transmit side. Set this pin high if a 1:2 transformer is used.																																																															
TX2-0	Transmit pulse amplitude.	<p>Select the TX2 –TX0 bits according to the line type, value of termination resistors (RT), and transformer turns ratio used.</p> <table border="1" data-bbox="311 416 1437 694"> <thead> <tr> <th>TX2</th> <th>TX1</th> <th>TX0</th> <th>Line Impedance (ohms)</th> <th>RT(ohms)</th> <th>Transformer Ratio</th> <th>WR (bit 7)</th> </tr> </thead> <tbody> <tr><td>0</td><td>0</td><td>0</td><td>120</td><td>0</td><td>1:2.4</td><td>0</td></tr> <tr><td>0</td><td>0</td><td>1</td><td>120</td><td>6.8</td><td>1:2.4</td><td>0</td></tr> <tr><td>0</td><td>1</td><td>0</td><td>120</td><td>6.8</td><td>1:2.4</td><td>0</td></tr> <tr><td>0</td><td>1</td><td>1</td><td>75</td><td>5.1</td><td>1:2.4</td><td>0</td></tr> <tr><td>1</td><td>0</td><td>0</td><td>-</td><td>-</td><td>-</td><td>-</td></tr> <tr><td>1</td><td>0</td><td>1</td><td>75</td><td>6</td><td>1:2</td><td>1</td></tr> <tr><td>1</td><td>1</td><td>0</td><td>75</td><td>6</td><td>1:2</td><td>1</td></tr> <tr><td>1</td><td>1</td><td>1</td><td>75</td><td>5.1</td><td>1:2.4</td><td>0</td></tr> </tbody> </table> <p>After reset, these bits are zero.</p>	TX2	TX1	TX0	Line Impedance (ohms)	RT(ohms)	Transformer Ratio	WR (bit 7)	0	0	0	120	0	1:2.4	0	0	0	1	120	6.8	1:2.4	0	0	1	0	120	6.8	1:2.4	0	0	1	1	75	5.1	1:2.4	0	1	0	0	-	-	-	-	1	0	1	75	6	1:2	1	1	1	0	75	6	1:2	1	1	1	1	75	5.1	1:2.4	0
TX2	TX1	TX0	Line Impedance (ohms)	RT(ohms)	Transformer Ratio	WR (bit 7)																																																											
0	0	0	120	0	1:2.4	0																																																											
0	0	1	120	6.8	1:2.4	0																																																											
0	1	0	120	6.8	1:2.4	0																																																											
0	1	1	75	5.1	1:2.4	0																																																											
1	0	0	-	-	-	-																																																											
1	0	1	75	6	1:2	1																																																											
1	1	0	75	6	1:2	1																																																											
1	1	1	75	5.1	1:2.4	0																																																											

Table 2 - Transmit Pulse Amplitude (E1)

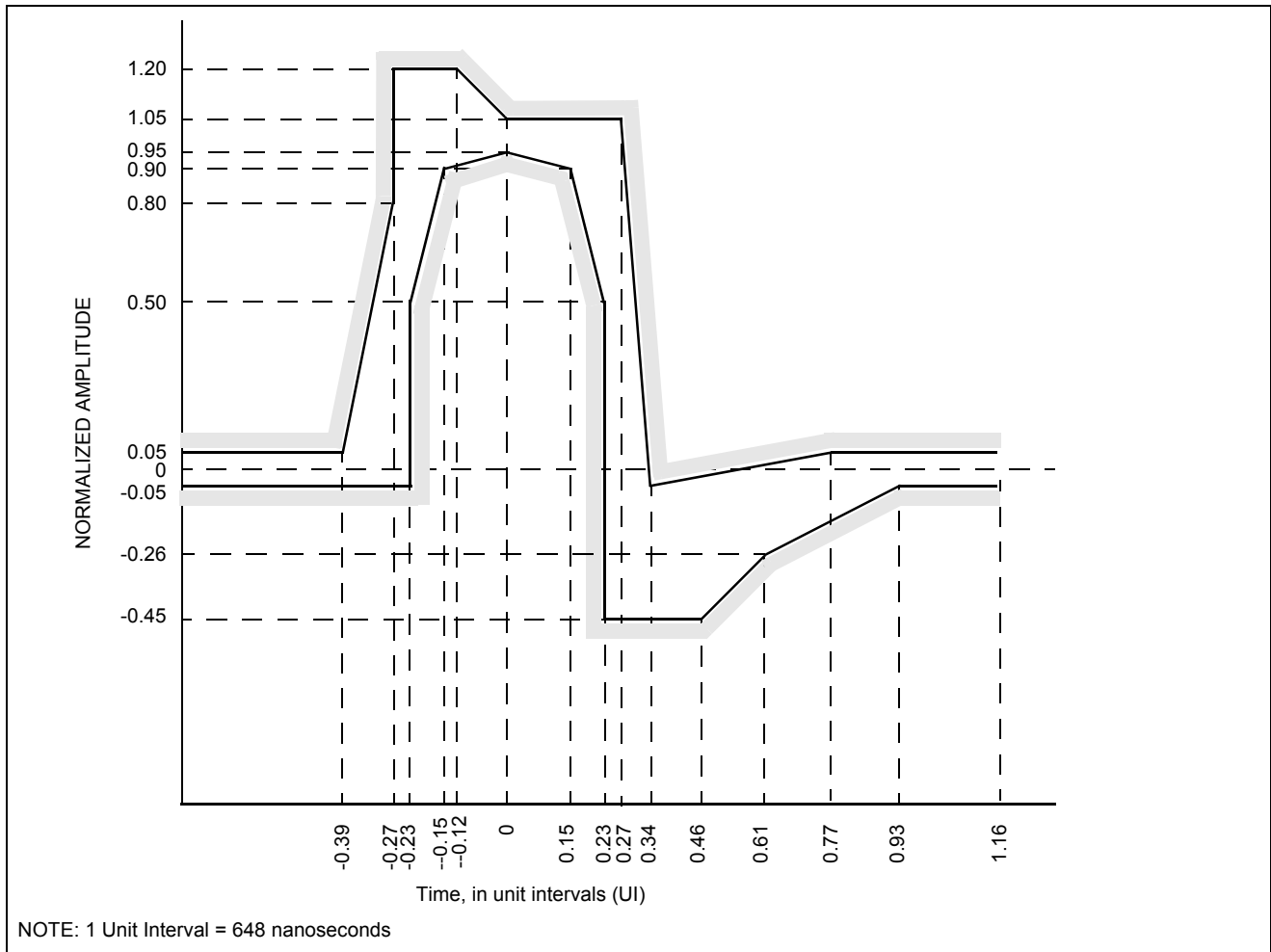

Figure 6 - Pulse Template (T1.403)(T1)

Time (Nanoseconds)	-499	-253	-175	-175	-78	0	175	220	499	752	---	---
Time U.I.	-.77	-.39	-.27	-.27	-.12	0	.27	.34	.77	1.16	---	---
Normalized Amplitude	.05	.05	.8	1.2	1.2	1.05	1.05	-.05	.05	.05	---	---

Table 3 - Maximum Curve for Figure 5

Time (Nanoseconds)	-499	-149	-149	-97	0	97	149	149	298	395	603	752
Time U.I.	-.77	-.23	-.23	-.15	0	.15	.23	.23	.46	.61	.93	1.16
Normalized Amplitude	-.05	-.05	.5	.9	.95	.9	.5	-.45	-.45	-.26	-.05	-.05

Table 4 - Minimum Curve for Figure 5

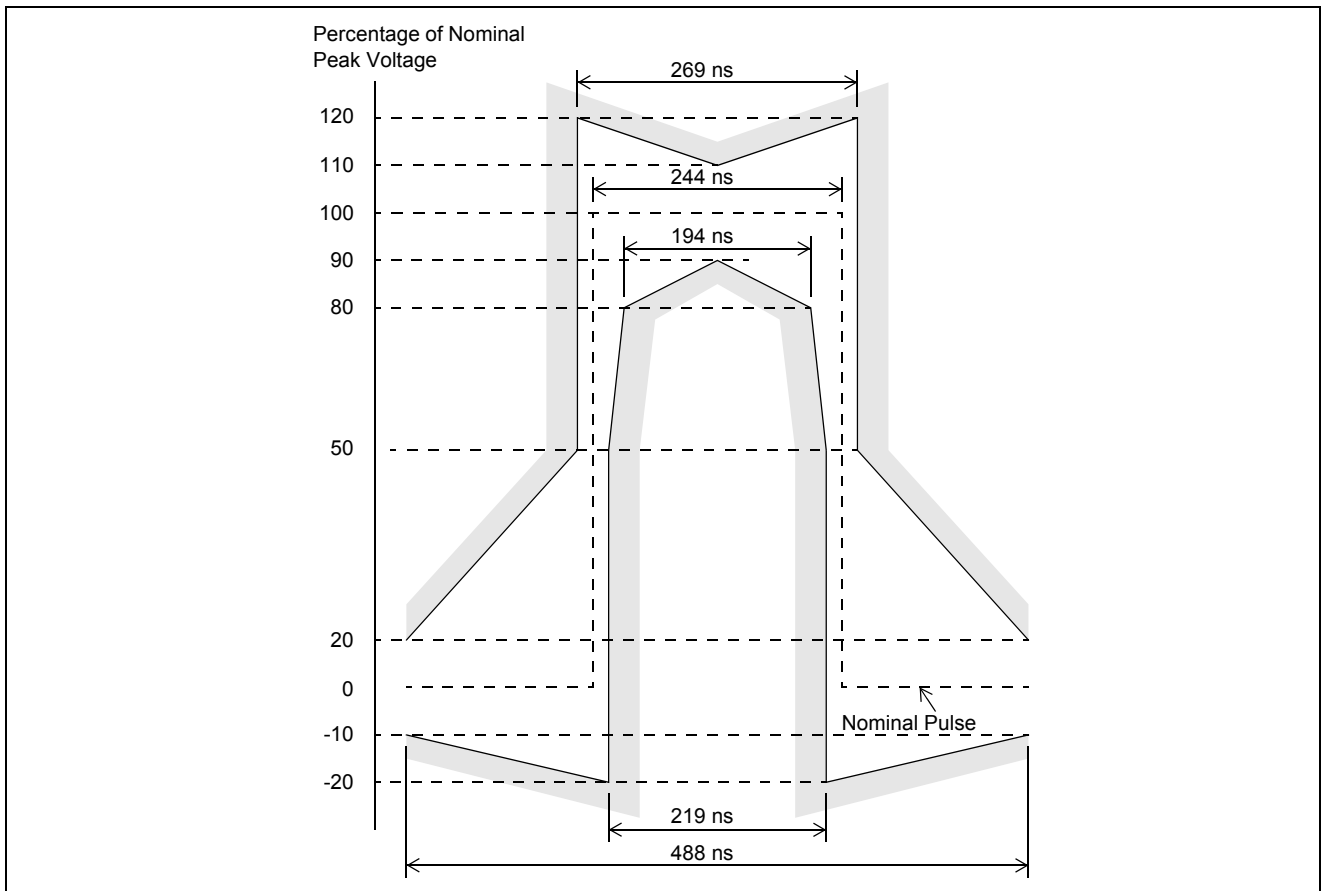

Figure 7 - Pulse Template (G.703)(E1)

1.3 20 MHz Clock

The MT9076 requires a 20 MHz clock. This may be provided by a 50 ppm oscillator as per Figure 8.

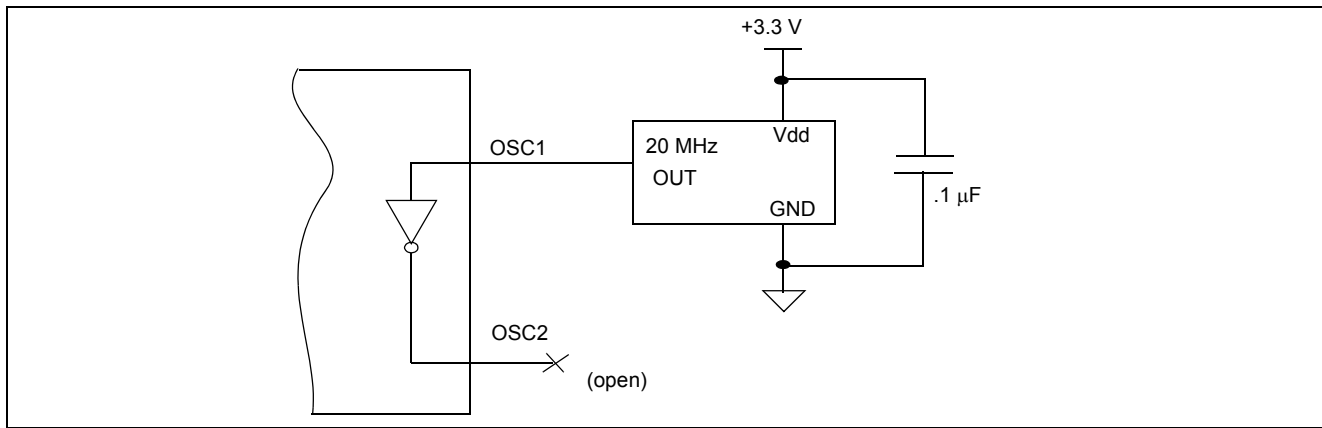

Figure 8 - Clock Oscillator Circuit

Alternatively, a crystal oscillator may be used. A complete oscillator circuit made up of a crystal, resistors and capacitors is shown in Figure 9. The crystal specification is as follows.

<i>Frequency:</i>	20 MHz
<i>Tolerance:</i>	50 ppm
<i>Oscillation Mode:</i>	Fundamental
<i>Resonance Mode:</i>	Parallel
<i>Load Capacitance:</i>	32 pF
<i>Maximum Series Resistance:</i>	35 Ω
<i>Approximate Drive Level:</i>	1 mW

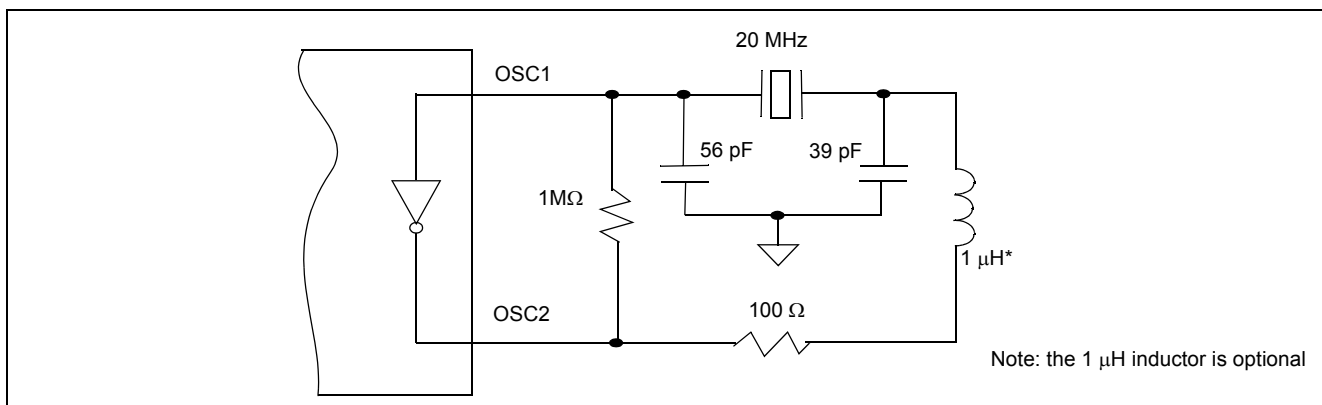

Figure 9 - Crystal Oscillator Circuit

1.4 Phase Lock Loop (PLL)

The MT9076 contains a PLL, which can be locked to either an input 4.096 MHz clock or the extracted line clock. The PLL will attenuate jitter from less than 2.5 Hz and roll-off at a rate of 20 dB/decade. Its intrinsic jitter is less than 0.02 UI. The PLL will meet the jitter transfer characteristics as specified by AT&T document TR 62411 and the relevant recommendations as shown in Figure 3.

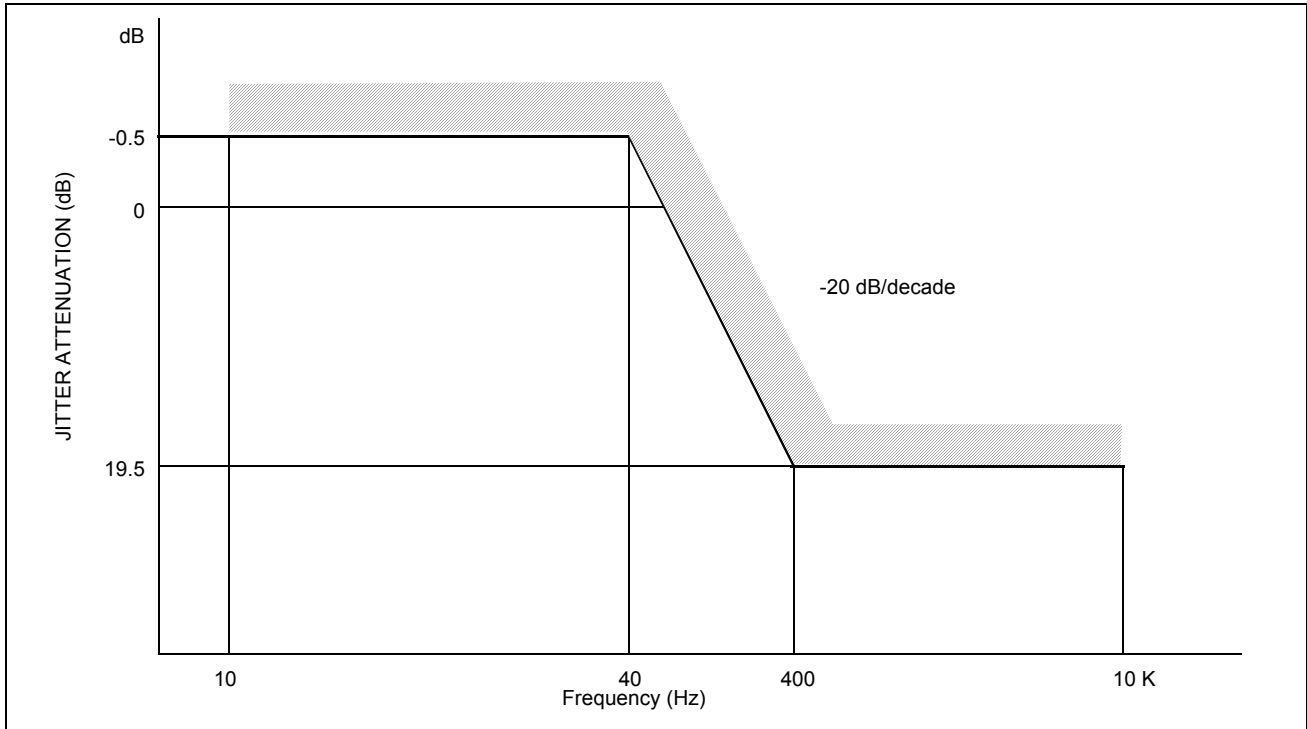

Figure 10 - TR 62411 Jitter Attenuation Curve

2.0 Clock Jitter Attenuation Modes

MT9076 has three basic jitter attenuation modes of operation, selected by the $\overline{BS/LS}$ and $\overline{S/FR/Exclki}$ control pins.

- System Bus Synchronous Mode
- Line Synchronous Mode
- Free-run mode

Depending on the mode selection above, the PLL can either attenuate transmit clock jitter or the receive clock jitter. Table 5 shows the appropriate configuration of each control pin to achieve the appropriate mode and Jitter attenuation capability of the MT9076.

Mode Name	$\overline{BS/LS}$	$\overline{S/FR/Exclki}$	Note
System Bus Synchronous	1	1	PLL locked to $\overline{C4b}$
Line Synchronous	0	1	PLL locked to Exclk
Free-Run	x	0	PLL free - running

Table 5 - Selection of Clock Jitter Attenuation Modes using the $\overline{M/S}$ and $\overline{MS/FR}$ Pins

In System Bus Synchronous mode, pins $\overline{C4b}$ and $\overline{F0b}$ are always configured as inputs, while in the Line Synchronous and Free-Run modes $\overline{C4b}$ and $\overline{F0b}$ are configured as outputs.

Referring to the mode names given in Table 5 the basic operation of the jitter attenuation modes are:

- In *System Bus Synchronous* mode an external clock is applied to $\overline{C4b}$. The applied clock is dejittered by the internal PLL before being used to synchronize the transmitted data. The clock extracted (with no jitter attenuation performed) from the receive data can be monitored on pin Exclk.

- In *Line Synchronous mode*, the clock extracted from the receive data is dejittered using the internal PLL and then output on pin $\overline{C4b}$. Pin Exclk provides the extracted receive clock before it has been dejittered. The transmit data is synchronous to the clean receive clock.
- In *Free-Run mode* the transmit data is synchronized to the internally generated clock. The internal clock is output on pin $\overline{C4b}$. The clock signal extracted from the receive data is not dejittered and is output directly on Exclk.

2.1 Jitter Attenuator FIFO

In System Bus Synchronous operation, a data buffer is required between the jittered input clock and the clean transmit clock. In normal T1 mode, the transmit slip buffer performs this function. In T1 IMA mode, the transmit slip buffer is unused, instead a jitter attenuator FIFO is employed. In an E1 mode System Bus Synchronous configuration, the jitter attenuator FIFO is always used. In this case the $\overline{C4b}$ signal clocks the data into the FIFO, the PLL de-jitters the $\overline{C4b}$ clock and the resulting clean $\overline{C4b}$ signal clocks the data out of the FIFO.

The JA meets the jitter transfer characteristics as proposed by ETSI ETS 300 011, G.735 and the relevant recommendations as shown in Figure 10. The JA FIFO depth can be selected to be from 16 to 128 words deep, in multiples of 16 (2-bit) words. Its read pointer can be centered by changing the JFC bit (address 13H of page 02H) to provide maximum jitter tolerance. If the read pointer should come within 4 bits of either end of the FIFO, the read clock frequency will be increased or decreased by 0.0625 UI to correct the situation. The maximum time needed to centre is $T_{max} = 3904 * \text{Depth ns}$, where Depth is the selected JA FIFO depth. During this time the JA will not attenuate jitter.

2.2 IMA Mode

2.2.1 T1 Mode

In T1 IMA Mode, neither the transmit nor the receive slip buffers are activated. Channel Associated signaling (CAS) and HDLC operation is not supported. The input pin $\overline{C4b}$ accepts a 1.544 MHz clock and it clocks incoming data from DSTi into a jitter attenuator FIFO. This clock is dejittered with the internal PLL. The dejittered clock clocks data out of the FIFO for transmission onto the line. Receive clock (1.544 MHz) and data is extracted from the line and routed to pins Exclk and DSTo respectively. The receive clock Exclk is not dejittered before being driven off chip. For operation in IMA mode, the MT9076 should be programmed in System Bus Synchronous mode (BS/LS and S/FR/Exclki set high).

2.2.2 E1 Mode

In E1 IMA Mode neither the transmit nor the receive slip buffers are activated. The input pin $\overline{C4b}$ accepts a 2.048 MHz clock and it clocks incoming data from DSTi into a jitter attenuator FIFO. This clock is dejittered with the internal PLL. The dejittered clock clocks data out of the FIFO for transmission onto the line. Receive clock (2.048 MHz) and data is extracted from the line and routed to pins Exclk and DSTo respectively. The receive clock Exclk is not dejittered before being driven off chip. For operation in IMA mode, the MT9076 should be programmed in System Bus Synchronous mode (BS/LS and S/FR/Exclki set high).

3.0 The Digital Interface

3.1 T1 Digital Interface

In T1 mode, DS1 frames are 193 bits long and are transmitted at a frame repetition rate of 8000 Hz, which results in an aggregate bit rate of 193 bits x 8000/sec = 1.544 Mbits/sec. The actual bit rate is 1.544 Mbits/sec +/-50 ppm optionally encoded in B8ZS format. The Zero Suppression control register (page 1, address 15H,) selects either B8ZS encoding, forced one stuffing or alternate mark inversion (AMI) encoding. Basic frames are divided into 24 time slots numbered 1 to 24. Each time slot is 8 bits in length and is transmitted most significant bit first (numbered bit 1). This results in a single time slot data rate of 8 bits x 8000/sec. = 64 kbits/sec.

It should be noted that the Zarlink ST-BUS has 32 channels numbered 0 to 31. When mapping to the DS1 payload only the first 24 time slots and the last (time slot 31, for the overhead bit) of an ST-BUS are used (see Table 6). All unused channels are tristate.

When signaling information is written to the MT9076 in T1 mode using ST-BUS control links (as opposed to direct writes by the microport to the on-board signaling registers), the CSTi channels corresponding to the selected DSTi channels streams are used to transmit the signaling bits.

Since the maximum number of signaling bits associated with any channel is 4 (in the case of ABCD), only half a CSTi channel is required for sourcing the signaling bits. The choice of which half of the channel to use is selected by the control bit MSN (page 01H address 14H). The same control bit selects which half of the CSTo channel will contain receive signaling information (the other nibble in the channel being tristate). Unused channels are tristate.

The most significant bit of an eight bit ST-BUS channel is numbered bit 7 (see Zarlink Application Note MSAN-126). Therefore, ST-BUS bit 7 is synonymous with DS1 bit 1; bit 6 with bit 2: and so on.

DS1 Timeslots	1	2	3	4	5	6	7	8	9	10	11	12	13	14	15	16
Voice/Data Channels (DSTi/o and CSTi/o)	0	1	2	3	4	5	6	7	8	9	10	11	12	13	14	15
DS1 Timeslots	17	18	19	20	21	22	23	24	-	-	-	-	-	-	-	-
Voice/Data Channels (DSTi/o and CSTi/o)	16	17	18	19	20	21	22	23	24	25	26	27	28	29	30	31 Sbit

Table 6 - ST-BUS vs. DS1 to Channel Relationship(T1)

3.2 Frame and Superframe Structure in T1 Mode

3.2.1 Multiframing

In T1 mode, DS1 trunks contain 24 bytes of serial voice/data channels bundled with an overhead bit. The frame overhead bit contains a fixed repeating pattern used to enable DS1 receivers to deliniate frame boundaries. Overhead bits are inserted once per frame at the beginning of the transmit frame boundary. The DS1 frames are further grouped in bundles of frames, generally 12 (for D4 applications) or 24 frames (for ESF - extended superframe applications) deep. Table 7 and Table 8 illustrate the D4 and ESF frame structures respectively.

For D4 links the frame structure contains an alternating 101010... pattern inserted into every second overhead bit position. These bits are intended for determination of frame boundaries, and they are referred to as Ft bits. A separate fixed pattern, repeating every superframe, is interleaved with the Ft bits. This fixed pattern (001110), is used to deliniate the 12 frame superframe. These bits are referred to as the Fs bits. In D4 frames # 6 and #12, the LSB of each channel byte may be replaced with A bit (frame #6) and B bit (frame #12) signaling information.

For ESF links the 6 bit framing pattern 001011, inserted into every 4th overhead bit position, is used to deliniate both frame and superframe boundaries. Frames #6, 12, 18 and 24 contain the A, B, C and D signaling bits, respectively. A 4 kHz data link is embedded in the overhead bit position, interleaved between the framing pattern sequence (FPS) and the transmit CRC-6 remainder (from the calculation done on the previous superframe), see Table 8.

The SLC-96 frame structure is similar to the D4 frame structure, except a facility management overlay is superimposed over the erstwhile Fs bits, see Table 9.

The protocol appropriate for the application is selected via the Framing Mode Selection Word, address 10H of Master Control page 1. In T1 mode, MT9076 is capable of generating the overhead bit framing pattern and (for ESF links) the CRC remainder for transmission onto the DS1 trunk. The beginning of the transmit multiframe may be determined by any of the following criteria:

- (i) It may free - run with the internal multiframe counters;
- (ii) The multiframe counters may be reset with the external hardware pin $\overline{\text{TxMF}}$. If this signal is not synchronous with the current transmit frame count it may cause the far end to go temporarily out of sync.
- (iii) Under software control (by setting the TxSYNC bit in page 01 address 12H) the transmit multiframe counters will be synchronized to the framing pattern present in the overhead bits multiplexed into channel 31 bit 0 of the incoming 2.048 Mb/s digital stream DSTi. Note that the overhead bits extracted from the receive signal are multiplexed into outgoing DSTo channel 31 bit 0.
- (iv) In SLC - 96 mode the transmit frame counters synchronize to the framing pattern clocked in on the TXDL input

Frame #	Ft	Fs	Signaling
1	1		
2		0	
3	0		
4		0	
5	1		
6		1	A
7	0		
8		1	
9	1		
10		1	
11	0		
12		0	B

Table 7 - D4 Superframe Structure(T1)

Frame #	FPS	FDL	CRC	Signaling
1		X		
2			CB1	
3		X		
4	0			
5		X		
6			CB2	A
7		X		
8	0			
9		X		
10			CB3	
11		X		
12	1			B
13		X		
14			CB4	
15		X		
16	0			
17		X		
18			CB5	C
19		X		
20	1			

Table 8 - ESF Superframe Structure (T1)

Frame #	FPS	FDL	CRC	Signaling
21		X		
22			CB6	
23		X		
24	1			D

Table 8 - ESF Superframe Structure (T1) (continued)

Frame #	Ft	Fs	Notes	Frame #	Ft	Fs	Notes	Frame #	Ft	Fs	Notes
1	1			25	1		C	49	1		
2		0	R	26		X	o	50		S	S = Spoiler Bits
3	0		e	27	0		n	51	0		
4		0	s	28		X	c	52		S	
5	1		y	29	1		e	53	1		
6		0	n	30		X	n	54		C	C = Maintenance Field Bits
7	0		c	31	0		t	55	0		
8		1	h	32		X	r	56		C	
9	1		r	33	1		a	57	1		
10		1	o	34		X	t	58		C	
11	0		n	35	0		o	59	0		
12		1	i	36		X	r	60		A	A = Alarm Field Bits
13	1		z	37	1			61	1		
14		0	a	38		X	F	62		A	
15	0		t	39	0		i	63	0		
16		0	i	40		X	e	64		L	L = Line Switch Field Bits
17	1		o	41	1		l	65	1		
18		0	n	42		X	d	66		L	
19	0			43	0			67	0		
20		1	d	44		X	B	68		L	
21	1		a	45	1		i	69	1		
22		1	t	46		X	t	70		L	
23	0		a	47	0		s	71	0		
24		1		48		S		72		S	S = Spoiler Bits

Table 9 - SLC-96 Framing Structure(T1)

3.3 E1 Digital Interface

PCM 30 (E1) basic frames are 256 bits long and are transmitted at a frame repetition rate of 8000 Hz, which results in an aggregate bit rate of 256 bits x 8000/sec = 2.048 Mbits/sec. The actual bit rate is 2.048 Mbits/sec +/-50 ppm encoded in HDB3 format. The HDB3 control bit (page 01H, address 15H, bit 5) selects either HDB3 encoding or alternate mark inversion (AMI) encoding. Basic frames are divided into 32 time slots numbered 0 to 31, see Figure 43 on page 168. Each time slot is 8 bits in length and is transmitted most significant bit first (numbered bit 1). This results in a single time slot data rate of 8 bits x 8000/sec. = 64 kbits/sec.

It should be noted that the Zarlink ST-BUS also has 32 channels numbered 0 to 31, but the most significant bit of an eight bit channel is numbered bit 7 (see Zarlink Application Note MSAN-126). Therefore, ST-BUS bit 7 is synonymous with PCM 30 bit 1; bit 6 with bit 2: and so on (Figure 44).

PCM 30 time slot 0 is reserved for basic frame alignment, CRC-4 multiframe alignment and the communication of maintenance information. In most configurations time slot 16 is reserved for either Channel Associated signaling

(CAS or ABCD bit signaling) or Common Channel signaling (CCS). The remaining 30 time slots are called channels and carry either PCM encoded voice signals or digital data. Channel alignment and bit numbering is consistent with time slot alignment and bit numbering. However, channels are numbered 1 to 30 and relate to time slots as per Table 10.

PCM 30 Timeslots	0	1,2,3...15	16	17,18,19,... 31
Voice/Data Channels (DSTi/o and CSTi/o)	0	1,2,3...15	16	17,18,19,... 31

Table 10 - ST-BUS vs. PCM-30 to Channel Relationship(E1)

3.3.1 Basic Frame Alignment

Time slot 0 of every basic frame is reserved for basic frame alignment and contains either a Frame Alignment Signal (FAS) or a Non-Frame Alignment Signal (NFAS). FAS and NFAS occur in time slot zero of consecutive basic frames as shown in Table 10. Bit two is used to distinguish between FAS (bit two = 0) and NFAS (bit two = 1).

Basic frame alignment is initiated by a search for the bit sequence 0011011 which appears in the last seven bit positions of the FAS, see the Frame Algorithm section. Bit position one of the FAS can be either a CRC-4 remainder bit or an international usage bit.

Bits four to eight of the NFAS (i.e., S_{a4} - S_{a8}) are additional spare bits which may be used as follows:

- S_{a4} to S_{a8} may be used in specific point-to-point applications (e.g., transcoder equipments conforming to G.761)
- S_{a4} may be used as a message-based data link for operations, maintenance and performance monitoring
- S_{a5} to S_{a8} are for national usage

A maintenance channel or data link at 4,8,12,16,or 20 kHz for selected S_a bits is provided by the MT9076 in E1 mode to implement these functions. Note that for simplicity all S_a bits including S_{a4} are collectively called national bits throughout this document.

Bit three (designated as "A"), the Remote Alarm Indication (RAI), is used to indicate the near end basic frame synchronization status to the far end of a link. Under normal operation, the A (RAI) bit should be set to 0, while in alarm condition, it is set to 1.

Bit position one of the NFAS can be either a CRC-4 multiframe alignment signal, an E-bit or an international usage bit. Refer to an approvals laboratory and national standards bodies for specific requirements.

CRC	CRC Frame/Type	PCM 30 Channel Zero							
		1	2	3	4	5	6	7	8
Sub Multi Frame 1	0/FAS	C ₁	0	0	1	1	0	1	1
	1/NFAS	0	1	A	S _{a4}	S _{a5}	S _{a6}	S _{a7}	S _{a8}
	2/FAS	C ₂	0	0	1	1	0	1	1
	3/NFAS	0	1	A	S _{a4}	S _{a5}	S _{a6}	S _{a7}	S _{a8}
	4/FAS	C ₃	0	0	1	1	0	1	1
	5/NFAS	1	1	A	S _{a4}	S _{a5}	S _{a6}	S _{a7}	S _{a8}
	6/FAS	C ₄	0	0	1	1	0	1	1
Sub Multi Frame 2	7/NFAS	0	1	A	S _{a4}	S _{a5}	S _{a6}	S _{a7}	S _{a8}
	8/FAS	C ₁	0	0	1	1	0	1	1
	9/NFAS	1	1	A	S _{a4}	S _{a5}	S _{a6}	S _{a7}	S _{a8}
	10/FAS	C ₂	0	0	1	1	0	1	1
	11/NFAS	1	1	A	S _{a4}	S _{a5}	S _{a6}	S _{a7}	S _{a8}
	12/FAS	C ₃	0	0	1	1	0	1	1
	13/NFAS	E ₁	1	A	S _{a4}	S _{a5}	S _{a6}	S _{a7}	S _{a8}
	14/FAS	C ₄	0	0	1	1	0	1	1
15/NFAS	E ₂	1	A	S _{a4}	S _{a5}	S _{a6}	S _{a7}	S _{a8}	

Table 11 - FAS and NFAS Structure

 indicates position of CRC-4 multiframe alignment sign:

3.3.2 CRC-4 Multiframing in E1 Mode

The primary purpose for CRC-4 multiframing is to provide a verification of the current basic frame alignment, although it can also be used for other functions such as bit error rate estimation. The CRC-4 multiframe consists of 16 basic frames numbered 0 to 15, and has a repetition rate of 16 frames X 125 microseconds/frame = 2 msec.

CRC-4 multiframe alignment is based on the 001011 bit sequence, which appears in bit position one of the first six NFASs of a CRC-4 multiframe.

The CRC-4 multiframe is divided into two submultiframes, numbered 1 and 2, which are each eight basic frames or 2048 bits in length.

The CRC-4 frame alignment verification functions as follows. Initially, the CRC-4 operation must be activated and CRC-4 multiframe alignment must be achieved at both ends of the link. At the local end of a link, all the bits of every transmit submultiframe are passed through a CRC-4 polynomial (multiplied by X^4 then divided by $X^4 + X + 1$), which generates a four bit remainder. This remainder is inserted in bit position one of the four FASs of the following submultiframe before it is transmitted (see Table 12).

The submultiframe is then transmitted and, at the far end, the same process occurs. That is, a CRC-4 remainder is generated for each received submultiframe. These bits are compared with the bits received in position one of the four FASs of the next received submultiframe. This process takes place in both directions of transmission.

When more than 914 CRC-4 errors (out of a possible 1000) are counted in a one second interval, the framing algorithm will force a search for a new basic frame alignment. See Frame Algorithm section for more details.

The result of the comparison of the received CRC-4 remainder with the locally generated remainder will be transported to the far end by the E-bits. Therefore, if $E_1 = 0$, a CRC-4 error was discovered in a submultiframe 1 received at the far end; and if $E_2 = 0$, a CRC-4 error was discovered in a submultiframe 2 received at the far end.

No submultiframe sequence numbers or re-transmission capabilities are supported with layer 1 PCM 30 protocol. See ITU-T G.704 and G.706 for more details on the operation of CRC-4 and E-bits.

There are two CRC multiframe alignment algorithm options selected by the $\overline{\text{AUTC}}$ control bit (address 10H, page 01H). When $\overline{\text{AUTC}}$ is zero, automatic CRC-to-non-CRC interworking is selected. When $\overline{\text{AUTC}}$ is one and $\overline{\text{ARAI}}$ is low, if CRC-4 multiframe alignment is not found in 400 msec, the transmit RAI will be continuously high until CRC-4 multiframe alignment is achieved.

The control bit for transmit E bits (TE, address 11H of page 01H) will have the same function in both states of $\overline{\text{AUTC}}$. That is, when CRC-4 synchronization is not achieved the state of the transmit E-bits will be the same as the state of the TE control bit. When CRC-4 synchronization is achieved the transmit E-bits will function as per ITU-T G.704. Table 12 outlines the operation of the $\overline{\text{AUTC}}$, $\overline{\text{ARAI}}$ and $\overline{\text{TALM}}$ control bits of the MT9076.

$\overline{\text{AUTC}}$	$\overline{\text{ARAI}}$	$\overline{\text{TALM}}$	Description
0	0	X	Automatic CRC-interworking is activated. If no valid CRC MFAS is being received, transmit RAI will flicker high with every reframe (8 msec.), this cycle will continue for 400 msec., then transmit RAI will be low continuously. The device will stop searching for CRC MFAS, continue to transmit CRC-4 remainders, stop CRC-4 processing, indicate CRC-to-non-CRC operation and transmit E-bits to be the same state as the TE control bit (page 01H, address 16H).
0	1	0	Automatic CRC-interworking is activated. Transmit RAI is low continuously.
0	1	1	Automatic CRC-interworking is activated. Transmit RAI is high continuously.
1	0	X	Automatic CRC-interworking is de-activated. If no valid CRC MFAS is being received, transmit RAI flickers high with every reframe (8 msec.), this cycle continues for 400 msec, then transmit RAI becomes high continuously. The device continues to search for CRC MFAS and transmit E-bits are the same state as the TE control bit. When $\text{CRCSYN} = 0$, the CRC MFAS search is terminated and the transmit RAI goes low.
1	1	0	Automatic CRC-interworking is de-activated. Transmit RAI is low continuously.
1	1	1	Automatic CRC-interworking is de-activated. Transmit RAI is high continuously.

Table 12 - Operation of $\overline{\text{AUTC}}$, $\overline{\text{ARAI}}$ and $\overline{\text{TALM}}$ Control Bits (E1 Mode)

3.3.3 CAS Signaling Multiframe in E1 Mode

The purpose of the signaling multiframe algorithm is to provide a scheme that will allow the association of a specific ABCD signaling nibble with the appropriate PCM 30 channel. Time slot 16 is reserved for the communication of Channel Associated signaling (CAS) information (i.e., ABCD signaling bits for up to 30 channels). Refer to ITU-T G.704 and G.732 for more details on CAS multiframe requirements.

A CAS signaling multiframe consists of 16 basic frames (numbered 0 to 15), which results in a multiframe repetition rate of 2 msec. It should be noted that the boundaries of the signaling multiframe may be completely distinct from those of the CRC-4 multiframe. CAS multiframe alignment is based on a multiframe alignment signal (a 0000 bit sequence), which occurs in the most significant nibble of time slot 16 of basic frame 0 of the CAS multiframe. Bit 6 of this time slot is the multiframe alarm bit (usually designated Y). When CAS multiframe is acquired on the receive side, the transmit Y-bit is zero; when CAS multiframe is not acquired, the transmit Y-bit is one. Bits 5, 7 and 8 (usually designated X) are spare bits and are normally set to one if not used.

Time slot 16 of the remaining 15 basic frames of the CAS multiframe (i.e., basic frames 1 to 15) are reserved for the ABCD signaling bits for the 30 payload channels. The most significant nibbles are reserved for channels 1 to 15 and the least significant nibbles are reserved for channels 16 to 30. That is, time slot 16 of basic frame 1 has ABCD for channel 1 and 16, time slot 16 of basic frame 2 has ABCD for channel 2 and 17, through to time slot 16 of basic frame 15 has ABCD for channel 15 and 30.

4.0 MT9076 Access and Control

4.1 The Control Port Interface

The control and status registers of the MT9076 are accessible through a non-multiplexed parallel microprocessor port. The parallel port may be configured for Motorola style control signals (by setting pin INT/MOT low) or Intel style control signals (by setting pin INT/MOT high).

4.2 Control and Status Register Access

The controlling microprocessor gains access to specific registers of the MT9076 through a two step process. First, writing to the Command/Address Register (CAR) selects one of the 15 pages of control and status registers (CAR address: AC4 = 0, AC3-AC0 = don't care, CAR data D7 - D0 = page number). Second, each page has a maximum of 16 registers that are addressed on a read or write to a non-CAR address (non-CAR: address AC4 = 1, AC3-AC0 = register address, D7-D0 = data). Once a page of memory is selected, it is only necessary to write to the CAR when a different page is to be accessed. See the AC Electrical Characteristics section.

Page Address D ₇ - D ₀	Register Description	Processor Access	ST-BUS Access
00000001 (01H)	Master Control	R/W	---
00000010 (02H)		R/W	
00000011 (03H)	Master Status	R	---
00000100 (04H)		R/W	
00000101 (05H)	Per Channel Transmit signaling	R/W	CSTi
00000110 (06H)	Per Channel Transmit signaling	R/W	CSTi
00000111 (07H)	Per Time Slot Control		---
00001000 (08H)	Per Time Slot Control	R/W	---
00001001 (09H)	Per Channel Receive signaling	R/W	CSTo
00001010 (0AH)	Per Channel Receive signaling	R/W	CSTo
00001011 (0BH)	HDLC0 Control and Status	R/W	--
00001011 (0CH)	HDLC1 Control and Status	R/W	--
00001011 (0DH)	HDLC2 Control and Status	R/W	--
00001011 (0EH)	Tx National Bit Buffer	R/W	--
00001011 (0FH)	Rx National Bit Buffer	R	--

Table 13 - Page Summary

Please note that for microprocessors with read/write cycles less than 200 ns, a wait state or a dummy operation (for C programming) between two successive read/write operations to the HDLC FIFO is required.

Table 13 associates the MT9076 control and status pages with access and page descriptions.

4.3 Identification Code

The MT9076 shall be identified by the code 01111000, read from the identification code status register (page 03H, address 1FH).

4.3.1 ST-BUS Streams

In T1 mode, there is one control and one status ST-BUS stream that can be used to program / access channel associated signaling nibbles. CSTo contains the received channel associated signaling bits, and for those channels whose Per Time Slot Control word bit 1 “RPSIG” is set low, CSTi is used to control the transmit channel associated signaling. The DSTi and DSTo streams contain the transmit and receive voice and digital data. Only 24 of the 32 ST-BUS channels are used for each of DSTi, DSTo, CSTi and CSTo. In each case individual channel mapping is as illustrated in Table 6, “ST-BUS vs. DS1 to Channel Relationship(T1),” on page 30.

In E1 mode, ST-BUS streams can also be used to access channel associated signaling nibbles. CSTo contains the received channel associated signaling bits (e.g., ITU-T R1 and R2 signaling), and for those channels whose Per Time Slot Control word bit 1 “RPSIG” is set low, CSTi is used to control the transmit channel associated signaling. The DSTi and DSTo streams contain the transmit and receive voice and digital data.

Only 30 of the 32 ST-BUS channels are used for each of DSTi, DSTo, CSTi and CSTo. In each case individual channel mapping is as illustrated in Table 10 Time slot to Channel Relationship.

5.0 Reset Operation (Initialization)

The MT9076 can be reset using the hardware $\overline{\text{RESET}}$ pin (pin 11 in PLCC, pin 64 in LQFP) or the software reset bit RST (page 1H, address 1AH). When the device emerges from its reset state it will begin to function with the default settings described in Table 14 (T1) Table 15 (E1). All control registers are set to 00H. A reset operation takes 1 full frame (125 us) to complete.

Function	Status
Mode	D4
Loopbacks	Deactivated
SLC-96	Deactivated
Zero Coding	Deactivated
Line Codes	Deactivated
Data Link signaling	Serial Mode CAS Registers
AB/ABCD Bit Debounce	Deactivated
Interrupts	masked
Error Insertion	Deactivated
HDLCs	Deactivated
Counters	Cleared
Transmit Data	All Ones

Table 14 - Reset Status(T1)

Function	Status
Mode	Termination
Loopbacks	Deactivated
Transmit FAS	C_n 0011011
Transmit non-FAS	$1/S_n$ 1111111
Transmit MFAS (CAS)	00001111
Data Link	Deactivated
CRC Interworking	Activated
signaling	CAS Registers
ABCD Bit Debounce	Deactivated
Interrupts	Masked
RxMF Output	signaling Multiframe
Error Insertion	Deactivated
HDLCs	Deactivated
Counters	Cleared
Transmit Data	All Ones

Table 15 - Reset Status (E1)

6.0 Transmit Data All Ones (TxAO) Operation

The TxAO (Transmit all ones) pin allows the PRI interface to transmit an all ones signal under hardware control.

7.0 Data Link Operation

7.1 Data Link Operation in E1 Mode

In E1 mode, MT9076 has a user defined 4, 8, 12, 16 or 20 kbit/s data link for transport of maintenance and performance monitoring information across the PCM 30 link. This channel functions using the S_a bits ($S_{a4} \sim S_{a8}$) of the PCM 30 timeslot zero non-frame alignment signal (NFAS). Since the NFAS is transmitted every other frame - a periodicity of 250 microseconds - the aggregate bit rate is a multiple of 4 kb/s. As there are five S_a bits independently available for this data link, the bit rate will be 4, 8, 12, 16 or 20 kb/s, depending on the bits selected for the Data Link (DL).

The S_a bits used for the DL are selected by setting the appropriate bits, $S_{a4} \sim S_{a8}$, to one in the Data Link Select Word (page 01H, address 17H, bits 4-0). Access to the DL is provided by pins TxDLCLK, TxDL, RxDLCLK and RxDL, which allow easy interfacing to an external controller.

Data to be transmit onto the line in the S_a bit position is clocked in from the TxDL pin (pin 65 in PLCC, pin 47 in LQFP) with the clock TxDLCLK (pin 64 in PLCC, pin 46 pin LQFP). Although the aggregate clock rate equals the bit rate, it has a nominal pulse width of 244 ns, and it clocks in the TxDL as if it were a 2.048 Mb/s data stream. The clock can only be active during bit times 4 to 0 of the STBUS frame. The TxDL input signal is clocked into the MT9076 by the rising edge of TxDLCLK. If bits are selected to be a part of the DL, all other programmed functions for those S_a bit positions are overridden.

The RxDLCLK signal (pin 39 - PLCC, pin 14 - LQFP) is derived from the receive extracted clock and is aligned with the receive data link output RxDL. The HDB3 decoded receive data, at 2.048 Mbit/s, is clocked out of the device on pin RxDL (pin 40 in PLCC, pin 15 in LQFP). In order to facilitate the attachment of this data stream to a Data Link controller, the clock signal RxDLCLK consists of positive pulses, of nominal width of 244 ns, during the S_a bit cell times that are selected for the data link. This selection is made by programming address 17H of master control page 01H. No DL data will be lost or repeated when a receive frame slip occurs. See AC Electrical Characteristics for timing requirements.

7.2 Data Link Operation in T1 Mode

SLC-96 and ESF protocol allow for carrier messages to be embedded in the overhead bit position. The MT9076 provides 3 separate means of controlling these data links. See Data Link Control Word - address 12H, page 1H.

- The data links (transmit and receive) may be sourced (sunk) from an external controller using dedicated pins on the MT9076 in T1 mode (enabled by setting the bit 7 - EDL of the Data link Control Word).
- Bit Oriented Messages may be transmit and received via a dedicated TxBOM register (page 1H, address 13H) and a RxBOM (page 3H, address 15H). Transmission is enabled by setting bit 6 - BIOMEn in the Data link Control Word. Bit - oriented messages may be periodically interrupted (up to once per second) for a duration of up to 100 milliseconds. This is to accommodate bursts of message - oriented protocols. See Table 16 for message structure.

Octet #	8	7	6	5	4	3	2	1	Content
1	F	L	A	G					01111110
2	S	A	P	I		C / R		EA	00111000 or 00111010
3	T	E	I					EA	00000001
4	C	O	N	T	R	O	L		00000011
5	G3	LV	G4	U1	U2	G5	SL	G6	to
6	FE	SE	LB	G1	R	G2	Nm	NI	to
7	G3	LV	G4	U1	U2	G5	SL	G6	to-1
8	FE	SE	LB	G1	R	G2	Nm	NI	to-1
9	G3	LV	G4	U1	U2	G5	SL	G6	to-2
10	FE	SE	LB	G1	R	G2	Nm	NI	to-2
11	G3	LV	G4	U1	U2	G5	SL	G6	to-3
12	FE	SE	LB	G1	R	G2	Nm	NI	to-3
13	F C S								VARIABLE
14									

Table 16 - Message Oriented Performance Report Structure (T1.403 and T1.408)

Note:	<u>ADDRESS</u>	<u>INTERPRETATION</u>
	00111000	SAPI = 14, C/R = 0 (CI) EA = 0
	00111010	SAPI = 14, C/R = 1(Carrier) EA = 0
	00000001	TEI = 0, EA =1
	<u>CONTROL</u>	<u>INTERPRETATION</u>
	00000011	Unacknowledged Information Transfer
	<u>ONE SECOND REPORT</u>	<u>INTERPRETATION</u>
	G1 = 1	CRC Error Event =1
	G2 =1	1 < CRC Error Event < 5
	G3 =1	5 < CRC Error Event < 10
	G4 =1	10 < CRC Error Event < 100
	G5 =1	100 < CRC Error Event < 319
	G6 =1	CRC Error Event > 320
	SE=1	Severely - Errored Framing Event >=1
	FE=1	Frame Synchronization Bit Error Event >=1
	LV=1	Line code Violation Event >=1
	SL=1	Slip Event >=1
	LB=1	Payload Loopback Activated
	U1,U2=0	Under Study for sync.
	R=0	Reserved - set to 0
	NmNI=00,01,10,11	One Second Module 4 counter
	<u>FCS</u>	<u>INTERPRETATION</u>
	VARIABLE	CRC16 Frame Check Sequence

7.2.1 External Data Link

In T1 mode, MT9076 has two pairs of pins (TxDL and TxDLCLK, RxDL and RxDLCLK) dedicated to transmitting and receiving bits in the selected overhead bit positions. Pins TxDLCLK and RxDLCLK are clock outputs available for clocking data into the MT9076 (for transmit) or external device (for receive information). Each clock operates at 4 Khz. In the SLC-96 mode the optional serial data link is multiplexed into the Fs bit position. In the ESF mode, the serial data link is multiplexed into odd frames, i.e., the FDL bit positions.

7.2.2 Bit - Oriented Messaging

In T1 mode, MT9076 Bit oriented messaging may be selected by setting bit 6 (BIOMEn) in the Data Link Control Word (page 1H, address 12H). The transmit data link will contain the repeating serial data stream 11111110xxxxx0 where the byte 0xxxxx0 originates from the user programmed register "Transmit Bit Oriented Message" - page 1H address 13H. The receive BIOM register "Receive Bit Oriented Message" - page 3H, address 15H, will contain the last received valid message (the 0xxxxx0 portion of the incoming serial bit stream). To prevent spurious inputs from creating false messages, a new message must be present in 7 of the last 10 appropriate byte positions before being loaded into the receive BIOM register. When a new message has been received, a maskable interrupt (maskable by setting bit 1 low in Interrupt Mask Word Three - page 1H, address 1EH) may occur.

8.0 Floating HDLC Channels

MT9076 has three embedded HDLC controllers (HDLC0, HDLC1, HDLC2) each of which includes the following features:

- Independent transmit and receive FIFO's;
- Receive FIFO maskable interrupts for nearly full (programmable interrupt levels) and overflow conditions;
- Transmit FIFO maskable interrupts for nearly empty (programmable interrupt levels) and underflow conditions;
- Maskable interrupts for transmit end-of-packet and receive end-of-packet;

- Maskable interrupts for receive bad-frame (includes frame abort);
- Transmit end-of-packet and frame-abort functions.

Each controller may be attached to any of the active 64 Kkb/s channels (24 in the case of T1, 31 in the case of E1). HDLC0 may also be attached to the FDL in a T1 ESF link by connecting it to phantom channel 31 when programming the HDLC Select Word. If HDLC0 is attached to channel 0 in E1 mode, only the activated Sa bits (as per the Multiframe and Data Selection Word) will be transmit and received by the controller.

8.1 Channel Assignment

In T1 mode, any DS1 channel can be connected to either of HDLC0,1 or 2, operating at 56 or 64 Kb/s. Setting control bit H1R64 (address 12 H on page 01H) high selects 64 Kb/s operation for all HDLCs. Setting this bit low selects 56 Kb/s for all HDLC. Interrupts from any of the HDLCs are masked when they are disconnected.

In E1 mode, all PCM-30 channels except channel 0 can be connected to either of HDLC0,1 or 2. HDLC1 and HDLC2 operate at 64 Kb/s. HDLC0 operates at 64 kb/s when connected to any of channels 1 to 31. When connected to channel 0 HDLC0 operates at 4, 8, 12, 16 or 20 Kb/s depending on the number of activated Sa bits.

HDLCs can be activated by programming the HDLC Select Words (page 02H, addresses 19H, 1AH and 1BH for HDLC0, HDLC1 and HDLC2 respectively).

8.2 HDLC Description

The HDLC handles the bit oriented packetized data transmission as per X.25 level two protocol defined by CCITT. It provides flag and abort sequence generation and detection, zero insertion and deletion, and Frame Check Sequence (FCS) generation and detection. A single byte, dual byte and all call address in the received frame can be recognized. Access to the receive FCS and inhibiting of transmit FCS for terminal adaptation are also provided. Each HDLC controller has a 128 byte deep FIFO associated with it. The status and interrupt flags are programmable for FIFO depths that can vary from 16 to 128 bytes in steps of 16 bytes. These and other features are enabled through the HDLC control registers on page 0BH and 0CH.

8.2.1 HDLC Frame Structure

In T1 mode or E1 mode, a valid HDLC frame begins with an opening flag, contains at least 16 bits of address and control or information, and ends with a 16 bit FCS followed by a closing flag. Data formatted in this manner is also referred to as a “packet”. Refer to Table 17: HDLC Frame Format

Flag (7E)	Data Field	FCS	Flag (7E)
One Byte 01111110	n Bytes $n \geq 2$	Two Bytes	One Byte 01111110

Table 17 - HDLC Frame Format

All HDLC frames start and end with a unique flag sequence “01111110”. The transmitter generates these flags and appends them to the packet to be transmitted. The receiver searches the incoming data stream for the flags on a bit-by-bit basis to establish frame synchronization.

The data field consists of an address field, control field and information field. The address field consists of one or two bytes directly following the opening flag. The control field consists of one byte directly following the address field. The information field immediately follows the control field and consists of N bytes of data. The HDLC does not distinguish between the control and information fields and a packet does not need to contain an information field to be valid.

The FCS field, which precedes the closing flag, consists of two bytes. A cyclic redundancy check utilizing the CRC-CCITT standard generator polynomial “ $X^{16}+X^{12}+X^5+1$ ” produces the 16-bit FCS. In the transmitter the FCS is

calculated on all bits of the address and data field. The complement of the FCS is transmitted, most significant bit first, in the FCS field. The receiver calculates the FCS on the incoming packet address, data and FCS field and compares the result to "F0B8". If no transmission errors are detected and the packet between the flags is at least 32 bits in length then the address and data are entered into the receive FIFO minus the FCS which is discarded.

8.2.2 Data Transparency (Zero Insertion/Deletion)

Transparency ensures that the contents of a data packet do not imitate a flag, go-ahead, frame abort or idle channel. The contents of a transmitted frame, between the flags, is examined on a bit-by-bit basis and a 0 bit is inserted after all sequences of 5 contiguous 1 bits (including the last five bits of the FCS). Upon receiving five contiguous 1s within a frame the receiver deletes the following 0 bit.

8.2.3 Invalid Frames

A frame is invalid if one of the following four conditions exists (Inserted zeros are not part of a valid count):

- If the FCS pattern generated from the received data does not match the "F0B8" pattern then the last data byte of the packet is written to the received FIFO with a 'bad packet' indication.
- A short frame exists if there are less than 25 bits between the flags. Short frames are ignored by the receiver and nothing is written to the receive FIFO.
- Packets which are at least 25 bits in length but less than 32 bits between the flags are also invalid. In this case the data is written to the FIFO but the last byte is tagged with a "bad packet" indication.
- If a frame abort sequence is detected the packet is invalid. Some or all of the current packet will reside in the receive FIFO, assuming the packet length before the abort sequence was at least 26 bits long.

8.2.4 Frame Abort

The transmitter will abort a current packet by substituting a zero followed by seven contiguous 1s in place of the normal packet. The receiver will abort upon reception of seven contiguous 1s occurring between the flags of a packet which contains at least 26 bits.

Note that should the last received byte before the frame abort end with contiguous 1s, these are included in the seven 1s required for a receiver abort. This means that the location of the abort sequence in the receiver may occur before the location of the abort sequence in the originally transmitted packet. If this happens then the last data written to the receive FIFO will not correspond exactly with the last byte sent before the frame abort.

8.2.5 Interframe Time Fill and Link Channel States

When the HDLC transmitter is not sending packets it will wait in one of two states

- Interframe Time Fill state: This is a continuous series of flags occurring between frames indicating that the channel is active but that no data is being sent.
- Idle state: An idle Channel occurs when at least 15 contiguous 1s are transmitted or received.
- In both states the transmitter will exit the wait state when data is loaded into the transmitter FIFO.

8.2.6 Go-Ahead

A go ahead is defined as the pattern "01111110" (contiguous 7Fs) and is the occurrence of a frame abort sequence followed by a zero, outside of the boundaries of a normal packet. Being able to distinguish a proper (in packet) frame abort sequence from one occurring outside of a packet allows a higher level of signaling protocol which is not part of the HDLC specifications.

8.3 HDLC Functional Description

The HDLC transceiver can be reset by either the power reset input signal or by the HRST Control bit in the test control register (software reset). When reset, the HDLC Control Registers are cleared, resulting in the transmitter and receiver being disabled. The Receiver and Transmitter can be enabled independent of one another through Control Register 1. The transceiver input and output are enabled when the enable control bits in Control Register 1 are set. Transmit to receive loopback as well as a receive to transmit loopback are also supported. Transmit and receive bit rates and enables can operate independently. In MT9076 the transceiver can operate at a continuous rate independent of RXcen and TXcen (free run mode) by setting the Frun bit of Control Register 1.

Received packets from the serial interface are sectioned into bytes by an HDLC receiver that detects flags, checks for go-ahead signals, removes inserted zeros, performs a cyclical redundancy check (CRC) on incoming data, and monitors the address if required. Packet reception begins upon detection of an opening flag. The resulting bytes are concatenated with two status bits (RQ9, RQ8) and placed in a receiver first-in-first-out (Rx FIFO); a buffer register that generates status and interrupts for microprocessor read control.

In conjunction with the control circuitry, the microprocessor writes data bytes into a Tx buffer register (Tx FIFO) that generates status and interrupts. Packet transmission begins when the microprocessor writes a byte to the Tx FIFO. Two status bits are added to the Tx FIFO for transmitter control of frame aborts (FA) and end of packet (EOP) flags. Packets have flags appended, zeros inserted, and a CRC, also referred to as frame checking sequence (FCS), added automatically during serial transmission. When the Tx FIFO is empty and finished sending a packet, Interframe Time Fill bytes (continuous flags (7E hex)), or Mark Idle (continuous ones) are transmitted to indicate that the channel is idle.

8.3.1 HDLC Transmitter

Following initialization and enabling, the transmitter is in the Idle Channel state (Mark Idle), continuously sending ones. Interframe Time Fill state (Flag Idle) is selected by setting the Mark idle bit in Control Register 1 high¹. The Transmitter remains in either of these two states until data is written to the Tx FIFO. Control Register 1 bits EOP (end of packet) and FA (Frame Abort) are set as status bits before the microprocessor loads 8 bits of data into the 10 bit wide FIFO (8 bits data and 2 bits status). To change the tag bits being loaded in the FIFO, Control Register 1 must be written to before writing to the FIFO. However, EOP and FA are reset after writing to the TX FIFO. The Transmit Byte Count Registers may also be used to tag an end of packet. The total packet size may be programmed to be up to 65,535 bytes. For a packet length of 1 to 255 bytes it is only necessary to write the packet size into the Lower Transmit Byte Count Register. For a packet length of 256 to 65,535 bytes it is necessary to write the 16 bit binary count into the Extended Transmit Byte Count Register (MSByte) and the Lower Transmit Byte Count Register (LSByte). Note that the order of writing the upper byte before the lower byte must be observed even when the lower byte is all zero. Internal registers are loaded with the number of bytes in the packet and decremented after every write to the Tx FIFO. When a count of one is reached, the next byte written to the FIFO is tagged as an end of packet. The register may be made to cycle through the same count if the packets are of the same length by setting Control Register 2 bit Cycle.

If the transmitter is in the Idle Channel state when data is written to the Tx FIFO, then an opening flag is sent and data from Tx FIFO follows. Otherwise, data bytes are transmitted as soon as the current flag byte has been sent. Tx FIFO data bytes are continuously transmitted until either the FIFO is empty or an EOP or FA status bit is read by the transmitter. After the last bit of the EOP byte has been transmitted, a 16-bit FCS is sent followed by a closing flag. When multiple packets of data are loaded into Tx FIFO, only one flag is sent between packets.

1. If the MT9076 HDLC transmitter is set up in the Mark-Idle state (YF2 MI is 1) then it will occasionally (less than 1% of the time) fail to transmit the opening flag when it is changed from the disabled state to the enabled state (YF2 TXEN changed from 0 to 1). A missing opening flag will cause the packet to be lost at the receiving end.

This problem only affects the first packet transmitted after the HDLC transmitter is enabled. Subsequent packets are unaffected.

Frame aborts (the transmission of 7F hex), are transmitted by tagging a byte previously written to the Tx FIFO. When a byte has an FA tag, then an FA is sent instead of that tagged byte. That is, all bytes previous to but not including that byte are sent. After a Frame Abort, the transmitter returns to the Mark Idle or Interframe Time Fill state, depending on the state of the Mark idle control bit.

Tx FIFO underrun will occur if the FIFO empties and the last byte did not have either an EOP or FA tag. A frame abort sequence will be sent when an underrun occurs.

The following list is an example of the transmission of a three byte packet ('AA'03'77' hex) (Interframe time fill). TXcen can be enabled before or after this sequence.

- | | |
|---|--------------------------------|
| (a) Write '04'hex to Control Register 1 | -Mark idle bit set |
| (b) Write 'AA' hex to TX FIFO | -Data byte |
| (c) Write '03'hex to TX FIFO | -Data byte |
| (d) Write '34'hex to Control Register 1 | -TXEN; EOP; Mark idle bits set |
| (e) Write '77'hex to TX FIFO | -Final data byte |

The transmitter may be enabled independently of the receiver. This is done by setting the TXEN bit of the Control Register. Enabling happens immediately upon writing to the register. Disabling using TXen will occur after the completion of the transmission of the present packet; the contents of the FIFO are not cleared. Disabling will consist of stopping the transmitter clock. The Status and Interrupt Registers may still be read and the FIFO and Control Registers may be written to while the transmitter is disabled. The transmitted FCS may be inhibited using the Trci bit of Control Register 2. In this mode the opening flag followed by the data and closing flag is sent and zero insertion still included, but no CRC. That is, the FCS is injected by the microprocessor as part of the data field. This is used in V.120 terminal adaptation for synchronous protocol sensitive UI frames.

8.3.2 HDLC Receiver

After initialization and enabling, the receiver clocks in serial data, continuously checking for Go-aheads (0 1111 1110), flags (0111 1110), and Idle Channel states (at least fifteen ones). When a flag is detected, the receiver synchronizes itself to the serial stream of data bits, automatically calculating the FCS. If the data length between flags after zero removal is less than 25 bits, then the packet is ignored so no bytes are loaded into Rx FIFO. When the data length after zero removal is between 25 and 31 bits, a first byte and bad FCS code are loaded into the Rx FIFO (see definition of RQ8 and RQ9 below). For an error-free packet, the result in the CRC register should match the HEX pattern of 'F0B8' when a closing flag is detected.

If address recognition is required, the Receiver Address Recognition Registers are loaded with the desired address and the Adrec bit in the Control Register 1 is set high. Bit 0 of the Address Registers is used as an enable bit for that byte, thus allowing either or both of the first two bytes to be compared to the expected values. Bit 0 of the first byte of the address received (address extension bit) will be monitored to determine if a single or dual byte address is being received. If this bit is 0 then a two byte address is being received and then only the first six bits of the first address byte are compared. An all call condition is also monitored for the second address byte; and if received the first address byte is ignored (not compared with mask byte). If the address extension bit is a 1 then a single byte address is being received. In this case, an all call condition is monitored for in the first byte as well as the mask byte written to the comparison register and the second byte is ignored. Seven bits of address comparison can be realized on the first byte if this is a single byte address by setting the Seven bit of Control Register 2.

The following two Status Register bits (RQ8 and RQ9) are appended to each data byte as it is written to the Rx FIFO. They indicate that a good packet has been received (good FCS and no frame abort), or a bad packet with either incorrect FCS or frame abort. The Status and Interrupt Registers should be read before reading the Rx FIFO since status and interrupt information correspond to the byte at the output of the FIFO (i.e., the byte about to be read). The Status Register bits are encoded as follows:

<u>RQ9</u>	<u>RQ8</u>	<u>Byte status</u>
1	1	last byte (bad packet)
0	1	first byte
1	0	last byte (good packet)
0	0	packet byte

The end-of-packet-detect (EOPD) interrupt indicates that the last byte written to the Rx FIFO was an EOP byte (last byte in a packet). The end-of-packet-read (EopR) interrupt indicates that the byte about to be read from the Rx FIFO is an EOP byte (last byte in a packet). The Status Register should be read to see if the packet is good or bad before the byte is read.

A minimum size packet has an 8-bit address, an 8-bit control byte, and a 16-bit FCS pattern between the opening and closing flags (see Section 9.3.2). Thus, the absence of a data transmission error and a frame length of at least 32 bits results in the receiver writing a valid packet code with the EOP byte into Rx FIFO. The last 16 bits before the closing flag are regarded as the FCS pattern and will not be transferred to the receiver FIFO. Only data bytes (Address, Control, Information) are loaded into the Rx FIFO.

In the case of an Rx FIFO overflow, no clocking occurs until a new opening flag is received. In other words, the remainder of the packet is not clocked into the FIFO. Also, the top byte of the FIFO will not be written over. If the FIFO is read before the reception of the next packet then reception of that packet will occur. If two beginning of packet conditions (RQ9=0;RQ8=1) are seen in the FIFO, without an intermediate EOP status, then overflow occurred for the first packet.

The receiver may be enabled independently of the transmitter. This is done by setting the RXEN bit of Control Register 1. Enabling happens immediately upon writing to the register. Disabling using RXEN will occur after the present packet has been completely loaded into the FIFO. Disabling can occur during a packet if no bytes have been written to the FIFO yet. Disabling will consist of disabling the internal receive clock. The FIFO, Status, and Interrupt Registers may still be read while the receiver is disabled. Note that the receiver requires a flag before processing a frame, thus if the receiver is enabled in the middle of an incoming packet it will ignore that packet and wait for the next complete one.

The receive CRC can be monitored in the Rx CRC Registers. These registers contain the actual CRC sent by the other transmitter in its original form; that is, MSB first and bits inverted. These registers are updated by each end of packet (closing flag) received and therefore should be read when an end of packet is received so that the next packet does not overwrite the registers.

9.0 Slip Buffers

9.1 Slip Buffer in T1 Mode

In T1 mode, MT9076 contains two slip buffers, one on the transmit side, and one on the receive side. Both sides may perform a controlled slip. The mechanisms that govern the slip function are a function of backplane timing and the mapping between the ST-BUS channels and the DS1 channels. The slip mechanisms are different for the transmit and receive slip buffers. The extracted 1.544 MHz clock (Exclk) and the internally generated transmit 1.544 MHz clock are distinct. Slips on the transmit side are independent from slips on the receive side. In IMA mode neither the transmit nor receive slip buffer is activated.

The transmit slip buffer has data written to it from the near end 2.048 Mb/s stream. The data is clocked out of the buffer using signals derived from the transmit 1.544 MHz clock. The transmit 1.544 MHz clock is always phase locked to the DSTi 2.048 Mb/s stream. If the system 4.096 MHz clock ($\overline{C4b}$) is internally generated (pin BS/LS low), then it is hard locked to the 1.544 MHz clock. No phase drift or wander can exist between the two signals - therefore no slips will occur. The delay through the transmit elastic buffer is then fixed, and is a function of the relative mapping between the DSTi channels and the DS1 timeslots. These delays vary with the position of the channel in the frame. For example, DS1 timeslot 1 sits in the elastic buffer for approximately 1 usec and DS1 timeslot 24 sits in the elastic buffer for approximately 32 usec.

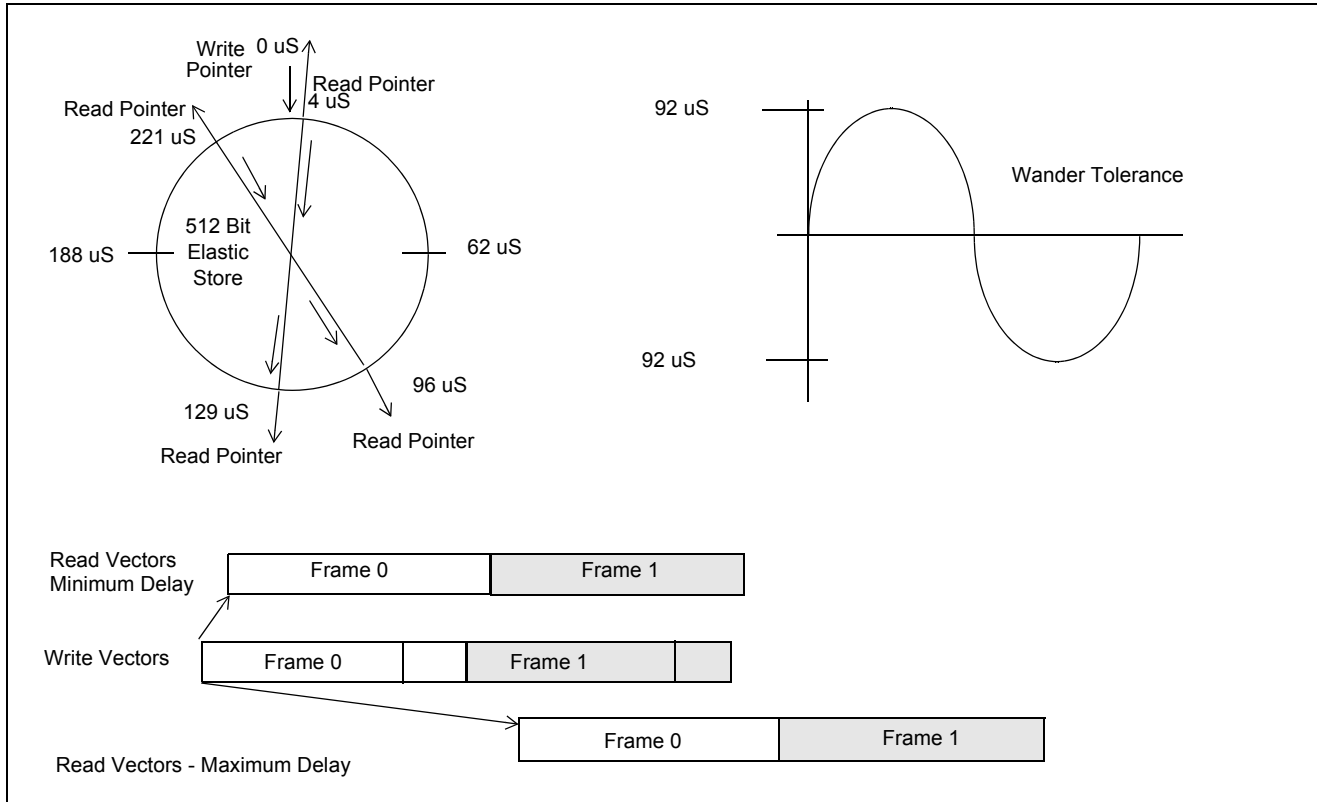

Figure 11 - Read and Write Pointers in the Transmit Slip Buffers

If the system 4.096 MHz clock ($\overline{C4b}$) is externally generated (pin BS/LS high), the transmit 1.544 MHz clock is phase locked to it, but the PLL is designed to filter jitter present in the $\overline{C4b}$ clock. As a result phase drift will result between the two signals. The delay through the transmit elastic buffer will vary in accordance with the input clock drift, as well as being a function of the relative mapping between the DSTi channels and the DS1 timeslots. If the read pointers approach the write pointers (to within approximately 1 usec) or the delay through the transmit buffer exceeds 218 usecs a controlled slip will occur. The contents of a single frame of DS1 data will be skipped or repeated; a maskable interrupt (masked by setting bit 1 - TxSLPI high in Interrupt Mask Word Zero - page 1H, address 1bH) will be generated, and the status bit TSLIP (page 3H, address 17H) of MSB Transmit Slip Buffer register will toggle. The direction of the slip is indicated by bit 6 of the same register (TSLPD). The relative phase delay between the system frame boundary and the transmit elastic frame read boundary is measured every frame and reported in the Transmit Slip Buffer Delay register- (page 3H, address 17H). In addition the relative offset between these frame boundaries may be programmed by writing to this register. Every write to Transmit Elastic Buffer Set Delay Word resets the transmit elastic frame count bit TxSBMSB (address 17H, page 3H). After a write the delay through the slip buffer is less than 1 frame in duration. Each write operation will result in a disturbance of the transmit DS1 frame boundary, causing the far end to go out of sync. Writing BC (hex) into the TxSBDLY register maximizes the wander tolerance before a controlled slip occurs. Under normal operation no slips should occur in

the transmit path. Slips will only occur if the input $\overline{C4b}$ clock has excess wander, or the Transmit Elastic Buffer Set Delay Word register is initialized too close to the slip pointers after system initialization.

The two frame receive elastic buffer is attached between the 1.544 Mbit/s DS1 receive side and the 2.048 Mbit/s ST-BUS side of the MT9076. Besides performing rate conversion, this elastic buffer is configured as a slip buffer which absorbs wander and low frequency jitter in multi-trunk applications. The received DS1 data is clocked into the slip buffer with the Exclk clock and is clocked out of the slip buffer with the system $\overline{C4b}$ clock. The Exclk extracted clock is generated from, and is therefore phase-locked with, the receive DS1 data. In the case of Internal mode (pin BS/LS set low) operation, the Exclk clock may be phase-locked to the $\overline{C4b}$ clock by an internal phase locked loop (PLL). Therefore, in a single trunk system the receive data is in phase with the Exclk clock, the $\overline{C4b}$ clock is phase locked to the E1.5o clock, and the read and write positions of the slip buffer track each other.

In a multi-trunk slave or loop-timed system (i.e., PABX application) a single trunk will be chosen as a network synchronizer, which will function as described in the previous paragraph. The remaining trunks will use the system timing derived from the synchronizer to clock data out of their slip buffers. Even though the DS1 signals from the network are synchronous to each other, due to multiplexing, transmission impairments and route diversity, these signals may jitter or wander with respect to the synchronizing trunk signal. Therefore, the Exclk clocks of non-synchronized trunks may wander with respect to the Exclk clock of the synchronizer and the system bus. Network standards state that, within limits, trunk interfaces must be able to receive error-free data in the presence of jitter and wander (refer to network requirements for jitter and wander tolerance). The MT9076 will allow 92 usec (140 UI, DS1 unit intervals) of wander and low frequency jitter before a frame slip will occur.

When the $\overline{C4b}$ and the Exclk clocks are not phase-locked, the rate at which data is being written into the slip buffer from the DS1 side may differ from the rate at which it is being read out onto the ST-BUS. If this situation persists, the delay limits stated in the previous paragraph will be violated and the slip buffer will perform a controlled frame slip. That is, the buffer pointers will be automatically adjusted so that a full DS1 frame is either repeated or lost. All frame slips occur on frame boundaries.

The minimum delay through the receive slip buffer is approximately 1 usec and the maximum delay is approximately 249 uS. Figure 12 illustrates the relationship between the read and write pointers of the receive slip buffer (contiguous time slot mapping). Measuring clockwise from the write pointer, if the read page pointer comes within 8 usec of the write page pointer a frame slip will occur, which will put the read page pointer 157 usec from the write page pointer. Conversely, if the read page pointer moves more than 249 usec from the write page pointer, a slip will occur, which will put the read page pointer 124 usec from the write page pointer. This provides a worst case hysteresis of 92 usec peak = 142 U.I.

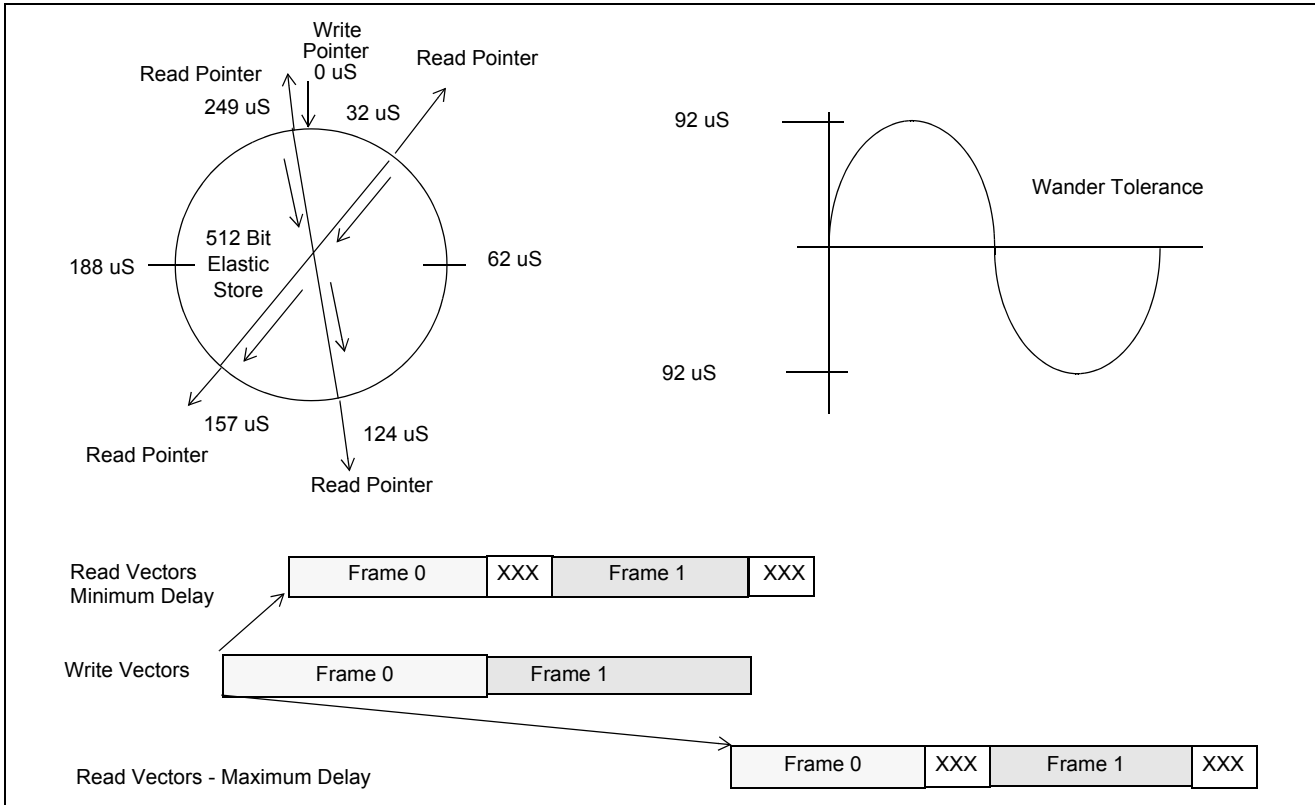

Figure 12 - Read and Write Pointers in the Receive Slip Buffers

The RSLIP and RSLPD status bits (page 3H, address 13H, bits 7 and 6 respectively) give indication of a receive slip occurrence and direction. A maskable interrupt RxSLPI (page 1H, address 1BH, bit 0 - set high to mask) is also provided. RSLIP changes state in the event of a slip. If RSLPD=0, the slip buffer has overflowed and a frame was lost; if RSLPD=1, a underflow condition occurred and a frame was repeated.

9.2 Slip Buffer in E1 Mode

In E1 mode, in addition to the elastic buffer in the jitter attenuator(JA), another elastic buffer (two frames deep) is present, attached between the receive side and the ST-BUS side of the MT9076. This elastic buffer is configured as a slip buffer which absorbs wander and low frequency jitter in multi-trunk applications. The received PCM 30 data is clocked into the slip buffer with the Exclk clock and is clocked out of the slip buffer with the C4b clock. The Exclk extracted clock is generated from, and is therefore phase-locked with, the receive PCM 30 data. In normal operation, the C4b clock will be phase-locked to the Exclk clock by a phase locked loop (PLL). Therefore, in a single trunk system the receive data is in phase with the Exclk clock, the C4b clock is phase-locked to the Exclk clock, and the read and write positions of the slip buffer will remain fixed with respect to each other.

In a multi-trunk slave or loop-timed system (i.e., PABX application) a single trunk will be chosen as a network synchronizer, which will function as described in the previous paragraph. The remaining trunks will use the system timing derived from the synchronizer to clock data out of their slip buffers. Even though the PCM 30 signals from the network are synchronous to each other, due to multiplexing, transmission impairments and route diversity, these signals may jitter or wander with respect to the synchronizing trunk signal. Therefore, the

Exclk clocks of non-synchronizer trunks may wander with respect to the Exclk clock of the synchronizer and the system bus.

Network standards state that, within limits, trunk interfaces must be able to receive error-free data in the presence of jitter and wander (refer to network requirements for jitter and wander tolerance). The MT9076 will allow a maximum of 26 channels (208 UI, unit intervals) of wander and low frequency jitter before a frame slip will occur.

The minimum delay through the receive slip buffer is approximately two channels and the maximum delay is approximately 60 channels (see Figure 13).

When the $\overline{C4b}$ and the Exclk clocks are not phase-locked, the rate at which data is being written into the slip buffer from the PCM 30 side may differ from the rate at which it is being read out onto the ST-BUS. If this situation persists, the delay limits stated in the previous paragraph will be violated and the slip buffer will perform a controlled frame slip. That is, the buffer pointers will be automatically adjusted so that a full PCM 30 frame is either repeated or lost. All frame slips occur on PCM 30 frame boundaries.

Two status bits, RSLIP and RSLPD (page03H, address13H) give indication of a slip occurrence and direction. RSLIP changes state in the event of a slip. If RSLPD=0, the slip buffer has overflowed and a frame was lost; if RSLPD=1, a underflow condition occurred and a frame was repeated. A maskable interrupt SLPI (page 01H, address 1BH) is also provided.

Figure 13 illustrates the relationship between the read and write pointers of the receive slip buffer. Measuring clockwise from the write pointer, if the read pointer comes within two channels of the write pointer a frame slip will occur, which will put the read pointer 34 channels from the write pointer. Conversely, if the read pointer moves more than 60 channels from the write pointer, a slip will occur, which will put the read pointer 28 channels from the write pointer. This provides a worst case hysteresis of 13 channels peak (26 channels peak-to-peak) or a wander tolerance of 208 UI.

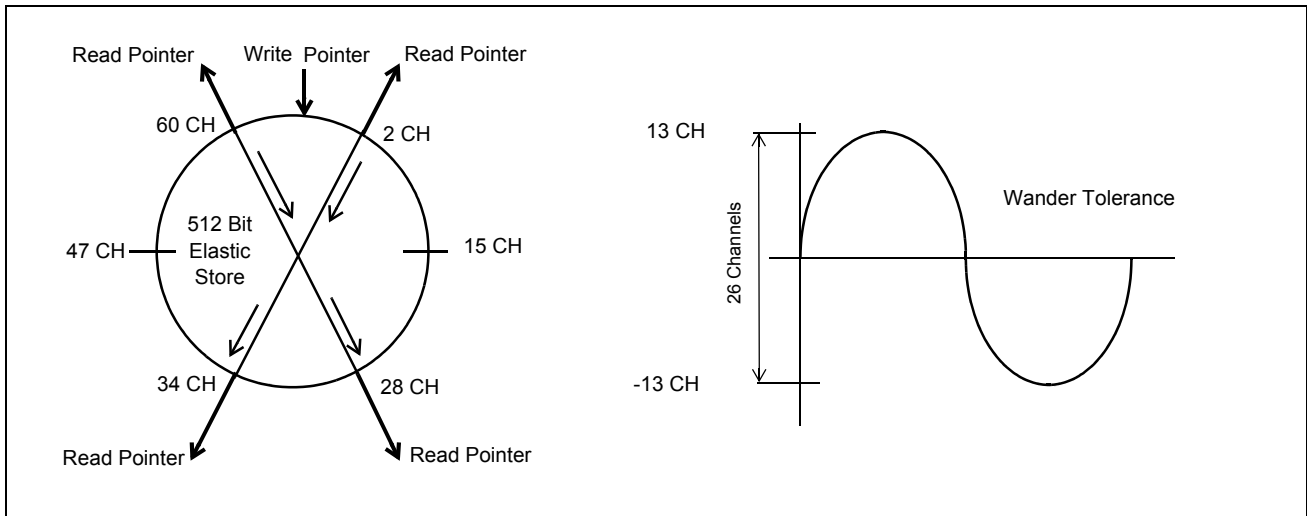

Figure 13 - Read and Write Pointers in the Slip Buffers

10.0 Framing Algorithm

10.1 Frame Alignment in T1 Mode

In T1 mode, MT9076 will synchronize to DS1 lines formatted with either the D4 or ESF protocol. In either mode the framer maintains a running 3 bit history of received data for each of the candidate bit positions. Candidate bit positions whose incoming patterns fail to match the predicted pattern (based on the 3 bit history) are winnowed out. If, after a 10 bit history has been examined, only one candidate bit position remains within the framing bit period, the receive side timebase is forced to align to that bit position. If no candidates remain after a 10 bit history, the process is re-initiated. If multiple candidates exist after a 24 bit history timeout period, the framer forces the receive side

timebase to synchronize to the next incoming valid candidate bit position. In the event of a reframe, the framer starts searching at the next bit position over. This prevents persistent locking to a mimic as the controller may initiate a software controlled reframe in the event of locking to a mimic.

Under software control the framing criteria may be tuned (see Framing Mode Select Register, page 1H, address 10H). Selecting D4 framing invites a further decision whether or not to include a cross check of Fs bits along with the Ft bits. If Fs bits are checked (by setting control bit CXC high - bit 5 of the Framing Mode Select Word, page 1H, address 10H), multiframe alignment is forced at the same time as terminal frame alignment. If only Ft bits are checked, multiframe alignment is forced separately, upon detection of the Fs bit history of 00111 (for normal D4 trunks) or 000111000111 (for SLC-96 trunks). For D4 trunks, a reframe on the multiframe alignment may be forced at any time without affecting terminal frame alignment.

In ESF mode, the circuit will optionally confirm the CRC-6 bits before forcing a new frame alignment. This is programmed by setting control bit CXC high (bit 5 of the Framing Mode Select Word, page 1H, address 10H). A CRC-6 confirmation adds a minimum of 6 milliseconds to the reframe time. If no CRC-6 match is found after 16 attempts, the framer moves to the next valid candidate bit position (assuming other bit positions contain a match to the framing pattern) or re-initiates the whole framing procedure (assuming no bit positions have been found to match the framing pattern).

The framing circuit is off - line. During a reframe, the rest of the circuit operates synchronous with the last frame alignment. Until such time as a new frame alignment is achieved, the signaling bits are frozen in their states at the time that frame alignment was lost, and error counting for Ft, Fs, ESF framing pattern or CRC-6 bits is suspended.

10.2 Frame Alignment in E1 Mode

In E1 mode, MT9076 contains three distinct framing algorithms: basic frame alignment, signaling multiframe alignment and CRC-4 multiframe alignment. Figure 14 is a state diagram that illustrates these algorithms and how they interact.

After power-up, the basic frame alignment framer will search for a frame alignment signal (FAS) in the PCM 30 receive bit stream. Once the FAS is detected, the corresponding bit 2 of the non-frame alignment signal (NFAS) is checked. If bit 2 of the NFAS is zero a new search for basic frame alignment is initiated. If bit 2 of the NFAS is one and the next FAS is correct, the algorithm declares that basic frame synchronization has been found (i.e., page 03H, address 10H, bit 7, SYNC is zero).

Once basic frame alignment is acquired the signaling and CRC-4 multiframe searches will be initiated. The signaling multiframe algorithm will align to the first multiframe alignment signal pattern (MFAS = 0000) it receives in the most significant nibble of channel 16 (page 3, address 10H, bit 6, MFSYNC = 0). signaling multiframing will be lost when two consecutive multiframes are received in error.

The CRC-4 multiframe alignment signal is a 001011 bit sequence that appears in PCM 30 bit position one of the NFAS in frames 1, 3, 5, 7, 9 and 11 (see Table 11). In order to achieve CRC-4 synchronization two consecutive CRC-4 multiframe alignment signals must be received without error (page 03H, address 10H CRCSYN = 0).

The E1 framing algorithm supports automatic interworking of interfaces with and without CRC-4 processing capabilities. That is, if an interface with CRC-4 capability, achieves valid basic frame alignment, but does not achieve CRC-4 multiframe alignment by the end of a predefined period, the distant end is considered to be a non-CRC-4 interface. When the distant end is a non-CRC-4 interface, the near end automatically suspends receive CRC-4 functions, continues to transmit CRC-4 data to the distant end with its E-bits set to zero, and provides a status indication. Naturally, if the distant end initially achieves CRC-4 synchronization, CRC-4 processing will be carried out by both ends. This feature is selected when control bit AUTC (page 01H, address 10H) is set to zero.

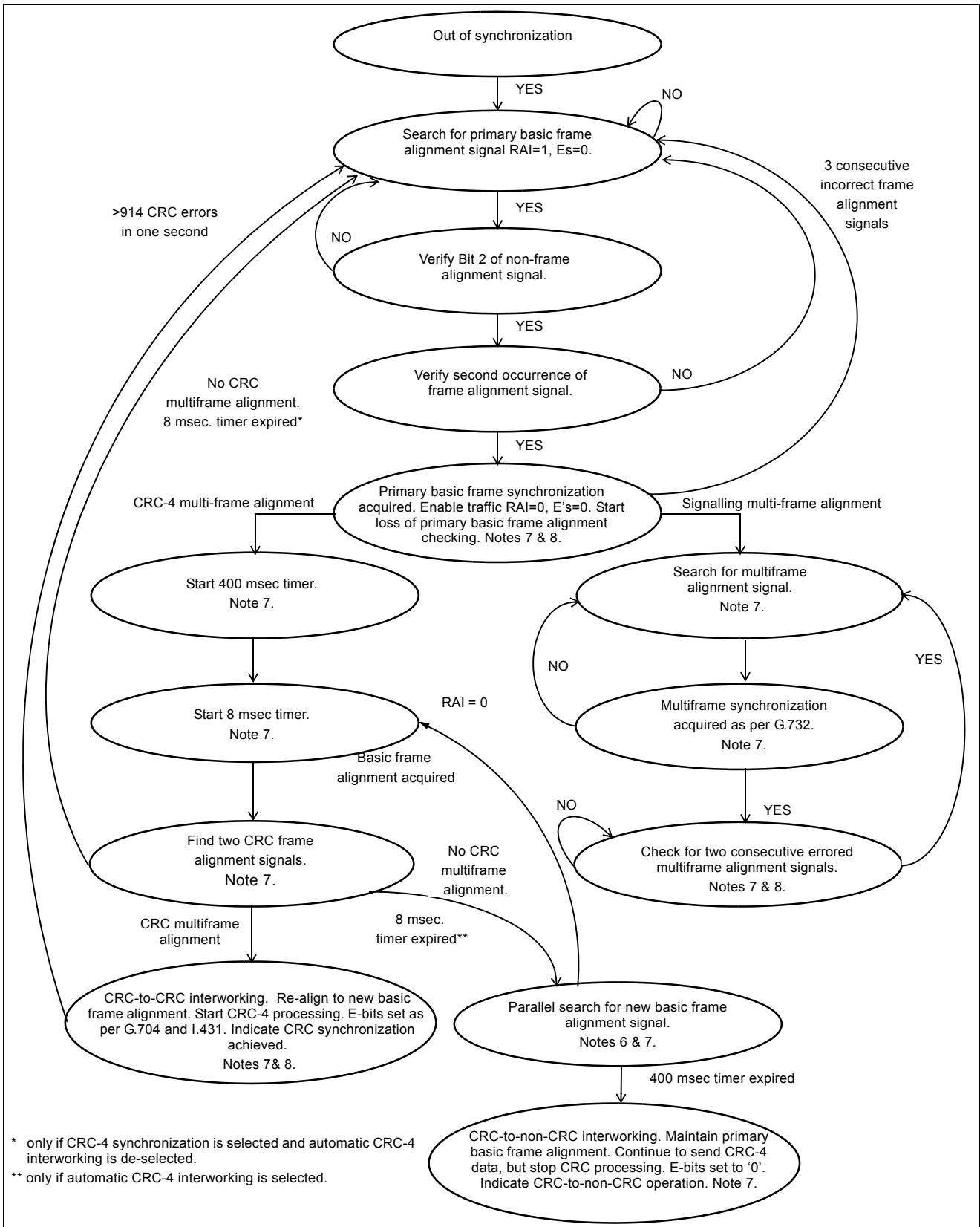

* only if CRC-4 synchronization is selected and automatic CRC-4 interworking is de-selected.
 ** only if automatic CRC-4 interworking is selected.

Figure 14 - Synchronization State Diagram

10.2.1 Notes for Synchronization State Diagram (Figure 14)

- 1) The basic frame alignment, signaling multiframe alignment, and CRC-4 multiframe alignment functions operate in parallel and are independent.
- 2) The receive channel associated signaling bits and signaling multiframe alignment bit will be frozen when multiframe alignment is lost.
- 3) Manual re-framing of the receive basic frame alignment and signaling multiframe alignment functions can be performed at any time.
- 4) The transmit RAI bit will be one until basic frame alignment is established, then it will be zero.
- 5) E-bits can be optionally set to zero until the equipment interworking relationship is established. When this has been determined one of the following will take place:
 - a) CRC-to-non-CRC operation - E-bits = 0,
 - b) CRC-to-CRC operation - E-bits as per G.704 and I.431.
- 6) All manual re-frames and new basic frame alignment searches start after the current frame alignment signal position.
- 7) After basic frame alignment has been achieved, loss of frame alignment will occur any time three consecutive incorrect basic frame alignment signals are received. Loss of basic frame alignment will reset the complete framing algorithm.
- 8) When CRC-4 multiframing has been achieved, the primary basic frame alignment and resulting multiframe alignment will be adjusted to the basic frame alignment determined during CRC-4 synchronization. Therefore, the primary basic frame alignment will not be updated during the CRC-4 multiframing search, but will be updated when the CRC-4 multiframing search is complete.

10.3 Reframe

10.3.1 E1 Mode

The MT9076 will automatically force a reframe, if three consecutive frame alignment patterns or three consecutive non-frame alignment bits are in error.

10.3.2 T1 Mode

The MT9076 will automatically force a reframe if the framing bit error density exceeds the threshold programmed by control bits RS1-0 (Framing Mode Select Word page 1H, address 10H). RS1 = RS0 = 0 forces a reframe for 2 errors out of a sliding window of 4 framing bits. RS1 = 0, RS0 = 1 forces a reframe with 2 errors out of 5. RS1 = 1, RS0 = 0 forces a reframe with 2 errors out of 6. RS1 = RS0 = 1 disables the automatic reframe.

In ESF mode, all framing bits are checked. In D4 mode, either Ft bits only (if control bit 2 - FSI - of Framing Mode Select Register is set low) or Ft and Fs bits are checked (FSI set high). If the D4 secondary yellow alarm is enabled (control bit 1 - D4SECY of Transmit Alarm Control Word page 1H, address 11H) then the Fs bit of frame 12 is not verified for the loss of frame circuit.

In E1 or T1 mode, receive transparent mode (selected when bit 3 page 1 address 12H is high) no reframing is forced by the device.

The user may initiate a software reframe at any time by setting bit 1, page 1, address 10H high (ReFR). Once the circuit has commenced reframing the signaling bits are frozen until multiframe synchronization has been achieved.

11.0 MT9076 Channel Signaling

11.1 Channel Signaling in T1 Mode

In T1 mode, when control bit RBE_n (page 1H, address 14H) is low the MT9076 will insert ABCD or AB signaling bits into bit 8 of every transmit DS0 channel every 6th frame. The AB or ABCD signaling bits from received frames 6

and 12 (AB) or from frames 6, 12, 18 and 24 (ABCD) will be loaded into an internal storage RAM. The transmit AB/ABCD signaling nibbles can be passed either via the micro-ports (for channels with bit 1 set high in the Per Time Slot Control Word - pages 7H and 8H) or through related channels of the CSTi serial links, see “ST-BUS vs. DS1 to Channel Relationship(T1)” on page 30. The receive signaling bits are always mapped to the equivalent ST-BUS channels on CSTo. Memory pages five and six contain the transmit AB or ABCD nibbles and pages eight and nine the receive AB or ABCD nibbles for micro-port CAS access.

The serial control streams that contain the transmit / receive signaling information (CSTi and CSTo respectively) are clocked at 2.048 MHz. The number of signaling bits to be transmit / received = 24 (timeslots) x 4 bits per timeslot (ABCD) = 24 nibbles. This leaves many unused nibble positions in the 2.048 MHz CSTi / CSTo bandwidth. These unused nibble locations are tristated. The usage of the bit stream is as follows: the signaling bits are inserted / reported in the same CSTi / CSTo channels that correspond to the DS1 channels used in DSTi / DSTo - see Table 6, “ST-BUS vs. DS1 to Channel Relationship(T1),” on page 30. The control bit MSN (signaling Control Word, page 01H, address 14H) allows for the ABCD bit to use the most significant nibble of CSTi / CSTo (MSN set high) or the least significant nibble (MSN set low). Unused nibbles and timeslots are tristate. In order to facilitate multiplexing on the CSTo control stream, an additional control bit CSToEn (signaling Control Word, page 01H, address 14H) will tristate the whole stream when set low. This control bit is forced low with the reset pin. In the case of D4 trunks, only AB bits are reported. The control bits SM1-0 allow the user to program the 2 unused bits reported on CSTo in the signaling nibble otherwise occupied by CD signaling bits in ESF trunks.

A receive signaling bit debounce of 6 msec. can be selected (DBEn set high - signaling Control Word, page 01H, address 14H). It should be noted that there may be as much as 3 msec. added to this duration because signaling equipment state changes are not synchronous with the D4 or ESF multiframe.

If multi - frame synchronization is lost (page 3H, address 10H, bit 6 $\overline{\text{MFSYNC}} = 1$) all receive signaling bits are frozen. They will become unfrozen when multi - frame synchronization is acquired (this is the same as terminal frame synchronization for ESF links).

When the SIGI interrupt is unmasked, $\overline{\text{IRQ}}$ will become active when a signaling state change is detected in any of the 24 receive channels. The SIGI interrupt mask is located on page 1, address 1EH, bit 0 (set high to enable interrupt); and the SIGI interrupt vector is located on page 4, address 1EH.

11.2 Channel Signaling in E1 Mode

In E1 mode, when control bit TxCCS is set to one, the MT9076 is in Common Channel signaling (CCS) mode. When TxCCS is low it is in Channel Associated signaling mode (CAS). The CAS mode ABCD signaling nibbles can be passed either via the micro-ports (when RPSIG = 1) or through related channels of the CSTo and CSTi serial links (when RPSIG = 0). Memory pages 09H and 0AH contain the receive ABCD nibbles and pages 05H and 06H the transmit ABCD nibbles for micro-port CAS access.

In CAS operation, an ABCD signaling bit debounce of 14 msec. can be selected by writing a one to DBNCE control bit. This is consistent with the signaling recognition time of ITU-T Q.422. It should be noted that there may be as much as 2 msec. added to this duration because signaling equipment state changes are not synchronous with the PCM 30 multiframe.

If multiframe synchronization is lost (page 03H, address 10H, when $\overline{\text{MFSYNC}} = 1$) all receive CAS signaling nibbles are frozen. Receive CAS nibbles will become unfrozen when multiframe synchronization is acquired.

When the CAS signaling interrupt is unmasked (page 01H, address 1EH, SIGIM=1), pin $\overline{\text{IRQ}}$ (pin 12 in PLCC, 65 in LQFP) will become active when a signaling nibble state change is detected in any of the 30 receive channels.

In CCS mode, the data transmitted on channel 16 is sourced from channel 16 data on DSTi.

12.0 Loopbacks

In order to meet PRI Layer 1 requirements and to assist in circuit fault sectioning, the MT9076 has six loopback functions. These are as follows:

a) Digital loopback (DSTi to DSTo at the framer/LIU interface). Bit DLBK = 0 normal; DLBK = 1 activate.

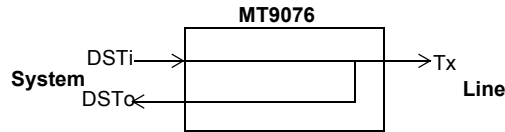

b) Remote loopback (RTIP and RRING to TTIP and TRING respectively at the Line side). Bit RLBK = 0 normal; RLBK = 1 activate.

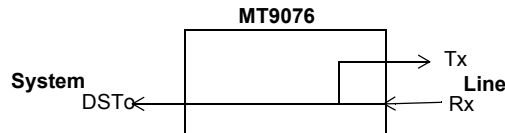

c) ST-BUS loopback (DSTi to DSTo at the system side). Bit SLBK = 0 normal; SLBK = 1 activate.

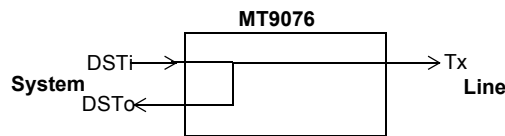

d) Payload loopback (RTIP and RRING to TTIP and TRING respectively at the system side). Bit PLBK = 0 normal; PLBK = 1 activate. The payload loopback is effectively a physical connection of DSTo to DSTi within the MT9076. Sbit information and the DL originate at the point of loopback.

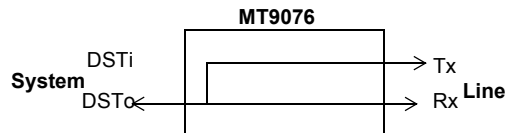

e) Metallic Loopback. MLBK = 0 normal; MLBK = 1 activate, will isolate the external signals RTIP and RRING from the receiver and internally connect the analog output TTIP and TRING to the receiver analog input.

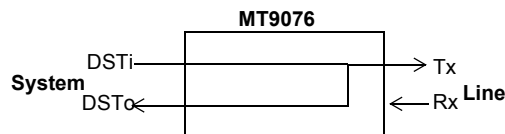

f) Per time slot local and remote loopback. Remote time slot loopback control bit RTSL = 0 normal; RTSL = 1 activate, will loop around transmit ST-BUS time slots to the DSTo stream. Local time slot loopback bits LTSL = 0 normal; LTSL = 1 activate, will loop around receive PCM 30 time slots towards the remote PCM 30 end.

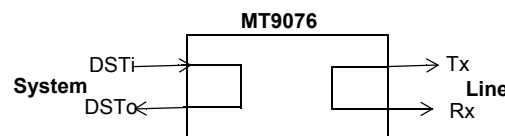

The digital, remote, ST-BUS, payload and metallic loopbacks are located on page 1, address 15H - Coding and Loopback Control Word. The remote and local time slot loopbacks are controlled through control bits 5 and 4 of the Per Time Slot Control Words, pages 7H and 8H.

13.0 Performance Monitoring

13.1 Error Counters

In T1 mode, MT9076 has eight error counters, which can be used for maintenance testing and ongoing measurement of the quality of a DS1 link and to assist the designer in meeting specifications such as TR62411 and T1.403. All counters can be preset or cleared by writing to the appropriate locations.

Associated with each counter is a maskable event occurrence interrupt and a maskable counter overflow interrupt. Overflow interrupts are useful when cumulative error counts are being recorded. For example, every time the framing bit error counter overflow interrupt (FERO) occurs, 256 frame errors have been received since the last FERO (page 04H, address 1DH) interrupt. All counters are cleared and held low by programming the counter clear bit -CNTCLR - high (bit 4 of the Reset Control Word, page 1H, address 1AH). An alternative approach to event reporting is to mask error events and to enable the 1 second sample bit (SAMPLE - bit 3 of the Reset Control Word). When this bit is set the counters for change of frame alignment, loss of frame alignment, line code violation errors, crc errors, errored framing bits, and multiframes out of sync are updated on one second intervals coincident with the maskable one second interrupt timer.

In E1 mode, MT9076 has six error counters, which can be used for maintenance testing, and ongoing measurement of the quality of a PCM 30 link and to assist the designer in meeting specifications such as ITU-T I.431 and G.821. All counters can be preset or cleared by writing to the appropriate locations.

Associated with each counter is a maskable event occurrence interrupt and a maskable counter overflow interrupt. Overflow interrupts are useful when cumulative error counts are being recorded. For example, every time the frame error counter overflow (FERO) interrupt occurs, 256 frame errors have been received since the last FERO interrupt. All counters are cleared and held low by programming the counter clear bit (master control page 01H, address 1A, bit 4) high. Counter overflows set bits in the counter overflow latch (page 04H, address 1FH); this latch is cleared when read.

The overflow reporting latch (page 04H, address 1FH) contains a register whose bits are set when individual counters overflow. These bits stay high until the register is read.

13.2 T1 Counters

13.2.1 Framing Bit Error Counter (FC7-0)

This eight bit counter counts errors in the framing pattern. In ESF mode, any error in the 001011 framing pattern increments the counter. In SLC-96 mode any error in the Ft bit position is counted. In D4 mode Ft errors are always counted, Fs bits (except for the Sbit in frame 12) may optionally be counted (if control bit FSI is set high - page 1H, address 10H, bit 2). The counter is located on page 4H, address 13H.

There are two maskable interrupts associated with the Framing bit error measurement. A single error may generate an interrupt (enable by setting FERI high - bit 7 of the Interrupt Mask Word One, page 1H, address 1CH). A counter overflow interrupt may be enabled by setting control bit FEOM high - bit 2 of Interrupt Mask Word Two (page 1H, address 1DH).

13.2.2 Out Of Frame/Change Of Frame Alignment Counter (OOF3-0/COFA3-0)

This register space is shared by two nibbles. One is the count of out of frame events. The other independent counter is incremented when, after a resynchronization, the frame alignment has moved. This count is reported in page 4, address 13H.

There are two interrupts associated with the Change of Frame Alignment counter. A single error may generate an interrupt (enable by setting COFAI high - bit 4 of the Interrupt Mask Word One, page 1H, address 1CH). A counter overflow interrupt may be enabled by setting control bit COFAO high - bit 4 of Interrupt Mask Word Two (page 1H, address 1DH).

There is one interrupt associated with the Out of Frame counter. A counter overflow interrupt may be enabled by setting control bit OOFO high - bit 5 of Interrupt Mask Word Two (page 1H, address 1DH).

13.2.3 Multiframes out of Sync Counter (MFOOF7-MFOOF0)

This eight bit counter MFOOF7 - MFOOF0 is located on page 4 address 15H, and is incremented once per multiframe (1.5 ms for D4 and 3 ms for ESF) during the time that the framer is out of terminal frame synchronization.

There is a maskable interrupt associated with the measurement. A counter overflow interrupt may be enabled by setting control bit MFOOFO high - bit 1 of Interrupt Mask Word Two (page 1H, address 1DH).

13.2.4 CRC-6 Error Counter (CC15-0)

CRC-6 errors are recorded by this counter for ESF links. This 16 bit counter is located on page 4, addresses 18H and 19H.

There are two maskable interrupts associated with the CRC error measurement. A single error may generate an interrupt (enable by setting CRCI high - bit 6 of the Interrupt Mask Word One, page 1H, address 1CH). A counter overflow interrupt may be enabled by setting control bit CRCO high - bit 6 of Interrupt Mask Word Two (page 1H, address 1DH).

13.2.5 Line Code Violation Error Counter (LCV15-LCV0)

If the control bit EXZ (page 1 address 12H bit 5) is set low, the line code violation error counter will count bipolar violations that are not part of B8ZS encoding. If the control bit EXZ (page 1 address 12H bit 5) is set high, the line code violation error counter will count both bipolar violations that are not part of B8ZS encoding and each occurrence of excess zeros (more than 7 successive zeros in a received B8ZS encoded data stream and more than 15 successive zeros in a non-B8ZS encoded stream). This counter LCV15-LCV0 is 16 bits long (page 4H, addresses 16H and 17H) and is incremented once for every line code violation received. It should be noted that when presetting or clearing the LCV error counter, the least significant LCV counter address should be written to before the most significant location. This counter will suspend operation when terminal frame synchronization is lost if the control bit OOFB is set (bit 2, address 1AH - Reset Control Word).

There are two maskable interrupts associated with the line code violation error measurement. A single error may generate an interrupt (enable by setting LCVI high - bit 3 of the Interrupt Mask Word One, page 1H, address 1CH). A counter overflow interrupt may be enabled by setting control bit LCVO high - bit 3 of Interrupt Mask Word Two (page 1H, address 1DH).

13.2.6 PRBS Error Counter (PS7-0)

There are two 8 bit counters associated with PRBS comparison; one for errors and one for time. Any errors that are detected in the receive PRBS will increment the PRBS Error Rate Counter of page 04H, address 10H. Writes to this counter will clear an 8 bit counter, PSM7-0 (page 01H, address 11H) which counts receive CRC multiframes. A maskable PRBS counter overflow (PRBSO) interrupt (page 1, address 1DH) is associated with this counter.

13.2.7 CRC Multiframe Counter for PRBS (PSM7-0)

This eight bit counter counts receive CRC multiframes. It can be directly loaded via the microport. The counter will also be automatically cleared in the event that the PRBS error counter is written to by the microport. This counter is located on page 04H, address 11H.

13.3 E1 Counters

13.4 Errored FAS Counter (EFAS7-EFAS0)

An eight bit Frame Alignment Signal Error counter EFAS7 - EFAS0 is located on page 04H address 13H, and is incremented once for every receive frame alignment signal that contains one or more errors.

There are two maskable interrupts associated with the frame alignment signal error measurement. FER1 (page 01H, address 1CH) is initiated when the least significant bit of the errored frame alignment signal counter toggles, and FERRO (page 01H, address 1DH) is initiated when the counter changes from FFH to 00H.

13.5 E-bit Counter (EC15-0)

E-bit errors are counted by the MT9076 in order to support compliance with ITU-T requirements. This sixteen bit counter is located on page 04H, addresses 14H and 15H respectively. It is incremented by single error events, with a maximum rate of twice per CRC-4 multiframe.

There are two maskable interrupts associated with the E-bit error measurement. EBI (page 1, address 1CH) is initiated when the least significant bit of the counter toggles, and FEBEO (page 01H, address 1DH) is initiated when the counter overflows.

13.6 Line Code Violation Error Counter (LCV15-LCV0)

If the control bit EXZ (page 1 address 12H bit 5) is set low, the line code violation error counter will count bipolar violations that are not part of HDB3 encoding. If the control bit EXZ (page 1 address 12H bit 5) is set high, the line code violation error counter will count both bipolar violations that are not part of HDB3 encoding and each occurrence of excess zeros (more than 3 successive zeros in a received HDB3 encoded data stream and more than 15 successive zeros in a non-HDB3 encoded stream). This counter LCV15-LCV0 is 16 bits long (page 4H, addresses 16H and 17H) and is incremented once for every line code violation received. It should be noted that when presetting or clearing the LCV error counter, the least significant LCV counter address should be written to before the most significant location. This counter will suspend operation when terminal frame synchronization is lost if the control bit OOFB is set (bit 2, address 1AH - Reset Control Word).

In E1 mode, there are two maskable interrupts associated with the line code violation error measurement. LCVI (page 01H, address 1CH) is initiated when the least significant bit of the LCV error counter toggles. LCVO (page 01H, address 1DH) is initiated when the counter changes from FFFFH to 0000H.

13.7 CRC-4 Error Counter (CC15-0)

CRC-4 errors are counted by the MT9076 in order to support compliance with ITU-T requirements. This sixteen bit counter is located on page 04H, addresses 18H and 19H in E1 mode. It is incremented by single error events, which is a maximum rate of twice per CRC-4 multiframe.

There is a maskable interrupt associated with the CRC error measurement. CRCIM (page 01H, address 1CH) is initiated when the least significant bit of the counter toggles, and CRCOM (page 01H, address 1DH) is initiated when the counter overflows.

13.8 PRBS Error Counter (PS7-0)

There are two 8 bit counters associated with PRBS comparison; one for errors and one for time. Any errors that are detected in the receive PRBS will increment the PRBS Error Rate Counter of page 04H, address 10H. Writes to this counter will clear an 8 bit counter, PSM7-0 (page 01H, address 11H) which counts receive CRC multiframes. A maskable PRBS counter overflow (PRBSO) interrupt (page 1, address 1DH) is associated with this counter.

13.9 CRC Multiframe Counter for PRBS (PSM7-0)

This eight bit counter counts receive CRC-4 multiframes. It can be directly loaded via the microport. The counter will also be automatically cleared in the event that the PRBS error counter is written to by the microport. This counter is located on page 04H, address 11H.

14.0 Error Insertion

In T1 mode, six types of error conditions can be inserted into the transmit DS1 data stream through control bits, which are located on page 1, address 19H - Error Insertion Word. These error events include the bipolar violation errors (BPVE), CRC-6 errors (CRCE), Ft errors (FTE), Fs errors (FSE), payload (PERR) and a loss of signal condition (LOSE). The LOSE function overrides the B8ZS encoding function.

In E1 mode, six types of error conditions can be inserted into the transmit PCM 30 data stream through control bits, which are located on page 01H, address 19H. These error events include the bipolar violation errors (BPVE), CRC-4 errors (CRCE), FAS errors (FASE), NFAS errors (NFSE), payload (PERR) and a loss of signal error (LOSE). The LOSE function overrides the HDB3 encoding function.

15.0 Per Time Slot Control Words

There are two per time slot control pages (addresses AH and BH) (T1/E1) occupying a total of 24 unique addresses in T1 mode or a total of 32 unique addresses in E1 mode. Each address controls a matching timeslot on the 24 DS1 channels (T1) or 32 PCM-30 channels (E1) and the equivalent channel data on the receive (DSTo) data. For example address 0 of the first per time slot control page contains program control for transmit timeslot 0 and DSTo channel 0.

Per Time Slot Control Word

Bit 7 Bit 0
T1 Mode

TXMSG	PCI	RTSL	LTSL	TTST	RRST	RPSIG	CC
-------	-----	------	------	------	------	-------	----

E1 Mode

TXMSG	ADI	RTSL	LTSL	TTST	RRST	RPSIG	---
-------	-----	------	------	------	------	-------	-----

15.1 Clear Channel Capability

In T1 mode, when bit zero (CC) in the per time slot control word is set no bit robbing for the purpose of signaling will occur in this channel. This bit is not used in E1 mode.

15.2 Microport Signaling

When bit one (RPSIG) is set, the transmit signaling for the addressed channel can only be programmed by writing to the transmit signaling page (pages 5H and 6H) via the microport. If zero, the transmit signaling information is constantly updated with the information from the equivalent channel on CSTi.

15.3 Per Time Slot Looping

Any channel or combination of channels may be looped from transmit (sourced from DSTi) to receive (output on DSTo) STBUS channels. When bit four (LTSL) in the Per Time Slot Control Word is set the data from the equivalent transmit timeslot is looped back onto the equivalent receive channel.

Any channel or combination of channels may be looped from receive (sourced from the line data) to transmit (output onto the line) channels. When bit five (RTSL) in the Per Time Slot Control Word is set the data from the equivalent receive timeslot is looped back onto the equivalent transmit channel.

Remote Timeslot Loopback and Local Timeslot should not be simultaneously activated in the same timeslot.

15.4 PRBS Testing

If the control bit ADSEQ is zero (from master control page 1 - access control word), any channel or combination of transmit channels may be programmed to contain a generated pseudo random bit sequence ($2^{15}-1$). The channels are selected by setting bit three (TTST), in the per time slot control word.

If the control bit ADSEQ is zero, any combination of receive channels may be connected to the PRBS decoder ($2^{15}-1$). Each error in the incoming sequence causes the PRBS error counter to increment. The receive channels are selected by setting bit 2 (RRST) in the per time slot control word.

If PRBS is performed during a metallic or external looparound, per time slot control words with TTST set should have RRST set as well.

15.5 Digital Milliwatt

If the control bit ADSEQ is one, a digital milliwatt sequence (Table 18) in T1 mode or (Table 19) in E1 mode may be transmitted on any combination of selected channels. The channels are selected by setting bit three (TTST), in the Per Time Slot Control Word.

Under the same control condition (ADSEQ equal to one), the same digital milliwatt sequence is available to replace received data on any combination of DSTo channels. This is accomplished by setting bit two (RRST) in the Per Time Slot Control Word for the corresponding channel.

Bit 1	Bit 2	Bit 3	Bit 4	Bit 5	Bit 6	Bit 7	Bit 8
0	0	0	1	1	1	1	0
0	0	0	0	1	0	1	1
0	0	0	0	1	0	1	1
0	0	0	1	1	1	1	0
1	0	0	1	1	1	1	0
1	0	0	0	1	0	1	1
1	0	0	0	1	0	1	1
1	0	0	1	1	1	1	0

Table 18 - Digital Milliwatt Pattern (T1)

Bit 1	Bit 2	Bit 3	Bit 4	Bit 5	Bit 6	Bit 7	Bit 8
0	0	1	1	0	1	0	0
0	0	1	0	0	0	0	1
0	0	1	0	0	0	0	1
0	0	1	1	0	1	0	0
1	0	1	1	0	1	0	0
1	0	1	0	0	0	0	1
1	0	1	1	0	0	0	1
1	0	1	1	0	1	0	0

Table 19 - A-Law Digital Milliwatt Pattern (E1)

15.6 Per Channel Inversion

When bit six (PCI) in the Per Time Slot Control Word is set both transmit and receive data for the selected channel is inverted before going onto the line / DSTo respectively.

15.7 Transmit Message

When bit seven (TXMSG) in the Per Time Slot Control Word is set the data transmit in the selected channel is sourced from the transmit message word in Master Control page 1.

16.0 Alarms

The following alarms are detected by the receiver in T1 mode. Each may generate a maskable interrupt:

- D4 Yellow Alarm - In D4 mode there are two possible yellow alarm signals. If control bit D4SECY is set low, (page 1H, address 11H, bit 1) the criteria for a yellow alarm is an excess of 0's (more than 285) in bit position 2 of incoming DS0 channels during an integration period of 1.5 milliseconds. It is cleared after more than 3'1's are detected in bit position 2 of normal data in a 1.5 millisecond integration period. If D4SECY is set high the secondary yellow alarm is selected. The detection criteria becomes 2 consecutive '1's in the Sbit position of the 12th frame.
- ESF Yellow Alarm - In ESF mode, there are two possible yellow alarm signals. If control bit JYEL (page 1H, address 14H, bit 0) is set low the criteria for a yellow alarm is a pattern 00000000 11111111 in seven or more code words out of ten, If JYEL is set high, the criteria for a yellow alarm is a pattern 11111111 11111111 in seven or more code words out of ten.
- All Ones - This bit (page 3H, address 11H, bit 3) is set if less than six zeros are received on the incoming line data during a 3 ms interval
- Loss of Signal - a loss of signal condition occurs when the receive signal level is lower than 20 dB or 40 dB below the nominal signal level for at least a millisecond or when 32 or 192 (control bit L32Z (page 01H, address 19H, bit 1) consecutive zeros have been received. A loss of signal condition will terminate when an average ones density of at least 12.5% has been received over a period of 193 contiguous pulse positions starting with a pulse. The loss of signal is reported in the Receive Signal Status Word - (page 3, address 16H bit 4).

The following alarms are detected by the receiver in E1 mode. Each may generate a maskable interrupt:

- Remote Alarm Indication (RAI) - bit 3 (A) of the receive NFAS;
- Alarm Indication Signal (AIS) - unframed all ones signal for at least a double frame (512 bits) or two double frames (1024 bits);
- Channel 16 Alarm Indication Signal - all ones signal in channel 16;

- Auxiliary pattern - 101010... pattern for at least 512 bits;
- Loss of Signal - a loss of signal condition occurs when the receive signal level is lower than 20 dB or 40 dB (by setting the bit ELOS on page 02H, address 10H, bit 3) below the nominal signal level for more than a millisecond or when more than 32 or 192 (control bit L32Z (page 01H, address 19H 9 bit 1) zeros have been received in a row. A loss of signal condition will terminate when an average ones density of at least 12.5% has been received over a period of 192 contiguous pulse positions starting with a pulse.
- Remote signaling Multiframe Alarm - (Y-bit) of the multiframe alignment signal.

The alarm reporting latch (page 04H, address 12H) contains a register whose bits are set high for selected alarms. These bits stay high until the register is read. This allows the controller to record intermittent or sporadic alarm occurrences.

16.1 Automatic Alarms

In E1 mode, the transmission of RAI and signaling multiframe alarms can be made to function automatically from control bits $\overline{\text{ARAI}}$ and $\overline{\text{AUTY}}$ (page 01H, address 10H). When $\overline{\text{ARAI}} = 0$ and basic frame synchronization is lost ($\overline{\text{SYNC}} = 1$), the MT9076 will automatically transmit the RAI alarm signal to the far end of the link. The transmission of this alarm signal will cease when basic frame alignment is acquired.

When $\overline{\text{AUTY}} = 0$ and signaling multiframe alignment is not acquired ($\overline{\text{MFSYNC}} = 1$), the MT9076 will automatically transmit the multiframe alarm (Y-bit) signal to the far end of the link. This transmission will cease when signaling multiframe alignment is acquired.

17.0 Detected Events

17.1 T1 Mode

17.1.1 Severely Errored Frame Event

In T1 mode, bit 5 page 3H address 10H toggles whenever a sliding window detects 2 framing errors events (Ft or ESF) in a sliding window of 6.

17.1.2 Loop Code Detect

T1.403 defines SF mode line loopback activate and deactivate codes. These codes are either a framed or un-framed repeating bit sequence of 00001 for activation or 001 for deactivation. The standard goes on to say that these codes will persist for five seconds or more before the loopback action is taken. In T1 mode MT9076 will detect both framed and unframed line activate and de-activate codes even in the presence of a BER of 3×10^{-3} . Line Loopback Disable Detect - LLDD - in the Alarm Status Word (bit 0 address 11H of page 3H) will be asserted when a repeating 001 pattern (either framed or unframed) has persisted for 48 milliseconds. Line Loopback Enable Detect LLED in the Alarm Status Word will be asserted when a repeating 00001 pattern (either framed or unframed) has persisted for 48 milliseconds.

17.1.3 Pulse Density Violation Detect

In T1 mode, bit 2 of address 11H on page 3H (PDV) toggles if the receive data fails to meet ones density requirements. It will toggle upon detection of 16 consecutive zeros on the line data, or if there are less than N ones in a window of $8(N+1)$ bits - where N = 1 to 23.

17.1.4 Timer Outputs

In T1 mode, MT9076 has a one second timer derived from the 20 MHz oscillator pins. The timer may be used to trigger interrupts for T1.403/408 performance messaging.

17.2 E1 mode

17.2.1 Consecutive Frame Alignment Patterns (CONFAP)

Two consecutive frame alignment signals in error.

17.2.2 Receive Frame Alignment Signals

These bits are received on the PCM 30 and link in bit positions two to eight of time slot 0 - frame alignment signal. These signals form the frame alignment signal and should be 0011011.

17.2.3 Receive Non Frame Alignment Signal

This signal is received on the PCM 30 and link in bit position two of time slot 0 - non frame alignment signal.

17.2.4 Receive Multiframe Alignment Signals

These signal are received on the PCM 30 and link in bit position one to four of time slot 16 of frame zero of every signaling multiframe.

18.0 Interrupts

The MT9076 has an extensive suite of maskable interrupts, which are divided into four categories based on the type of event that caused the interrupt. Each interrupt has an associated mask and interrupt bit. When an unmasked interrupt event occurs, \overline{IRQ} will go low and one or more bits of the appropriate interrupt register will go high(T1/E1). After each interrupt register is read it is automatically cleared. When all interrupt registers are cleared \overline{IRQ} will return to a high impedance state. This function can also be accomplished by toggling the INTA bit (page 01H, address 1AH, bit 5).

All the interrupts of the MT9076 in T1 and E1 mode are maskable. This is accomplished through interrupt mask words zero to three, which are located on page 1, addresses 1BH to 1EH and the (optional) HDLC interrupt mask located at address 16 of page B.

After a MT9076 reset (\overline{RESET} pin or RST control bit), all interrupts are masked.

All interrupts may be suspended, without changing the interrupt mask words, by making the SPND control bit of page 1, address 1AH high.

All interrupts are cleared by forcing the pin \overline{TxAO} low

18.1 Interrupts on T1 Mode

Interrupt Word Zero (Page 4, Address 1BH)							
Bit 7				Bit 0			
TFSYNI	MFSYNI	TSAI	AISI	LOSI	SEI	TxSLPI	RxSLPI

Interrupt Mask Word Zero (Page 1, Address 11BH)							
Bit 7				Bit 0			
TFSYNIM	MFSYNIM	BIOMTIM	AISIM	LOSIM	SEFIM	TxSLPIM	RxSLPIM

Interrupt Word One (Page 4, Address 1CH)							
Bit 7				Bit 0			
FEI	CRCI	YELI	COFAI	LCVI	PRBSI	PDVI	---

Interrupt Mask Word One (Page 1, Address 1CH)							
Bit 7							Bit 0
FEIM	CRCIM	YELIM	COFAIM	LCVIM	PRBSIM	PDVIM	---

Interrupt Word Two (Page 4, Address 1DH)							
Bit 7							Bit 0
FEO	CRCO	OOF0	COFA0	LCVO	PRBS0	MFOOFO	---

Interrupt Mask Word Two (Page 1, Address 1DH)							
Bit 7							Bit 0
FEOM	CRCOM	OOFOM	COFAOM	LCVOM	PRBSOM	PRBSMFOM	MFOOFOM

Interrupt Word Three (Page 4, Address 1EH)							
Bit 7							Bit 0
HDLC0I	HDLC1I	HDLC2I	LCDI	1SECI	5SECI	BIOMI	SIGI

Interrupt Mask Word Three (Page 1, Address 1EH)							
Bit 7							Bit 0
HDLC0IM	HDLC1IM	HDLC2IM	LCDIM	LSECIM	5SECIM	BIOMIM	SIGIM

HDLC Interrupt Status Register (Page B,C, & D, Address 17H)							
Bit 7							Bit 0
GA	RxEOP	TxEOP	RxFE	TxFL	FATxUNDER	RxFF	RxOVF

HDLC Interrupt Mask Register (Page B, C, and D Address 16H)							
Bit 7							Bit 0
GAIM	RxEOPIM	TxEOPIM	RxFEIM	TxFLIM	FA:TxUNDERIM	RxFFIM	RxOVFIM

18.2 Interrupts on E1 Mode

Interrupt Word Zero (Page 4, Address 1BH)								Interrupt Mask Word Zero (Page 1, Address 1BH)							
Bit 7							Bit 0	Bit 7					Bit 0		
TFSYNI	MFSYNI	CRCSYNI	AISI	LOSI	CEFI	Y1	RxSLPI	SYNIM	MFSYM	CSYNIM	AISIM	LOSIM	CEFIM	YIM	SLPIM

Interrupt Word One (Page 4, Address 1CH)								Interrupt Mask Word One (Page 1, Address 1CH)							
Bit 7							Bit 0	Bit 7					Bit 0		
FERRI	CRCERRI	EBITI	AIS16I	LCVI	PRBSERRI	AUXPI	RAII	FERIM	CRCIM	EMIM	AISI6IM	LCVIM	PRBSIM	AUXPIM	RAIIM

Interrupt Word Two (Page 4, Address 1DH)								Interrupt Mask Word Two (Page 1, Address 1DH)							
Bit 7							Bit 0	Bit 7					Bit 0		
FERRO	CRCO	---	FEBFO	LCVO	PRBS0	PRBSMFO	Sal	FEOM	CRCOIM	---	EBOIM	LCVCOM	PRBSOM	PRBSMFOM	SalM

Interrupt Word Three (Page 4, Address 1EH) Bit 7 Bit 0								Interrupt Mask Word Three (Page 1, Address 1EH) Bit 7 Bit 0							
HDLC0I	HDLC1I	HDLC2I	JAI	1SECI	5SECI	RCRI	SIGI	HDLC0IM	HDLC1IM	HDLC2IM	LCDIM	LSECIM	5SECIM	BIOMIM	SIGIM

HDLC Interrupt Status Register (Page B, C & D, Address 17H) Bit 7 Bit 0								HDLC Interrupt Mask Register (Page B, C, & D, Address 16H) Bit 7 Bit 0							
GA	RxEOP	TxEOP	RxFE	TxFL	FA:TxUNDER	RxFF	Rx6VF	GAIM	RxEOPIM	TxEOPIM	RxFEIM	TxFLIM	FA:TxUNDERIM	RxFFIM	RxOVFIM

19.0 Digital Framer Mode

19.1 T1 Mode

Setting bit 4 in the Configuration Control Word (address 10H of Master Control Page 2) disables the LIU and converts the MT9076 into a digital T1 transceiver. The digital 2.048 Mb/s ST-BUS backplane maps into transmit and receive digital 1.544 Mb/s streams. The 1.544 Mb/s transmit streams may be formatted for single phase NRZ (by setting bit 7 of the LIU Control Word - Master Page 1 high) or two phase NRZ. The data rate conversion (between 2.048 Mb/s and 1.544 Mb/s) is done within the MT9076. The transmit 1.544 MHz clock is internally generated from a PLL that locks onto the input C4b clock. This clock is then output on pin E1.5o/Exclk (PLCC pin 44 - LQFP pin 22). The digital 1.544 Mb/s transmit data is output on pins TXA and TXB (PLCC pins 37,38 - LQFP pins 12, 13) with the rising edge of pin Exclk. If the control bit Tx8KEN is set high (page 2H address 10H bit 2) the pin RxMF/TxFP will generate an 8 KHz positive frame pulse synchronous with the Sbit clocked out on TXA/TXB. Receive digital data is clocked in on pins RRING and RTIP. This data is clocked in with the rising edge of the input 1.544 MHz clock S/FR/Exclki (PLCC pin 66, LQFP pin 48).

19.2 E1 mode

Setting bit 4 in the Configuration Control Word (address 10H of Master Control Page 2) disables the LIU and converts the MT9076 into a digital E1 transceiver. The digital 2.048 Mb/s ST-BUS backplane maps into transmit and receive digital 2.048 Mb/s streams. The 2.048 Mb/s transmit data streams may be formatted for single phase NRZ (by setting bit 7 of the LIU Control Word - Master Page 1 high) or two phase NRZ. The transmit 2.048 MHz clock is derived from the input C4b clock. This clock is then output on pin Exclk (PLCC pin 44 - LQFP pin 22). The digital 2.048 Mb/s transmit data is output on pins TXA and TXB (PLCC pins 37,38 - LQFP pins 12, 13) with the rising edge of Exclk. If the control bit Tx8KEN is set high (page 2H address 10H bit 2) the pin RxMF/TxFP will generate an 8 KHz positive frame pulse synchronous with the Sbit clocked out on TXA/TXB. Receive digital data is clocked in on pins RRING and RTIP. This data is clocked in with the rising edge of the input 2.048 MHz clock S/FR/Exclki (PLCC pin 66, LQFP pin 48).

20.0 Control and Status Registers

20.1 T1 Mode

20.1.1 Master Control 1 (Page 01H) (T1)

Address (A ₄ A ₃ A ₂ A ₁ A ₀)	Register	Function
10H (Table 21)	Framing Mode Select	ESF, SCL96, CXC, RS1-0, FSI, ReFR, MFReFR
11H (Table 22)	Transmit Alarm Control Word	ESFYEL, TXSECY, D4YEL, $\overline{\text{TxAO}}$, LUA, LDA, D4SECY, SO
12H (Table 23)	Data Link Control Word	EDL, BIOMEn, EXZ, TxPDVS, TxSYNC, TRSP, JTS, H1R64
13H (Table 24)	Transmit Bit Oriented Message	BIOMTx7-0
14H (Table 25)	Signaling Control Word	DSToEn, CSToEn, RBEEn, DBEn, MSN, SM1-0, JYEL
15H (Table 26)	Coding and Loopback Control Word	RxB8ZS, MLBK, TxB8ZS, FBS, DLBK, RLBK, SLBK, PLBK
16H	Reserved	Set all bits to zero for normal operation
17H (Table 27)	Transmit Elastic buffer Set Delay Word	TxTSD7-0
18H (Table 28)	Transmit Message Word	TXM7-0
19H (Table 29)	Error Insertion Word	BPVE, CRCE, FTE, FSE, LOSE, PERR, L3Z2, LOS/LOF
1AH (Table 30)	Reset Control Word	RST, SPND, INTA, CNTCLR, SAMPLE, OOFF, D20
1BH (Table 31)	Interrupt Mask Word Zero	TFSYNIM, MFSYNIM, BIOMTIM, AISIM, LOSIM, SEFIM, TxSLPIM, RxSLPIM
1CH (Table 32)	Interrupt Mask Word One	FEIM, CRCIM, YELIM, LCVIM, COFAIM, PRBSIM, PDVIM
1DH (Table 33)	Interrupt Mask Word Two	FEOM, CRCOM, OOFOM, COFAOM, LCVOM, PRBSOM, PRBSMFOM, MFOOFOM
1EH (Table 34)	Interrupt Mask Word Three	HDLC0IM, HDLC1IM, HDLC2IM, LCDIM, 1SECIM, 5SECIM, BIOIM, SIGIM
1FH (Table 35)	LIU Receiver Word	NRZ, Res, RxA1-0, RxEQ2-0

Table 20 - Master Control 1 (Page 1) (T1)

Bit	Name	Functional Description
7	ESF	Extended Super Frame. Setting this bit enables transmission and reception of the 24 frame superframe DS1 protocol.
6	SLC96	SLC96 Mode Select. Setting this bit enables input and output of the Fs bit pattern on the TxDL and RxDL pins. Frame synchronization is the same as in the case of D4 operation. The transmitter will insert A and B bits every 6 frames after synchronizing to the Fs pattern clocked into Txdl. Receive Fs bits are not monitored for the Framing Bit Error Counter.
5	CXC	Cross Check. Setting this bit in ESF mode enables a cross check of the CRC-6 remainder before the frame synchronizer pulls into sync. This process adds at least 6 milliseconds to the frame synchronization time. Setting this bit in D4 (not ESF) mode enables a check of the Fs bits in addition to the Ft bits during frame synchronization
4 - 3	RS1- 0	Reframe Select 1 - 0. These bits set the criteria for an automatic reframe in the event of framing bits errors. The combinations available are: RS1 - 0, RS0 - 0 = sliding window of 2 errors out of 4. RS1 - 0, RS0 - 1 = sliding window of 2 errors out of 5. RS1 - 1, RS0 - 0 = sliding window of 2 errors out of 6. RS1 - 1, RS0 - 1 = no reframes due to framing bit errors.
2	FSI	Fs Bit Include. Only applicable in D4 mode (not ESF or SLC96). Setting this bit causes errored Fs bits to be included as framing bit errors. A bad Fs bit will increment the Framing Error Bit Counter, and will potentially cause a reframe (if it is the second bad framing bit out of 5). The Fs bit of the receive frame 12 will only be included if D4SECY is set.
1	ReFR	Reframe. A low - to - high transition on this bit causes an automatic reframe.
0	MFRReFR	MultiFrame Reframe. Only applicable in D4 or SLC96 mode. A low - to - high transition on this bit causes an automatic multiframe reframe. The signaling bits are frozen until multiframe synchronization is achieved. Terminal frame synchronization is not affected.

Table 21 - Framing Mode Select (T1)
(Page 1, Address 10H)

Bit	Name	Functional Description
7	ESFYEL	ESF Yellow Alarm. Setting this bit while in ESF mode causes a repeating pattern of eight 1's followed by eight 0's to be inserted onto the transmit FDL (Japan Telecom bit set low - see Signalling Control Word) or sixteen 1's (Japan Telecom bit set high).
6	TXSECY	Transmit Secondary D4 Yellow Alarm. Setting this bit (in D4 mode) causes the S bit of transmit frame 12 to be set.
5	D4YEL	D4 Yellow Alarm. When set bit 2 of all DS0 channels are forced low.
4	$\overline{\text{TxAO}}$	Transmit All Ones. When low, this control bit forces a framed or unframed (depending on the state of Transmit Alarm Control bit 0) all ones to be transmit at TTIP and TRING.
3	LUA	Loop Up Activate. Setting this bit forces transmission of a framed or unframed (depending on the state of Transmit Alarm Control bit 0) repeating pattern of 00001.
2	LDA	Loop Down Activate. Setting this bit forces transmission of a framed or unframed (depending on the state of Transmit Alarm Control bit 0) repeating pattern of 001.
1	D4SECY	D4 Secondary Alarm. Set this bit for trunks employing the secondary Yellow Alarm. The Fs bit in the 12th frame will not be used for counting errored framing bits. If a one is received in the Fs bit position of the 12th frame a Secondary Yellow Alarm Detect bit will be set.
0	SO	Overhead bits Override. If set, this bit forces the overhead bits to be inserted as an overlay on any of the following alarm conditions: i) transmit all ones, ii) loop up code insertion, iii) loop down code insertion.

Table 22 - Transmit Alarm Control Word (T1)

(Page 1, Address 11H)

Bit	Name	Functional Description
7	EDL	Enable Data Link. Setting this bit multiplexes the serial stream clocked in on pin TxDL into the FDL bit position (ESF mode) or the Fs position (D4 mode).
6	BIOMEn	Bit Oriented Messaging Enable. Setting this bit enables transmission of bit - oriented messages on the ESF facility data link. The actual message transmit at any one time is contained in the BIOMTx register (page 1, address 13H). The receive bit - oriented message register is always active, although the interrupt associated with it may be masked.
5	EXZ	Excess Zeros. Setting this bit causes each occurrence of received excess zeros to increment the Line Code Violation Counter. Excess zeros are defined as 8 or more successive zeros for B8ZS encoded data, or 16 or more successive zeros for non-B8ZS encoded data.
4	TxPDVS	Transmit Pulse Density Violation Screen. Setting this bit causes ones to be injected into the transmit data in the event that a violation of the ones density requirement is detected in the outgoing data.
3	TxSYNC	Transmit Synchronization. Setting this bit causes the transmit multiframe boundary to be internally synchronized to the incoming Sbits on DSTi channel 31 bit 0.
2	TRSP	Transparent Mode. Setting this bit causes unframed data to be transmit from DSTi channels 0 to 23 and channel 31 bit 0 to be transmit transparently onto the DS1 line. Unframed data received from the DS1 line is piped out on DSTo channels 0 to 23 and channel 31 bit 0.
1	JTS	Japan Telecom Synchronization. Setting this bit forces the inclusion of Sbits in the CRC-6 calculation.
0	H1R64	HDLC Rate Select. Setting this pin high while an HDLC is activated on a timeslot enables 64 Kb/s operation. Setting this pin low while an HDLC is activated enables 56 Kb/s operation (this prevents data corruption due to forced bit stuffing).

Table 23 - Data Link Control Word (T1)

(Page 1, Address 12H)

Bit	Name	Functional Description
7 - 0	BIOMTx7-0	Transmit Bit Oriented Message. The contents of this register are concatenated with a sequence of eight 1's and continuously transmit in the FDL bit position of ESF trunks. Normally the leading bit (bit 7) and last bit (bit 0) of this register are set to zero.

Table 24 - Transmit Bit Oriented Message (T1)

(Page 1, Address 13H)

Bit	Name	Functional Description
7	DSToEn	DSTo Enable. If zero pin DSTo is tristate. If set the pin DSTo is enabled.
6	CSToEn	CSTo Enable. If zero pin CSTo is tristate. If set the pin CSTo is enabled.
5	RBEn	Robbed Bit signaling Enable. Setting this bit multiplexes the AB or ABCD signaling bits into bit position 8 of all DS0 channels every 6th frame.
4	DBEn	Debounce Enable. Setting this bit causes incoming signaling bits to be debounced for a period of 6 to 9 milliseconds before reporting on CSTo or in the Receive signaling Bits Page.
3	MSN	Most Significant Nibble. If set to one the most significant nibble of CSTi and CSTo are activated. The reporting stream CSTo contains the signaling information for the equivalent channel in the most significant nibble, and least significant nibble is tristate. If set to zero the least significant nibble is active for CSTi and CSTo and the most significant nibble of CSTo is tristate.
2-1	SM1-0	signaling Message. These two bits are used to fill the vacant bit positions available on CSTo when the 3VJET is operating on a D4 trunk. The first two bits of each reporting nibble of CSTo contain the AB signaling bits. The last two will contain SM1 and SM0 (in that order). When the 3VJET is connected to ESF trunks four signaling bits (ABCD) are reported and the bits SM1-0 become unused.
0	JYEL	Japan Yellow Alarm Set this bit high to selects a pattern of 16 ones (1111111111111111) as the ESF yellow alarm, both for the case when an ESF yellow alarm is to be transmitted, or in recognizing a received yellow alarm.

Table 25 - Signaling Control Word (T1)

(Page 1, Address 14H)

Bit	Name	Functional Description
7	RxB8ZS	Receive B8ZS Enable. If one, receive B8ZS decoding is enabled.
6	MLBK	Metallic Loopback. If one, then RRTIP/RRING are connected directly to TTIP and TRING respectively. If zero, then this feature is disabled.
5	TxB8ZS	Transmit B8ZS Enable. If one, all zero octets are substituted with B8ZS codes.
4	FBS	Forced Bit Stuffing. If set any transmit DS0 channel containing all zeros has bit 7 forced high.
3	DLBK	Digital Loopback. If one, then the digital stream to the transmit LIU is looped back in place of the digital output of the receive LIU. Data coming out of DSTo will be a delayed version of DSTi. If zero, this feature is disabled.
2	RLBK	Remote Loopback. If one, then all time slots received on RRTIP/RRING are connected to TTIP/TRING on the DS1 side of the 3VJET. If zero, then this feature is disabled.
1	SLBK	ST-BUS Loopback. If one, then all time slots of DSTi are connected to DSTo on the ST-BUS side of the 3VJET. If zero, then this feature is disabled. See Loopbacks section.
0	PLBK	Payload Loopback. If one, then all time slots received on RTIP/RRING are connected to TTIP/TRING on the ST-BUS side of the 3VJET. If zero, then this feature is disabled.

Table 26 - Coding and Loopback Control Word (T1)

(Page 1, Address 15H)

Bit	Name	Functional Description
7-0	TxSD7-0	Transmit Set Delay Bits 7-0. Writing to this register forces a one time setting of the delay through the transmit slip buffer. The delay is defined as the time interval between the write of the transmit STBUS channel containing DS1 timeslot 1 and its subsequent read. The delay is modified by moving the position of the internally generated DS1 frame boundary. The delay (when set) will always be less than 1 frame (125 uS). This register must be programmed with a non - zero value.

Table 27 - Transmit Elastic Buffer Set Delay Word (T1)

(Page 1, Address 17H)

Bit	Name	Functional Description
7-0	TxM7-0	Transmit Message Bits 7 - 0. The contents of this register are transmit into those outgoing DS1 channels selected by the Per Time Slot Control registers.

Table 28 - Transmit Message Word (T1)

(Page 1, Address 18H)

Bit	Name	Functional Description
7	BPVE	Bipolar Violation Error Insertion. A zero-to-one transition of this bit inserts a single bipolar violation error into the transmit DS1 data. A one, zero or one-to-zero transition has no function.
6	CRCE	CRC-6 Error Insertion. A zero-to-one transition of this bit inserts a single CRC-6 error into the transmit ESF DS1 data. A one, zero or one-to-zero transition has no function.
5	FTE	Terminal Framing Bit Error Insertion. A zero-to-one transition of this bit inserts a single error into the transmit D4 Ft pattern or the transmit ESF framing bit pattern (in ESF mode). A one, zero or one-to-zero transition has no function.
4	FSE	Signal Framing Bit Error Insertion. A zero-to-one transition of this bit inserts a single error into the transmit Fs bits (in D4 mode only). A one, zero or one-to-zero transition has no function.
3	LOSE	Loss of Signal Error Insertion. If one, the 3VJET transmits an all zeros signal (no pulses). Zero code suppression is overridden. If zero, data is transmitted normally.
2	PERR	Payload Error Insertion. A zero - to - one transition of this bit inserts a single bit error in the transmit payload. A one, zero or one-to-zero transition has no function.
1	L32Z	Digital Loss of Signal Selection. If one, the threshold for digital loss of signal is 32 successive zeros. If zero, the threshold is set to 192 successive zeros.
0	LOS/LOF	Loss of Signal or Loss of Frame Selection. If one, pin LOS will go high when a loss of signal state exits (criteria as per LLOS status bit). If low, pin LOS will go high when either a loss of signal or a loss of frame alignment state exits.

Table 29 - Error Insertion Word (T1)

(Page 1, Address 19H)

Bit	Name	Functional Description
7	RST	Software reset. Setting this bit is equivalent to performing a hardware reset. All counters are cleared and the control registers are set to their default values. This control bit is internally cleared after the reset operation is complete.
6	SPND	Suspend Interrupts. If one, the $\overline{\text{IRQ}}$ output will be in a high-impedance state and all interrupts will be ignored. If zero, the $\overline{\text{IRQ}}$ output will function normally.
5	INTA	Interrupt Acknowledge. Setting this pin clears all interrupts and forces the $\overline{\text{IRQ}}$ pin into high impedance. The control bit itself is then internally cleared.
4	CNTCLR	Counter Clear. If one, all status error counters are cleared and held low.
3	SAMPLE	One Second Sample. Setting this bit causes the error counters (change of frame alignment, loss of frame alignment, LCV errors, CRC errors, severely errored frame events and multiframes out of sync) to be updated on one second intervals coincident with the one second timer (status page 3 address 12H bit 7).
2	OOF	Out of Frame Pause. If set high, this bit will suspend operation of the Line Code Violation Counter during an out - of - frame condition; upon achieving terminal frame synchronization the counter will resume normal operation. If set low, the Line Code Violation counter will continue to count errors even if terminal frame synchronization is lost.
1	--	Reserved. Set to zero for normal operation.
0	D20	Double20. Set to zero for normal operation. Set high to double clock speed in the HDLC, speeding up microport accesses from 160 ns between consecutive reads/writes to 80 ns between consecutive reads/writes.

Table 30 - Reset Control Word (T1)

(Page 1, Address 1AH)

Bit	Name	Functional Description
7	TFSYNIM	Terminal Frame Synchronization Interrupt Mask. When unmasked an interrupt is initiated whenever a change of state of loss of terminal frame synchronization condition exists. If 1 - unmasked, 0 - masked.
6	MFSYNIM	Multiframe Synchronization Interrupt Mask. When unmasked an interrupt is initiated whenever a change of state of loss of multiframe synchronization condition exist. If 1 - unmasked, 0 - masked
5	BIOMTIM	Bit Oriented Message Transition Interrupt Mask. When unmasked an interrupt is initiated whenever a new BIOM arrives or if the current BIOM stops transmission. If 1 - unmasked, 0 -masked.
4	AISIM	Alarm Indication Signal Interrupt Mask. When unmasked a change of state of received all ones condition will initiate an interrupt. If 1 - unmasked, 0 - masked.
3	LOSIM	Loss of Signal Interrupt Mask. When unmasked an interrupt is initiated whenever a change of state of a loss of signal condition exists. If 1 - unmasked, 0 - masked.
2	SEFIM	Severely Errored Frame Interrupt Mask. When unmasked an interrupt is initiated when a sequence of 2 framing errors out of 6 occurs. If 1 - unmasked, 0 - masked.
1	TxSLPIM	Transmit SLIP Interrupt Mask. When unmasked an interrupt is initiated whenever a controlled frame slip occurs in the transmit elastic buffer. If 1 - unmasked, 0 - masked.
0	RxSLPIM	Receive SLIP Interrupt Mask. When unmasked an interrupt is initiated whenever a controlled frame slip occurs in the receive elastic buffer. If 1 - unmasked, 0 - masked.

Table 31 - Interrupt Mask Word Zero (T1)

(Page 1, Address 1BH)

Bit	Name	Functional Description
7	FEIM	Framing Bit Error Interrupt Mask. When unmasked an interrupt is initiated whenever an erroneous framing bit is detected (provided the circuit is in terminal frame sync). If 1 - unmasked, 0 - masked.
6	CRCIM	CRC-6 Error Interrupt Mask. When unmasked an interrupt is initiated whenever a local CRC-6 error occurs. If 1 - unmasked, 0 - masked.
5	YELIM	Yellow Alarm Interrupt Mask. When unmasked detection of a yellow alarm triggers an interrupt. If 1 - unmasked, 0 - masked.
4	COFAIM	Change of Frame Alignment Interrupt Mask. When unmasked an interrupt is initiated whenever a change of frame alignment occurs after a reframe. If 1 - unmasked, 0 - masked.
3	LCVIM	Line Code Violation Interrupt Mask. When unmasked an interrupt is initiated whenever a line code violation (excluding B8ZS bipolar violations encoding) is encountered. If 1- unmasked, 0 - masked.
2	PRBSIM	Pseudo Random Bit Sequence Error Interrupt Mask. When unmasked an interrupt will be generated upon detection of an error with a channel selected for PRBS testing. If 1 - unmasked, 0 - masked.
1	PDVIM	Pulse Density Violation Interrupt Mask. When unmasked an interrupt is triggered whenever a sequence excess consecutive zeros is received on the line. If 1 - unmasked, 0 - masked.
0	- - -	Unused.

Table 32 - Interrupt Mask Word One (T1)

(Page 1, Address 1CH)

Bit	Name	Functional Description
7	FEOM	Framing Bit Error Counter Overflow Interrupt Mask. When unmasked an interrupt is initiated whenever the framing bit error counter changes from FFH to 00H. If 1 - unmasked, 0 - masked.
6	CRCOM	CRC-6 Error Counter Overflow Interrupt Mask. When unmasked an interrupt is initiated whenever the CRC-6 error counter changes from FFH to 00H. If 1 - unmasked, 0 - masked.
5	OOFOM	Out Of Frame Counter Overflow Interrupt Mask. When unmasked an interrupt is initiated whenever the out of frame counter changes state from changes from FFH to 00H. If 1 - unmasked, 0 - masked.
4	COFAOM	Change of Frame Alignment Counter Overflow Interrupt Mask. When unmasked an interrupt is initiated whenever the change of frame alignment counter changes from FFH to 00H. If 1 - unmasked, 0 - masked.
3	LCVOM	Line Code Violation Counter Overflow Interrupt Mask. When unmasked an interrupt is initiated whenever the line code violation counter changes from FFH to 00H. If 1 - unmasked, 0 - masked.
2	PRBSOM	Pseudo Random Bit Sequence Error Counter Overflow Interrupt Mask. When unmasked an interrupt will be generated whenever the PRBS error counter changes from FFH to 00H. If 1 - unmasked, 0 - masked.
1	PRBSMFOM	Pseudo Random Bit Sequence Multiframe Counter Overflow Interrupt Mask. When unmasked an interrupt will be generated whenever the multiframe counter attached to the PRBS error counter overflows. FFH to 00H. If 1 - unmasked, 0 - masked.
0	MFOOFOM	Multiframes Out Of Sync Overflow Interrupt Mask. When unmasked an interrupt will be generated when the multiframes out of frame counter changes from FFH to 00H. If 1 - unmasked, 0 - masked.

Table 33 - Interrupt Mask Word Two (T1)

(Page 1, Address 1DH)

Bit	Name	Functional Description
7	HDLC0IM	HDLC0 Interrupt Mask. When unmasked an interrupt is triggered by an unmasked event in HDLC0. If 1 - unmasked, 0 - masked.
6	HDLC1IM	HDLC1 Interrupt Mask. When unmasked an interrupt is triggered by an unmasked event in HDLC1. If 1 - unmasked, 0 - masked.
5	HDLC2IM	HDLC2 Interrupt Mask. When unmasked an interrupt is triggered by an unmasked event in HDLC2. If 1 - unmasked, 0 - masked.
4	LCDIM	Loop Code Detected Interrupt Mask. When unmasked an interrupt is triggered when either the loop up (00001) or loop down (001) code has been detected on the line for a period of 48 milliseconds. If 1 - unmasked, 0 - masked.
3	1SECIM	One Second Status Interrupt Mask. When unmasked an interrupt is initiated when the 1SEC status bit (page 3 address 12H bit 7) goes from low to high. If 1 - unmasked, 0 - masked.
2	5SECIM	Five Second Status Interrupt Mask. When unmasked an interrupt is initiated when the 5 SEC status bit goes from low to high. If 1 - unmasked, 0 - masked.
1	BIOMIM	Bit Oriented Message Interrupt Mask. When unmasked an interrupt is initiated when a pattern 11111110xxxxx0 has been received on the FDL that is different from the last message. The new message must persist for 8 out the last 10 message positions to be accepted as a valid new message. If 1- unmasked, 0 - masked.
0	SIGIM	signaling Interrupt Mask. When unmasked an interrupt will be initiated when a change of state (optionally debounced - see DBEn in the Data Link, signaling Control Word page 1 address 12H) is detected in the signaling bits (AB or ABCD) pattern. If 1 - unmasked, 0 - masked.

Table 34 - Interrupt Mask Word Three (T1)

(Page 1, Address 1EH)

Bit	Name	Functional Description
7	NRZ	NRZ Format Selection. Only used in the digital framer only mode (LIU is disabled). A one sets the MT9076 to accept a unipolar NRZ format input stream on RxA as the line input, and to transmit a unipolar NRZ format stream on TxB. A zero causes the MT9076 to accept a complementary pair of dual rail inputs on RxA/RxB and to transmit a complementary pair of dual rail outputs on TxA/TxB.
6	---	Reserved. Set this low for normal operation.
5	Res	Resistor. Set this bit high to connect a 104 ohm internal resistor between RTIP and RRING. This is activated where an external 20.8 ohm terminating resistor is in use on a T1 line.
4 - 3	RxA1-0	Automatic Receive Equalizer Control. These bits should be programmed according to the table below: 00 Equalization will be activated using the control bits RxEQ2-0. 11 The receive equalizer is turned on and will compensate for loop length automatically. The control bits RxEQ2-0 will be ignored. 01, 10 Reserved for factory purposes.
2 - 0	RxEQ2-0	Receive Equalization Select. Setting these pins forces a level of equalization of the incoming line data. RES2 RES1 RES0 Receive Equalization 0 0 0 none 0 0 1 8 dB 0 1 0 16 dB 0 1 1 24 dB 1 0 0 32 dB 1 0 1 40 dB 1 1 0 48 dB 1 1 1 reserved These settings have no effect if either of RxA1 and RxA0 are set to one.

Table 35 - LIU Receiver Word (T1)

(Page 1, Address 1FH)

20.1.2 Master Control 2 (Page 02H) (T1)

Address (A₄A₃A₂A₁A₀)	Register	Names
10H (Table 37)	Configuration Control Word	T1/E1, TxEN, $\overline{\text{LIUEn}}$, ELOS, Tx8KEN, ADSEQ
11H (Table 38)	LIU Tx Word	CPL, TxLB2-0
12H	Reserved	Set all bits to zero for normal operation.
13H (Table 39)	Jitter Attenuator Control Word	JFC, JFD2-JFD0, JACL
14H	Reserved	Set all bits to zero for normal operation.
15H	Reserved	Set all bits to zero for normal operation.
16H (Table 40)	Equalizer High Threshold	EHT7-0
17H (Table 41)	Equalizer Low Threshold	ELT7-0
18H (Table 42)	Serial Config. Word	IMA, T1DM, G.802, 8Men, 8MTS1-0
19H (Table 43)	HDLC0 Select	En, $\overline{\text{FDLSEL}}$, CH4-0
1AH (Table 44)	HDLC1 Select	En, CH4-0
1BH (Table 45)	HDLC2 Select	En, CH4-0
1CH (Table 46)	Custom Pulse Word 1	CP6-0
1DH (Table 47)	Custom Pulse Word 2	CP6-0
1EH (Table 48)	Custom Pulse Word 3	CP6-0
1FH (Table 49)	Custom Pulse Word 4	CP6-0

Table 36 - Master Control 2 (Page 02H) (T1)

Bit	Name	Functional Description
7	T1/E1	T1/E1 mode selection. when this bit is zero, the device is in T1 mode. When set high, the device is in E1 mode.
6	--	Reserved. Must be kept at 0 for normal operation.
5	TxEN	Transmit Enable. Setting this bit low turns off the TTIP and TRING output line drivers. Setting this bit high enables them.
4	LIUEn	LIU Enable. Setting this bit low enables the internal LIU front-end. Setting this pin high disables the LIU. Digital inputs RXA and RXB are sampled by the rising edge of E1.5i (Exclk) to strobe in the received line data. Digital transmit data is clocked out of pins TXA and TXB with the rising edge of Exclk
3	ELOS	ELOS Enable. Set this bit low to set the analog loss of signal threshold to 40 dB below nominal. Set this bit high to set the analog loss of signal threshold to 20 dB below nominal.
2	Tx8KEN	Transmit 8 KHz Enable. If one, the pin $\overline{\text{RxMF}}/\text{TxFP}$ transmits a positive 8 KHz frame pulse synchronous with the serial data stream transmit on TXA/TXB. If zero, the pin $\overline{\text{RxMF}}/\text{TxFP}$ transmits a negative frame pulse synchronous with the multiframe boundary of data coming out of DSTo.
1	ADSEQ	Digital Milliwatt or Digital Test Sequence. If one, the A law digital milliwatt analog test sequence will be selected for those channels with per time slot control bits TTST, RRST set. If zero, a PRBS generator / detector will be connected to channels with TTST, RRST respectively.
0	--	Reserved. Must be kept at 0 for normal operation.

Table 37 - Configuration Control Word

(Page 2, Address 10H) (T1)

Bit	Name	Functional Description																																				
7-5	--	Reserved. Must be kept at 0 for normal operation.																																				
4	--	Reserved. Set low for normal operation.																																				
3	CPL	Custom Pulse Level. Setting this bit low enables the internal ROM values in generating the transmit pulses. The ROM is coded for different line terminations or build out, as specified in the LIU Control word. Setting this pin high disables the pre-programmed pulse templates. Each of the 4 phases that generate a mark derive their D/A coefficients from the values programmed in the CPW registers.																																				
2-0	TXLB2-0	<p>Transmit Line Build Out 2 - 0. Setting these bits shapes the transmit pulse as detailed in the table below:</p> <table border="1"> <thead> <tr> <th>TX22</th> <th>TXL1</th> <th>TXL0</th> <th>Line Build Out</th> </tr> </thead> <tbody> <tr> <td>0</td> <td>0</td> <td>0</td> <td>0 to 133 feet/ 0 dB</td> </tr> <tr> <td>0</td> <td>0</td> <td>1</td> <td>133 to 266 feet</td> </tr> <tr> <td>0</td> <td>1</td> <td>0</td> <td>266 to 399 feet</td> </tr> <tr> <td>0</td> <td>1</td> <td>1</td> <td>399 to 533 feet</td> </tr> <tr> <td>1</td> <td>0</td> <td>0</td> <td>533 to 655 feet</td> </tr> <tr> <td>1</td> <td>0</td> <td>1</td> <td>-7.5 dB</td> </tr> <tr> <td>1</td> <td>1</td> <td>0</td> <td>-15 dB</td> </tr> <tr> <td>1</td> <td>1</td> <td>1</td> <td>-22.5 dB</td> </tr> </tbody> </table> <p>After reset these bits are zero.</p>	TX22	TXL1	TXL0	Line Build Out	0	0	0	0 to 133 feet/ 0 dB	0	0	1	133 to 266 feet	0	1	0	266 to 399 feet	0	1	1	399 to 533 feet	1	0	0	533 to 655 feet	1	0	1	-7.5 dB	1	1	0	-15 dB	1	1	1	-22.5 dB
TX22	TXL1	TXL0	Line Build Out																																			
0	0	0	0 to 133 feet/ 0 dB																																			
0	0	1	133 to 266 feet																																			
0	1	0	266 to 399 feet																																			
0	1	1	399 to 533 feet																																			
1	0	0	533 to 655 feet																																			
1	0	1	-7.5 dB																																			
1	1	0	-15 dB																																			
1	1	1	-22.5 dB																																			

**Table 38 - LIU Tx Word
(Page 2, Address 11H) (T1)**

Bit	Name	Functional Description																																				
7	---	Unused.																																				
6	JFC	Jitter Attenuator FIFO Centre. When this bit is toggled the read pointer on the jitter attenuator shall be centered. During this centering the jitter on the JA outputs is increased by 0.0625 U.I. This feature is only available when IMA Mode is activated.																																				
5 - 3	JFD2-JFD0	<p>Jitter Attenuator FIFO Depth Control Bits. These bits determine the depths of the jitter attenuator FIFO as shown below:</p> <table border="1"> <thead> <tr> <th>JFD2</th> <th>JFD1</th> <th>JFD0</th> <th>Depth</th> </tr> </thead> <tbody> <tr> <td>0</td> <td>0</td> <td>0</td> <td>16</td> </tr> <tr> <td>0</td> <td>0</td> <td>1</td> <td>32</td> </tr> <tr> <td>0</td> <td>1</td> <td>0</td> <td>48</td> </tr> <tr> <td>0</td> <td>1</td> <td>1</td> <td>64</td> </tr> <tr> <td>1</td> <td>0</td> <td>0</td> <td>80</td> </tr> <tr> <td>1</td> <td>0</td> <td>1</td> <td>96</td> </tr> <tr> <td>1</td> <td>1</td> <td>0</td> <td>112</td> </tr> <tr> <td>1</td> <td>1</td> <td>1</td> <td>128</td> </tr> </tbody> </table> <p>This feature is only available when IMA Mode is activated.</p>	JFD2	JFD1	JFD0	Depth	0	0	0	16	0	0	1	32	0	1	0	48	0	1	1	64	1	0	0	80	1	0	1	96	1	1	0	112	1	1	1	128
JFD2	JFD1	JFD0	Depth																																			
0	0	0	16																																			
0	0	1	32																																			
0	1	0	48																																			
0	1	1	64																																			
1	0	0	80																																			
1	0	1	96																																			
1	1	0	112																																			
1	1	1	128																																			
2	JACL	Jitter Attenuator FIFO Clear Bit. If one, the Jitter Attenuator, its FIFO and status are reset. The status registers will identify the FIFO as being empty. However, the actual bit values of the data in the JA FIFO will not be reset. This feature is only available when IMA Mode is activated.																																				
1 - 0	---	Unused.																																				

Table 39 - Jitter Attenuation Control Word

(Page 2, Address 13H) (T1)

Bit	Name	Functional Description
7-0	EHT7-0	Equalizer High Threshold. These bits set the highest possible binary count tolerable coming out of the equalized signal peak detector before a lower level of equalization is selected. This register is only used when A/D based automatic equalization is selected using the Rx LIU Control Word. Recommended value to program is 10111011.

Table 40 - Equalizer High Threshold

(Page 2, Address 16H) (T1)

Bit	Name	Functional Description
7-0	ELT7-0	Equalizer Low Threshold. These bits set the lowest possible binary count tolerable coming out of the equalized signal peak detector before a higher level of equalization is selected. This register is only used when A/D based automatic equalization is selected using the Rx LIU Control Word. Recommended value to program is 00110000.

Table 41 - Equalizer Low Threshold

(Page 2, Address 17H) (T1)

Bit	Name	Functional Description															
7-6	--	Reserved. Must be kept at 0 for normal operation.															
5	IMA	Inverse Mux Mode. Setting this bit high the I/O ports to allow for easy connection to the Zarlink MT90220. DSTi becomes a serial 1.544 data stream. C4b becomes a 1.544 MHz clock that clocks DSTi in on the falling edge. RXFP becomes a positive framing pulse that is high for the first bit (the framing bit) of the serial T1 stream coming from the pin DSto. This stream is clocked out on the rising edge of Exclk. Set this pin low for all other applications.															
4	--	Reserved. Must be set to 0 for normal operation.															
3	G.802	G.802. Must be kept at 0 for normal operation. Set high for ST-BUS to DSI channel mapping as per G.802.															
2	8Men	8 Mb/s Bit Rate Select. Setting this bit low enables a serial bit rate on DSTi, CSTi and DSTo, CSTo of 2.048 Mb/s. Setting this bit high enables a gapped serial bit rate of 8.192 Mb/s on DSTi, CSTi, DSTo and CSTo.															
1-0	8MTS1-0	<p>8 Mb/s Time Slot Select. These two bits select the active timeslots on the serial 8.192 Mb/s channels. During the active timeslots incoming serial data on DSTi and CSTi is clocked into the device, and data is clocked out onto DSTo and CSTo. During inactive timeslots DSTo and CSTo are tristate. For all selections every fourth 8 Mb/s timeslot is active for the first 96 timeslots (24 x 8).</p> <p>The timeslot selection (T1 mode) is as follows:</p> <table border="0"> <tr> <td>8MTS1</td> <td>8MST0</td> <td>Active timeslots</td> </tr> <tr> <td>0</td> <td>0</td> <td>0,4,8,12,16,20,24,28,32,36,40,44,48,52,56,60,64,68,72,76,80,84,88,92</td> </tr> <tr> <td>0</td> <td>1</td> <td>1,5,9,13,17,21,25,29,33,37,41,45,49,53,57,61,65,69,73,77,81,85,89,93</td> </tr> <tr> <td>1</td> <td>0</td> <td>2,6,10,14,18,22,26,30,34,38,42,46,50,54,58,62,66,70,74,78,82,86,90,94</td> </tr> <tr> <td>1</td> <td>1</td> <td>3,7,11,15,19,23,27,31,35,39,43,47,51,55,59,63,67,71,75,79,83,87,91,95</td> </tr> </table>	8MTS1	8MST0	Active timeslots	0	0	0,4,8,12,16,20,24,28,32,36,40,44,48,52,56,60,64,68,72,76,80,84,88,92	0	1	1,5,9,13,17,21,25,29,33,37,41,45,49,53,57,61,65,69,73,77,81,85,89,93	1	0	2,6,10,14,18,22,26,30,34,38,42,46,50,54,58,62,66,70,74,78,82,86,90,94	1	1	3,7,11,15,19,23,27,31,35,39,43,47,51,55,59,63,67,71,75,79,83,87,91,95
8MTS1	8MST0	Active timeslots															
0	0	0,4,8,12,16,20,24,28,32,36,40,44,48,52,56,60,64,68,72,76,80,84,88,92															
0	1	1,5,9,13,17,21,25,29,33,37,41,45,49,53,57,61,65,69,73,77,81,85,89,93															
1	0	2,6,10,14,18,22,26,30,34,38,42,46,50,54,58,62,66,70,74,78,82,86,90,94															
1	1	3,7,11,15,19,23,27,31,35,39,43,47,51,55,59,63,67,71,75,79,83,87,91,95															

Table 42 - Serial Config. Word

(Page 2, Address 18H) (T1)

Bit	Name	Functional Description
7	En	Enable. Set high to attach the HDLC0 controller to the channel specified below. Set low to disconnect the HDLC0.
6	FDSLSEL	Facility Data Link Select. Set this bit to 0 to attach HDLC0 to the 4 kb/s facility data link. Set this bit to 1 to attach HDLC0 to a payload timeslot.
5	--	Reserved. Must be kept at 0 for normal operation.
4-0	CH4-0	Channel 4-0. This 5 bit number specifies the channel time HDLC0 will be attached to if enabled. Channel 0 is the first channel in the frame. Channel 23 is the last channel available in a T1 frame. If enabled in a channel, HDLC data will be substituted for data from DSTi on the transmit side. Receive data is extracted from the incoming line data before the elastic buffer.

Table 43 - HDLC0 Select

(Page 2, Address 19H) (T1)

Bit	Name	Functional Description
7	En	Enable. Set high to attach the HDLC1 controller to the channel specified below. Set low to disconnect the HDLC1.
6-5	--	Reserved. Must be kept at 0 for normal operation.
4-0	CH4-0	Channel 4-0. This 5 bit number specifies the channel time HDLC1 will be attached to if enabled. Channel 0 is the first channel in the frame. Channel 23 is the last channel available in a T1 frame. If enabled in a channel, HDLC data will be substituted for data from DSTi on the transmit side. Receive data is extracted from the incoming line data before the elastic buffer.

Table 44 - HDLC1 Select
(Page 2, Address 1AH) (T1)

Bit	Name	Functional Description
7	En	Enable. Set high to attach the HDLC2 controller to the channel specified below. Set low to disconnect the HDLC2.
6-5	--	Reserved. Must be kept at 0 for normal operation.
4-0	CH4-0	Channel 4-0. This 5 bit number specifies the channel time HDLC2 will be attached to if enabled. Channel 0 is the first channel in the frame. Channel 23 is the last channel available in a T1 frame. If enabled in a channel, HDLC data will be substituted for data from DSTi on the transmit side. Receive data is extracted from the incoming line data before the elastic buffer.

Table 45 - HDLC2 Select
(Page 2, Address 1BH) (T1)

Bit	Name	Functional Description
7	--	Reserved. Must be kept at 0 for normal operation.
6-0	CP6-0	Custom Pulse. These bits provide the capability for programming the magnitude setting for the TTIP/TRING line driver A/D converter during the first phase of a mark. The greater the binary number loaded into the register, the greater the amplitude driven out. This feature is enabled when the control bit 3 - CPL of the Custom Tx Pulse Enable Register - address 11H of Page 2 is set high.

Table 46 - Custom Pulse Word 1
(Page 2, Address 1CH) (T1)

Bit	Name	Functional Description
7	-	Reserved. Must be kept at 0 for normal operation.
6-0	CP6-0	Custom Pulse. These bits provide the capability for programming the magnitude setting for the TTIP/TRING line driver A/D converter during the second phase of a mark. The greater the binary number loaded into the register, the greater the amplitude driven out. This feature is enabled when the control bit 3 - CPL of the Custom Tx Pulse Enable Register - address 11H of Page 2 is set high.

Table 47 - Custom Pulse Word 2**(Page 2, Address 1DH) (T1)**

Bit	Name	Functional Description
7	--	Reserved. Must be kept at 0 for normal operation.
6-0	CP6-0	Custom Pulse. These bits provide the capability for programming the magnitude setting for the TTIP/TRING line driver A/D converter during the third phase of a mark. The greater the binary number loaded into the register, the greater the amplitude driven out. This feature is enabled when the control bit 3 - CPL of the Custom Tx Pulse Enable Register - address 11H of Page 2 is set high.

Table 48 - Custom Pulse Word 3**(Page 2, Address 1EH) (T1)**

Bit	Name	Functional Description
7	--	Reserved. Must be kept at 0 for normal operation.
6-0	CP6-0	Custom Pulse. These bits provide the capability for programming the magnitude setting for the TTIP/TRING line driver A/D converter during the fourth phase of a mark. The greater the binary number loaded into the register, the greater the amplitude driven out. This feature is enabled when the control bit 3 - CPL of the Custom Tx Pulse Enable Register - address 11H of Page 2 is set high.

CP6-0 Breakdown

CP[6]	Sign bit (0=neg, 1=pos) (only necessary for T1)
CP[5:0]	Magnitude in binary (pulse amplitude = 0.1 * CP[5:0]V)

Table 49 - Custom Pulse Word 4**(Page 2, Address 1FH) (T1)**

20.1.3 Master Status 1 (Page03H) (T1)

Address (A₄A₃A₂A₁A₀)	Register	Function
10H (Table 51)	Synchronization Status Word	TFSYNC, MFSYNC, SE, LOS
11H (Table 52)	Alarm Status Word	D4YALM, D4Y48, SECYEL, ESFYEL, BLUE, PDV, LLED, LLDD
12H (Table 53)	Timer Status Word	1SEC, 2SEC, 5SEC
13H (Table 54)	Most Significant Phase Status Word	RSLIP, RSLPD, RxFRM, RxFT, RxSBD2-0
14H (Table 55)	Least Significant Phase Status Word	RxTS4-0, RxBC2-0
15H (Table 56)	Receive Bit Oriented Message	RxBOM7-0
16H (Table 57)	Receive Signal Status Word	LLOS
17H (Table 58)	MSB Transmit Slip Buffer	TSLIP, TSLPD, TxSBMSB
18H (Table 59)	Transmit Slip Buffer Delay	TxTS4-0, TxBC2-0
19H	---	Unused.
1AH	---	Unused.
1BH	---	Unused.
1CH	---	Reserved.
1DH (Table 60)	Analog Peak Detect	AP7-0
1EH	---	Reserved
1FH (Table 61)	Identification Word	Internally set to 01111000

Table 50 - Master Status 1 (Page 3) (T1)

Bit	Name	Functional Description
7	TFSYNC	Terminal Frame Synchronization. Indicates the Terminal Frame Synchronization status (1 - loss; 0 - acquired). For ESF links terminal frame synchronization and multiframe synchronization are synonymous.
6	MFSYNC	Multiframe Synchronization. Indicates the Multiframe Synchronization status (1 - loss; 0 -acquired). For ESF links multiframe synchronization and terminal frame synchronization are synonymous.
5	SE	Severely Errored Frame. This bit toggles when 2 of the last 6 received framing bits are in error. The framing bits monitored are the ESF framing bits for ESF links, the Ft bits for SLC-96 links and a combination of Ft and Fs bits for D4 links (See Framing Mode Selection Word - page 1 address 10H).
4	LOS	Digital Loss Of Signal. This bit goes high after the detection of a string of consecutive zeros. It returns low when the incoming pulse density exceeds 12.5% over a 250 ms period. The threshold for this condition is set by the control bit L32Z. If L32Z is set high the threshold is 32 successive zeros. If L32Z is set low the threshold is 192 successive zeros.
3 - 0	---	Unused.

**Table 51 - Synchronization Status Word
(Page 3, Address 10H) (T1)**

Bit	Name	Functional Description
7	D4YALM	D4 Yellow Alarm. This bit is set if bit position 2 of virtually every DS0 channel is a zero for a period of 600 milliseconds. The alarm is tolerant of errors by permitting up to 16 ones in a 48 millisecond integration period. The alarm clears in 200 milliseconds after being removed from the line.
6	D4Y48	D4 Yellow Alarm - 48 millisecond sample. This bit is set if bit position 2 of virtually every DS0 channel is a zero for a period of 48 milliseconds. The alarm is tolerant of errors by permitting up to 16 ones in the integration period. This bit is updated every 48 milliseconds.
5	SECYEL	Secondary D4 Yellow Alarm. This bit is set if 2 consecutive '1's are received in the Sbit position of the 12th frame of the D4 superframe.
4	ESFYEL	ESF Yellow Alarm. This bit is set if the ESF yellow alarm 0000000011111111 is receive in seven or more codewords out of ten.
3	BLUE	Blue Alarm. This bit is set if less than 6 zeros are received in a 3 millisecond window.
2	PDV	Pulse Density Violation. This bit toggles if the receive data fails to meet ones density requirements. If RXB8ZS is set high it will toggle upon detection of 8 zeros. If RXB8ZS is set low it will toggle upon detection of 16 consecutive zeros on the line data, or if there are less than N ones in a window of 8(N+1) bits - where N = 1 to 23.
1	LLED	Line Loopback Enable Detect. This bit will be set when a framed or unframed repeating pattern of 00001 has been detected during a 48 millisecond interval. Up to fifteen errors are permitted per integration period.
0	LLDD	Line Loopback Disable Detect. This bit will be set when a framed or unframed repeating pattern of 001 has been detected during a 48 millisecond interval. Up to fifteen errors are permitted per integration period.

Table 52 - Alarm Status Word

(Page 3, Address 11H) (T1)

Bit	Name	Functional Description
7	1SEC	One Second Timer Status. This bit changes state once every 0.5 seconds.
6	2SEC	Two Second Timer Status. This bit changes state once every second and is synchronous with the 1SEC timer.
5	5SEC	Five Second Timer Status. This bit changes state once every 2.5 seconds and is synchronous with the 1SEC timer.
4-0	---	Unused.

Table 53 - Timer Status Word

(Page 3, Address 12H) (T1)

Bit	Name	Functional Description
7	RSLIP	Receive Slip. A change of state (i.e., 1-to-0 or 0-to-1) indicates that a receive controlled frame slip has occurred.
6	RSLPD	Receive Slip Direction. If one, indicates that the last received frame slip resulted in a repeated frame, i.e., the system clock (C4b) is faster than network clock (E2o). If zero, indicates that the last received frame slip resulted in a lost frame, i.e., system clock slower than network clock. Updated on an RSLIP occurrence basis.
5	RxFRM	Receive Frame Delay. The most significant bit of the Receive Slip Buffer Phase Status Word. If one, the delay through the receive elastic buffer is greater than one frame in length; if zero, the delay through the receive elastic buffer is less than one frame in length.
4	---	Unused.
3	RxFT	Receive Frame Toggle. This bit toggles on the falling edge of RxTS4. It is a Wink pulse.
2-0	RxSBD2-0	Receive Sub Bit Delay. The three least significant bits of the Receive Slip Buffer Phase Status Word. They indicate the clock, half clock and one eighth clock cycle depth of the phase status word sample point (bits 2, 1,0 respectively).

Table 54 - Most Significant Phase Status Word

(Page 3, Address 13H) (T1)

Bit	Name	Functional Description
7 - 3	RxTS4 - 0	Receive Time Slot. A five bit counter that indicates the number of time slots between the receive elastic buffer internal write frame boundary and the ST-BUS read frame boundary. The count is updated every 250 uS.
2 - 0	RxBC2 - 0	Receive Bit Count. A three bit counter that indicates the number of STBUS bit times there are between the receive elastic buffer internal write frame boundary and the ST-BUS read frame boundary. The count is updated every 250 uS.

Table 55 - Least Significant Phase Status Word

(Page 3, Address 14H) (T1)

Bit	Name	Functional Description
7 - 0	RxBOM7 - 0	Received Bit Oriented Message. This register contains the eight least significant bits of the ESF bit oriented message codeword. The contents of this register is updated when a new bit - oriented message codeword has been detected in 8 out of the last ten codeword positions.

Table 56 - Receive Bit Oriented Message

(Page 3, Address 15H) (T1)

Bit	Name	Functional Description
7	LLOS	LIU Loss of Signal indication. This bit will be high when the received signal is less than 40 dB below the nominal value for a period of at least 1 msec. This bit will be low for normal operation.
6-0	---	Unused.

Table 57 - Receive Signal Status Word

(Page 3, Address 16H) (T1)

Bit	Name	Functional Description
7	TSLIP	Transmit Slip. A change of state (i.e., 1-to-0 or 0-to-1) indicates that a transmit controlled frame slip has occurred.
6	TSLPD	Transmit Slip Direction. If one, indicates that the last transmit frame slip resulted in a repeated frame, i.e., the internally generated 1.544 MHz. transmit clock is faster than the system clock (C4b). If zero, indicates that the last transmit frame slip resulted in a lost frame, i.e., the internally generated 1.544 MHz. transmit clock is slower than network clock. Updated on an TSLIP occurrence basis.
5	TxSBMSB	Transmit Slip Buffer MSB. The most significant bit of the phase status word. If one, the delay through the transmit elastic buffer is greater than one frame in length; if zero, the delay through the receive elastic buffer is less than one frame in length. This bit is reset whenever page 1 address 17H - Transmit Slip Buffer Delay - is written to.
4 - 0	---	Unused.

Table 58 - MSB Transmit Slip Buffer

(Page 3, Address 17H) (T1)

Bit	Name	Functional Description
7 - 3	TxTTS4 - 0	Transmit Time Slot. A five bit counter that indicates the number of STBUS time slots between the transmit elastic buffer STBUS write frame boundary and the internal transmit read frame boundary. The count is updated every 250 uS.
2 - 0	TxBC2 - 0	Transmit Bit Count. A three bit counter that indicates the number of STBUS bit times there are between the transmit elastic buffer STBUS write frame boundary and the internal read frame boundary. The count is updated every 250 uS.

Table 59 - Transmit Slip Buffer Delay

(Page 3, Address 18H) (T1)

Bit	Name	Functional Description
7 - 0	AP7 - 0	Analog Peak. This status register gives the output value of an 8 bit A/D converter connected to a peak detector on RTIP/RRING.

Table 60 - Analog Peak Detect

(Page 3, Address 1DH) (T1)

Bit	Name	Functional Description
7-0	ID7-0	ID Number. Contains device code 01111000

Table 61 - Identification Word
(Page 3, Address 1FH) (T1)

20.1.4 Master Status 2 (Page 04H) (T1)

Address (A ₄ A ₃ A ₂ A ₁ A ₀)	Register	Function
10H (Table 63)	PRBS Error Counter	PS7-0
11H (Table 64)	CRC Multiframe counter for PRBS	PSM7-0
12H (Table 65)	Alarm Reporting Latch	D4YALML, D4Y48L, SECYELL, ESFYELL, BLUEL, PDVL, LLEDL, LLDDL
13H (Table 66)	Framing Bit Counter	FC7-0
14H (Table 67)	Out of Frame / Change of Frame Alignment Counters	OOF3-0/COFA3-0
15H (Table 68)	Multiframes Out of Sync Counter	MFOOF7-0
16H (Table 69)	Most Significant Line Code Violation Error Counter	LCV15 - LCV8
17H (Table 70)	Least Significant Line Code Violation Error Counter	LCV7 - LCV0
18H (Table 71)	CRC- 6 Error Counter (Address 18H)	CC15-CC8
19H (Table 72)	CRC- 6 Error Counter (Address 19H)	CC7 - CC0
1AH		Unused.
1BH (Table 73)	Interrupt Word Zero	TFSYNI, MFSYNI, BIOMTI, AISI, LOSI, SEI, TxSLPI, RxSLPI
1CH (Table 74)	Interrupt Word One	FEI, CRCI, YELI, COFAI, LCVI, PRBSI, PDVI
1DH (Table 75)	Interrupt Word Two	FEO, CRCO, OOFO, COFAO, LCVO, PRBSO, PRBSMFO, MFOOFO
1EH (Table 76)	Interrupt Word Three	HDLC0I, HDLC1I, HDLC2I, LCDI, 1SECI, 5SECI, BIOMI, SIGI
1FH (Table 77)	Overflow Reporting Latch	FEOL, CRCOL, OOFOL, COFAOL, LCVOL, PRBSOL, PRBSMFO, MFOOFOL

Table 62 - Master Status 2 (Page 4) (T1)

Bit	Name	Functional Description
7 - 0	PS7-0	This counter is incremented for each PRBS error detected on any of the receive channels connected to the PRBS error detector.

Table 63 - PRBS Error Counter

(Page 4, Address 10H) (T1)

Bit	Name	Functional Description
7 - 0	PSM7-0	This counter is incremented for each received CRC multiframe. It is cleared when the PRBS Error Counter is written to.

Table 64 - CRC Multiframe Counter for PRBS

(Page 4, Address 11H) (T1)

Bit	Name	Functional Description
7	D4YALML	D4 Yellow Alarm Latch. This bit is set if a D4 yellow alarm is detected within a 600 millisecond integration period. It is cleared after a read.
6	D4Y48L	D4 Yellow Alarm (48 milliseconds) Latch. This bit is set if a D4 yellow alarm is detected within a 48 millisecond integration period. It is cleared after a read.
5	SECYELL	Secondary D4 Yellow Alarm Latch. This bit is set if an alternate D4 (S bit in 12 the frame) is detected. It is cleared after a read.
4	ESFYELL	ESF Yellow Alarm Latch. This bit is set upon receipt of a ESF yellow alarm. It is cleared after a read.
3	BLUEL	Blue Alarm Latch. This bit is set upon receipt of a blue alarm. It is cleared after a read.
2	PDVL	Pulse Density Violation Latch. This bit is set upon receipt of a pulse density violation. It is cleared after a read.
1	LLEDL	Line Loopback Enable Detect Latch. This bit is set upon receipt of a line loopback enable code. It is cleared after a read.
0	LLDDL	Line Loopback Disable Detect Latch. This bit is set upon receipt of a line loopback disable code. It is cleared after a read.

Table 65 - Alarm Reporting Latch

(Page 4, Address 12H) (T1)

Bit	Name	Functional Description
7 - 0	FC7 - 0	Framing Bit Counter. This eight bit counter will be incremented for each error in the received framing pattern. In ESF mode the ESF framing bits are monitored. In D4 mode Fs bits may be monitored as well as Ft bits. See - Section 15.5 Framing Bit Counter. The count is only active if the 3VJET is in synchronization.

Table 66 - Framing Bit Counter

(Page 4, Address 13H) (T1)

Bit	Name	Functional Description
7 - 4	OOF3 - 0	Out Of Frame Counter. This four bit counter is incremented with every loss of receive frame synchronization.
3 - 0	COFA3 - 0	Change of Frame Alignment Counter. This four bit counter is incremented if a resynchronization is done which results in a shift in the frame alignment position.

Table 67 - Out Of Frame / Change of Frame Alignment Counter

(Page 4, Address 14H) (T1)

Bit	Name	Functional Description
7 - 0	MFOOF7 - 0	Multiframes Out of Synchronization Counter. This eight bit counter will be incremented once for every multiframe (1.5 milliseconds in D4 mode, 3 milliseconds in ESF mode) in which basic frame synchronization is lost.

Table 68 - Multiframes Out of Sync Counter

(Page 4, Address 15H) (T1)

Bit	Name	Functional Description
7 - 0	LCV15 - 8	Most Significant Bits of the LCV Counter. The most significant eight bits of a 16 bit counter that is incremented once for every line code violation error received. A line code violation is defined as a bipolar violation that is not a part of B8ZS encoding when the control bit EXZ is set low. A line code violation includes both bipolar violations and excess zeros when EXZ is set high.

Table 69 - Most Significant Bits of the LCV Counter

(Page 4, Address 16H) (T1)

Bit	Name	Functional Description
7 - 0	LCV7 - 0	Least Significant Bits of the LCV Counter. The least significant eight bits of a 16 bit counter that is incremented once for every line code violation error received. A line code violation is defined as a bipolar violation that is not a part of B8ZS encoding when the control bit EXZ is set low. A line code violation includes both bipolar violations and excess zeros when EXZ is set high.

Table 70 - Least Significant Bits of the LCV Counter

(Page 4, Address 17H) (T1)

Bit	Name	Functional Description
7 - 0	CC15 - 8	CRC-6 Error Counter Bits Fifteen to Eight. These are the most significant eight bits of the CRC-6 error counter.

Table 71 - CRC-6 Error Counter

(Page 4, Address 18H) (T1)

Bit	Name	Functional Description
7 - 0	CC7 - 0	CRC-6 Error Counter Bits Seven to Zero. These are the least significant eight bits of the CRC-6 error counter.

Table 72 - CRC-6 Error Counter

(Page 4, Address 19H) (T1)

Bit	Name	Functional Description
7	TFSYNI	Terminal Frame Synchronization Interrupt. When unmasked this interrupt bit goes high whenever a change of state of terminal frame synchronization condition exists. Reading this register clears this bit.
6	MFSYNI	Multiframe Synchronization Interrupt. When unmasked this interrupt bit goes high whenever a change of state of multiframe synchronization condition exists. Reading this register clears this bit.
5	BIOMTI	Bit Oriented Message Transition Interrupt. When unmasked, this interrupt goes high whenever a new BIOM arrives or if the current BIOM stops transmission.
4	AISI	Alarm Indication Signal Interrupt. When unmasked this interrupt bit goes high whenever a change of state of received all ones condition exists. Reading this register clears this bit.
3	LOSI	Loss of Signal Interrupt. When unmasked this interrupt bit goes high whenever a change of state of loss of signal (either analog - signal 40 dB below nominal or digital - excess consecutive 0's received) condition exists. Reading this register clears this bit.
2	SEI	Severely Errored Frame Interrupt. When unmasked this interrupt bit goes high whenever a sequence of 2 framing errors out of 6 occurs. Reading this register clears this bit.
1	TxSLPI	Transmit SLIP Interrupt. When unmasked this interrupt goes high whenever a controlled frame slip occurs in the transmit elastic buffer. Reading this register clears this bit.
0	RxSLPI	Receive SLIP Interrupt. When unmasked this interrupt bit goes high whenever a controlled frame slip occurs in the receive elastic buffer. Reading this register clears this bit.

Table 73 - Interrupt Word Zero

(Page 4, Address 1BH) (T1)

Bit	Name	Functional Description
7	FEI	Framing Bit Error Interrupt. When unmasked this interrupt bit goes high whenever an erroneous framing bit is detected (provided the circuit is in terminal frame sync). Reading this register clears this bit.
6	CRCI	CRC-6 Error Interrupt. When unmasked this interrupt bit goes high whenever a local CRC-6 error occurs. Reading this register clears this bit.
5	YELI	Yellow Alarm Interrupt. When unmasked this interrupt bit goes high upon detection of a yellow alarm. Reading this register clears this bit.
4	COFAI	Change of Frame Alignment Interrupt. When unmasked this interrupt bit goes high whenever a change of frame alignment occurs after a reframe. Reading this register clears this bit.
3	LCVI	Line Code Violation Interrupt. When unmasked this interrupt bit goes high whenever a line code violation (excluding B8ZS encoding) is encountered. Reading this register clears this bit.
2	PRBSI	Pseudo Random Bit Sequence Error Interrupt. When unmasked this interrupt bit goes high upon detection of an error with a channel selected for PRBS testing. Reading this register clears this bit.
1	PDVI	Pulse Density Violation Interrupt. When unmasked this interrupt bit goes high whenever, in the absence of B8ZS encoding, a sequence of 16 consecutive zeros is received on the line, or the incoming pulse density is less than N ones in a time frame of $8(N+1)$ where $N = 1$ to 23. In the case of B8ZS coding, the interrupt is set upon detection of 8 consecutive zeros. Reading this register clears this bit.
0	---	Unused.

Table 74 - Interrupt Word One

(Page 4, Address 1CH) (T1)

Bit	Name	Functional Description
7	FEO	Framing Bit Error Counter Overflow Interrupt. When unmasked this interrupt bit goes high whenever the framing bit error counter changes from FFH to 00H. Reading this register clears this bit.
6	CRCO	CRC-6 Error Counter Overflow Interrupt. When unmasked this interrupt bit goes high whenever the CRC-6 error counter changes from FFH to 00H. Reading this register clears this bit.
5	OOFO	Out Of Frame Counter Overflow Interrupt. When unmasked this interrupt bit goes high whenever the out of frame counter changes state from changes from FFH to 00H. Reading this register clears this bit.
4	COFAO	Change of Frame Alignment Counter Overflow Interrupt. When unmasked this interrupt bit goes high whenever the change of frame alignment counter changes from FFH to 00H. Reading this register clears this bit.
3	LCVO	Line Code Violation Counter Overflow Interrupt. When unmasked this interrupt bit goes high whenever the line code violation counter changes from FFH to 00H. Reading this register clears this bit.
2	PRBSO	Pseudo Random Bit Sequence Error Counter Overflow Interrupt. When unmasked this interrupt bit goes high whenever the PRBS error counter changes from FFH to 00H. Reading this register clears this bit.
1	PRBSMFO	Pseudo Random Bit Sequence Multiframe Counter Overflow Interrupt. When unmasked this interrupt bit goes high whenever the multiframe counter attached to the PRBS error counter overflows. FFH to 00H. 1 - unmasked, 0 - masked.
0	MFOOFO	Multiframes Out Of Sync Overflow Interrupt. When unmasked this interrupt bit goes high whenever the multiframes out of frame counter changes from FFH to 00H. Reading this register clears this bit.

Table 75 - Interrupt Word Two

(Page 4, Address 1DH) (T1)

Bit	Name	Functional Description
7	HDLC0I	HDLC0 Interrupt. Whenever an unmasked HDLC0 interrupt occurs this bit goes high. Reading this register clears this bit.
6	HDLC1I	HDLC1 Interrupt. Whenever an unmasked HDLC1 interrupt occurs this bit goes high. Reading this register clears this bit.
5	HDLC2I	HDLC2 Interrupt. Whenever an unmasked HDLC2 interrupt occurs this bit goes high. Reading this register clears this bit.
4	LCDI	Loop Code Detected Interrupt. When unmasked this interrupt bit goes high whenever either the loop up (00001) or loop down (001) code has been detected on the line for a period of 48 milliseconds. Reading this register clears this bit.
3	1SECI	One Second Status Interrupt. When unmasked this interrupt bit goes high whenever the 1SEC status bit (page 3 address 12H bit 7) goes from low to high. Reading this register clears this bit.
2	5SECI	Five Second Status Interrupt. When unmasked this interrupt bit goes high whenever the 5 SEC status bit goes from low to high. Reading this register clears this bit.
1	BIOMI	Bit Oriented Message Interrupt. When unmasked this interrupt bit goes high whenever a pattern 11111110xxxxx0 has been received on the FDL that is different from the last message. The new message must persist for 8 out the last 10 message positions to be accepted as a valid new message. Reading this register clears this bit.
0	SIGI	signaling Interrupt. When unmasked this interrupt bit goes high whenever a change of state (optionally debounced - see DBEn in the Data Link, signaling Control Word page 1 address 12H) is detected in the signaling bits (AB or ABCD) pattern. Reading this register clears this bit.

Table 76 - Interrupt Word Three

(Page 4, Address 1EH) (T1)

Bit	Name	Functional Description
7	FEOL	Framing Bit Error Counter Overflow Latch. This bit is set when the framing bit counter overflows. It is cleared after being read.
6	CRCOL	CRC-6 Error Counter Overflow Latch. This bit is set when the crc error counter overflows. It is cleared after being read.
5	OOFOL	Out Of Frame Counter Overflow Latch. This bit is set when the out of frame counter overflows. It is cleared after being read.
4	COFAOL	Change of Frame Alignment Counter Overflow Latch. This bit is set when the change of frame alignment counter overflows. It is cleared after being read.
3	LCVOL	Line Code Violation Counter Overflow Latch. This bit is set when the line code violation counter overflows. It is cleared after being read.
2	PRBSOL	Pseudo Random Bit Sequence Error Counter Overflow Latch. This bit is set when the PRBS error counter overflows. It is cleared after being read.
1	PRBSMFOL	Pseudo Random Bit Sequence Multiframe Counter Overflow Latch. This bit is set when the multiframe counter attached to the PRBS error counter overflows. It is cleared after being read.
0	MFOOFOL	Multiframes Out Of Sync Overflow Latch. This bit is set when the multiframes out of sync counter overflows. It is cleared after being read.

Table 77 - Overflow Reporting Latch

(Page 4, Address 1FH) (T1)

20.1.5 Per Channel Transmit Signalling (Pages 5 and 6) (T1)

Page 05H, addresses 10000 to 11111, and page 06H addresses 10000 to 10111 contain the Transmit signaling Control Words for DS1 channels 1 to 16 and 17 to 24 respectively. Table 78 illustrates the mapping between the addresses of these pages and the DS1 channel numbers. Control of these bits for any one channel is through the processor or controller port when the Per Time Slot Control bit RPSIG bit is high. Table 79 describes bit allocation within each of these registers.

Page 5 Address:	0	1	2	3	4	5	6	7	8	9	10	11	12	13	14	15
Equivalent DS1 channel	1	2	3	4	5	6	7	8	9	10	11	12	13	14	15	16
Page 6 Address:	0	1	2	3	4	5	6	7	8	9	10	11	12	13	14	15
Equivalent DS1 channel	17	18	19	20	21	22	23	24	x	x	x	x	x	x	x	x

Table 78 - Pages 5 and 6 Address Mapping to DS1 Channels (T1)

Bit	Name	Functional Description
7 - 4	---	Unused.
3	A(n)	Transmit signaling Bits A for Channel n. Where signaling is enabled, these bits are transmitted in bit position 8 of the 6th DS1 frame (within the 12 frame superframe structure for D4 superframes and the 24 frame structure for ESF superframes).
2	B(n)	Transmit signaling Bits B for Channel n. Where signaling is enabled, these bits are transmitted in bit position 8 of the 12th DS1 frame (within the 12 frame superframe structure for D4 superframes and the 24 frame structure for ESF superframes).
1	C(n)	Transmit signaling Bits C for Channel n. Where signaling is enabled, these bits are transmitted in bit position 8 of the 18th DS1 frame within the 24 frame structure for ESF superframes. In D4 mode these bits are unused.
0	D(n)	Transmit signaling Bits D for Channel n. Where signaling is enabled, these bits are transmitted in bit position 8 of the 24th DS1 frame within the 24 frame structure for ESF superframes. In D4 mode these bits are unused.

Table 79 - Transmit Channel Associated Signaling (T1) (Pages 5 and 6)

Serial per channel transmit signaling control through CSTi is selected when the Per Time Slot Control bit RPSIG bit is low. Table 80 describes the bit allocation within each of the 24 active ST-BUS time slots of CSTi.

Bit	Name	Functional Description
7 - 4	A(n), B(n), C(n), D(n)	Transmit signaling Bits for Channel n. When control bit MSN = 1 and RPSIG = 1 this nibble is used. For ESF links these 4 bits are transmitted on the associated DS1 channel (see Table 8) in frames 6, 12, 18 and 24. For D4 links bits A are transmit on the associated Ds1 channel of frame 6 and bits B are transmit on the associated DS1 channel of frame 12. For D4 links bits C and D are unused.
3 - 0	A(n), B(n), C(n), D(n)	Transmit signaling Bits for Channel n. When control bit MSN = 0 and RPSIG = 1 this nibble is used. For ESF links these 4 bits are transmitted on the associated DS1 channel (see Table 8) in frames 6, 12, 18 and 24. For D4 links bits A are transmit on the associated Ds1 channel of frame 6 and bits B are transmit on the associated DS1 channel of frame 12. For D4 links bits C and D are unused.

Table 80 - T1 / Transmit Channels Usage - CSTi

NOTE: This table illustrates bit mapping on the serial input stream - it does not refer to an internal register.

20.2 Per Time Slot Control Words (Pages 7 and 8) (T1)

The control functions described by Table 78 are repeated for each DS1 time slot. Page 7 addresses 10000 to 11111 correspond to DS1 time slot 1 to 16, while page 8 addresses 10000 to 10111 correspond to time slots 17 to 24. Table 81 illustrates the mapping between the addresses of these pages and the DS1 channel numbers.

Page 7 Address:	0	1	2	3	4	5	6	7	8	9	10	11	12	13	14	15
Equivalent DS1 channel	1	2	3	4	5	6	7	8	9	10	11	12	13	14	15	16

Table 81 - Pages 7 and 8 Address Mapping to DS1 Channels

Page 8 Address:	0	1	2	3	4	5	6	7	8	9	10	11	12	13	14	15
Equivalent DS1 channel	17	18	19	20	21	22	23	24	x	x	x	x	x	x	x	x

Table 81 - Pages 7 and 8 Address Mapping to DS1 Channels

Bit	Name	Functional Description
7	TXMSG	Transmit Message Mode. If high, the data contained in the Transmit Message Register (address 18H, page 1) is transmitted in the corresponding DS1 time slot. If zero, the data on DSTi is transmitted on the corresponding DS1 time slot.
6	PCI	Per Channel Inversion. When set high the data for this channel sourced from DSTi is inverted before being transmit onto the equivalent DS1 channel; the data received from the incoming DS1 channel is inverted before it emerges from DSTo.
5	RTSL	Remote Time Slot Loopback. If one, the corresponding DS1 receive time slot is looped to the corresponding DS1 transmit time slot. This received time slot will also be present on DSTo. If zero, the loopback is disabled.
4	LTSL	Local Time Slot Loopback. If one, the corresponding transmit time slot is looped to the corresponding receive time slot. This transmit time slot will also be present on the transmit DS1 stream. If zero, this loopback is disabled.
3	TTST	Transmit Test. If one, a test signal, either digital milliwatt (when control bit ADSEQ is one) or PRBS ($2^{15}-1$) (ADSEQ is zero), will be transmitted in the corresponding DS1 time slot. More than one time slot may be activated at once. If zero, the test signal will not be connected to the corresponding time slot.
2	RTST	Receive Test. If one, the corresponding DSTo timeslot will be used for testing. If control bit ADEQ is one, a digital milliwatt will be transmitted in the corresponding DSTo channel. If control bit ADSEQ is zero, the receive channel will be connected to the PRBS detector ($2^{15}-1$).
1	RPSIG	Serial Signaling Enable. If set low, the transmit signaling buffer for the equivalent DS1 channel will be sourced from the ST-BUS channel on CSTi associated with it. If set high the transmit signaling RAM must be programmed via the microport.
0	CC	Clear Channel. When set high no robbed bit signaling is inserted in the equivalent transmit DS1 channel. When set low robbed bit signaling is included in every 6th channel.

Table 82 - Per Time Slot Control Words (Pages 7 and 8) (T1)

20.2.1 Per Channel Receive Signaling (T1 and E1 mode) (Pages 9 and 0AH)

Page 09H, addresses 10000 to 11111, and page 1AH addresses 10000 to 10111 contain the Receive signaling Control Words for DS1 channels 1 to 16 and 17 to 24 respectively. Table 83 illustrates the mapping between the addresses of these pages and the DS1 channel numbers. Table 84 describes bit allocation within each of these registers.

Page 9 Address:	0	1	2	3	4	5	6	7	8	9	10	11	12	13	14	15
Equivalent DS1 channel	1	2	3	4	5	6	7	8	9	10	11	12	13	14	15	16
Page A Address:	0	1	2	3	4	5	6	7	8	9	10	11	12	13	14	15
Equivalent DS1 channel	17	18	19	20	21	22	23	24	x	x	x	x	x	x	x	x

Table 83 - Pages 9 and A Address Mapping to DS1 Channels (T1)

Bit	Name	Functional Description
7 - 4	---	Unused.
3	A(n)	Receive signaling Bits A for Channel n. These bits are extracted from bit position 8 of every channel in received frame 6 (within the 12 frame superframe structure for D4 superframes and the 24 frame structure for ESF superframes). The bits may be debounced for 6 to 9 milliseconds where control bit DBNCE is set high.
2	B(n)	Receive signaling Bits B for Channel n. These bits are extracted from bit position 8 of every channel in received frame 12 (within the 12 frame superframe structure for D4 superframes and the 24 frame structure for ESF superframes). The bits may be debounced for 6 to 9 milliseconds where control bit DBNCE is set high.
1	C(n)	Receive signaling Bits C for Channel n. These bits are extracted from bit position 8 of every channel in received frame 18 within the 24 frame structure for ESF superframes. The bits reported may be debounced for 6 to 9 milliseconds where control bit DBNCE is set high. In D4 mode these bits are unused.
0	D(n)	Receive signaling Bits D for Channel n. These bits are extracted from bit position 8 of every channel in received frame 24 within the 24 frame structure for ESF superframes. The bits reported may be debounced for 6 to 9 milliseconds where control bit DBNCE is set high. In D4 mode these bits are unused.

Table 84 - Receive Channel Associated Signaling (Pages 9 and A) (T1)

20.3 E1 Mode

20.3.1 Master Control 1 (Page 01H) (E1)

Address (A ₄ A ₃ A ₂ A ₁ A ₀)	Register	Function
10H (Table 86)	Mode Selection Control Word	ASEL, CRCM, $\overline{\text{AUTC}}$, $\overline{\text{ARAI}}$, $\overline{\text{AUTY}}$, CSYN, REFRM, MFRF
11H (Table 87)	Transmit Alarm Control Word	TE, TAIS16, $\overline{\text{TxAO}}$, Einv
12H (Table 88)	TS0 Control Word	EXZ, SaBorNi, RxTRSP, TxTRSP, TIU1, TIU0
13H (Table 89)	Transmit Multiframe Alignment Signal	TMA1-4, X1, Y, X2, X3
14H (Table 90)	Interrupt and signaling Control Word	DSToEn, CSToEn, TxCCS, DBNCE, MSN
15H (Table 91)	Coding and Loopback Control Word	RxHDB3, MLBK, TxHDB3, DLBK, RLBK, SLBK, PLBK
16H (Table 92)	Non Frame Alignment Control Word	TALM, TNU4-8
17H (Table 93)	Multiframe and Data Link Selection	MFSEL, NBTB, Sa4-Sa8
18H (Table 94)	Transmit Message Word	TXM7-0
19H (Table 95)	Error Insertion Word	BPVE, CRCE, FASE, NFSE, LOSE, PERR, L32Z, LOS/LOF
1AH (Table 96)	Signaling Control Word	RST, SPND, INTA, CNTCLR, SAMPLE, OOFF
1BH (Table 97)	Interrupt Mask Word Zero	SYNIM, MFSYIM, CSYNIM, AISIM, LOSIM, CEFIM, YMI, SLPIM
1CH (Table 98)	Interrupt Mask Word One	FERIM, CRCIM, EBIM, AIS16IM, LCVIM, PRBSIM, AUXPIM & RAIM
1DH (Table 99)	Interrupt Mask Word Two	FEOM, CRCOM, EOM, LCVOM, PRBSOM, PRBSMFOM, SaIM
1EH (Table 100)	Interrupt Mask Word Three	HDLC0IM, HDLC1IM, HDLC2IM, JAIM, 1SECIM, 5SECIM, RCRIM, SIGIM
1FH (Table 101)	LIU Receiver Word	NRZ, RxA1-0, RxEQ2-0

Table 85 - Master Control 1 (Page 1) (E1)

Bit	Name	Functional Description
7	ASEL	AIS Select. This bit selects the criteria on which the detection of a valid Alarm Indication Signal (AIS) is based. If zero, the criteria is less than three zeros in a two frame period (512 bits). If one, the criteria is less than three zeros in each of two consecutive double-frame periods (512 bits per double frame).
6	CRCM	CRC-4 Modification. If one activates the CRC-4 remainder modification function when the device is in transparent mode. The received CRC-4 remainder is modified to reflect only the changes in the transmit DL. If zero, time slot zero data from DSTi will not be modified in transparent mode.
5	$\overline{\text{AUTC}}$	Automatic CRC-interworking. If zero, automatic CRC-interworking is activated. If one it is deactivated. See Framing Algorithm for a detailed description.
4	$\overline{\text{ARAI}}$	Automatic Remote Alarm Indication. if zero, the Remote Alarm Indication bit (the A bit) will function automatically. That is, RAI=1 when basic synchronization has been acquired. And, RAI=0 when basic synchronization has not been acquired. if one, the remote alarm indication bit is controlled through the TALM bit of the transmit Non-Frame Alignment Control Word.
3	$\overline{\text{AUTY}}$	Automatic Y-Bit Operation. If zero, the Y-bit of the transmit multiframe alignment signal will report the multiframe alignment status to the far end i.e., zero - multiframe alignment acquired, one - lost. If one, the Y-bit is under the manual control of the Transmit Multiframe Alignment Control Word.
2	CSYN	CRC-4 Synchronization. If zero, basic CRC-4 synchronization processing is activated, and the TIU0 Bit and the TIU1 bit programming will be overwritten. If one, CRC-4 synchronization is disabled, the first bits of channel 0 are used as international use bits and are programmed by the TIU0 and TIU1.
1	REFRM	Reframe. If one for at least one frame, and then cleared, the device will initiate a search for a new basic frame position. Reframing function is activated on the one to zero transition of the REFRM bit.
0	MFRF	Multiframe Reframe. If one, for at least one frame, and then cleared the 3VJET will initiate a search for a new signaling multiframe position. Reframing function is activated on the one to zero transition of the MFRM bit.

Table 86 - Mode Selection Control Word (E1)

(Page 1, Address 10H)

Bit	Name	Functional Description
7	--	Reserved. Must be kept at 0 for normal operation.
6	TE	Transmit E bits. When zero and CRC-4 synchronization is achieved, the E-bits transmit the received CRC-4 comparison results to the distant end of the link, as per G.703. That is, when zero and CRC-4 synchronization is lost, the transmit E-bits will be zero. If one, and CRC-4 synchronization is lost the transmit E-bits will be one.
5	TAIS16	Transmit AIS Time Slot 16. If one, an all ones signal is transmitted in time slot 16. If zero, time slot functions normally.
4	$\overline{\text{TxAO}}$	Transmit All Ones. When low, this control bit forces a framed or unframed (depending on the state of Transmit Alarm Control bit 0) all ones to be transmit at TTIP and TRING.
3	Einv	Ebit Error Inversion. When zero, received Ebits set to zero are counted in the Ebit error counter and interrupt generator. When one, Ebits set to one are counted in the Ebit error counter and interrupt generator.
2-0	---	Unused.

Table 87 - Transmit Alarm Control Word (E1)

(Page 1, Address 11H)

Bit	Name	Functional Description
7	---	Unused.
6	---	Unused.
5	EXZ	Excess Zeros. Setting this bit causes each occurrence of received excess zeros to increment the Line Code Violation Counter. Excess zeros are defined as 4 or more successive zeros for HDB3 encoded data, or 16 or more successive zeros for non-HDB3 encoded data.
4	SaBorNi	Sa Bit or Nibble. Set this bit to determine the criteria for interrupts due to transitions of Sa bits. If set to one, a change of state of any Sa bit is the criteria. If set to zero, a change of state of an Sa nibble is the criteria. Note that the selected event can only trigger an interrupt if the interrupt mask bit SaIM is set high in the Interrupt Mask Word Two - page 1 address 1DH bit 0.
3	RxTRSP	Receive Transparent Mode. When this bit is set to one, the framing function is disabled on the receive side. Data coming from the receive line passes through the slip buffer and drives DSTo with an arbitrary alignment. When zero, the receive framing function operates normally.
2	TxTRSP	Transmit Transparent Mode. If one, the MT9076 is in transmit transparent mode. No framing or signaling is imposed on the data transmit from DSTi onto the line. If zero, it is in termination mode.
1	TIU1	Transmit International Use One. When CRC-4 operation is disabled ($\overline{\text{CSYN}}=1$), this bit is transmit on the PCM 30 2048 kbit/sec. link in bit position one of time-slot zero of non-frame-alignment frames. It is reserved for international use and should normally be kept at one. If CRC processing is used, i.e., $\overline{\text{CSYN}}=0$, this bit is ignored.
0	TIU0	Transmit International Use Zero. When CRC-4 operation is disabled ($\overline{\text{CSYN}}=1$), this bit is transmit on the PCM 30 2048 kbit/sec. link in bit position one of time-slot zero of frame-alignment frames. It is reserved for international use and should normally be kept at one. If CRC processing is used, i.e., $\overline{\text{CSYN}}=0$, this bit is ignored.

Table 88 - TS0 Control Word (E1)

(Page 1, Address 12H)

Bit	Name	Functional Description
7-4	TMA1-4	Transmit Multiframe Alignment Bits One to Four. These bits are transmitted on the PCM 30 2048 kbit/sec. link in bit positions one to four of time slot 16 of frame zero of every signaling multiframe. These bits are used by the far end to identify specific frames of a signaling multiframe. TMA1-4 = 0000 for normal operation.
3	X1	This bit is transmitted on the PCM 30 2048 kbit/sec. link in bit position five of time slot 16 of frame zero of every multiframe. X1 is normally set to one.
2	Y	This bit is transmitted on the PCM 30 2048 kbit/sec. link in bit position six of time slot 16 of frame zero of every multiframe. It is used to indicate the loss of multiframe alignment to the remote end of the link. If one - loss of multiframe alignment; if zero - multiframe alignment acquired. This bit is ignored when AUTY is zero (page 01H, address 11H).
1, 0	X2, X3	These bits are transmitted on the PCM 30 2048 kbit/sec. link in bit positions seven and eight respectively, of time slot 16 of frame zero of every multiframe. X2 and X3 are normally set to one.

Table 89 - Transmit Multiframe Alignment Signal (E1)

(Page 1, Address 13H)

Bit	Name	Functional Description
7	DSToEn	DSTo Enable. If zero pin DSTo is tristate. If set the pin DSTo is enabled.
6	CSToEn	CSTo Enable. If zero pin CSTo is tristate. If set the pin CSTo is enabled.
5	TxCCS	Transmit Common Channel signaling. If one, the transmit channel 16 of the device is in common channel signaling (CCS) mode. If zero, it is in Channel Associated signaling (CAS) mode, data for channel 16 is sourced from the internal transmission ABCD register.
4	DBNCE	Debounce Select. This bit selects the debounce period (1 for 14 msec.; 0 for no debounce). Note: there may be as much as 2 msec. added to this duration because the state change of the signaling equipment is not synchronous with the PCM 30 signaling multiframe.
3	MSN	Most Significant signaling Nibble. If one, the CSTo and CSTi channel associated signaling nibbles will be valid in the most significant portion of each ST-BUS time slot. If zero, the CSTo and CSTi channel associated signaling nibbles will be valid in the least significant portion of each ST-BUS time slot.
2,1,0	---	Unused.

Table 90 - Interrupt and Signaling Control Word (E1)

(Page 1, Address 14H)

Bit	Name	Functional Description
7	RxHDB3	High Density Bipolar 3 Encoding. If one, HDB3 encoding is enabled in the receive direction. If zero, AMI signal without HDB3 encoding is received.
6	MLBK	Metallic Loopback. If one, then the external RRTIP and RRING signals are isolated from the receiver, and TTIP and TRING are internally connected to the receiver analog input instead. If zero, metallic loopback is disabled.
5	TxHDB3	High Density Bipolar 3 Encoding. If one, HDB3 encoding is enabled in the transmit direction. If zero, AMI signal without HDB3 encoding is transmitted. HDB3 is always decoded in the receive direction.
4	---	Unused.
3	DLBK	Digital Loopback. If one, then the digital stream to the transmit LIU is looped back in place of the digital output of the receive LIU. Data coming out of DSTo will be a delayed version of DSTi. If zero, this feature is disabled.
2	RLBK	Remote Loopback. If one, then all bipolar data received on RRTIP/RRING are directly routed to TTIP/TRING on the PCM 30 side of the MT9076. If zero, then this feature is disabled.
1	SLBK	ST-BUS Loopback. If one, then all time slots of DSTi are connected to DSTo on the ST-BUS side of the MT9076. If zero, then this feature is disabled. See Loopbacks section.
0	PLBK	Payload Loopback. If one, then all time slots received on RTIP/RRING are connected to TTIP/TRING on the ST-BUS side of the MT9076 (this excludes time slot zero). If zero, then this feature is disabled.

Table 91 - Coding and Loopback Control Word (E1)

(Page 1, Address 15H)

Bit	Name	Functional Description
7 - 6	---	Unused.
5	TALM	Transmit Remote Alarm. This bit is transmitted on the PCM 30 2048 kbit/sec. link in bit position three (A bit) of time slot zero of NFAS frames. It is used to signal an alarm to the remote end of the PCM 30 link (one - alarm, zero - normal). This control bit is ignored when ARAI is zero (page 01H, address 10H).
4-0	TNU4-8	Transmit National Use Four to Eight (Sa4 - Sa8). These bits are transmitted on the PCM 30 2048 kbit/sec. link in bit positions four to eight of time slot zero of the NFA frame, if selected by Sa4 - Sa8 control bits of the DL selection word (page 01H, address 10H).

Table 92 - Non Frame Alignment Control Word (E1)

(Page 1, Address 16H)

Bit	Name	Functional Description
7	---	Unused.
6	MFSEL	Multiframe Select. This bit determines which receive multiframe signal (CRC-4 or signaling) the RxMF (pin 42 in PLCC, 23 in MQFP) signal is aligned with. If zero, RxMF is aligned with the receive signaling multiframe. If one, RxMF is aligned with the receive CRC-4 multiframe.
5	NBTB	National Bit Transmit Buffer. If one, the transmit NFAS signal originates from the transmit national bit buffer page 0EH; if zero, the transmit NFAS signal originates from the TNU4-8 bits of page 1 address 16H.
4-0	Sa4-Sa8	National Bit Data Link Select A one selects the corresponding Sa bits of the NFA signal for 4, 8, 12, 16 or 20 kbits/sec. data link channel. Data link (DL) selection will function in termination mode only; in transmit transparent mode Sa4 is automatically selected - see TxTRSP control bit of page 01H, address 11H. If zero, the corresponding bits of transmit non-frame alignment signal are programmed by the Non-Frame Alignment Control Word (page 01H, address 12H).

Table 93 - Multiframe and Data Link Selection (E1)

(Page 1, Address 17H)

Bit	Name	Functional Description
7-0	TxM7-0	Transmit Message Bits 7 - 0. The contents of this register are transmit into those outgoing DS1 channels selected by the Per Time Slot Control registers.

Table 94 - Transmit Message Word (E1)

(Page 1, Address 18H)

Bit	Name	Functional Description
7	BPVE	Bipolar Violation Error Insertion. A zero to one transition of this bit inserts a single bipolar violation error into the transmit PCM 30 data. A one, zero or one to zero transition has no function.
6	CRCE	CRC-4 Error Insertion. A zero to one transition of this bit inserts a single CRC-4 error into the transmit PCM 30 data. A one, zero, or one to zero transition has no function.
5	FASE	Frame Alignment Signal Error Insertion. A zero to one transition of this bit inserts a single error into the time slot zero frame alignment signal of the transmit PCM 30 data. A one, zero, or one to zero transition has no function.
4	NFSE	Non-frame Alignment Signal Error Insertion. A zero to one transition of this bit inserts a single error into bit two of the time slot zero non-frame alignment signal of the transmit PCM 30 data. A one, zero, or one to zero transition has no function.
3	LOSE	Loss of Signal Error Insertion. If one, the MT9076 transmits an all zeros signal (no pulses) in every PCM 30 time slot. When HDB3 encoding is activated no violations are transmitted. If zero, data is transmitted normally.
2	PERR	Payload Error Insertion. A zero to one transition of this bit inserts a single error in the transmit payload. A one, zero, or one to zero transition has no function.
1	L32Z	Digital Loss of Signal Selection. If one, the threshold for digital loss of signal is 32 successive zeros. If zero, the threshold is set to 192 successive zeros.
0	LOS/LOF	Loss of Signal or Loss of Frame Selection. If one, pin LOS (pin 61 in PLCC, 57 in MQFP) will go high when a loss of signal state exits. A loss of signal is defined as either receipt of a signal attenuated below the analog loss of signal threshold (selectable as 20 dB or 40 dB below nominal) or receipt of 256 consecutive 0's. If low, pin LOS will go high when either a loss of signal or a loss of basic frame alignment state exits (bit SYNC on page 03H address 10H is zero).

Table 95 - Error Insertion Word (E1)

(Page 1, Address 19H)

Bit	Name	Functional Description
7	RST	Reset. When this bit is changed from zero to one the device will reset to its default mode. See the Reset Operation section for the default settings.
6	SPND	Suspend Interrupts. If one, the IRQ output (pin 12 in PLCC, 85 in MQFP) will be in a high-impedance state and all interrupts will be ignored. If zero, the IRQ output will function normally.
5	INTA	Interrupt Acknowledge. A zero-to-one or one-to-zero transition will clear any pending interrupt and make IRQ high.
4	CNTCLR	Counter Clear. If one, all status counters are cleared and held low. Zero for normal operation.
3	SAMPLE	One Second Sample. Setting this bit causes the error counters (change of frame alignment, loss of frame alignment, lcv errors, crc errors, severely errored frame events and multiframes out of sync) to be updated on one second intervals coincident with the one second timer (status page 3 address 12H bit 7).
2	OOFB	Out of Frame Pause. If set high, this bit will suspend operation of the Line Code Violation Counter during an out - of - frame condition; upon achieving terminal frame synchronization the counter will resume normal operation. If set low, the Line Code Violation counter will continue to count errors even if terminal frame synchronization is lost.
1	--	Reserved. Set low for normal operation.
0	D20	Double 20. Set low for normal operation. Set high to double clock speed in the HDLC to speed up memory accesses from 160 ns between consecutive reads/writes to 80 ns between consecutive reads/writes.

Table 96 - Signaling Control Word (E1)

(Page 1, Address 1AH)

Bit	Name	Functional Description
7	SYNIM	Synchronization Interrupt Mask. When unmasked (SYNI = 1) an interrupt is initiated whenever a change of state of loss of basic frame synchronization condition exists. If 1- unmasked, 0 - masked.
6	MFSYIM	Multiframe Synchronization Interrupt Mask. When unmasked (MFSYI = 1), an interrupt is initiated whenever a change of state of multiframe synchronization exists. If 1- unmasked, 0 - masked.
5	CSYNIM	CRC-4 Multiframe Synchronization Interrupt Mask. When unmasked (CSYNI = 1), an interrupt is initiated whenever a change of state of CRC-4 multiframe synchronization exists. If 1- unmasked, 0 - masked.
4	AISIM	Alarm Indication Signal Interrupt Mask. When unmasked (AISI = 1) a change of state of received AIS will initiate an interrupt. If 1- unmasked, 0 - masked.
3	LOSIM	Loss of Signal Interrupt Mask. When unmasked this interrupt bit goes high whenever a change of state of loss of signal (either analog - received signal 20 or 40 dB below nominal or digital - 256 consecutive 0's received) condition exists. If 1- unmasked, 0 - masked.
2	CEFIM	Consecutively Errored FASs Interrupt Mask. When unmasked an interrupt is initiated when two consecutive errored frame alignment signals are received. If 1 - unmasked, 0 - masked.
1	YIM	Remote signaling Multiframe Alarm Interrupt Mask. When unmasked (YI = 1), an interrupt is initiated whenever a change of state of when a remote signaling multiframe alarm signal is received. If 1- unmasked, 0 - masked.
0	SLPIM	SLIP Interrupt Mask. When unmasked (SLPI = 1), an interrupt is initiated when a controlled frame slip occurs. If 1- unmasked, 0 - masked.

Table 97 - Interrupt Mask Word Zero (E1)

(Page 1, Address 1BH)

Bit	Name	Functional Description
7	FERIM	Frame Error Interrupt Mask. When unmasked (FERI = 1), an interrupt is initiated when an error in the frame alignment signal occurs. If 1- unmasked, 0 - masked.
6	CRCIM	CRC-4 Error Interrupt Mask. When unmasked an interrupt is initiated when a local CRC-4 error occurs. If 1 - unmasked, 0 - masked.
5	EBIM	Receive E-bit Interrupt Mask. When unmasked an interrupt is initiated when a receive E-bit indicates a remote CRC-4 error. If 1 - unmasked, 0 - masked.
4	AIS16IM	Channel 16 Alarm Indication Signal Interrupt Mask. When unmasked (AIS16I = 1), a received AIS16 will initiate an interrupt. If 1- unmasked, 0 - masked.
3	LCVIM	Line Code Violation Interrupt Mask. When unmasked an interrupt is initiated when a line code violation error occurs. If 1 - unmasked, 0 - masked.
2	PRBSIM	PRBS Interrupt Mask. When unmasked (PRBSI = 1), an interrupt is initiated on a single PRBS detection error. If 1- unmasked, 0 - masked.
1	AUXPIM	Auxiliary Pattern Interrupt Mask. When unmasked (AUXPI = 1), an interrupt is initiated when the AUXP status bit of page 03H, address 15H goes high. If 1- unmasked, 0 - masked.
0	RAIIM	Remote Alarm Indication Interrupt Mask. When unmasked (RAII = 1) a received RAI will initiate an interrupt. If 1- unmasked, 0 - masked.

Table 98 - Interrupt Mask Word One (E1)

(Page 1, Address 1CH)

Bit	Name	Functional Description
7	FEOM	Frame Alignment Signal Error Counter Overflow Interrupt Mask. When unmasked an interrupt is initiated when the frame alignment signal error counter overflows. If 1 - unmasked, 0 - masked.
6	CRCOIM	CRC-4 Error Counter Overflow Interrupt Mask. When unmasked an interrupt is initiated when the CRC-4 error counter overflows. If 1 - unmasked, 0 - masked.
5	---	Unused.
4	EBOIM	Receive E-bit Counter Overflow Interrupt Mask. When unmasked an interrupt is initiated when the E-bit error counter overflows. If 1 - unmasked, 0 - masked.
3	LCVCOM	Line Code Violation Counter Overflow Interrupt Mask. When unmasked (LCVO = 1), an interrupt is initiated when the line code violation error counter changes from FFFFH to 0H. If 1- unmasked 0 - masked.
2	PRBSOM	PRBS Counter Overflow Interrupt Mask. When unmasked (PRBSO = 1), an interrupt is initiated on overflow of PRBS counter (page 04H, address 10H) from FFH to 0H. If 1- unmasked 0 - masked.
1	PRBSMFOM	PRBS MultiFrame Counter Overflow Interrupt Mask. When unmasked an interrupt will be generated whenever the multiframe counter attached to the PRBS error counter overflows. If 1- unmasked 0 - masked.
0	SaIM	Sa Bits Interrupt Masks. When unmasked an interrupt will be triggered by either a change of state of any of the received Sa bits Sa5, Sa6, Sa7 or Sa8 (SaBorNi = 1) or a change of state of any of the received Sa nibbles (SaBorNi = 0). The control bit SaBorNi is located in page 1 address 12H bit 4. If 1- unmasked 0 - masked.

Table 99 - Interrupt Mask Word Two (E1) (Page 1, Address 1DH)

Bit	Name	Functional Description
7	HDLC0IM	HDLC0 Interrupt Mask. When unmasked an interrupt is triggered by an unmasked event in HDLC0. If 1 - unmasked, 0 - masked.
6	HDLC1IM	HDLC1 Interrupt Mask. When unmasked an interrupt is triggered by an unmasked event in HDLC1. If 1 - unmasked, 0 - masked.
5	HDLC2IM	HDLC2 Interrupt Mask. When unmasked an interrupt is triggered by an unmasked event in HDLC2. If 1 - unmasked, 0 - masked.
4	JAIM	Jitter Attenuation Interrupt Mask. When unmasked, an interrupt will be initiated when the jitter attenuator FIFO comes within four bytes of an overflow or underflow condition. If 1 - unmasked, 0 - masked.
3	1SECIM	One Second Status Interrupt Mask. When unmasked (1SECI = 1), an interrupt is initiated when the 1SEC status bit changes from zero to one. If 1- unmasked, 0 - masked.
2	5SECIM	Five Second Status Interrupt Mask. When unmasked (5SECI = 1), an interrupt is initiated when the 5SECI status bit changes from zero to one. If 1- unmasked, 0 - masked.
1	RCRIM	RCRI Interrupt Mask. Whenever an unmasked (RCRI=1), an interrupt is initiated when RCR (remote alarm & CRC-4 error) status bit changes from zero to one. If 1- unmasked, 0 - masked.
0	SIGIM	signaling (CAS) Interrupt Mask. When unmasked and any of the receive ABCD bits of any channel changes state an interrupt is initiated. If 1 - unmasked, 0 - masked.

Table 100 - Interrupt Mask Word Three (E1) (Page 1, Address 1EH)

Bit	Name	Functional Description
7	NRZ	NRZ Format Selection. Only used in the digital framer only mode (LIU is disabled). A one sets the MT9076 to accept a unipolar NRZ format input stream on RxA as the line input, and to transmit a unipolar NRZ format stream on TxB. A zero causes the MT9076 to accept a complementary pair of dual rail inputs on RxA/RxA and to transmit a complementary pair of dual rail outputs on TxA/TxB.
6 - 5	---	Reserved. Set these bits low for normal operation.
4-3	RxA1-0	Automatic Receive Equalizer Control. These bits should be programmed according to the table below: 00 Equalization will be activated using the control bits RxEQ2-0 11 The receive equalizer is turned on and will compensate for loop length automatically. The control bits RxEQ2-0 will be ignored. 01, 10 Reserved for factory purposes.
2-0	RxEQ2-0	Receive Equalization Select. Setting these pins forces a level of equalization of the incoming line data. RES2 RES1 RES0 Receive Equalization 0 0 0 none 0 0 1 8 dB 0 1 0 16 dB 0 1 1 24 dB 1 0 0 32 dB 1 0 1 40 dB 1 1 0 48 dB 1 1 1 reserved These settings have no effect if either of RxA1 and RxA0 are set to one.

Table 101 - LIU Receive Word (E1) (Page 1, Address 1FH)

20.4 Master Control 2 (Page-2)

20.4.1 Master Control 2 (Page 02H) (E1)

Address (A ₄ A ₃ A ₂ A ₁ A ₀)	Register	Names
10H (Table 103)	Configuration Control Word	T1/E1, TxEN, $\overline{\text{LIUEn}}$, ELOS, Tx8KEN, ADSEQ
11H (Table 104)	LIU Tx Word	WR, Pk2, Pk1, CPL, TxLB2-0
12H	Reserved	Set all bits to zero for normal operation.
13H (Table 105)	Jitter Attenuator Control Word	JFC, JFD2-JFD0, JA CL
14H	Reserved	Set all bits to zero for normal operation.
15H	Reserved	Set all bits to zero for normal operation.
16H (Table 106)	Equalizer High Threshold	EHT7-0
17H (Table 107)	Equalizer Low Threshold	ELT7-0
18H (Table 108)	Serial Bit Rate	IMA,8Men,8MTS1-0
19H (Table 109)	HDCL0 Select	En, $\overline{\text{SaSEL}}$, CH4-0
1AH (Table 110)	HDCL1 Select	En, CH4-0
1BH (Table 111)	HDCL2 Select	En, CH4-0
1CH (Table 112)	Custom Pulse Word 1	CP6-0
1DH (Table 113)	Custom Pulse Word 2	CP6-0
1EH (Table 114)	Custom Pulse Word 3	CP6-0
1FH (Table 115)	Custom Pulse Word 4	CP6-0

Table 102 - Master Control 2 (Page 02H) (E1)

Bit	Name	Functional Description
7	T1/E1	E1 mode selection. when this bit is one, the device is in E1 mode.
6	--	Reserved. Must be kept at 0 for normal operation.
5	TxEN	Transmit Enable. Setting this bit low turns off the TTIP and TRING output line drivers. Setting this bit high enables them.
4	LIUE _n	LIU Enable. Setting this bit low enables the internal LIU front-end. Setting this pin high disables the LIU. Digital inputs RXA and RXB are sampled by the rising edge of E2.0i (Exclk) to strobe in the received line data. Digital transmit data is clocked out of pins TXA and TXB with the rising edge of C2.0o
3	ELOS	ELOS Enable. Set this bit low to set the analog loss of signal threshold to 40 dB below nominal. Set this bit high to set the analog loss of signal threshold to 20 dB below nominal.
2	Tx8KEN	Transmit 8 KHz Enable. If one, the pin $\overline{\text{RxMF}}/\text{TxFP}$ transmits a positive 8 KHz frame pulse synchronous with the serial data stream transmit on TXA/TXB. If zero, the pin $\overline{\text{RxMF}}/\text{TxFP}$ transmits a negative frame pulse synchronous with the multiframe boundary of data coming out of DSTo.
1	ADSEQ	Digital Milliwatt or Digital Test Sequence. If one, the A-law digital milliwatt analog test sequence will be selected by the Per Time Slot Control bits TTST and RTST. If zero, a PRBS generator / detector will be connected to channels with TTST, RRST respectively
0	--	Reserved. Set this bit low for normal operation.

Table 103 - Configuration Control Word

(Page 2, Address 10H) (E1)

Bit	Name	Functional Description																																																															
7	WR	Winding Ratio. Set this pin low if a 1:2.4 transformer is used on the transmit side. Set this pin high if a 1:2 transformer is used.																																																															
6-4	--	Reserved. Must be kept at 0 for normal operation.																																																															
3	CPL	Custom Pulse Level. Setting this bit low enables the internal ROM values in generating the transmit pulses. The ROM is coded for different line terminations or build out, as specified in the LIU Control word. Setting this pin high disables the pre-programmed pulse templates. Each of the 4 phases that generate a mark derive their D/A coefficients from the values programmed in the CPW registers.																																																															
2 - 0	TX2-0	<p>Transmit pulse amplitude. Select the TX2 –TX0 bits according to the line type, value of termination resistors (RT), and transformer turns ratio used.</p> <table border="1"> <thead> <tr> <th>TX2</th> <th>TX1</th> <th>TX0</th> <th>Line Impedance (ohms)</th> <th>RT(ohms)</th> <th>Transformer Ratio</th> <th>WR (bit 7)</th> </tr> </thead> <tbody> <tr> <td>0</td> <td>0</td> <td>0</td> <td>120</td> <td>0</td> <td>1:2.4</td> <td>0</td> </tr> <tr> <td>0</td> <td>0</td> <td>1</td> <td>120</td> <td>6.8</td> <td>1:2</td> <td>0</td> </tr> <tr> <td>0</td> <td>1</td> <td>0</td> <td>120</td> <td>6.8</td> <td>1:2.4</td> <td>0</td> </tr> <tr> <td>0</td> <td>1</td> <td>1</td> <td>75</td> <td>5.1</td> <td>1:2.4</td> <td>0</td> </tr> <tr> <td>1</td> <td>0</td> <td>0</td> <td>-</td> <td>-</td> <td>-</td> <td>-</td> </tr> <tr> <td>1</td> <td>0</td> <td>1</td> <td>75</td> <td>6</td> <td>1:2</td> <td>1</td> </tr> <tr> <td>1</td> <td>1</td> <td>0</td> <td>75</td> <td>6</td> <td>1:2</td> <td>1</td> </tr> <tr> <td>1</td> <td>1</td> <td>1</td> <td>75</td> <td>5.1</td> <td>1:2.4</td> <td>0</td> </tr> </tbody> </table> <p>After reset, these bits are zero.</p>	TX2	TX1	TX0	Line Impedance (ohms)	RT(ohms)	Transformer Ratio	WR (bit 7)	0	0	0	120	0	1:2.4	0	0	0	1	120	6.8	1:2	0	0	1	0	120	6.8	1:2.4	0	0	1	1	75	5.1	1:2.4	0	1	0	0	-	-	-	-	1	0	1	75	6	1:2	1	1	1	0	75	6	1:2	1	1	1	1	75	5.1	1:2.4	0
TX2	TX1	TX0	Line Impedance (ohms)	RT(ohms)	Transformer Ratio	WR (bit 7)																																																											
0	0	0	120	0	1:2.4	0																																																											
0	0	1	120	6.8	1:2	0																																																											
0	1	0	120	6.8	1:2.4	0																																																											
0	1	1	75	5.1	1:2.4	0																																																											
1	0	0	-	-	-	-																																																											
1	0	1	75	6	1:2	1																																																											
1	1	0	75	6	1:2	1																																																											
1	1	1	75	5.1	1:2.4	0																																																											

Table 104 - LIU Tx Word
(Page 2, Address 11H) (E1)

Bit	Name	Functional Description																																				
7	---	Unused.																																				
6	JFC	Jitter Attenuator FIFO Centre. When this bit is toggled the read pointer on the jitter attenuator shall be centered. During this centering the jitter on the JA outputs is increased by 0.0625 U.I.																																				
5 - 3	JFD2-JFD0	<p>Jitter Attenuator FIFO Depth Control Bits. These bits determine the depths of the jitter attenuator FIFO as shown below:</p> <table border="1"> <thead> <tr> <th>JFD2</th> <th>JFD1</th> <th>JFD0</th> <th>Depth</th> </tr> </thead> <tbody> <tr> <td>0</td> <td>0</td> <td>0</td> <td>16</td> </tr> <tr> <td>0</td> <td>0</td> <td>1</td> <td>32</td> </tr> <tr> <td>0</td> <td>1</td> <td>0</td> <td>48</td> </tr> <tr> <td>0</td> <td>1</td> <td>1</td> <td>64</td> </tr> <tr> <td>1</td> <td>0</td> <td>0</td> <td>80</td> </tr> <tr> <td>1</td> <td>0</td> <td>1</td> <td>96</td> </tr> <tr> <td>1</td> <td>1</td> <td>0</td> <td>112</td> </tr> <tr> <td>1</td> <td>1</td> <td>1</td> <td>128</td> </tr> </tbody> </table>	JFD2	JFD1	JFD0	Depth	0	0	0	16	0	0	1	32	0	1	0	48	0	1	1	64	1	0	0	80	1	0	1	96	1	1	0	112	1	1	1	128
JFD2	JFD1	JFD0	Depth																																			
0	0	0	16																																			
0	0	1	32																																			
0	1	0	48																																			
0	1	1	64																																			
1	0	0	80																																			
1	0	1	96																																			
1	1	0	112																																			
1	1	1	128																																			
2	JACL	Jitter Attenuator FIFO Clear Bit. If one, the Jitter Attenuator, its FIFO and status are reset. The status registers will identify the FIFO as being empty. However, the actual bit values of the data in the JA FIFO will not be reset.																																				
1 - 0	---	Unused.																																				

**Table 105 - Jitter Attenuation Control Word
(Page 2, Address 13H) (E1)**

Bit	Name	Functional Description
7-0	EHT7-0	Equalizer High Threshold. These bits set the highest possible binary count tolerable coming out of the equalized signal peak detector before a lower level of equalization is selected. This register is only used when A/D based automatic equalization is selected using the Rx LIU Control Word. The recommended value to program is 10111011.

**Table 106 - Equalizer High Threshold
(Page 2, Address 16H) (E1)**

Bit	Name	Functional Description
7-0	ELT7-0	Equalizer Low Threshold. These bits set the lowest possible binary count tolerable coming out of the equalized signal peak detector before a higher level of equalization is selected. This register is only used when A/D based automatic equalization is selected using the Rx LIU Control Word. The recommended value to program is 00110000.

**Table 107 - Equalizer Low Threshold
(Page 2, Address 17H) (E1)**

Bit	Name	Functional Description															
7 - 6	--	Reserved. Must be kept at 0 for normal operation.															
5	IMA	Inverse Mux Mode. Setting this bit high the I/O ports to allow for easy connection to the Zarlink MT90220. DSTi becomes a serial 2.048 data stream. C4b becomes a 2.048 MHz clock that clocks DSTi in on the falling edge. RXFP becomes a positive framing pulse that is high for the first bit of the serial E1 stream coming from the pin DSTo. The data from DSTo is clocked out on the rising edge of Exclk. Set this pin low for all other applications.															
4 - 3	--	Reserved. Must be kept at 0 for normal operation.															
2	8Men	8 Mb/s Bit Rate Select. Setting this bit low enables a serial bit rate on DSTi, CSTi and DSTo, CSTo of 2.048 Mb/s. Setting this bit high enables a gapped serial bit rate of 8.192 Mb/s on DSTi, CSTi, DSTo and CSTo.															
1 - 0	8MTS1- 0	<p>8 Mb/s Time Slot Select. These two bits select the active timeslots on the serial 8.192 Mb/s channels. During the active timeslots incoming serial data on DSTi and CSTi is clocked into the device, and data is clocked out onto DSTo and CSTo. During inactive timeslots DSTo and CSTo are tristate. For all selections every fourth 8 Mb/s timeslot is active.</p> <p>The timeslot selection is as follows:</p> <table border="1"> <thead> <tr> <th>8MTS1</th> <th>8MST0</th> <th>Active timeslots</th> </tr> </thead> <tbody> <tr> <td>0</td> <td>0</td> <td>0,4,8,12,16,20,24,28,32,36,40,44,48,52,56,60,64,68,72,76,80,84,88,92,96,100,104,108,112,116,120,124</td> </tr> <tr> <td>0</td> <td>1</td> <td>1,5,9,13,17,21,25,29,33,37,41,45,49,53,57,61,65,69,73,77,81,85,89,93,97,101,105,109,113,117,121,125</td> </tr> <tr> <td>1</td> <td>0</td> <td>2,6,10,14,18,22,26,30,34,38,42,46,50,54,58,62,66,70,74,78,82,86,90,94,98,102,106,110,114,118,122,126</td> </tr> <tr> <td>1</td> <td>1</td> <td>3,7,11,15,19,23,27,31,35,39,43,47,51,55,59,63,67,71,75,79,83,87,91,95,99,103,107,111,115,119,123,127</td> </tr> </tbody> </table>	8MTS1	8MST0	Active timeslots	0	0	0,4,8,12,16,20,24,28,32,36,40,44,48,52,56,60,64,68,72,76,80,84,88,92,96,100,104,108,112,116,120,124	0	1	1,5,9,13,17,21,25,29,33,37,41,45,49,53,57,61,65,69,73,77,81,85,89,93,97,101,105,109,113,117,121,125	1	0	2,6,10,14,18,22,26,30,34,38,42,46,50,54,58,62,66,70,74,78,82,86,90,94,98,102,106,110,114,118,122,126	1	1	3,7,11,15,19,23,27,31,35,39,43,47,51,55,59,63,67,71,75,79,83,87,91,95,99,103,107,111,115,119,123,127
8MTS1	8MST0	Active timeslots															
0	0	0,4,8,12,16,20,24,28,32,36,40,44,48,52,56,60,64,68,72,76,80,84,88,92,96,100,104,108,112,116,120,124															
0	1	1,5,9,13,17,21,25,29,33,37,41,45,49,53,57,61,65,69,73,77,81,85,89,93,97,101,105,109,113,117,121,125															
1	0	2,6,10,14,18,22,26,30,34,38,42,46,50,54,58,62,66,70,74,78,82,86,90,94,98,102,106,110,114,118,122,126															
1	1	3,7,11,15,19,23,27,31,35,39,43,47,51,55,59,63,67,71,75,79,83,87,91,95,99,103,107,111,115,119,123,127															

Table 108 - Serial Bit Rate

(Page 2, Address 18H) (E1)

Bit	Name	Functional Description
7	En	Enable. Set high to attach the HDLC0 controller to the channel specified below. Set low to disconnect the HDLC0.
6	SaSEL	Sa Bits Select. Set this bit to 0 to attach HDLC0 to the Sa bits. Set this bit to 1 to attach HDLC0 to a payload timeslot.
5	--	Reserved. Must be kept at 0 for normal operation.
4-0	CH4-0	Channel 4-0. This 5 bit number specifies the channel time HDLC0 will be attached to if enabled. Channel 0 is the first channel in the frame. Channel 31 is the last channel in an E1 frame. If enabled in a channel, HDLC data will be substituted for data from DSTi on the transmit side. Receive data is extracted from the incoming line data before the elastic buffer.

Table 109 - HDLC0 Select

(Page 2, Address 19H) (E1)

Bit	Name	Functional Description
7	En	Enable. Set high to attach the HDLC1 controller to the channel specified below. Set low to disconnect the HDLC1.
6-5	--	Reserved. Must be kept at 0 for normal operation.
4-0	CH4-0	Channel 4-0. This 5 bit number specifies the channel time HDLC1 will be attached to if enabled. Channel 0 is the first channel in the frame. Channel 31 is the last channel in an E1 frame. If enabled in a channel, HDLC data will be substituted for data from DSTi on the transmit side. Receive data is extracted from the incoming line data before the elastic buffer. Channel 0 selection is unavailable to this controller.

Table 110 - HDLC1 Select

(Page 2, Address 1AH) (E1)

Bit	Name	Functional Description
7	En	Enable. Set high to attach the HDLC2 controller to the channel specified below. Set low to disconnect the HDLC2.
6-5	--	Reserved. Must be kept at 0 for normal operation.
4-0	CH4-0	Channel 4-0. This 5 bit number specifies the channel time HDLC2 will be attached to if enabled. Channel 0 is the first channel in the frame. Channel 31 is the last channel in an E1 frame. If enabled in a channel, HDLC data will be substituted for data from DSTi on the transmit side. Receive data is extracted from the incoming line data before the elastic buffer. Channel 0 selection is unavailable to this controller.

Table 111 - HDLC2 Select

(Page 2, Address 1BH) (E1)

Bit	Name	Functional Description
7	--	Reserved. Must be kept at 0 for normal operation.
6-0	CP6-0	Custom Pulse. These bits provide the capability for programming the magnitude setting for the TTIP/TRING line driver A/D converter during the first phase of a mark. The greater the binary number loaded into the register, the greater the amplitude driven out. This feature is enabled when the control bit 3 - CPL of the Custom Tx Pulse Enable Register - address 11H of Page 2 is set high

Table 112 - Custom Pulse Word 1

(Page 2, Address 1CH) (E1)

Bit	Name	Functional Description
7	--	Reserved. Must be kept at 0 for normal operation.
6-0	CP6-0	Custom Pulse. These bits provide the capability for programming the magnitude setting for the TTIP/TRING line driver A/D converter during the second phase of a mark. The greater the binary number loaded into the register, the greater the amplitude driven out. This feature is enabled when the control bit 3 - CPL of the Custom Tx Pulse Enable Register - address 11H of Page 2 is set high

Table 113 - Custom Pulse Word 2
(Page 2, Address 1DH) (E1)

Bit	Name	Functional Description
7	--	Reserved. Must be kept at 0 for normal operation.
6-0	CP6-0	Custom Pulse. These bits provide the capability for programming the magnitude setting for the TTIP/TRING line driver A/D converter during the third phase of a mark. The greater the binary number loaded into the register, the greater the amplitude driven out. This feature is enabled when the control bit 3 - CPL of the Custom Tx Pulse Enable Register - address 11H of Page 2 is set high

Table 114 - Custom Pulse Word 3
(Page 2, Address 1EH) (E1)

Bit	Name	Functional Description
7	--	Reserved. Must be kept at 0 for normal operation.
6-0	CP6-0	Custom Pulse. These bits provide the capability for programming the magnitude setting for the TTIP/TRING line driver A/D converter during the fourth phase of a mark. The greater the binary number loaded into the register, the greater the amplitude driven out. This feature is enabled when the control bit 3 - CPL of the Custom Tx Pulse Enable Register - address 11H of Page 2 is set high

Table 115 - Custom Pulse Word 4
(Page 2, Address 1FH) (E1)

20.5 Master Status 1 (Page 03H) (E1)

Address (A ₄ A ₃ A ₂ A ₁ A ₀)	Register	Function
10H (Table 117)	Synchronization Status Word	SYN \bar{C} MFSYN \bar{C} CRCSYN \bar{N} REB1 REB2 CRCRF RED CRCIWK
11H (Table 118)	Alarm Status Word 1	CRCS1 CRCS2 RFAIL LOSS AIS16S AISS RAIS RCRS
12H (Table 119)	Timer Status Word	1SEC, 2SEC, 400T, 8T, CALN, KLVE, T1,T2
13H (Table 120)	Most Significant Phase Status Word	RSLIP, RSLPD, RxFRM, AUXP, RxFT, RxSBD2-0
14H (Table 121)	Least Significant Phase Status Word	RxTS4-0, RxBC2-0
15H (Table 122)	Receive Frame Alignment Signal	RIU0 &RFA2-8
16H (Table 123)	Receive Signal Status Word	LLOS
17H (Table 124)	Jitter Attenuator Status Word	JACS, JACF, JAE, JAF4, JAF4, JAE4, JAF
18H (Table 125)	Receive Non-frame Alignment Signal	RIU1, RNFAB, RALM, &RNU4-8
19H (Table 126)	Receive Multiframe Alignment Signal	RMAI1-4, X1, Y, X2, & X3
1AH (Table 127)	Sa Bits Report Word	Sa5, Sa6nibble, C8Sa6, CSa6, RxSa3-0
1BH (Table 128)	Alarm Status Word 2	RAIS, AISS, AIS16S, LOSS, AUXPS, MFALMS, SLIPS
1CH	---	Reserved.
1DH (Table 129)	Analog Peak Detector	AP7-0
1EH	---	Reserved.
1FH (Table 130)	Identification Word	Set to 01111000

Table 116 - Master Status 1 (Page 3) (E1)

Bit	Name	Functional Description
7	$\overline{\text{SYNC}}$	Receive Basic Frame Alignment. SYNC indicates the basic frame alignment status (1 - loss; 0 - acquired).
6	$\overline{\text{MFSYNC}}$	Receive Multiframe Alignment. MFSYNC indicates the multiframe alignment status (1 - loss; 0 - acquired).
5	$\overline{\text{CRCSYN}}$	Receive CRC-4 Synchronization. CRCSYN indicates the CRC-4 multiframe alignment status (1 - loss; 0 - acquired).
4	REB1	Receive E-Bit One Status. REB1 indicates the status of the received E1 bit of the last multiframe.
3	REB2	Receive E-Bit Two Status. REB2 indicates the status of the received E2 bit of the last multiframe.
2	CRCRF	CRC-4 Reframe. A one indicates that the receive CRC-4 multiframe synchronization could not be found within the time out period of 8 msec. after detecting basic frame synchronization. This will force a reframe when the maintenance option is selected and automatic CRC-4 interworking is de-selected.
1	RED	RED Alarm. RED goes high when basic frame alignment has been lost for at least 100 msec. This bit will be low when basic frame alignment is acquired (I.431).
0	CRCIWK	CRC-4 Interworking. CRCIWK indicates the CRC-4 interworking status (1 - CRC-to-CRC; 0 - CRC-to-non-CRC).

Table 117 - Synchronization Status Word

(Page 3, Address 10H) (E1)

Bit	Name	Functional Description
7	CRCS1	Receive CRC Error Status One. If one, the evaluation of the last received submultiframe 1 resulted in an error. If zero, the last submultiframe 1 was error free. Updated on a submultiframe 1 basis.
6	CRCS2	Receive CRC Error Status Two. If one, the evaluation of the last received submultiframe 2 resulted in an error. If zero, the last submultiframe 2 was error free. Updated on a submultiframe 2 basis.
5	RFAIL	Remote CRC-4 Multiframe Generator/Detector Failure. If one, then each of the previous five seconds have an E-bit error count of greater than 989, and for this <u>same</u> period the receive RAI bit was zero (no remote alarm), and for the same period the SYNC bit was equal to zero (basic frame alignment has been maintained). If zero, indicates normal operation.
4	LOSS	Loss of Signal Status. If one, indicates the presence of a loss of signal condition. If zero, indicates normal operation. A loss of signal condition occurs when excess consecutive bit periods are zero. The threshold for this condition is set by the control bit L32Z. If L32Z is set high the threshold is 32 successive zeros. If L32Z is set low the threshold is 192 successive zeros. A loss of signal condition terminates when an average ones density of at least 12.5% has been received over a period of 192 contiguous pulse positions starting with a pulse.
3	AIS16S	Alarm Indication Signal 16 Status. If one, indicates an all ones alarm is being received in channel 16. If zero, normal operation. Updated on a frame basis.
2	AISS	Alarm Indication Status Signal. If one, indicates that a valid AIS or all ones signal is being received. If zero, indicates that a valid AIS signal is not being received. The criteria for AIS detection is determined by the control bit ASEL.
1	RAIS	Remote Alarm Indication Status. If one, there is currently a remote alarm condition (i.e., received A bit is one). If zero, normal operation. Updated on a non-frame alignment frame basis.
0	RCRS	RAI and Continuous CRC Error Status. If one, there is currently an RAI and continuous CRC error condition. If zero, normal operation. Updated on a multiframe basis.

Table 118 - Alarm Status Word 1
(Page 3, Address 11H) (continued) (E1)

Bit	Name	Functional Description
7	1SEC	One Second Timer Status. This bit changes state once every 0.5 second and is synchronous with the 2SEC timer. This feature is not available when the device is operated in freerun mode.
6	2SEC	Two Second Timer Status. This bit changes state once every second and is synchronous with the 1SEC timer. This feature is not available when the device is operated in freerun mode.
5	400T	400 msec. Timer Status. This bit changes state when the 400 msec. CRC-4 multiframe alignment timer expires.
4	8T	8 msec. Timer Status. This bit changes state when the 8 msec. CRC-4 multiframe alignment timer expires.
3	CALN	CRC-4 Alignment. This bit changes state every millisecond. When CRC-4 multiframe alignment has been achieved state changes of this bit are synchronous with the receive CRC-4 synchronization signal.
2	KLVE	Keep Alive. This bit is high when the AIS status bit has been high for at least 100 msec. This bit will be low when AIS goes low (I.431).
1	T1	Timer One. This bit will be high upon loss of terminal frame synchronization persisting for 100 msec. This bit shall be low when T2 becomes high. Refer to I.431 Section 5.9.2.2.3.
0	T2	Timer Two. This bit will be high when the MT9076 acquires terminal frame synchronization persisting for 10 msec. This bit shall be low when non-normal operational frames are received. I.431 Section 5.9.2.2.3.

Table 119 - Timer Status Word

(Page 3, Address 12H) (E1)

Bit	Name	Functional Description
7	RSLIP	Receive Slip. A change of state (i.e., 1-to-0 or 0-to-1) indicates that a receive controlled frame slip has occurred.
6	RSLPD	Receive Slip Direction. If one, indicates that the last received frame slip resulted in a repeated frame, i.e., system clock is faster than network clock. If zero, indicates that the last received frame slip resulted in a lost frame, i.e., system clock is slower than network clock. Updated on an RSLIP occurrence basis.
5	RXFRM	Receive Frame Delay. The most significant bit of the Receive Slip Buffer Phase Status Word. If one, the delay through the receive elastic buffer is greater than one frame in length; if zero, the delay through the receive elastic buffer is less than one frame in length.
4	AUXP	Auxiliary Pattern. This bit will go high when a continuous 101010... bit stream (Auxiliary Pattern) is received on the PCM 30 link for a period of at least 512 bits. If zero, auxiliary pattern is not being received. This pattern will be decoded in the presence of a bit error rate of as much as 10 ⁻³ .
3	RxFT	Receiver Frame Toggle. This bit toggles on the falling edge of RxTS4.
2-0	RxSBD2-0	Receive Sub Bit Delay. The three least significant bits of the Receive Slip Buffer Phase Status Word. They indicate the clock, half clock and one eight clock cycle depth of the phase status word sample point (bits 2, 1, 0 respectively).

Table 120 - Most Significant Phase Status Word

(Page 3, Address 13H) (E1)

Bit	Name	Functional Description
7 - 3	RxTS4 - 0	Receive Time Slot. A five bit counter that indicates the number of time slots between the receive elastic buffer internal write frame boundary and the ST-BUS read frame boundary. The count is updated every 250 uS.
2 - 0	RxBC2 - 0	Receive Bit Count. A three bit counter that indicates the number of STBUS bit times there are between the receive elastic buffer internal write frame boundary and the ST-BUS read frame boundary. The count is updated every 250 uS.

Table 121 - Least Significant Phase Status Word

(Page 3, Address 14H) (E1)

Bit	Name	Functional Description
7	RIU0	Receive International Use Zero. This is the bit which is received on the PCM 30 2048 kbit/sec. link in bit position one of the frame alignment signal. It is used for the CRC-4 remainder or for international use.
6 - 0	RFA2-8	Receive Frame Alignment Signal Bits 2 to 8. These bit are received on the PCM 30 2048 kbit/sec. link in bit positions two to eight of frame alignment signal. These bits form the frame alignment signal and should be 0011011.

Table 122 - Receive Frame Alignment Signal

(Page 3, Address 15H) (E1)

Bit	Name	Functional Description
7	LLOSS	LIU Loss of Signal indication. This bit will be high if the received signal is below the threshold selected by ELOS (page 2, address 10H) for a period of at least 1 msec. This bit will be low for normal operation.
6-0	---	Unused.

**Table 123 - Receive Signal Status Word
(Page 3, Address 16H) (E1)**

Bit	Name	Functional Description
7	JACS	Jitter Attenuated Clock Slow. If one it indicates that the dejittered clock period is increased by 1/16 UI. If zero the clock is at normal speed.
6	JACF	Jitter Attenuated Clock Fast. If one it indicates that the dejittered clock period is decreased by 1/16 UI. If zero the clock is at normal speed.
5	JAE	Jitter Attenuator FIFO Empty. If one it indicates that the JA FIFO is empty.
4	JAF4	Jitter Attenuator FIFO with 4 Full Locations. If one it indicates that the JA FIFO has at least 4 full locations.
3	J AFC	Jitter Attenuator Center Full. If one it indicates that the JA FIFO is at least half full.
2	JAE4	Jitter Attenuator FIFO with 4 Empty Locations. If one it indicates that the JA FIFO has at most 4 empty locations.
1	JAF	Jitter Attenuator FIFO Full. If one it indicates that the JA FIFO is full.
0	---	Unused.

**Table 124 - Jitter Attenuator Status Word
(Page 3, Address 17H) (E1)**

Bit	Name	Functional Description
7	RIU1	Receive International Use 1. This bit is received on the PCM 30 2048 kbit/sec. link in bit position one of the non-frame alignment signal. It is used for CRC-4 multiframe alignment or international use.
6	RNFAB	Receive Non-frame Alignment Bit. This bit is received on the PCM 30 2048 kbit/sec. link in bit position two of the non-frame alignment signal. This bit should be one in order to differentiate between frame alignment frames and non-frame alignment frames.
5	RALM	Receive Alarm. This bit is received on the PCM 30 2048 kbit/sec. link in bit position three (the A bit) of the non-frame alignment signal. It is used as a remote alarm indication (RAI) from the far end of the PCM 30 link (1 - alarm, 0 - normal).
4-0	RNU4-8	Receive National Use Four to Eight. These bits are received on the PCM 30 2048 kbit/sec. link in bit positions four to eight (the Sa bits) of the non-frame alignment signal.

Table 125 - Receive Non-Frame Alignment Signal

(Page 3, Address 18H) (E1)

Bit	Name	Functional Description
7-4	RMAI1-4	Receive Multiframe Alignment Bits One to Four. These bits are received on the PCM 30 2048 kbit/sec. link in bit positions one to four of time slot 16 of frame zero of every signaling multiframe. These bit should be 0000 for proper signaling multiframe alignment.
3	X1	Receive Spare Bit X1. This bit is received on the PCM 30 2048 kbit/sec. link in bit position five of time slot 16 of frame zero of every signaling multiframe.
2	Y	Receive Y-bit. This bit is received on the PCM 30 2048 kbit/sec. link in bit position six of time slot 16 of frame zero of every signaling multiframe. The Y bit may indicate loss of multiframe alignment at the remote end (1 -loss of multiframe alignment; 0 - multiframe alignment acquired).
1-0	X2, X3	Receive Spare Bits X2 and X3. These bits are received on the PCM 30 2048 kbit/sec. link in bit positions seven and eight respectively, of time slot 16 of frame zero of every signaling multiframe.

Table 126 - Receive Multiframe Alignment Signal

(Page 3, Address 19H) (E1)

Bit	Name	Functional Description
7	Sa5	Sa 5 Bit. The Sa5 bit is latched and reported here upon receipt of the eighth of consecutive instance of a new Sa6 nibble.
6	CSa6nibble	Changed Sa6 Nibble. This bit changes state upon detection of a change of state of incoming Sa6 nibbles.
5	C8Sa6	Changed Eight Sa6 Bit. This bit toggles upon receipt of the eighth of consecutive instance of a new Sa6 nibble.
4	CSa6	Changed Sa6 Bit. This bit toggles in the event of a change of state in the received Sa6 bit.
3 - 0	RxSa 3-0	Receive Sa Nibble Three to Zero. This register contains the contents of the last Sa6 nibble received. It is updated upon receipt of the eighth of consecutive instance of a new Sa6 nibble.

Table 127 - Sa Bits Report Word

(Page 3, Address 1AH) (E1)

Bit	Name	Functional Description
7	RAIS	Remote Alarm Indication Status. If one, there is currently a remote alarm condition (i.e., received A bit is one). If zero, normal operation. Updated on a non-frame alignment frame basis.
6	AISS	Alarm Indication Status Signal. If one, indicates that a valid AIS or all ones signal is being received. If zero, indicates that a valid AIS signal is not being received. The criteria for AIS detection is determined by the control bit ASEL.
5	AIS16S	Alarm Indication Signal 16 Status. If one, indicates an all ones alarm is being received in channel 16. If zero, normal operation. Updated on a frame basis.
4	LOSS	Loss of Signal Status. If one, indicates the presence of a loss of signal condition. If zero, indicates normal operation. A loss of signal condition occurs when an excess consecutive bit periods are zero. The threshold for this condition is set by the control bit L32Z. If L32Z is set high the threshold is 32 successive zeros. If L32Z is set low the threshold is 192 successive zeros. A loss of signal condition terminates when an average ones density of at least 12.5% has been received over a period of 192 contiguous pulse positions starting with a pulse.
3	AUXPS	Auxiliary Pattern Status. This bit goes on high when a continuous 101010... bit stream (Auxiliary Pattern) is received on the PCM 30 link for a period of at least 512 bits. If zero, auxiliary pattern is not being received. This pattern will be decoded in the presence of a bit error rate of as much as 10 ⁻³ .
2	MFALMS	Multiframe Alarm Status. This bit goes high in the event of receipt of a multiframe alarm. It goes low when the received multiframe alarm bit goes low.
1	RSLIPS	Receive Slip Status. A change of state (i.e., 1-to-0 or 0-to-1) indicates that a receive controlled frame slip has occurred.
0	---	Unused.

Table 128 - Alarm Status Word 2

(Page 3, Address 1BH) (E1)

Bit	Name	Functional Description
7 - 0	AP7-0	Analog Peak Detector. This status register gives the output value of a 8 bit A/D converter connected to a peak detector on RTIP/RRING.

Table 129 - Analog Peak Detector

(Page 3, Address 1DH) (E1)

Bit	Name	Functional Description
7-0	ID7-0	ID Number. Contains device code 01111000

Table 130 - Identification Word

(Page 3, Address 1FH) (E1)

21.0 Master Status 2 (Page-4)

21.1 Master Status 2 (Page 04H) (E1)

Address (A ₄ A ₃ A ₂ A ₁ A ₀)	Register	Function
10H (Table 132)	PRBS Error Counter	PS7-0
11H (Table 133)	CRC Multiframe counter for PRBS	PSM7-0
12H (Table 134)	Alarm Reporting Latch	RAI, AIS, AIS16, LOS, AUXP, MFALM, RSLIP
13H (Table 135)	Errored Frame Alignment Signal Counter	EFAS7-0
14H (Table 136)	E-bit Error Counter Ebt	EC15-EC8
15H (Table 137)	E-bit Error Counter Ebt	EC7-EC0
16H (Table 138)	Most Significant Line Code Violation Error Counter	LCV15 - LCV8
17H (Table 139)	Least Significant Line Code Violation Error Counter	LCV7 - LCV0
18H (Table 140)	CRC- 4 Error Counter CEt	CC15-CC8
19H (Table 141)	CRC- 6 Error Counter CEt	CC7 - CC0
1AH		Unused.
1BH (Table 142)	Interrupt Word Zero	TFSYNI, MFSYNI, CRCSYNI,AISI, LOSI, CEFI,YI, RxSLPI
1CH (Table 143)	Interrupt Word One	FERRI, CRCERRI, EBITI, AIS16I, LCVI, PRBSERRI, AUXPI, RAI,
1DH (Table 144)	Interrupt Word Two	FERRO,CRCO,FECEO,LCVO,PRBSO,PRBS MFO, SaI
1EH (Table 145)	Interrupt Word Three	HDLC0I,HDLC1I,HDLC2,JAI,1SECI,5SECI,RC RI,SIGI
1FH (Table 146)	Overflow Reporting Latch	FERROL,CRCOL,FEBEOL,LCVOL, PRBSOL, PRBSMFOL

Table 131 - Master Status 2 (Page 4) (E1)

Bit	Name	Functional Description
7 - 0	PS7-0	This counter is incremented for each PRBS error detected on any of the receive channels connected to the PRBS error detector.

**Table 132 - PRBS Error Counter
(Page 4, Address 10H) (E1)**

Bit	Name	Functional Description
7 - 0	PSM7-0	This counter is incremented for each received CRC multiframe. It is cleared when the PRBS Error Counter is written to.

Table 133 - CRC Multiframe Counter for PRBS

(Page 4, Address 11H) (E1)

Bit	Name	Functional Description
7	RAI	Remote Alarm Indication. This bit is set to one in the event of receipt of a remote alarm, i.e., A(RAI) = 1. It is cleared when the register is read.
6	AIS	Alarm Indication Signal. This bit is set to one in the event of receipt of an all ones alarm. It is cleared when the register is read.
5	AIS16	AIS Time Slot 16 Alarm. This bit is set to one in the event of receipt of an all ones alarm in the time slot 16. It is cleared when the register is read.
4	LOS	Loss of Signal. This bit is set to one in the event of loss of received signal. It is cleared when the register is read.
3	AUXP	Auxiliary Alarm. This bit is set to one in the event of receipt of the auxiliary alarm pattern. It is cleared when the register is read.
2	MFALM	Multiframe Alarm. This bit is set to one in the event of receipt of a multiframe alarm. It is cleared when the register is read.
1	RSLIP	Received Slip. This bit is set to one in the event of receive elastic buffer slip. It is cleared when the register is read.
0	---	Unused.

Table 134 - Alarm Reporting Latch

(Page 4, Address 12H) (E1)

Bit	Name	Functional Description
7 - 0	EFAS7 - 0	Errored FAS Counter. An 8 bit counter that is incremented once for every receive frame alignment signal that contains one or more errors.

Table 135 - Errored Frame Alignment Signal Counter

(Page 4, Address 13H) (E1)

Bit	Name	Functional Description
1-0	EC15-8	E bit Error Counter. The most significant bits of the E bit error counter.

Table 136 - E-bit Error Counter

(Page 4, Address 14H) (E1)

Bit	Name	Functional Description
7 - 0	EC7-0	E bit Error Counter. The least significant 8 bits of the E-bit error counter.

Table 137 - E-bit Error Counter

(Page 4, Address 15H) (E1)

Bit	Name	Functional Description
7 - 0	LCV15 - 8	Most Significant Bits of the LCV Counter. The most significant eight bits of a 16 bit counter that is incremented once for every line code violation received. A line code is defined as a bipolar violation that is not a part of HDB3 encoding where the control bit EXZ is set low. Where EXZ is set high a violation is defined as either a non-HDB3 bipolar violation or an occurrence of excess zeros.

Table 138 - Most Significant Bits of the LCV Counter

(Page 4, Address 16H) (E1)

Bit	Name	Functional Description
7 - 0	LCV7 - 0	Least Significant Bits of the LCV Counter. The least significant eight bits of a 16 bit counter that is incremented once for every line code violation received. A line code is defined as a bipolar violation that is not a part of HDB3 encoding where the control bit EXZ is set low. Where EXZ is set high a violation is defined as either a non-HDB3 bipolar violation or an occurrence of excess zeros.

Table 139 - Least Significant Bits of the LCV Counter

(Page 4, Address 17H) (E1)

Bit	Name	Functional Description
7-0	CC15 - 8	CRC-4 Error Counter These are the most significant eight bits of the CRC-6 error counter.

Table 140 - CRC-4 Error Counter CEt

(Page 4, Address 18H) (E1)

Bit	Name	Functional Description
7 - 0	CC7 - 0	CRC-6 Error Counter. These are the least significant eight bits of the CRC-4 error counter.

Table 141 - CRC-6 Error Counter CEt

(Page 4, Address 19H) (E1)

Bit	Name	Functional Description
7	TFSYNI	Terminal Frame Synchronization Interrupt. When unmasked this interrupt bit goes high whenever a change of state of terminal frame synchronization condition exists. Reading this register clears this bit.
6	MFSYNI	Multiframe Synchronization Interrupt. When unmasked this interrupt bit goes high whenever a change of state of multiframe synchronization condition exists. Reading this register clears this bit.
5	CRCSYNI	CRC-4 Synchronization Interrupt. When unmasked this interrupt bit goes high whenever change of state of CRC-4 synchronization condition exists. Reading this register clears this bit.
4	AISI	Alarm Indication Signal Interrupt. When unmasked this interrupt bit goes high whenever a change of state of received all ones condition exists. Reading this register clears this bit.
3	LOSI	Loss of Signal Interrupt. When unmasked this interrupt bit goes high whenever a loss of signal (either analog - received signal 20 or 40 dB below nominal or digital - excess consecutive 0's received) condition exists.
2	CEFI	Consecutively Errored Frame Alignment Interrupt. When unmasked this interrupt bit goes high whenever the last two frame alignment signals have errors. Reading this register clears this bit.
1	YI	Receive Y-bit Interrupt. When unmasked this interrupt goes high whenever loss of multiframe alignment occurs. Reading this register clears this bit.
0	RxSLPI	Receive SLIP Interrupt. When unmasked this interrupt bit goes high whenever a controlled frame slip occurs in the receive elastic buffer. Reading this register clears this bit.

Table 142 - Interrupt Word Zero

(Page 4, Address 1BH) (E1)

Bit	Name	Functional Description
7	FERRI	Errored Framing Alignment Signal Interrupt. When unmasked this interrupt bit goes high whenever an erroneous bit in frame alignment signal is detected (provided the circuit is in terminal frame sync). Reading this register clears this bit.
6	CRCERRI	CRC-4 Error Interrupt. When unmasked this interrupt bit goes high whenever a local CRC-4 error occurs. Reading this register clears this bit.
5	EBITI	Receive E-bit Error Interrupt. When unmasked this interrupt bit goes high upon detection of a wrong E-bit in multiframe. Reading this register clears this bit.
4	AIS16I	Alarm Indication Signal Interrupt. When unmasked this interrupt bit goes high whenever all ones in time slot 16 occur. Reading this register clears this bit.
3	LCVI	Bipolar Violation Interrupt. When unmasked this interrupt bit goes high whenever a line code violation (excluding HDB3 encoding) is encountered. Reading this register clears this bit.
2	PRBSERRI	Pseudo Random Bit Sequence Error Interrupt. When unmasked this interrupt bit goes high upon detection of an error with a channel selected for PRBS testing. Reading this register clears this bit.
1	AUXPI	Auxiliary Pattern Alarm Interrupt. When unmasked this interrupt bit goes high whenever a sequence of 512 bit consecutive 101010. occur. Reading this register clears this bit.
0	RAII	Remote alarm Indication Interrupt. When unmasked this interrupt bit goes high whenever the bit 3 of non-frame alignment signal is high. Reading this register clears this bit.

Table 143 - Interrupt Word One

(Page 4, Address 1CH) (E1)

Bit	Name	Functional Description
7	FERRO	Errored Framing Alignment Signal Counter Overflow Interrupt. When unmasked this interrupt bit goes high whenever the errored frame alignment signal counter changes from FFH to 00H. Reading this register clears this bit.
6	CRCO	CRC Error Counter Overflow Interrupt. When unmasked this interrupt bit goes high whenever the CRC error counter changes from FFH to 00H. Reading this register clears this bit.
5	- - -	Unused.
4	FEBO	E-bit Counter Overflow Interrupt. When unmasked this interrupt bit goes high whenever the E-bit counter changes from FFH to 00H. Reading this register clears this bit.
3	LCVO	Line Code Violation Counter Overflow Interrupt. When unmasked this interrupt bit goes high whenever the line code violation counter changes from FFH to 00H. Reading this register clears this bit.
2	PRBSO	Pseudo Random Bit Sequence Error Counter Overflow Interrupt. When unmasked this interrupt bit goes high whenever the PRBS error counter changes from FFH to 00H. Reading this register clears this bit.
1	PRBSMFO	Pseudo Random Bit Sequence Multiframe Counter Overflow Interrupt. When unmasked this interrupt bit goes high whenever the multiframe counter attached to the PRBS error counter overflows. FFH to 00H. 1 - unmasked, 0 - masked.
0	Sal	Sa Bit Interrupt. When unmasked this interrupt goes high whenever either a change of state of any of the received Sa bits Sa5, Sa6, Sa7 or Sa8 (SaBorNi = 1) or a change of state of any of the received Sa nibbles (SaBorNi = 0). The control bit SaBorNi is located in page 1 address 12H bit 4.

Table 144 - Interrupt Word Two

(Page 4, Address 1DH) (E1)

Bit	Name	Functional Description
7	HDLC0I	HDLC0 Interrupt. Whenever an unmasked HDLC0 interrupt occurs, this bit goes high. Reading this register clears this bit.
6	HDLC1I	HDLC1 Interrupt. Whenever an unmasked HDLC1 interrupt occurs, this bit goes high. Reading this register clears this bit.
5	HDLC2I	HDLC2 Interrupt. Whenever an unmasked HDLC2 interrupt occurs, this bit goes high. Reading this register clears this bit.
4	JAI	Jitter Attenuator Error Interrupt. Whenever an unmasked JAI interrupt occurs. If jitter attenuator FIFO comes within four bytes of an overflow or underflow, this bit goes high. Reading this register clears this bit.
3	1SECI	One Second Status Interrupt. When unmasked this interrupt bit goes high whenever the 1SEC status bit (page 3 address 12H bit 7) goes from low to high. Reading this register clears this bit.
2	5SECI	Five Second Status Interrupt. When unmasked this interrupt bit goes high whenever the 5 SEC status bit goes from low to high. Reading this register clears this bit.
1	RCRI	RCRI Interrupt. Whenever an unmasked RCRI interrupt occurs. If remote alarm and CRC error occur this bit goes high. Reading this register clears this bit.
0	SIGI	Signaling Interrupt. When unmasked this interrupt bit goes high whenever a change of state (optionally debounced - see DBEn in the Data Link, signaling Control Word) is detected in the signaling bits (AB or ABCD) pattern. Reading this register clears this bit.

Table 145 - Interrupt Word Three

(Page 4, Address 1EH) (E1)

Bit	Name	Functional Description
7	FERROL	Errorred Frame Alignment Signal Counter Overflow Latch. This bit is set when the errored frame alignment signal counter overflows. It is cleared after being read.
6	CRCOL	CRC Error Counter Overflow Latch. This bit is set when the crc error counter overflows. It is cleared after being read.
5	FEBEOL	E bit Counter Overflow Latch. This bit is set when E bit counter overflows. It is cleared after being read.
4	---	
3	LCVOL	Line Code Violation Counter Overflow Latch. This bit is set when the line code violation counter overflows. It is cleared after being read.
2	PRBSOL	Pseudo Random Bit Sequence Error Counter Overflow Latch. This bit is set when the PRBS error counter overflows. It is cleared after being read.
1	PRBSMFOL	Pseudo Random Bit Sequence Multiframe Counter Overflow Latch. This bit is set when the multiframe counter attached to the PRBS error counter overflows. It is cleared after being read
0	---	Unused.

Table 146 - Overflow Reporting Latch

(Page 4, Address 1FH) (E1)

21.2 Per Channel Transmit signaling (Pages 5 and 6) (E1)

Page 05H, addresses 10000 to 11111, and page 06H addresses 10000 to 10111 contain the Transmit signaling Control Words for Channel Associated signaling (CAS) channels 2 to 16 and 18 to 32 respectively. Table 147 illustrates the mapping between the addresses of these pages and the CAS channel numbers. Control of these bits for any one channel is through the processor or controller port when the Per Time Slot Control bit RPSIG bit is high. Table 148 describes bit allocation within each of these registers.

Page 5-6 Address:	0	1	2	3	4	5	6	7	8	9	10	11	12	13	14	15
Equivalent CAS channel	1	2	3	4	5	6	7	8	9	10	11	12	13	14	15	16
Page 6 Address:	0	1	2	3	4	5	6	7	8	9	10	11	12	13	14	15
Equivalent CAS channel	17	18	19	20	21	22	23	24	25	26	27	28	29	30	31	32

Table 147 - Page 5, 6 Address Mapping to CAS signaling Channels (E1)

Bit	Name	Functional Description
7 - 4	---	Unused.
3 - 0	A(n) B(n) C(n) D(n)	Transmit signaling Bits for Channel n. These bits are transmitted on the PCM 30 2048 kbit/sec. Link in bit positions one to four of time slot 16 in frame n (when n = 1 to 15), and are the A, B, C, D signaling bits associated with channel n.

Table 148 - Transmit Channel Associated Signalling (E1) (Pages 5 and 6)

Serial per channel transmit signaling control through CSTI is selected when RPSIG bit is zero. Table 149 describes the function of CSTI time slots 1 to 30. if MSN bit is high, CSTI time slots 17 to 31 are selected. if MSN bit is low, CSTI time slots 1 to 15 are selected.

Bit	Name	Functional Description
7 - 4	A(n), B(n), C(n), D(n)	Transmit signaling Bits for Channel n. These bits are transmitted on the PCM 30 2048 kbit/sec. Link in bit positions one to four of time slot 16 in frame n (where n = 1 to 15), and are the A, B, C, D signaling bits associated with channel n.
3 - 0	A(n), B(n), C(n), D(n)	Transmit signaling Bits for Channel n. These bits are transmitted on the PCM 30 2048 kbit/sec. Link in bit positions one to four of time slot 16 in frame n (where n = 1 to 15), and are the A, B, C, D signaling bits associated with channel n.

Table 149 - E1 / Transmit Channels Usage - CSTI

NOTE: This table illustrates bit mapping on the serial input stream - it does not refer to an internal register.

21.3 Per Time Slot Control Words (Pages 7 and 8) (E1)

The control functions described by Table 151 are repeated for each PCM-30 channel. Page 07H addresses 10H to 1FH correspond to time slots 0 to 15, while page 08H addresses 10H to 1FH correspond to time slots 16 to 31. Table 150 illustrates the mapping between the addresses of these pages and the CEPT channel numbers.

Page 8H Address:	0	1	2	3	4	5	6	7	8	9	10	11	12	13	14	15
Equivalent PCM 30 Timeslots	0	1	2	3	4	5	6	7	8	9	10	11	12	13	14	15
Page 9H Address:	0	1	2	3	4	5	6	7	8	9	10	11	12	13	14	15
Equivalent PCM 30 Timeslots	16	17	18	19	20	21	22	23	24	25	26	27	28	29	30	31

Table 150 - Mapping between the addresses of these pages and the CEPT channel numbers

Bit	Name	Functional Description
7	TXMSG	Transmit Message Mode. If high, the data from the corresponding address location of Tx message mode buffer is transmitted in the corresponding PCM 30 time slot. If zero, the data on DSTI is transmitted on the corresponding PCM 30 time slot.
6	ADI	Alternate Digit Inversion. If one, the corresponding transmit time slot data on DSTI has every second bit inverted. If zero, this bit has no effect on channel data.
5	RTSL	Remote Time Slot Loopback. If one, the corresponding PCM 30 receive time slot is looped to the corresponding PCM 30 transmit timeslot. This received time slot will also be present on DSTO. If zero, the loopback is disabled.
4	LTSL	Local Time Slot Loopback. If one, the corresponding transmit time slot is looped to the corresponding receive time slot. This transmit time slot will also be present on the transmit PCM 30 stream. If zero, this loopback is disabled.
3	TTST	Transmit Test. If one, a test signal, either digital milliwatt (when control bit ADSEQ is one) or PRBS ($2^{15}-1$) (ADSEQ is zero), will be transmitted in the corresponding PCM 30 time slot. More than one time slot may be activated at once. If zero, the test signal will not be connected to the corresponding time slot.
2	RTST	Receive Test. If one, the corresponding DSTo time slot will be used for testing. If control bit ADSEQ is one, a digital milliwatt signal will be transmit onto the DSTo channel. If ADSEQ is zero the receive channel will be connected to the PRBS detector ($2^{15}-1$).
1	RPSIG	Serial Signaling Enable. If one, the transmit CAS signaling will be controlled by programming Page 05H. If zero, the transmit CAS signaling will be controlled through the CSTI stream.
0	---	Unused.

Table 151 - Per Time Slot Control Words (Pages 7 and 8) (E1)

21.4 Per Channel Receive signaling (Pages 9 and 0AH) (E1)

Page 09H, addresses 10001 to 11111, and page 0AH addresses 10001 to 11111 contain the Receive signaling Control Words for CAS channels 2 to 16 and 18 to 32. Table 153 illustrates the mapping between the addresses of these pages and the CAS channel numbers. Table 154 describes bit allocation within each of these registers.

Page 9 Address:	0	1	2	3	4	5	6	7	8	9	10	11	12	13	14	15
Equivalent PCM 30 Timeslots	0	1	2	3	4	5	6	7	8	9	10	11	12	13	14	15
Page A Address:	0	1	2	3	4	5	6	7	8	9	10	11	12	13	14	15
Equivalent PCM 30 Timeslots	16	17	18	19	20	21	22	23	24	25	26	27	28	29	30	31

Table 152 - Page 9 and A Address Mapping to CAS Channels (E1)

Bit	Name	Functional Description
7 - 4	---	Unused
3 - 0	A(n) B(n) C(n) D(n)	Receive signaling Bits for Channel n. These bits are received on the PCM 30 2048 kbit/sec. Link in bit positions one to four of time slot 16 in frame n (where n = 1 to 30) and are the A, B, C, D signaling bits associated with channel n.

Table 153 - Receive Channel Associated signaling (Pages 9 and A) (E1)

Serial per channel receive signaling status bits appear on ST-BUS stream CSTo. Table 157 describes the bit allocation within each of the 30 active ST-BUS time slot of CSTo.

Bit	Name	Functional Description
7 - 4	A(n), B(n), C(n), D(n)	Transmit signaling Bits for Channel n. These bits are transmitted on the PCM 30 2048 kbit/sec. Link in bit positions one to four of time slot 16 in frame n (where n = 1 to 15), and are the A, B, C, D signaling bits associated with channel n.
3 - 0	A(n), B(n), C(n), D(n)	Transmit signaling Bits for Channel n. These bits are transmitted on the PCM 30 2048 kbit/sec. Link in bit positions one to four of time slot 16 in frame n (where n = 1 to 15), and are the A, B, C, D signaling bits associated with channel n.

Table 154 - Receive CAS Channels (CSTo) (E1)

22.0 HDLC Control and Status

(Page B for HDLC0, Page C for HDLC1 and Page D for HDLC2)

Address	Register		Function
	Control (Write/Verify)	Status (Read)	
10H (Table 156)	Address Recognition 1	- - -	ADR16-10,A1EN
11H (Table 157)	Address Recognition 2	- - -	ADR26-20, A2EN
12H (Table 158/Table 159)	TX FIFO	RX FIFO	BIT7-0
13H (Table 160)	HDLC Control 1	- - -	ADREC, RxEN, TxEN, EOP, FA, Mark-idle, TR, FRUN
14H (Table 161)	- - -	HDLC Status	INTGEN, Idle-Chan, RQ9, RQ8, TxSTAT2, TxSTAT1, RxSTAT2, RxSTAT1
15H (Table 162)	HDLC Control 2	- - -	INTSEL, CYCLE, TxCRCl, SEVEN, RxFRST, TxFRST
16H (Table 163)	Interrupt Mask	- - -	GaIM, RxEOPIM, TxEOPIM, RxFEIM, TxFLIM, FA:TxUNDERIM, RxFFIM, RxOVFIM
17H (Table 164)	- - -	Interrupt Status (*)	Ga, RxEOP, TxEOP, RxFE, TxFL, FA:TxUNDER, RxFF, RxOVF
18H (Table 165)	- - -	Rx CRC MSB	CRC15-CRC8
19H (Table 166)	- - -	Rx CRC LSB	CRC7-CRC0
1AH (Table 167)	Low TX byte count	- - -	TxCNT7-0
1BH (Table 168)	Test Control	- - -	HRST, RTLOOP, CRCTST, FTST, ARTST, HLOOP
1CH (Table 169)	- - -	Test Status	RxCLK, TxCLK, VCRC, VADDR
1DH (Table 170)	HDLC Control 3	- - -	RSV, RFD2-0,RSV, TFD2-0
1EH (Table 171)	HDLC Control 4	- - -	RSV, RFFS2-0, RSV, TFLS2-0
1FH (Table 172)	Extended TX byte count	- - -	TxCNT15-8

Table 155 - HDLC0, HDLC1, HDLC2 Control and Status (Pages B, C, and D)

Bit	Name	Functional Description
7 - 2	ADR16-11	Address 16 - 11. A six bit address used for comparison with the first byte of the received address. ADR16 is MSB.
1	ADR10	Address 10. This bit is used in address comparison if a seven bit address is being checked for (control bit four of control register 2 is set).
0	A1EN	First Address Comparison Enable. When this bit is high, the above six (or seven) bit address is used in the comparison of the first address byte. If address recognition is enabled, any packet failing the address comparison will not be stored in the RX FIFO. A1EN must be high for All-call (111111) address recognition for single byte address. When this bit is low, this bit mask is ignored in address comparison

Table 156 - HDLC Address Recognition Register 1

(Pages B, C, and D, Address 10H)

Bit	Name	Functional Description
7 - 1	ADR26-20	Address 26 - 20. A seven bit address used for comparison with the second byte of the received address. ADR26 is MSB. This mask is ignored (as well as first byte mask) if all call address (111111) is received.
0	A2EN	Second Address Comparison Enable. When this bit is set high, the above seven bit address is used in the comparison of the second address byte. If address recognition is enabled, any packet failing the address comparison will not be stored in the RX FIFO. A2EN must be high for All-call address recognition. When this bit is low, this bit mask is ignored in address comparison.

Table 157 - HDLC Address Recognition Register 2

(Pages B,C, and D, Address 11H)

Bit	Name	Functional Description
7 - 0	BIT7-0	This eight bit word is tagged with the two status bits from the control register 1 (EOP and FA), and the resulting 10 bit word is written to the TX FIFO. The FIFO status is not changed immediately after a write or read occurs. It is updated after the data has settled and the transfer to the last available position has finished.

Table 158 - TX FIFO Write Register

(Pages B, C, and D, Address 12H)

Bit	Name	Functional Description
7 - 0	BIT7-0	This is the received data byte read from the RX FIFO. The status bits of this byte can be read from the status register. The FIFO status is not changed immediately when a write or read occurs. It is updated after the data has settled and the transfer to the last available position has finished.

Table 159 - RX FIFO Read Register

(Pages B, C, and D, Address 12H)

Bit	Name	Functional Description
7	ADREC	Address Recognition. When high this bit will enable address recognition. This forces the receiver to recognize only those packets having the unique address as programmed in the Receive Address Recognition Registers or if the address is an All call address.
6	RxEN	Receive Enable. When low this bit will disable the HDLC receiver. The receiver will disable after the rest of the packet presently being received is finished. The receiver internal clock is disabled. When high the receiver will be immediately enabled and will begin searching for flags, Go-aheads etc.
5	TxEN	Transmit Enable. When low this bit will disable the HDLC transmitter. The transmitter will disable after the completion of the packet presently being transmitted. The transmitter internal clock is disabled. When high the transmitter will be immediately enabled and will begin transmitting data, if any, or go to a mark idle or interframe time fill state.
4	EOP	End of Packet. Forms a tag on the next byte written the TX FIFO, and when set will indicate an end of packet byte to the transmitter, which will transmit an FCS following this byte. This facilitates loading of multiple packets into TX FIFO. Reset automatically after a write to the TX FIFO occurs.
3	FA	Frame Abort. Forms a tag on the next byte written to the TX FIFO, and when set will indicate to the transmitter that it should abort the packet in which that byte is being transmitted. Reset automatically after a write to the TX FIFO.
2	Mark-Idle	Mark - Idle. When low, the transmitter will be in an idle state. When high it is in an interframe time fill state. These two states will only occur when the TX FIFO is empty.
1	TR	Transparent Mode. When high this bit will enable transparent mode. This will perform the parallel to serial conversion without inserting or deleting zeros. No CRC bytes are sent or monitored nor are flags or aborts. A falling edge of TxEN for transmit and a falling edge of RxEN for receive is necessary to initialize transparent mode. This will also synchronize the data to the transmit and receive channel structure. Also, the transmitter must be enabled through control register 1 before transparent mode is entered.
0	FRUN	Freerun. When high the HDLC TX and RX are continuously enabled providing the RxEN and TxEN bits are set.

Table 160 - HDLC Control Register 1**(Pages B, C, and D, Address 13H)**

Bit	Name	Functional Description
7	INTGEN	Interrupt Generated. Set to 1 when an interrupt (in conjunction with the Interrupt Mask Register) has been generated by the HDLC. This is an asynchronous event. It is reset when the interrupt Register is read.
6	Idle Chan	Idle Channel. Set to a 1 when an idle Channel state (15 or more ones) has been detected at the receiver. This is an asynchronous event. On power reset, this may be 1 if the clock (RXC) was not operating. Status becomes valid after the first 15 bits or the first zero is received.
5 - 4	RQ9, RQ8	Byte Status bits from RX FIFO. These bits determine the status of the byte to be read from RX FIFO as follows: RQ9 RQ8 Byte Status 0 0 Packet Byte 0 1 First Byte 1 0 Last byte of a good packet. 1 1 Last byte of a bad packet.
3 - 2	TxSTAT2-1	These bits determine the status of the TX FIFO as follows: TxSTAT2 TxSTAT1 TX FIFO Status 0 0 TX FIFO full up to the selected status level or more. 0 1 The number of bytes in the TX FIFO has reached or exceeded the selected interrupt threshold level. 1 0 TX FIFO empty. 1 1 The number of bytes in the TX FIFO is less than the selected interrupt threshold level.
1 - 0	RxSTAT2 - 1	These bits determine the status of the RX FIFO as follows: RxSTAT2 RxSTAT1 RX FIFO Status 0 0 RX FIFO empty 0 1 The number of bytes in the RX FIFO is less than the interrupt threshold level. 1 0 RX FIFO full. 1 1 The number of bytes in the RX FIFO has reached or exceeded the interrupt threshold level.

Table 161 - HDLC Status Register

(Pages B, C, and D Address 14H)

Bit	Name	Functional Description
7	INTSEL	Interrupt Selection. When high, this bit will cause bit 2 of the Interrupt Register to reflect a TX FIFO underrun (TXunder). When low, this interrupt will reflect a frame abort (FA).
6	CYCLE	Cycle. When high, this bit will cause the transmit byte count to reload one minus the value initially loaded into the Transmit Byte Count Register.
5	TxCRCI	Transmit CRC Inhibited. When high, this bit will inhibit transmission of the CRC. That is, the transmitter will not insert the computed CRC onto the bit stream after seeing the EOP tag byte. This is used in V.120 terminal adaptation for synchronous protocol sensitive UI frames.
4	SEVEN	Seven Bit Address Recognition. When high, this bit will enable seven bits of address recognition in the first address byte. The received address byte must have bit 0 equal to 1 which indicates a single address byte is being received.
3	--	Reserved, must be zero for normal operation.
2	--	Reserved, must be zero for normal operation.
1	RxFRST	RX FIFO Reset. When high, the RX FIFO will be reset. This causes the receiver to be disabled until the next reception of a flag. The status register will identify the FIFO as being empty. However, the actual bit values in the RX FIFO will not be reset.
0	TxFRST	TX FIFO Reset. When high, the TX FIFO will be reset. The Status Register will identify the FIFO as being empty. This bit will be reset when data is written to the TX FIFO. However, the actual bit values of data in the TX FIFO will not be reset. It is cleared by the next write to the TX FIFO.

Table 162 - HDLC Control Register 2
(Pages B, C, and D, Address 15H)

Bit	Name	Functional Description
7-0	GalM RxEOPI M TxEOPI M RxFEIM TxFLIM FA:TxUNDERRIM RxFFIM RxOVFIM	This register is used with the Interrupt Register to mask out the interrupts that are not required by the microprocessor. Interrupts that are masked out will not drive the pin IRQ low; however, they will set the appropriate bit in the Interrupt Register. An interrupt is disabled when the microprocessor writes a 0 to a bit in this register. This register is cleared on power reset.

Table 163 - HDLC Interrupt Mask Register
(Pages B, C, and D, Address 16H)

Bit	Name	Functional Description
7	GA	Go Ahead. Indicates a go-ahead pattern was detected by the HDLC receiver. This bit is reset after a read.
6	RxEOP	End Of Packet Detected. This bit is set when an end of packet (EOP) byte was written into the RX FIFO by the HDLC receiver. This can be in the form of a flag, an abort sequence or as an invalid packet. This bit is reset after a read.
5	TxEOP	Transmit End Of Packet. This bit is set when the transmitter has finished sending the closing flag of a packet or after a packet has been aborted. This bit is reset after read.
4	RxFE	End Of Packet Read. This bit is set when the byte about to be read from the RX FIFO is the last byte of the packet. It is also set if the Rx FIFO is read and there is no data in it. This bit is reset after a read.
3	TXFL	TX FIFO Low. This bit is set when the Tx FIFO is emptied below the selected low threshold level. This bit is reset after a read.
2	FA: TxUNDER	Frame Abort/TX FIFO Underrun. When Intsel bit of Control Register 2 is low, this bit (FA) is set when a frame abort is received during packet reception. It must be received after a minimum number of bits have been received (26) otherwise it is ignored. When INTSEL bit of Control Register 2 is high, this bit is set for a TX FIFO underrun indication. If high it indicates that a read by the transmitter was attempted on an empty Tx FIFO. This bit is reset after a read.
1	RXFF	RX FIFO Full. This bit is set when the Rx FIFO is filled above the selected full threshold level. This bit is reset after a read.
0	RxOVF	RX FIFO Overflow. Indicates that the 128 byte RX FIFO overflowed (i.e., an attempt to write to a 128 byte full RX FIFO). The HDLC will always disable the receiver once the receive overflow has been detected. The receiver will be re-enabled upon detection of the next flag, but will overflow again unless the RX FIFO is read. This bit is reset after a read.

Table 164 - HDLC Interrupt Status Register
(Pages B, C, and D, Address 17H)

Bit	Name	Functional Description
7-0	CRC15-8	The MSB byte of the CRC received from the transmitter. These bits are as the transmitter sent them; that is, most significant bit first and inverted. This register is updated at the end of each received packet and therefore should be read when end of packet is detected.

Table 165 - Receive CRC MSB Register
(Pages B, C, and D, Address 18H)

Bit	Name	Functional Description
7-0	CRC7-0	The LSB byte of the CRC received from the transmitter. These bits are as the transmitter sent them; that is, most significant bit first and inverted. This register is updated at the end of each received packet and therefore should be read when end of packet is detected.

Table 166 - Receive CRC LSB Register
(Pages B, C, and D, Address 19H)

Bit	Name	Functional Description
7-0	TxCNT7-0	Low Transmit Byte Count Register. This register, along with the Extended Transmit Byte Count Register indicates the length of the packet about to be transmitted. For a packet size of 255 or less it is only necessary to write this register. When this register reaches the count of one, the next write to the Tx FIFO will be tagged as an end of packet byte. The counter decrements at the end of the write to the Tx FIFO. If the Cycle bit of Control Register 2 is set high, the counter will cycle through the programmed value continuously.

Table 167 - Low Transmit Byte Count Register
(Pages B, C, and D, Address 1AH)

Bit	Name	Functional Description
7	HRST	HDLC Reset. When this bit is set to one, the HDLC will be reset. This is similar to RESET being applied, the only difference being that this bit will not be reset. This bit can only be reset by writing a zero twice to this location or applying RESET.
6	RTLOOP	RT Loopback. When this bit is high, receive to transmit HDLC loopback will be activated. Receive data, including end of packet indication, but not including flags or CRC, will be written to the TX FIFO as well as the RX FIFO. When the transmitter is enabled, this data will be transmitted as though written by the microprocessor. Both good and bad packets will be looped back. Receive to transmit loopback may also be accomplished by reading the RX FIFO using the microprocessor and writing these bytes, with appropriate tags, into the TX FIFO.
5	--	Reserved. Must be set to 0 for normal operation.
4	--	Reserved. Must be set to 0 for normal operation.
3	CRCTST	CRC Remainder Test. This bit allows direct access to the CRC Comparison Register in the receiver through the serial interface. After testing is enabled, serial data is clocked in until the data aligns with the internal comparison (16 RXC clock cycles) and then the clock is stopped. The expected pattern is F0B8 hex. Each bit of the CRC can be corrupted to allow more efficient testing.
2	FTST	FIFO Test. This bit allows the writing to the RX FIFO and reading of the TX FIFO through the microprocessor to allow more efficient testing of the FIFO status/interrupt functionality. This is done by making a TX FIFO write become a RX FIFO write and a RX FIFO read become a TX FIFO read. In addition, EOP/FA and RQ8/RQ9 are re-defined to be accessible (i.e., RX write causes EOP/FA to go to RX fifo input; TX read looks at output of TX fifo through RQ8/RQ9 bits).
1	ARTST	Address Recognition Test. This bit allows direct access to the Address Recognition Registers in the receiver through the serial interface to allow more efficient testing. After address testing is enabled, serial data is clocked in until the data aligns with the internal address comparison (16 RXc clock cycles) and then clock is stopped.
0	HLOOP	TR Loopback. When high, transmit to receive HDLC loopback will be activated. The packetized transmit data will be looped back to the receive input. RXEN and TXEN bits must also be enabled.

Table 168 - HDLC Test Control Register

(Pages B, C, and D, Address 1BH)

Bit	Name	Functional Description
7-4	--	These bits are reserved.
3	RxCLK	Receive Clock. This bit represents the receiver clock generated after the RXEN control bit, but before zero deletion is considered.
2	TxCLK	Transmit Clock. This bit represents the transmit clock generated after the TXEN control bit, but before zero insertion is considered.
1	VCRC	Valid CRC. This is the CRC recognition status bit for the receiver. Data is clocked into the register and then this bit is monitored to see if comparison was successful (bit will be high).
0	VADDR	Valid Address. This is the address recognition status bit for the receiver. Data is clocked into the Address Recognition Register and then this bit is monitored to see if comparison was successful (bit will be high).

Table 169 - HDLC Test Status Register

(Pages B, C, and D, Address 1CH)

Bit	Name	Functional Description			
7	---	Unused.			
6-4	RFD2-0	These bits select the Rx FIFO full status level:			
		RFD2	RFD1	RFD0	Full Status Level
		0	0	0	16
		0	0	1	32
		0	1	0	48
		0	1	1	64
		1	0	0	80
		1	0	1	96
		1	1	0	112
1	1	1	128		
3	---	Unused.			
2-0	TFD2-0	These bits select the Tx HDLC FIFO full status level:			
		TFD2	TFD1	TFD0	Full Status Level
		0	0	0	16
		0	0	1	32
		0	1	0	48
		0	1	1	64
		1	0	0	80
		1	0	1	96
		1	1	0	112
1	1	1	128		

Table 170 - HDLC Control Register 3
(Pages B, C, and D, Address 1DH)

Bit	Name	Functional Description			
7	--	Unused.			
6-4	RFFS2-0	These bits select the RXFF (Rx FIFO Full) interrupt threshold level:			
		RFFS2	RFFS1	RFFS0	RX FIFO Full Interrupt threshold Level.
		0	0	0	64
		0	0	1	72
		0	1	0	80
		0	1	1	88
		1	0	0	96
		1	0	1	104
		1	1	0	112
1	1	1	120		
3	--	Unused.			
2-0	TFLS2-0	These bits select the TXFL (Tx FIFO Low) interrupt threshold level:			
		TFLS2	TFLS1	TFLS0	TX FIFO Low Interrupt threshold Level.
		0	0	0	8
		0	0	1	16
		0	1	0	24
		0	1	1	32
		1	0	0	40
		1	0	1	48
		1	1	0	56
1	1	1	64		

Table 171 - HDLC Control Register 4

(Pages B, C, and D, Address 1EH)

Bit	Name	Functional Description
7-0	TxCNT15-8	Extended Transmit Byte Count Register. This register, along with the Transmit Byte Count Register indicates the length of the packet about to be transmitted. Values programmed into this register are not internally updated until the next write to the Low Transmit Byte Count Register. When the internal counter decrements to one, the next write to the Tx FIFO will be tagged as an end of packet byte. The counter decrements at the end of the write to the Tx FIFO. If the Cycle bit of Control Register 2 is set high, the counter will cycle through the programmed value continuously.

Table 172 - Extended Transmit Byte Count Register

(Pages B,C, and D, Address 1FH)

23.0 Transmit National Bit Buffer (Page 0EH)

Page 0EH, address 10H to 14H contain the five bytes of the transmit national bit buffer (TNBB0 - TNBB4 respectively). This feature is functional only when control bit NBTB (page 01H, address 17H) is one.

Bit	Name	Functional Description
7 - 0	TNBBn.F1 - TNBBn.F15	Transmit S_{an+4} Bits Frames 1 to 15. This byte contains the bits transmitted in bit position n+4 of channel zero of frames 1, 3, 5, 7, 9, 11, 13 and 15 when CRC-4 multiframe alignment is used, or of consecutive odd frames when CRC-4 multiframe alignment is not used. n = 0 to 4 inclusive and corresponds to a byte of the receive national bit buffer.

Table 173 - Transmit National Bit Buffer Bytes Zero to Four (Page 0EH)

24.0 Receive National Bit Buffer (Page 0FH)

Page 0FH, addresses 10H to 14H contain the five bytes of the receive national bit buffer (RNBB0 - RNBB4 respectively).

Bit	Name	Functional Description
7 - 0	RNBBn.F1 - RNBBn.F15	Receive S_{an+4} Bits Frames 1 to 15. This byte contains the bits received in bit position n+4 of channel zero of frames 1, 3, 5, 7, 9, 11, 13 and 15 when CRC-4 multiframe alignment is used, or of consecutive odd frames when CRC-4 multiframe alignment is not used. n = 0 to 4 inclusive and corresponds to a byte of the receive national bit buffer.

Table 174 - Receive National Bit Buffer Bytes Zero to Four (Page 0FH)

25.0 AC/DC Electrical Characteristics

Absolute Maximum Ratings* - Voltages are with respect to ground (V_{SS}) unless otherwise stated.

	Parameter	Symbol	Min.	Max.	Units
1	Supply Voltage	V_{DD}	-0.3	7	V
2	Voltage at Digital Inputs	V_I	-0.3	$V_{DD} + 0.3$	V
3	Current at Digital Inputs	I_I		30	mA
4	Voltage at Digital Outputs	V_O	-0.3	$V_{DD} + 0.3$	V
5	Current at Digital Outputs	I_O		30	mA
6	Storage Temperature	T_{ST}	-65	150	°C

* Exceeding these values may cause permanent damage. Functional operation under these conditions is not implied.

Recommended Operating Conditions - Voltages are with respect to ground (V_{SS}) unless otherwise stated.

	Characteristics	Sym.	Min.	Typ.‡	Max.	Units	Test Conditions
1	Operating Temperature	T_{OP}	-40		85	°C	
2	Supply Voltage	V_{DD}	3.0	3.3	3.6	V	

‡ Typical figures are at 25°C and are for design aid only: not guaranteed and not subject to production testing.

DC Electrical Characteristics† - Voltages are with respect to ground (V_{SS}) unless otherwise stated.

	Characteristics	Sym.	Min.	Typ.‡	Max.	Units	Test Conditions
1	Supply Current	I_{DD}		85	98	mA	Outputs unloaded. Transmitting an all 1's signal.
2	Input High Voltage (Digital Inputs)	V_{IH}	2.0		V_{DD}	V	
3	Input Low Voltage (Digital Inputs)	V_{IL}	0		0.8	V	
4	Input Leakage (Digital Inputs)	I_{IL}		1	12*	μA	$V_I = 0$ to V_{DD}
5	Output High Voltage (Digital Outputs)	V_{OH}	$0.8V_{DD}$		V_{DD}	V	$I_{OH} = 7$ mA, $V_{OH} = 2.4$ V
6	Output Low Voltage (Digital Outputs)	V_{OL}	V_{SS}		0.4	V	$I_{OL} = 2$ mA, $V_{OL} = 0.4$ V
7	High Impedance Leakage (Digital I/O)	I_{OZ}		1	12	μA	$V_O = 0$ to V_{DD}

† Characteristics are for clocked operation over the ranges of recommended operating temperature and supply voltage.

‡ Typical figures are at 25°C and are for design aid only: not guaranteed and not subject to production testing.

30 μA for inputs of boundary scan test port: Osc1, Tdi, Tms, Tclk and Trst.

AC Electrical Characteristics[†] - Motorola Microprocessor Timing

	Characteristics	Sym.	Min.	Typ. [‡]	Max.	Units	Test Conditions
1	DS low	t_{DSL}	70			ns	
2	DS High	t_{DSH}	60			ns	
3	\overline{CS} Setup	t_{CSS}	0			ns	
4	R/ \overline{W} Setup	t_{RWS}	1			ns	
5	Address Setup	t_{ADS}	4			ns	
6	\overline{CS} Hold	t_{CSH}	0			ns	
7	R/ \overline{W} Hold	t_{RWH}	7			ns	
8	Address Hold	t_{ADH}	4			ns	
9	Data Delay Read	t_{DDR}			75	ns	$C_L=50$ pF
10	Data Hold Read	t_{DHR}			75	ns	$C_L=50$ pF
11	Data Active to High Z Delay	t_{DAZ}			75	ns	
12	Data Setup Write	t_{DSW}	7			ns	
13	Data Hold Write	t_{DHW}	9			ns	

[†] Characteristics are for clocked operation over the ranges of recommended operating temperature and supply voltage.
[‡] Typical figures are at 25°C and are for design aid only: not guaranteed and not subject to production testing.

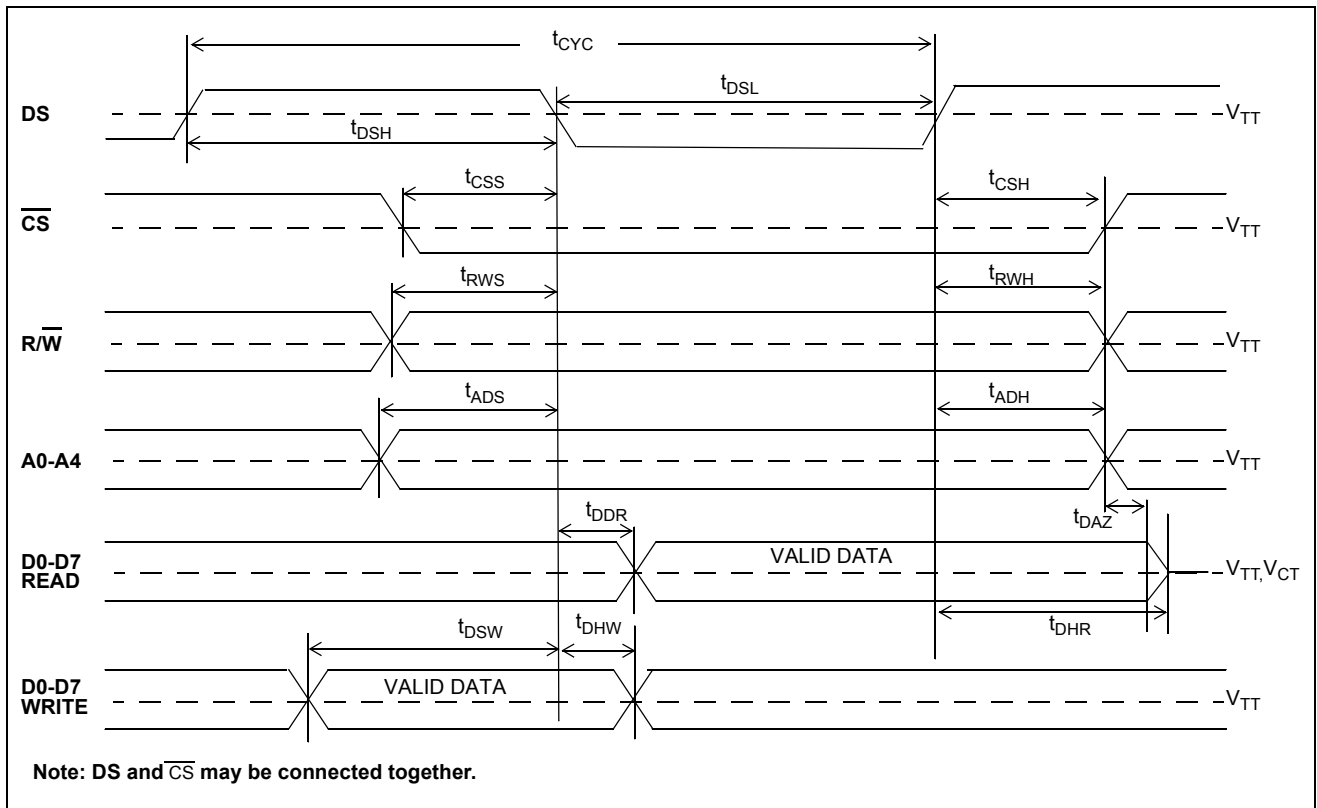

Figure 15 - Motorola Microport Timing

AC Electrical Characteristics[†] - Intel Microprocessor Timing

	Characteristics	Sym.	Min.	Typ. [‡]	Max.	Units	Test Conditions
1	RD low	$t_{RD\text{L}}$	70			ns	
2	RD High	$t_{RD\text{H}}$	60			ns	
3	$\overline{\text{CS}}$ Setup	t_{CSS}	0			ns	
4	$\overline{\text{CS}}$ Hold	t_{CSH}	0			ns	
5	Address Setup	t_{ADS}	4			ns	
6	Address Hold	t_{ADH}	4			ns	
7	Data Delay Read	t_{DDR}			75	ns	$C_L=50\text{ pF}$
8	Data Active to High Z Delay	t_{DAZ}			75	ns	
9	Data Setup Write	t_{DSW}	7			ns	
10	Data Hold Write	t_{DHW}	9			ns	

[†]Typical figures are at 25°C and are for design aid only; not guaranteed and not subject to production testing.

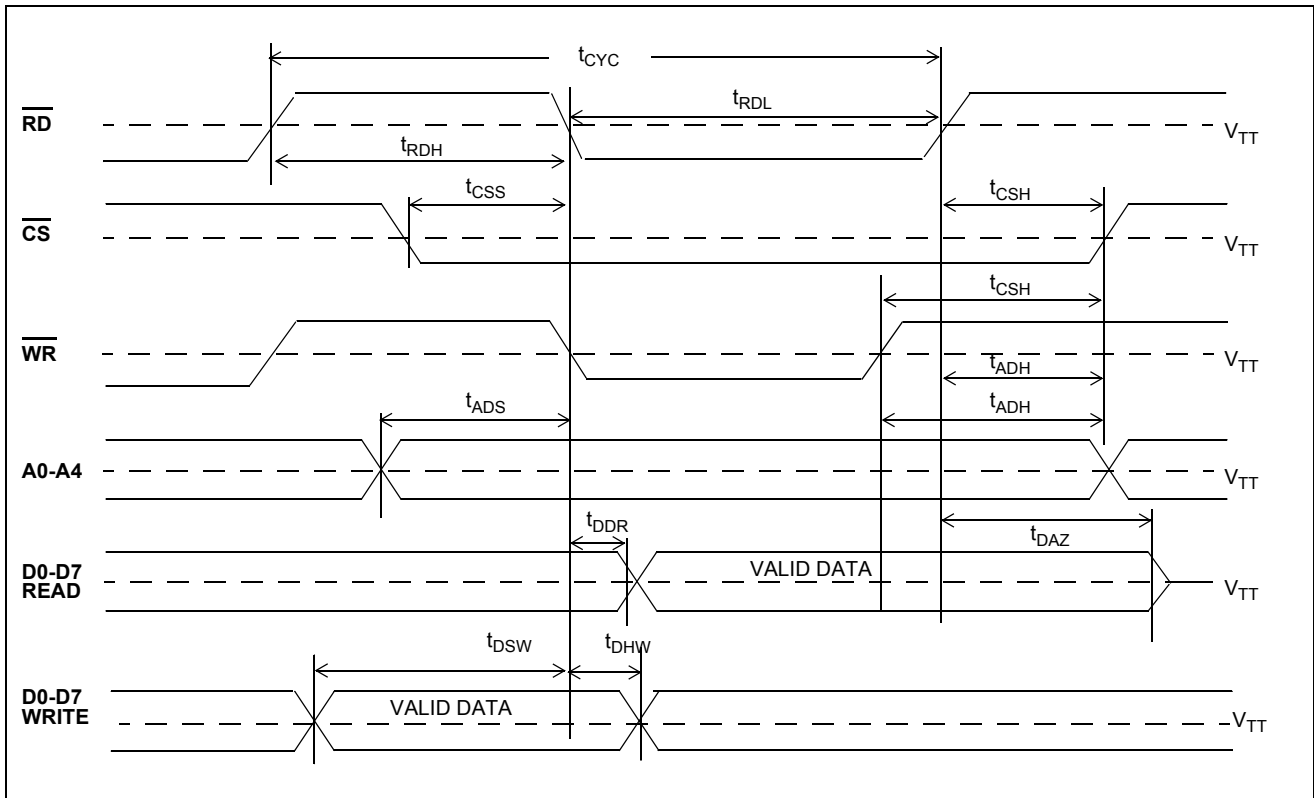

Figure 16 - Intel Microport Timing

AC Electrical Characteristics - JTAG Port Timing

	Characteristic	Sym.	Min.	Typ.	Max.	Units	Test Conditions
1	TCK period width	t_{TCLK}	100			ns	BSDL spec's 12 MHz
2	TCK period width LOW	t_{TCLKL}	40			ns	
3	TCK period width HIGH	t_{TCLKH}	40			ns	
	TDI setup time to TCK rising	t_{DISU}	12				
	TDI hold time after TCK rising	t_{DIH}	12				
	TMS setup time to TCK rising	t_{MSSU}	12				
	TMS hold time after TCK rising	t_{MSH}	12				
	TDO delay from TCK falling	t_{DOD}			50		
	\overline{TRST} pulse width	t_{TRST}	25				

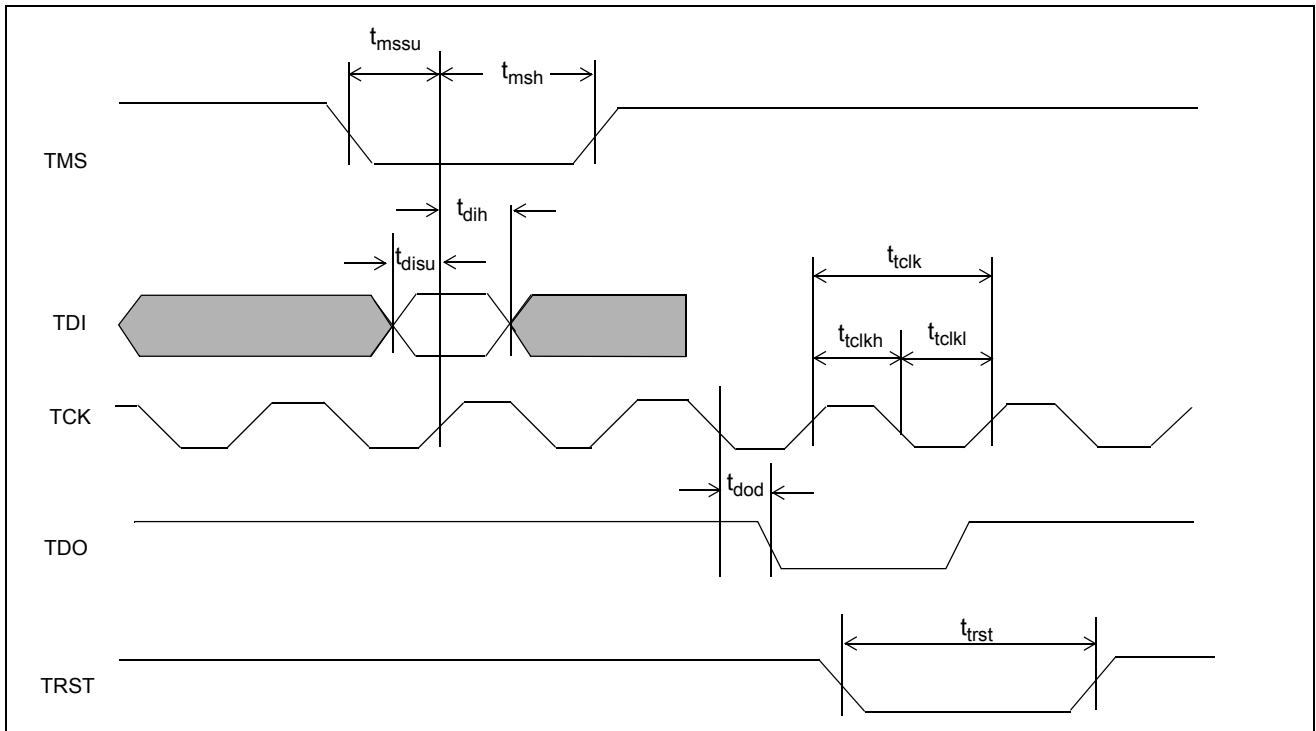

Figure 17 - JTAG Port Timing

AC Electrical Characteristics - Transmit Data Link Timing (T1 mode)

	Characteristic	Sym.	Min.	Typ.	Max.	Units	Test Conditions
1	Data Link Clock Pulse Width	t_{DW}		324		ns	150 pF
2	Data Link Setup	t_{TDS}	35			ns	
3	Data Link Hold	t_{TDH}	35			ns	

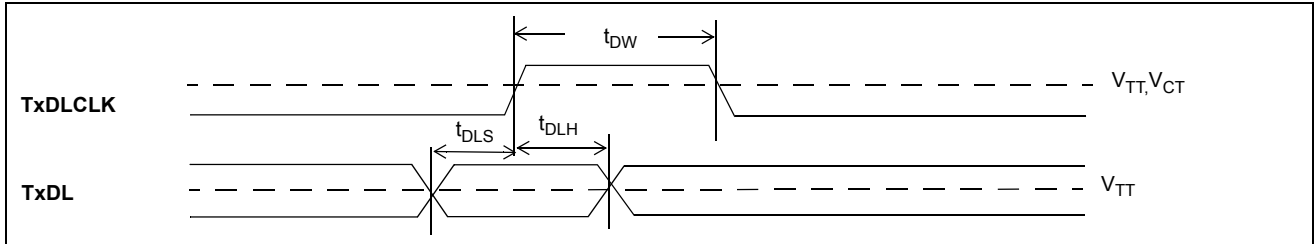

Figure 18 - Transmit Data Link Timing Diagram (T1 mode)

AC Electrical Characteristics - Transmit Data Link Timing (E1 mode)

	Characteristic	Sym.	Min.	Typ.	Max.	Units	Test Conditions
1	Data Link Clock Output Delay	t_{TDC}	72			ns	150 pF
2	Data Link Setup	t_{TDS}	35			ns	
3	Data Link Hold	t_{TDH}	35			ns	

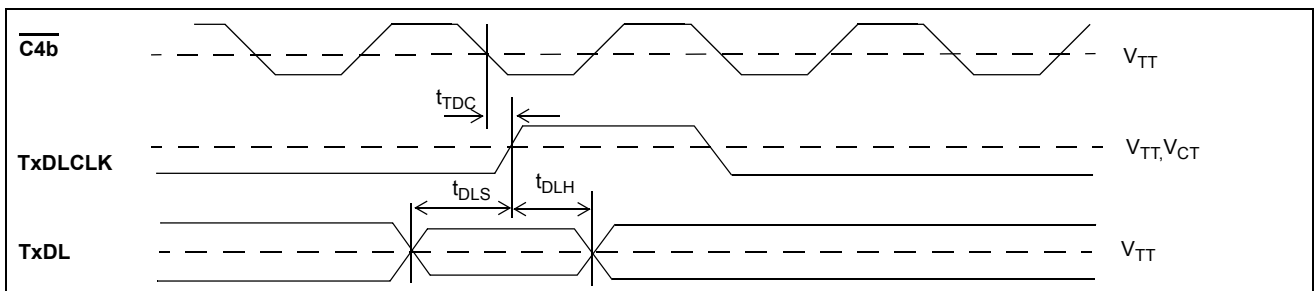

Figure 19 - Transmit Data Link Timing Diagram (E1 mode)

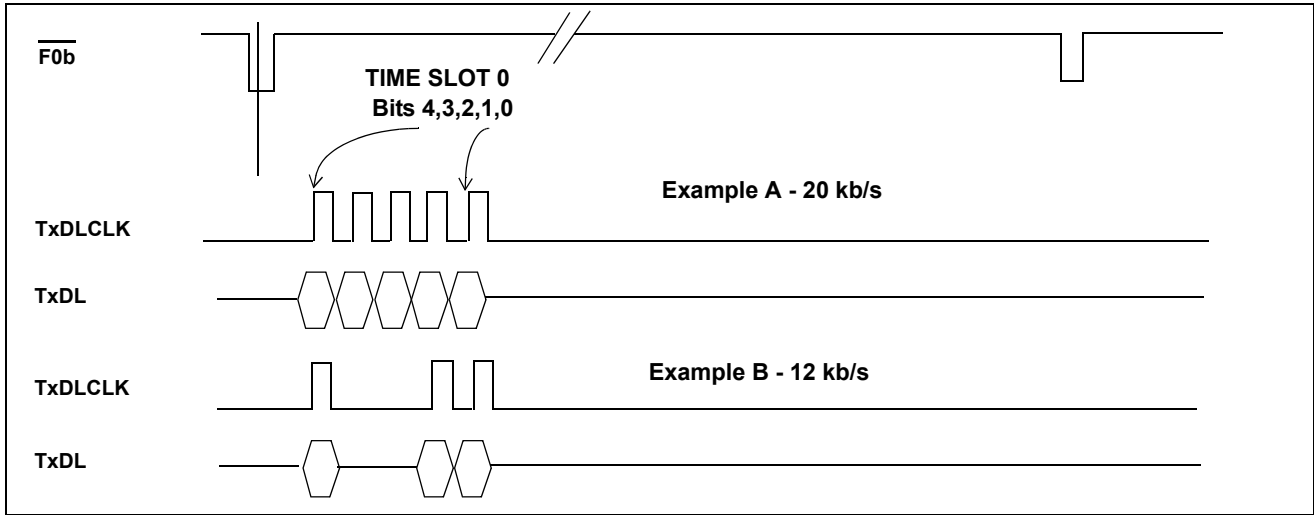

Figure 20 - Transmit Data Link Functional Timing (E1 mode)

AC Electrical Characteristics - Receive Data Link Timing (T1 mode)

	Characteristic	Sym.	Min.	Typ.	Max.	Units	Test Conditions
1	Data Link Clock Output Delay	t_{RDC}	160			ns	50 pF
2	Data Link Output Delay	t_{RDD}	45			ns	50 pF
3	RxFP Output Delay	t_{RFD}	45			ns	50 pF

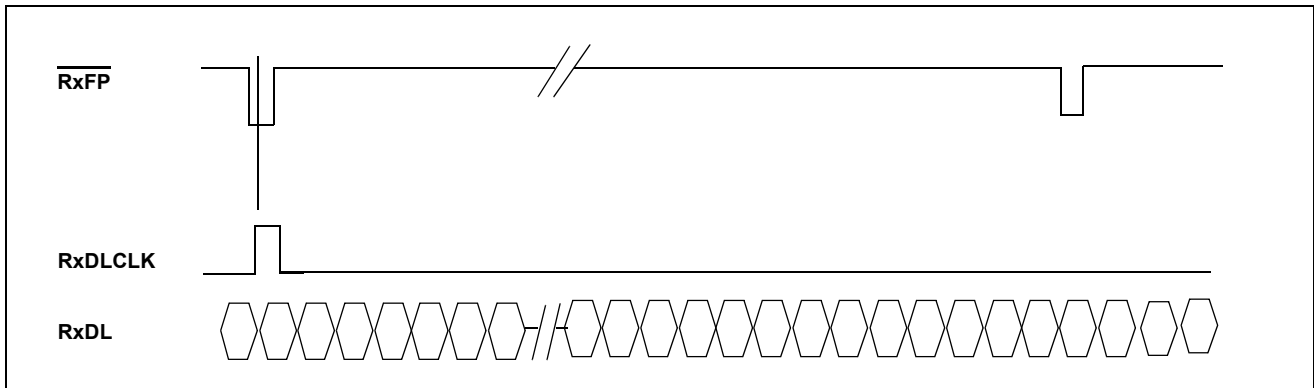

Figure 21 - Receive Data Link Functional Timing (T1 mode)

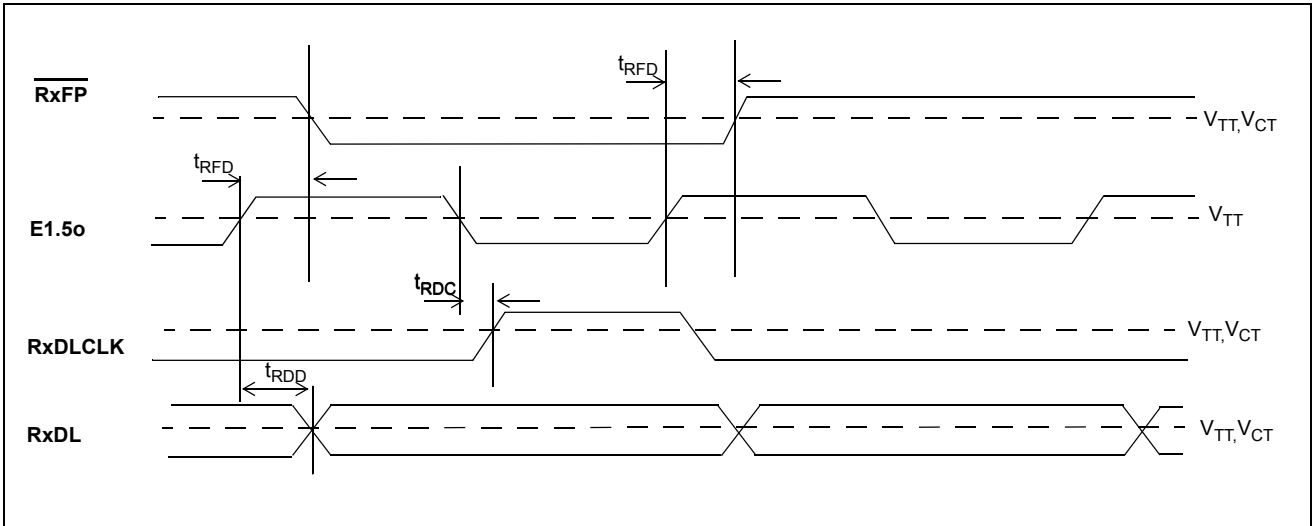

Figure 22 - Receive Data Link Diagram (T1 mode)

AC Electrical Characteristics - Receive Data Link Timing (E1 mode)

	Characteristic	Sym.	Min.	Typ.	Max.	Units	Test Conditions
1	Data Link Clock Output Delay	t_{RDC}	160			ns	50 pF
2	Data Link Output Delay	t_{RDD}	45			ns	50 pF
3	Rx̄FP Output Delay	t_{RFD}	45			ns	50 pF

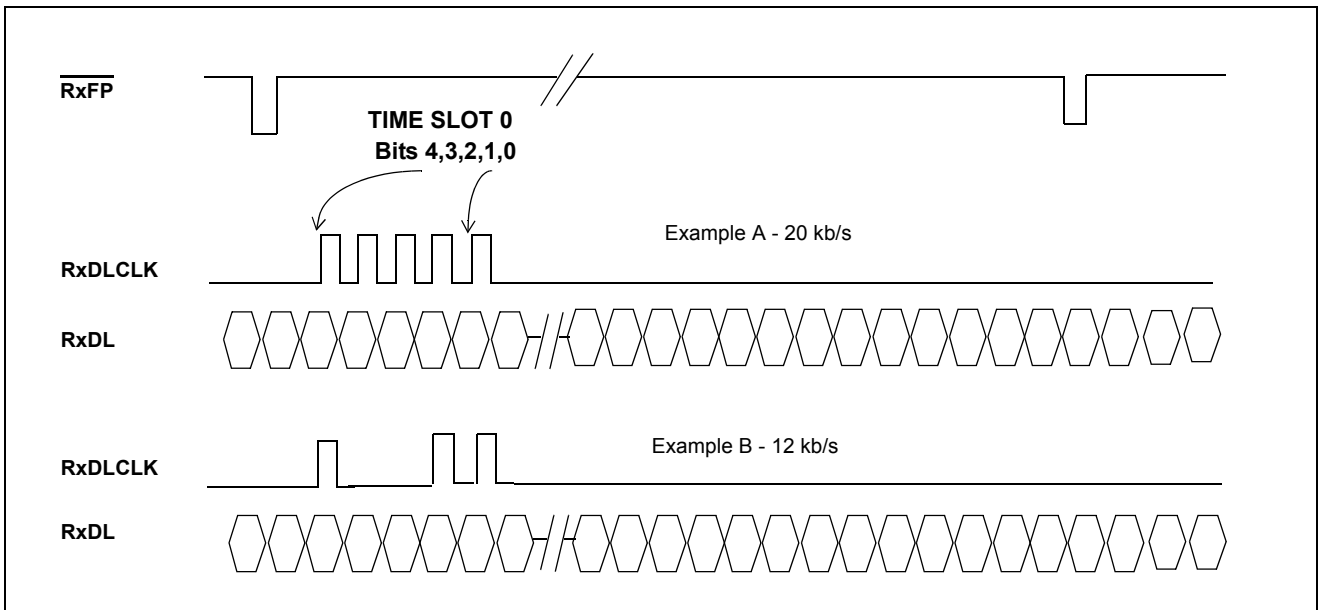

Figure 23 - Receive Data Link Functional Timing (E1 mode)

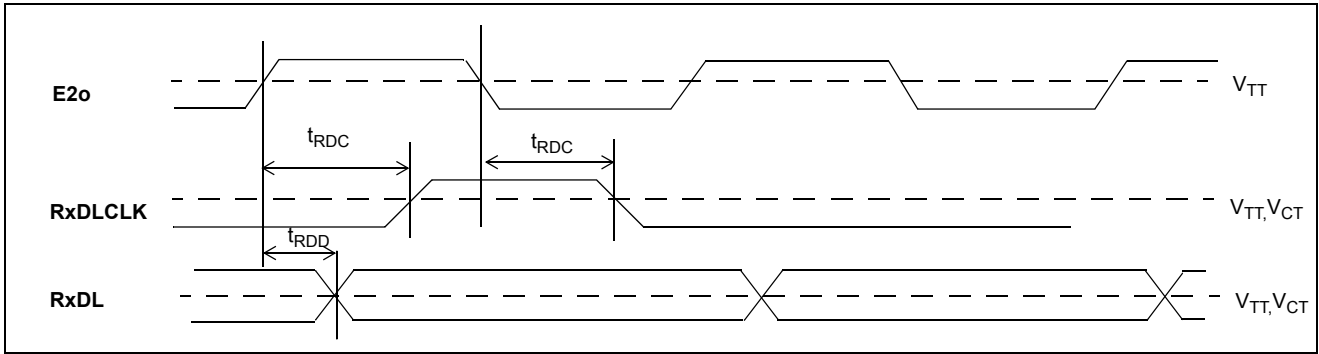

Figure 24 - Receive Data Link Timing Diagram (E1 mode)

AC Electrical Characteristics - ST-BUS Timing (E1 or T1 mode)

	Characteristic	Sym.	Min.	Typ.	Max.	Units	Test Conditions
1	C4b Clock Width High or Low	t_{4W}	80	122	150	ns	2.048 Mb/s mode
2	C4b Clock Width High or Low	t_{FPS}	25	30.5	35	ns	8.192 Mb/s mode
3	Frame Pulse Hold	t_{FPH}	10			ns	
4	Frame Pulse Setup	t_{FPS}	10			ns	2.048 Mb/s mode
5	Frame Pulse Low	t_{FPL}	75			ns	
6	Serial Input Setup	t_{SIS}	10			ns	
7	Serial Input Hold	t_{SIH}	10			ns	
8	Serial Output Delay	t_{SOD}	75			ns	150 pF
9	Frame Pulse Delay	t_{FDD}	75			ns	

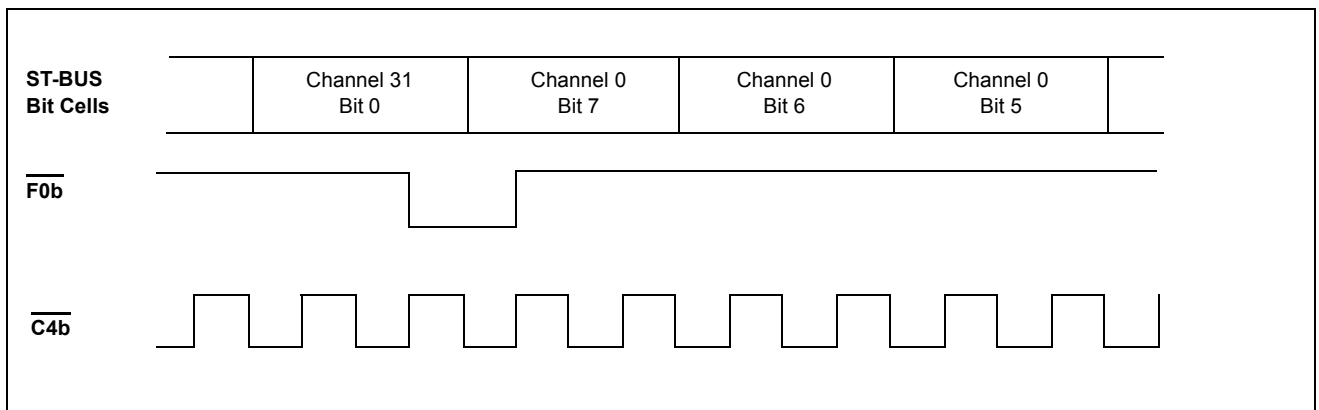

Figure 25 - ST-BUS Functional Timing Diagram - 2.048 Mb/s Mode

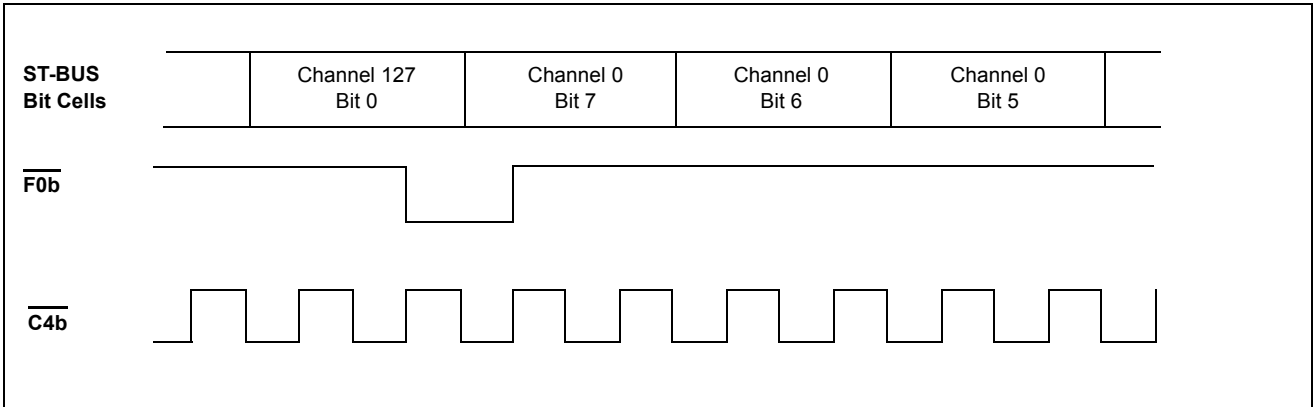

Figure 26 - ST-BUS Functional Timing Diagram - 8.192 Mb/s Mode

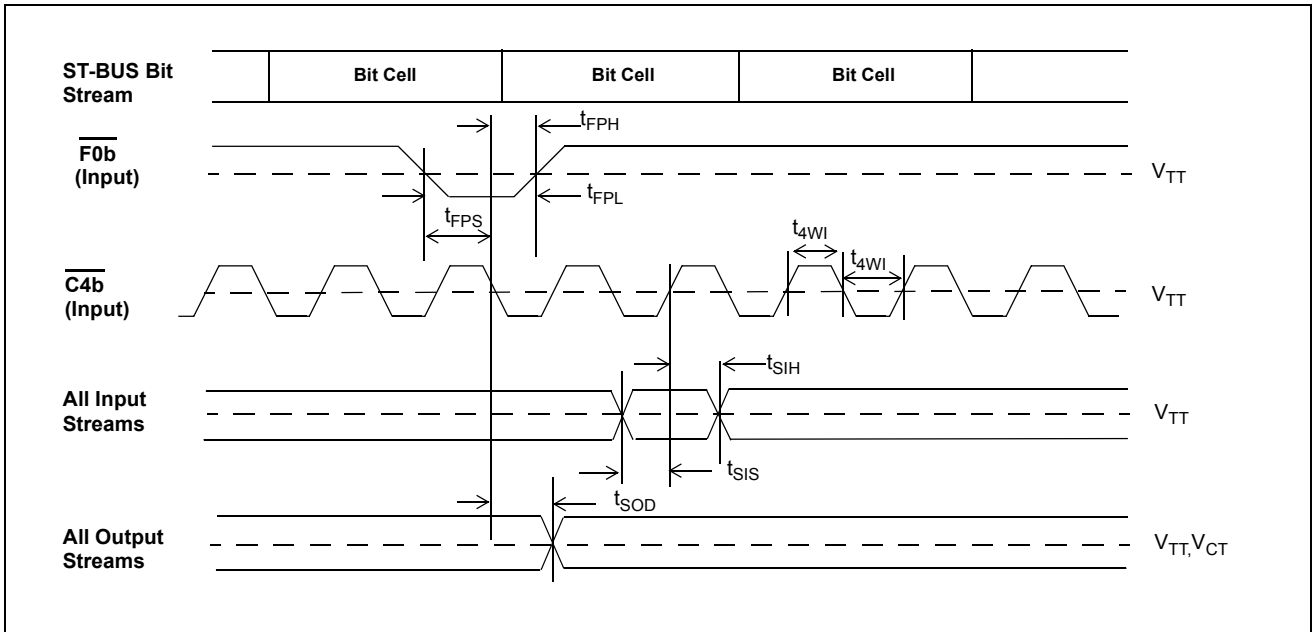

Figure 27 - ST-BUS Timing Diagram (Input Clocks)

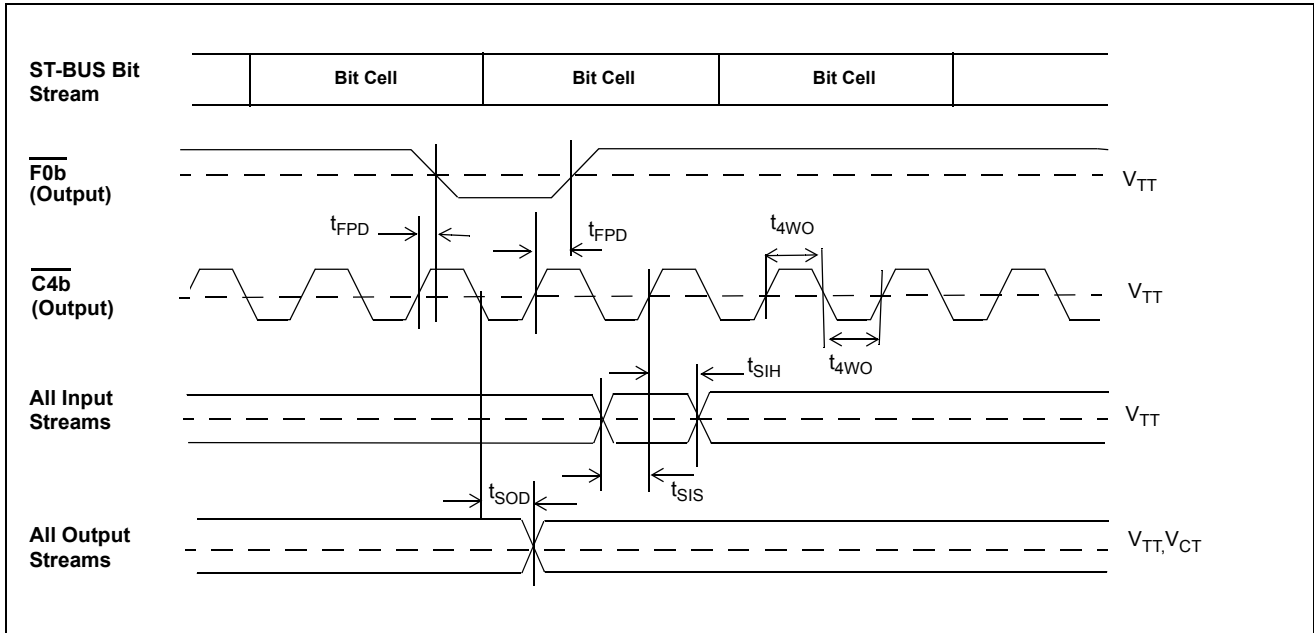

Figure 28 - ST-BUS Timing Diagram (Output Clocks)

AC Electrical Characteristics - Multiframe Timing (T1 or E1 mode)

	Characteristic	Sym.	Min.	Typ.	Max.	Units	Test Conditions
1	Receive Multiframe Output Delay	t_{MOD}	50			ns	150 pF
2	Transmit Multiframe Setup	t_{MS}	50			ns	
3	Transmit Multiframe Hold	t_{MH}	50		*	ns	* 256 C2 periods -100 nsec

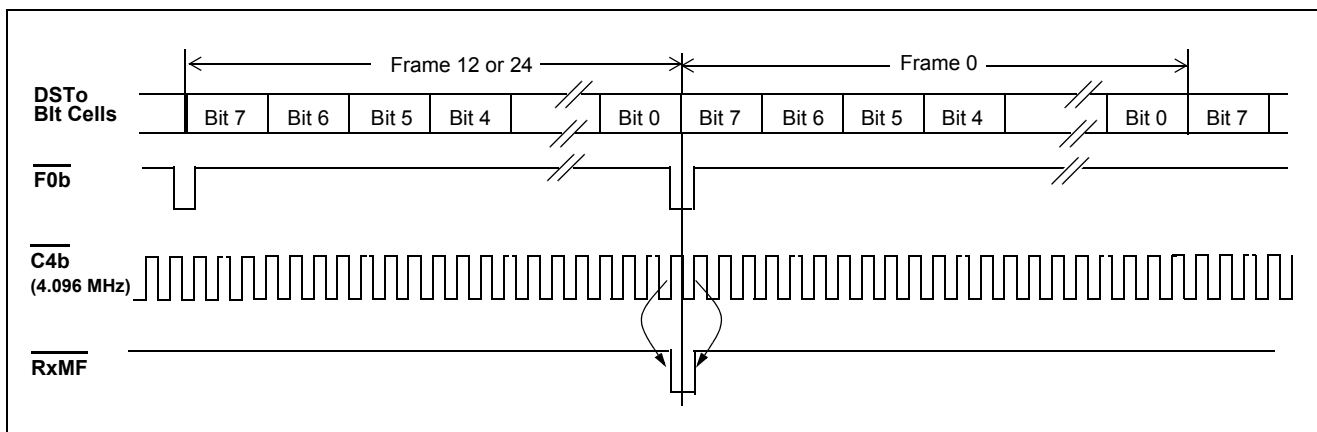

Figure 29 - Receive Multiframe Functional Timing (T1 mode)

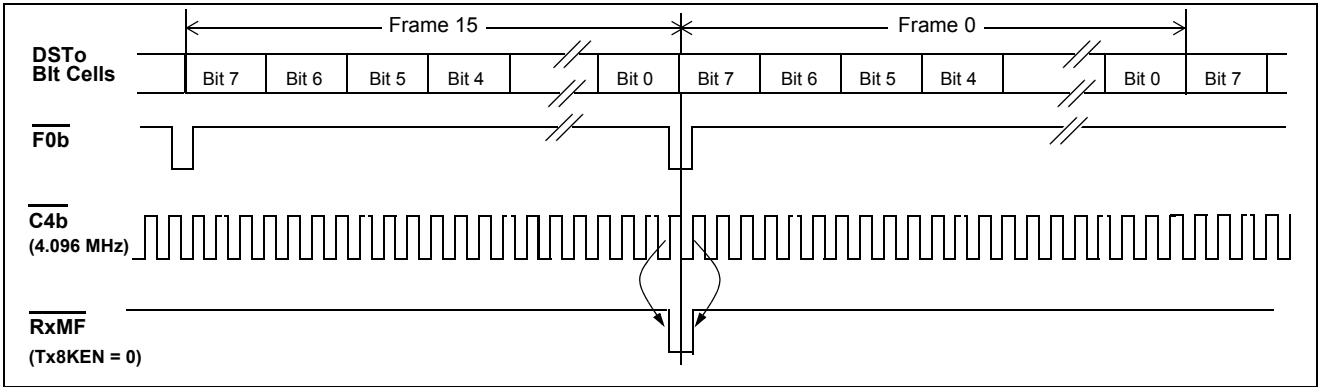

Figure 30 - Receive Multiframe Functional Timing (E1 mode)

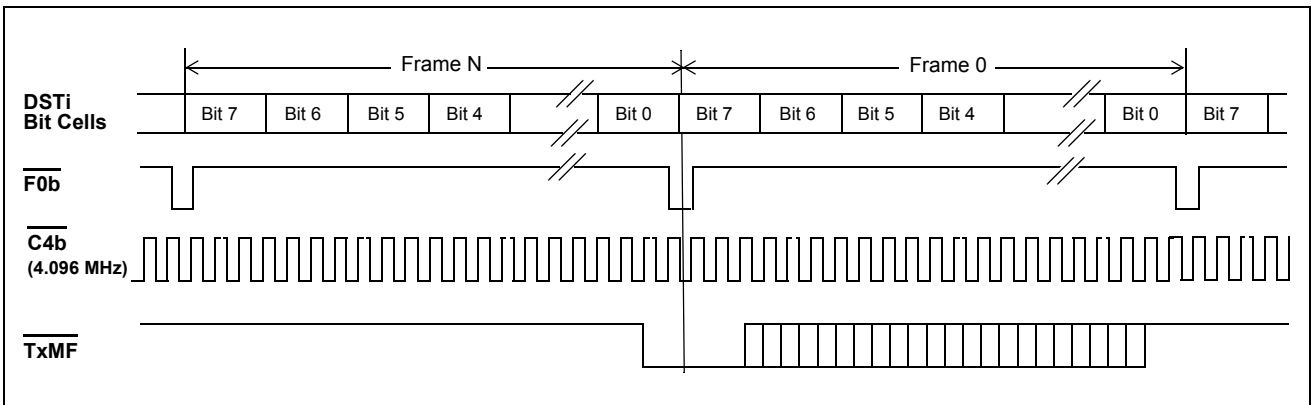

Figure 31 - Transmit Multiframe Functional Timing (T1 mode or E1 mode)

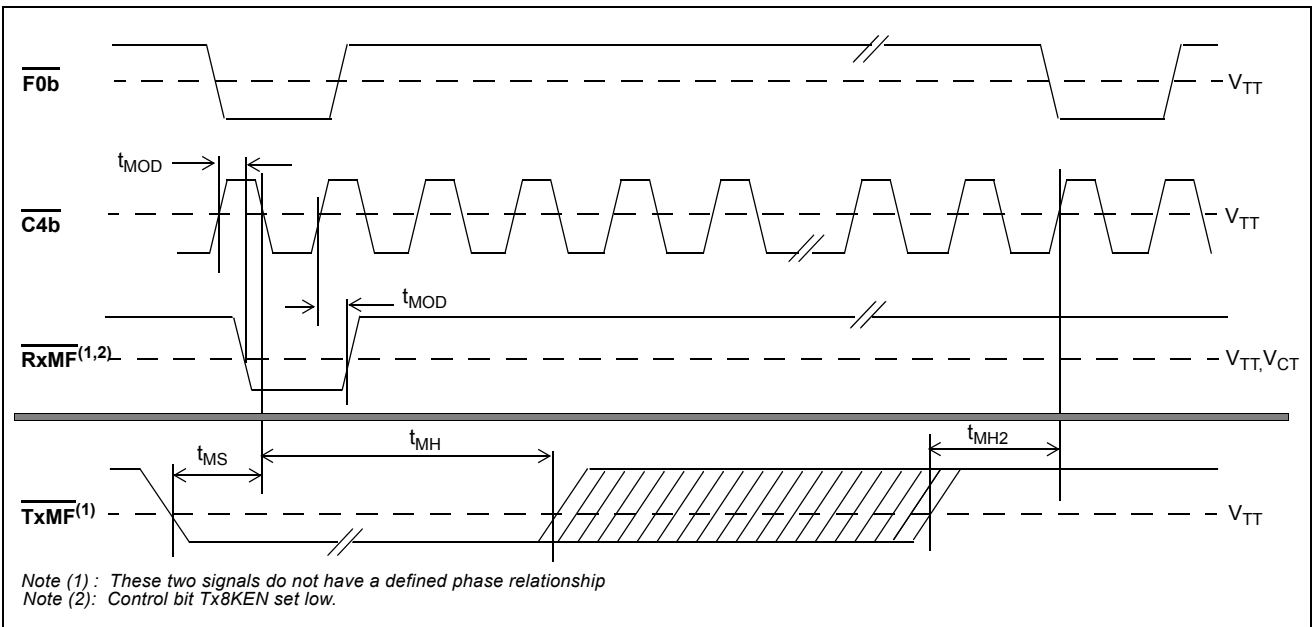

Figure 32 - Multiframe Timing Diagram (T1 mode or E1 mode)

AC Electrical Characteristics - TXA/TXB (E1 or T1 mode)

	Characteristic	Sym.	Min.	Typ.	Max.	Units	Test Conditions
1	Serial Output Delay	t_{SOD}		20		ns	150 pF
2	TxFP Output Delay	t_{TFOD}		20		ns	150 pF

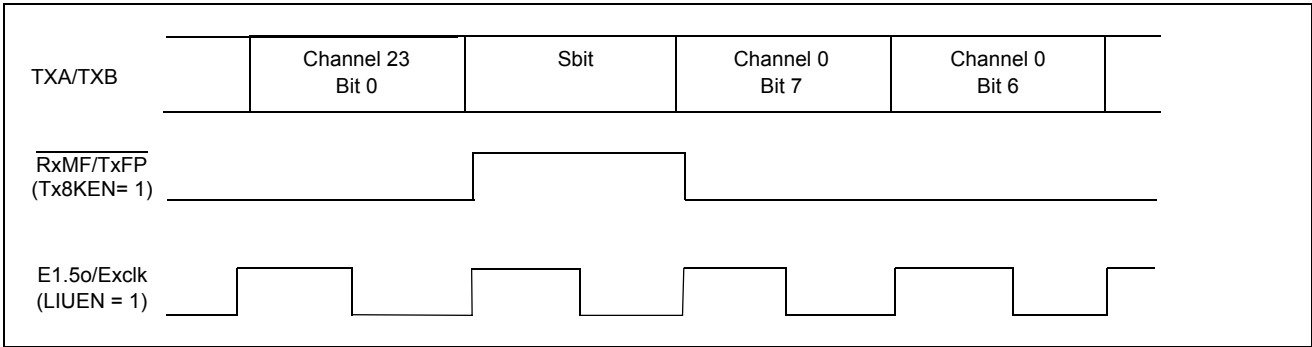

Figure 33 - TXA/TXB Functional Timing (T1 mode)

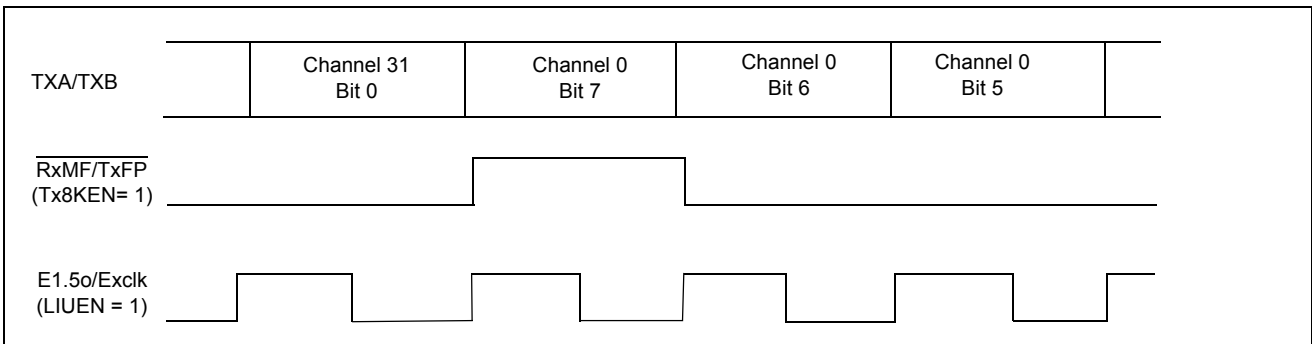

Figure 34 - TXA/TXB Functional Timing (E1 mode)

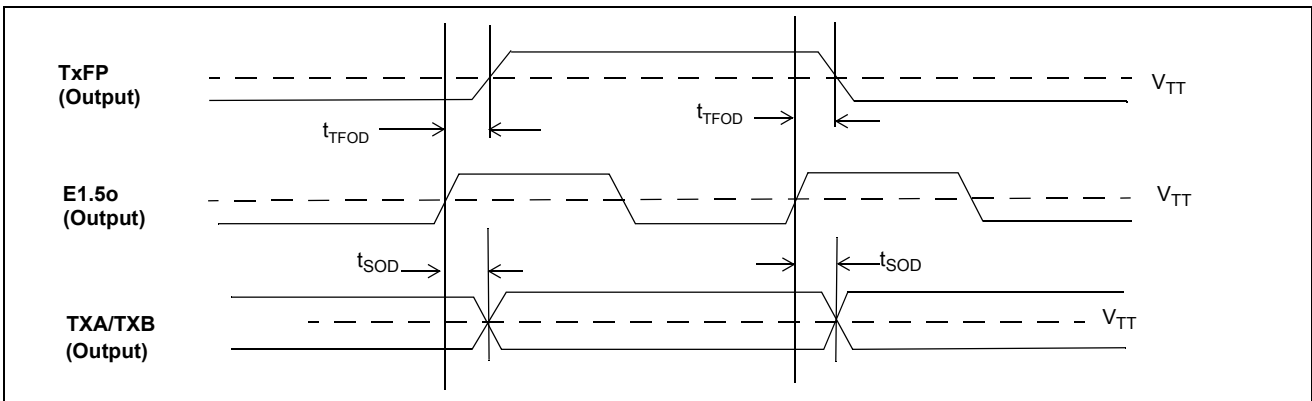

Figure 35 - TXA/TXB Timing Diagram (T1 mode or E1 mode)

AC Electrical Characteristics - IMA Timing (E1 or T1 mode)

	Characteristic	Sym.	Min.	Typ.	Max.	Units	Test Conditions
1	C4b Clock Width High or Low	t_{4W}	80	122	150	ns	E1 mode
2	Frame Pulse Setup	t_{FPS}	10			ns	
3	Frame Pulse Hold	t_{FPS}	10			ns	
4	Serial Input Setup	t_{SIS}	4			ns	
5	Serial Input Hold	t_{SIH}	4			ns	
6	Serial Output Delay	t_{SOD}	45			ns	150 pF

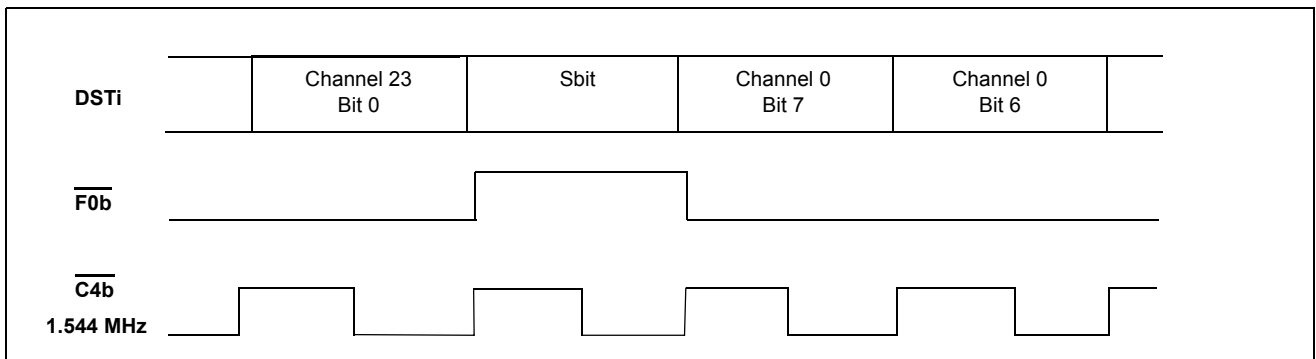

Figure 36 - Tx IMA Functional Timing (T1 mode)

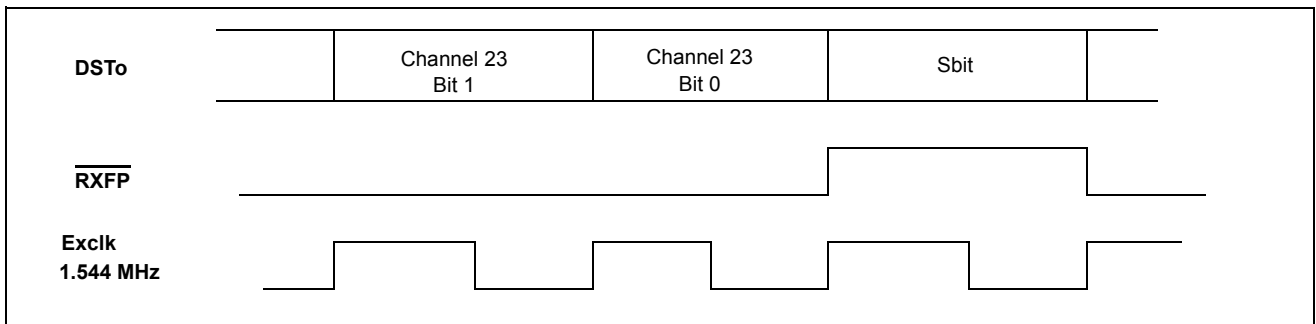

Figure 37 - Rx IMA Functional Timing (T1 mode)

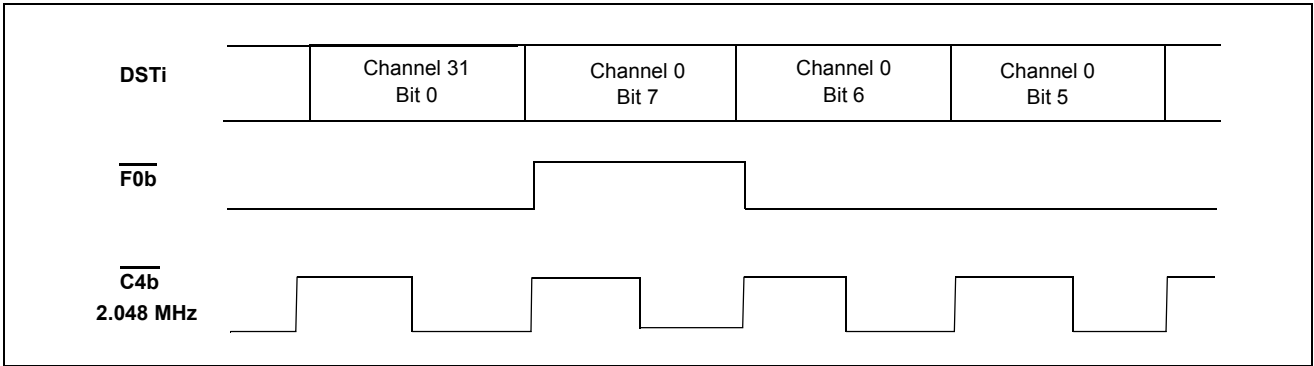

Figure 38 - Tx IMA Functional Timing (E1 mode)

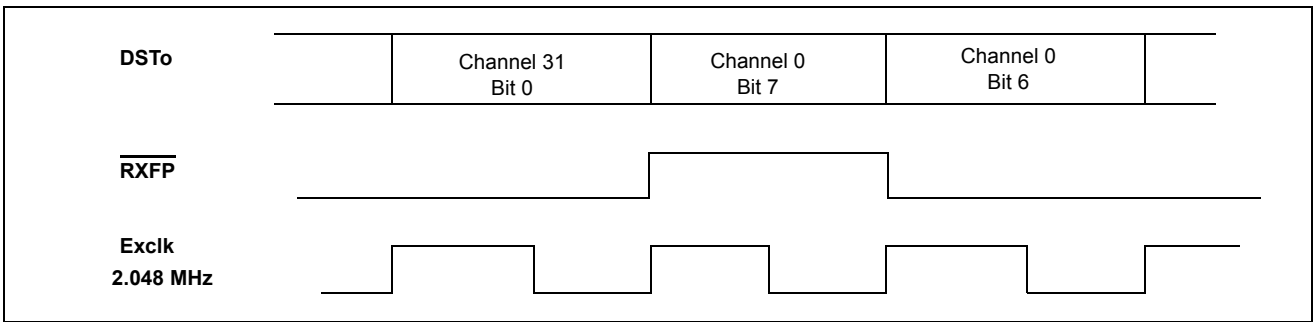

Figure 39 - Rx IMA Functional Timing (E1 mode)

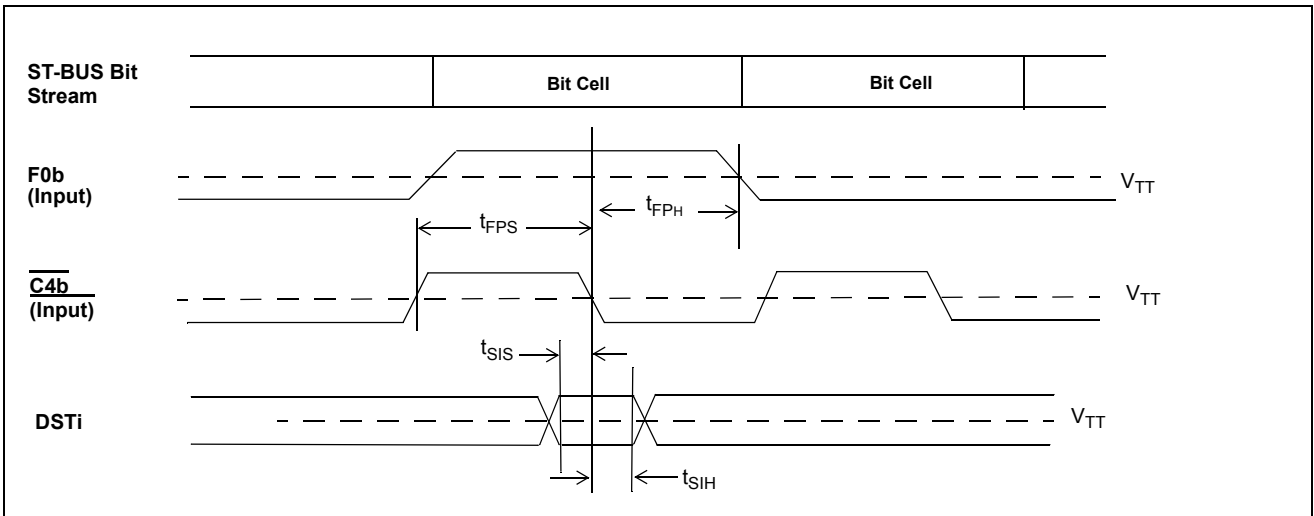

Figure 40 - Tx IMA Timing Diagram (T1 mode or E1 mode)

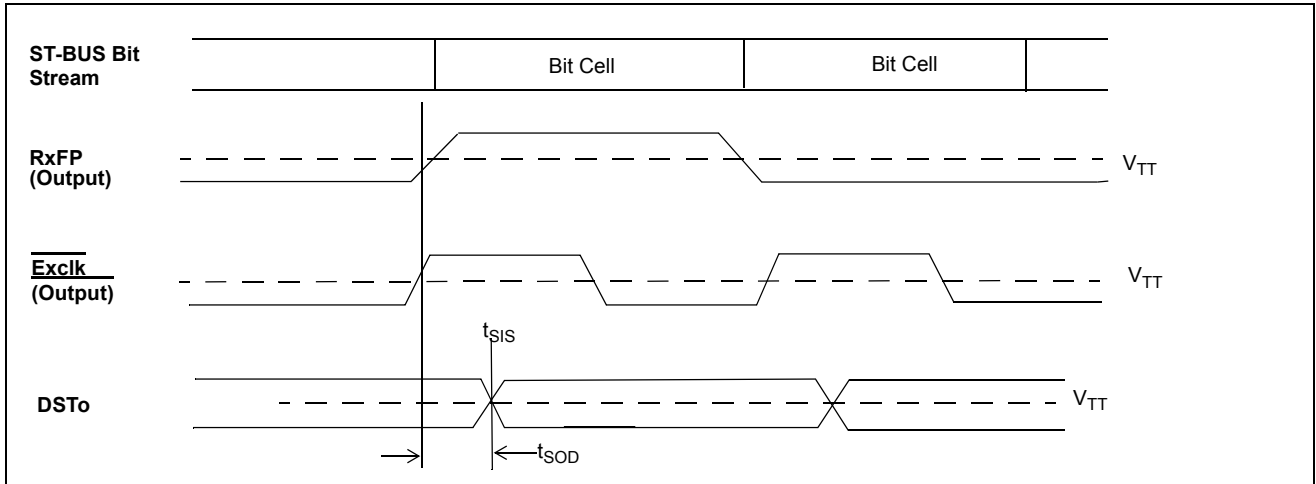

Figure 41 - Rx IMA Timing Diagram (T1 mode or E1 mode)

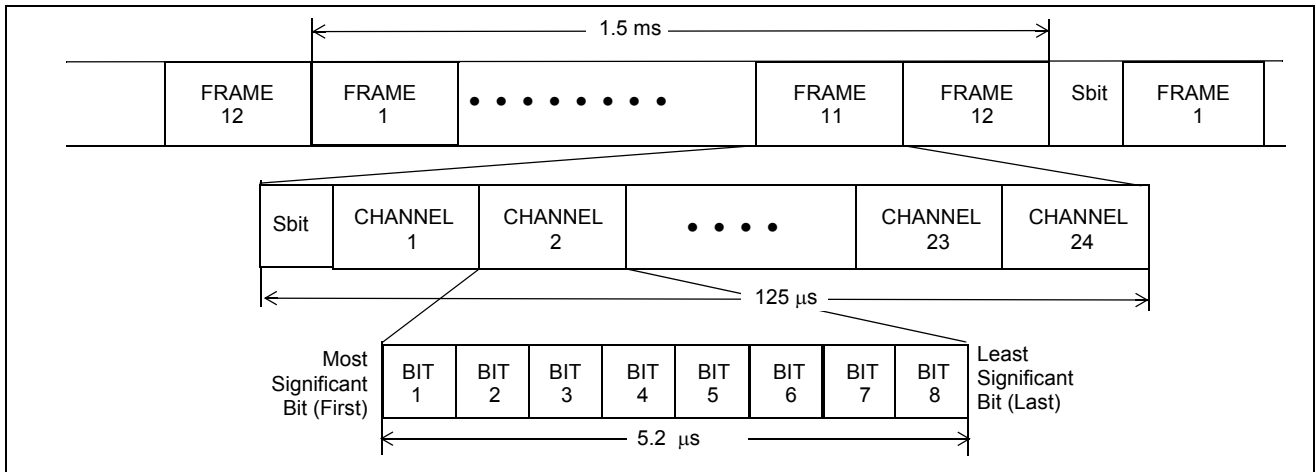

Figure 42 - D4 Format

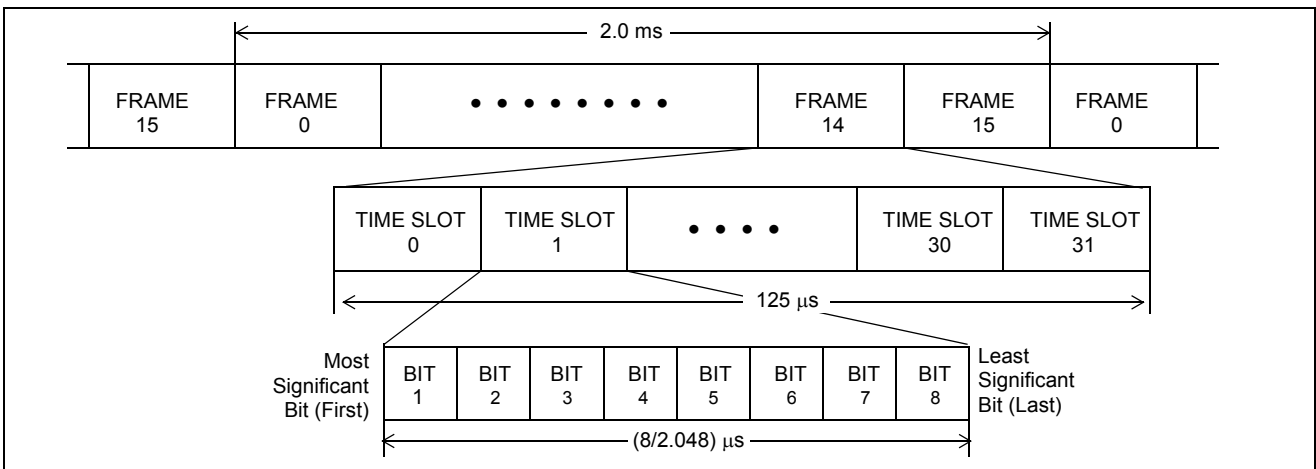

Figure 43 - PCM 30 Format

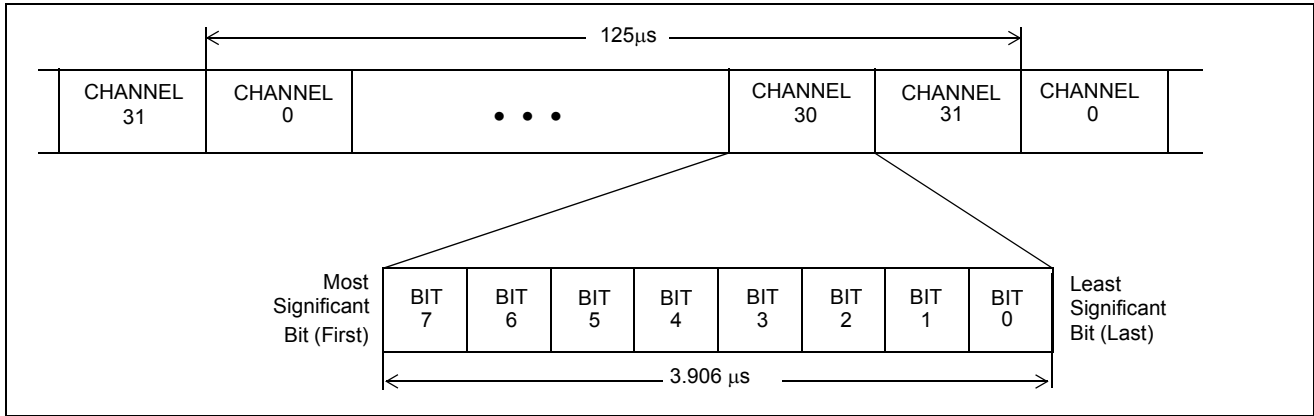

Figure 44 - ST-BUS Stream Format - 2.048 Mb/s

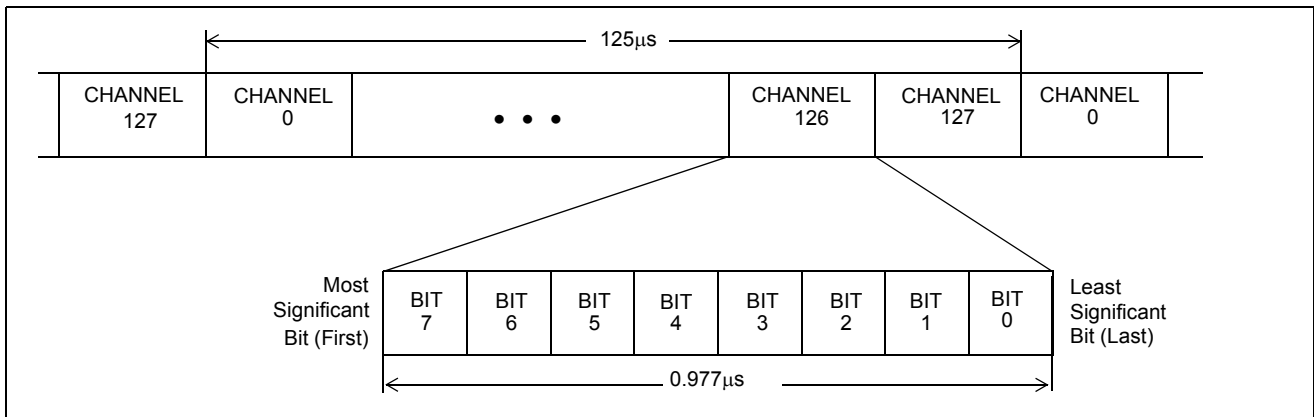
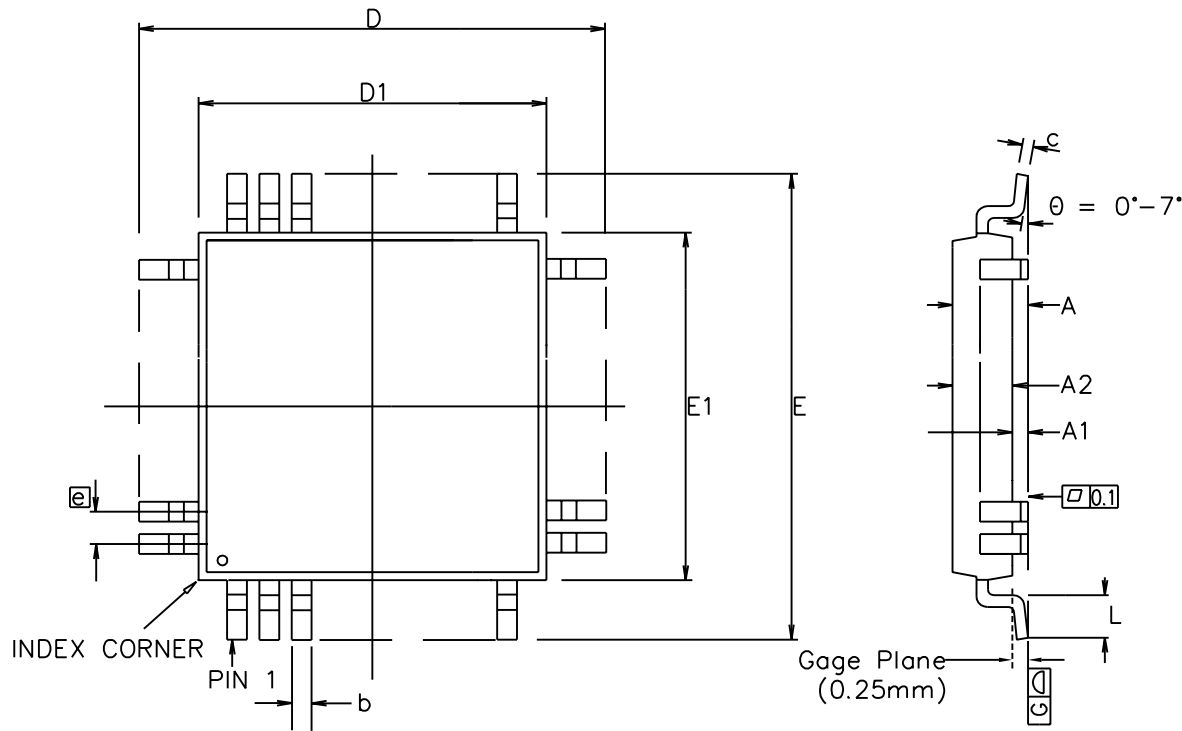

Figure 45 - ST-BUS Stream Format 8.192 Mb/s



Symbol	Control Dimensions in millimetres		Altern. Dimensions in inches	
	MIN	MAX	MIN	MAX
A	---	1.60	0.002	0.063
A1	0.05	0.15	0.010	0.006
A2	1.35	1.45	0.053	0.057
D	16.00	BSC	0.630	BSC
D1	14.00	BSC	0.551	BSC
E	16.00	BSC	0.630	BSC
E1	14.00	BSC	0.551	BSC
L	0.45	0.75	0.018	0.030
e	0.65	BSC	0.026	BSC
b	0.22	0.38	0.009	0.015
c	0.09	0.20	0.004	0.008
Pin features				
N	80			
ND	20			
NE	20			
NOTE	SQUARE			

Conforms to JEDEC MS-026 BEC Iss. C

Notes:

1. Pin 1 indicator may be a corner chamfer, dot or both.
2. Controlling dimensions are in millimeters.
3. The top package body size may be smaller than the bottom package body size by a max. of 0.15 mm.
4. Dimension D1 and E1 do not include mould protrusion.
5. Dimension b does not include dambar protrusion.
6. Coplanarity, measured at seating plane G, to be 0.10 mm max.

This drawing supersedes 418/ED/51210/024 (Swindon)

© Zarlink Semiconductor 2002 All rights reserved.				
ISSUE	1	2	3	
ACN	201363	207143	212836	
DATE	28Oct96	14Jul99	21May02	
APPRD.				



		Package Code	QC
Previous package codes		Package Outline for 80 lead LQFP (14 x 14 x 1.4mm) 2.0mm Footprint	
GP / B			
		GPD00247	

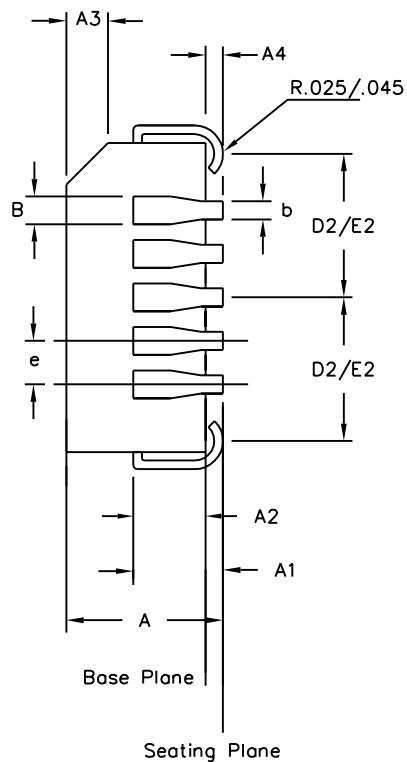
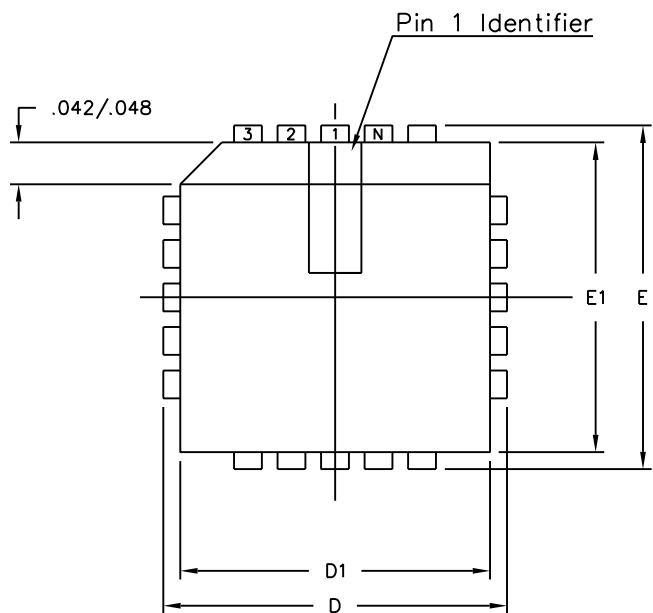

Symbol	Control Dimensions in inches		Altern. Dimensions in millimetres	
	MIN	MAX	MIN	MAX
A	0.165	0.180	4.19	4.57
A1	0.090	0.120	2.29	3.05
A2	0.062	0.083	1.57	2.11
A3	0.042	0.056	1.07	1.42
A4	0.020	—	0.51	—
D	0.985	0.995	25.02	25.27
D1	0.950	0.958	24.13	24.33
D2	0.441	0.469	11.20	11.91
E	0.985	0.995	25.02	25.27
E1	0.950	0.958	24.13	24.33
E2	0.441	0.469	11.20	11.91
B	0.026	0.032	0.66	0.81
b	0.013	0.021	0.33	0.53
e	0.050	BSC	1.27	BSC
Pin features				
ND	17			
NE	17			
N	68			
Note	Square			
Conforms to JEDEC MS-018AE Iss. A				

Notes:

- All dimensions and tolerances conform to ANSI Y14.5M-1982
- Dimensions D1 and E1 do not include mould protrusions. Allowable mould protrusion is 0.010" per side. Dimensions D1 and E1 include mould protrusion mismatch and are determined at the parting line, that is D1 and E1 are measured at the extreme material condition at the upper or lower parting line.
- Controlling dimensions in Inches.
- "N" is the number of terminals.
- Not To Scale
- Dimension R required for 120° minimum bend.

© Zarlink Semiconductor 2002 All rights reserved.

ISSUE	1	2	3	
ACN	5958	207493	213095	
DATE	15Aug94	16Sep99	15Jul02	
APPRD.				



Previous package codes

HP / P

Package Code QA

Package Outline for
68 lead PLCC

GPD00005



**For more information about all Zarlink products
visit our Web Site at
www.zarlink.com**

Information relating to products and services furnished herein by Zarlink Semiconductor Inc. or its subsidiaries (collectively "Zarlink") is believed to be reliable. However, Zarlink assumes no liability for errors that may appear in this publication, or for liability otherwise arising from the application or use of any such information, product or service or for any infringement of patents or other intellectual property rights owned by third parties which may result from such application or use. Neither the supply of such information or purchase of product or service conveys any license, either express or implied, under patents or other intellectual property rights owned by Zarlink or licensed from third parties by Zarlink, whatsoever. Purchasers of products are also hereby notified that the use of product in certain ways or in combination with Zarlink, or non-Zarlink furnished goods or services may infringe patents or other intellectual property rights owned by Zarlink.

This publication is issued to provide information only and (unless agreed by Zarlink in writing) may not be used, applied or reproduced for any purpose nor form part of any order or contract nor to be regarded as a representation relating to the products or services concerned. The products, their specifications, services and other information appearing in this publication are subject to change by Zarlink without notice. No warranty or guarantee express or implied is made regarding the capability, performance or suitability of any product or service. Information concerning possible methods of use is provided as a guide only and does not constitute any guarantee that such methods of use will be satisfactory in a specific piece of equipment. It is the user's responsibility to fully determine the performance and suitability of any equipment using such information and to ensure that any publication or data used is up to date and has not been superseded. Manufacturing does not necessarily include testing of all functions or parameters. These products are not suitable for use in any medical products whose failure to perform may result in significant injury or death to the user. All products and materials are sold and services provided subject to Zarlink's conditions of sale which are available on request.

Purchase of Zarlink's I²C components conveys a licence under the Philips I²C Patent rights to use these components in and I²C System, provided that the system conforms to the I²C Standard Specification as defined by Philips.

Zarlink, ZL and the Zarlink Semiconductor logo are trademarks of Zarlink Semiconductor Inc.

Copyright Zarlink Semiconductor Inc. All Rights Reserved.

TECHNICAL DOCUMENTATION - NOT FOR RESALE

Компания «Life Electronics» занимается поставками электронных компонентов импортного и отечественного производства от производителей и со складов крупных дистрибьюторов Европы, Америки и Азии.

С конца 2013 года компания активно расширяет линейку поставок компонентов по направлению коаксиальный кабель, кварцевые генераторы и конденсаторы (керамические, пленочные, электролитические), за счёт заключения дистрибьюторских договоров

Мы предлагаем:

- Конкурентоспособные цены и скидки постоянным клиентам.
- Специальные условия для постоянных клиентов.
- Подбор аналогов.
- Поставку компонентов в любых объемах, удовлетворяющих вашим потребностям.
- Приемлемые сроки поставки, возможна ускоренная поставка.
- Доставку товара в любую точку России и стран СНГ.
- Комплексную поставку.
- Работу по проектам и поставку образцов.
- Формирование склада под заказчика.
- Сертификаты соответствия на поставляемую продукцию (по желанию клиента).
- Тестирование поставляемой продукции.
- Поставку компонентов, требующих военную и космическую приемку.
- Входной контроль качества.
- Наличие сертификата ISO.

В составе нашей компании организован Конструкторский отдел, призванный помогать разработчикам, и инженерам.

Конструкторский отдел помогает осуществить:

- Регистрацию проекта у производителя компонентов.
- Техническую поддержку проекта.
- Защиту от снятия компонента с производства.
- Оценку стоимости проекта по компонентам.
- Изготовление тестовой платы монтаж и пусконаладочные работы.



Тел: +7 (812) 336 43 04 (многоканальный)

Email: org@lifeelectronics.ru