

**Signal Conditioned Accelerometer**  
**0.5 to 4.5 VDC Output**  
**Integral Temperature Compensation**  
**High Performance**

- ▶ Vibration/Shock Testing
- ▶ Geophysical Monitoring
- ▶ Modal Analysis
- ▶ Structural Analysis
- ▶ Elevator Ride Control



## DESCRIPTION

The Model 3140 is a high performance accelerometer intended for instrumentation applications. The 3140 provides a fully signal conditioned output with performance similar to traditional instrumentation accelerometers but at a much lower cost.

The accelerometer consists of a silicon micro machined accelerometer with signal conditioning electronics in a light-weight Valox™ housing that can be easily attached to a mounting surface.

The sensing element is a micro machined silicon mass suspended by multiple beams from a silicon frame. Piezoresistors located in the beams change their resistance as the motion of the suspended mass changes the strain in the beams. Silicon caps on the top and bottom of the device are added to provide over-range stops. This design provides for a very low profile, high shock resistance, durability and built-in damping over a wide usable bandwidth.

A lower cost version of the 3140 is available for applications that do not require the temperature performance offered with the 3140. Please refer to the Model 3145 for additional information.

## FEATURES

- ▶ Bolt Mount
- ▶ ±0.5% Non-linearity (typical)
- ▶ ±2.0% Temperature Performance
- ▶ DC Response
- ▶ Built-in Damping
- ▶ Built-in Overrange Stops
- ▶ Low Power

## STANDARD RANGES

Range	g
±2	●
±5	●
±10	●
±20	●
±50	●
±100	●

## DIMENSIONS

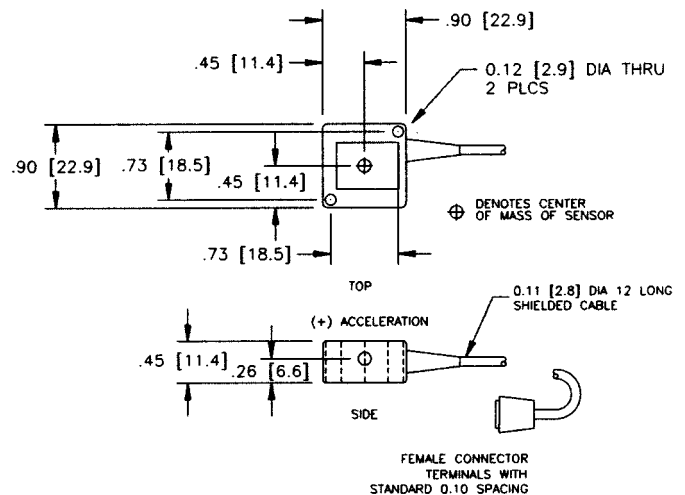

ALL DIMENSIONS ARE IN INCHES

## PERFORMANCE SPECIFICATIONS

Supply Current: 12 VDC

Ambient Temperature: 25°C (Unless otherwise specified)

PARAMETERS	RANGE					
	±2G	±5G	±10G	±20G	±50G	±100G
Frequency Response [MIN] See notes 2, 8	0-200	0-300	0-400	0-500	0-600	0-1500
Mounted Resonant Frequency [MIN] See note 2	450	600	950	1500	2750	3000
Sensitivity (Nominal)	1 V/g	400mV/g	200mV/g	100mV/g	40mV/g	20mV/g

PARAMETERS	MIN	TYP	MAX	UNITS	NOTES
Full Scale Output Span	3.92	4.00	4.08	Volts	1, 2
Zero Acceleration Output	2.46	2.50	2.54	Volts	1, 2
Accuracy		0.5	1.0	±% Span	3
Transverse Sensitivity		1.0	3.0	±% Span	
Temperature Error - Span (-20°C to +85°C)		1.0	2.0	±% Span	2, 4
Temperature Error - Zero (-20°C to +85°C)		1.0	2.0	±% Span	2, 4
Supply Voltage	8.0	12.0	30.0	Volts	
Supply Current		5.0		mA	
Reference Voltage		2.5		Volts	5
Output Resistance		0.1		Ω	
Output Noise		0.5		mV p-p	6
Output Load Resistance	5			kΩ	
Acceleration Limits		20X		Rated	
Operating Temperature	-20°C to +85°C				
Storage Temperature	-40°C to +125°C				
Weight (Including Cable)	13 Grams				

## Notes

- The output voltage increases from the Zero Acceleration Output for positive acceleration and decreases for negative acceleration. The sensitivity is then 2V/Range. For example, the ±5g range has a sensitivity of 2V/5g or 400mV/g.
- Actual test data for this parameter is included on the calibration sheet provided with each sensor.
- Includes repeatability, hysteresis, and linearity (best fit straight line).
- Compensated temperature range: -20°C to +85°C in reference to 25°C.
- Pin 2 provides an optional 2.5V reference which may be used, if desired, to provide a stable zero-g reference. Thus, the full scale differential output between Pin 2 and Pin 4 would be ± 2 VDC. If a single ended output signal is preferred (0.5-4.5 VDC), make no connection to Pin 2. To avoid damage to the internal voltage regulator, do not connect Pin 2 to Pin 1 (gnd). Minimum load resistance connected to Pin 2 without affecting output is 100 kΩ.
- 10 Hz to 1 kHz.
- To use an alternate electrical connector, refer to the following color code for proper electrical connections: Pin 1 - Green; Pin 2 - Yellow; Pin 3 - Red; Pin 4 - Blue; Pin 5 - Shield. Note: Removing the connector voids the product warranty.
- The useful frequency range is defined as the range of frequencies over which the device sensitivity is within ±5% of the DC value.

## ORDERING INFORMATION



## CONNECTIONS

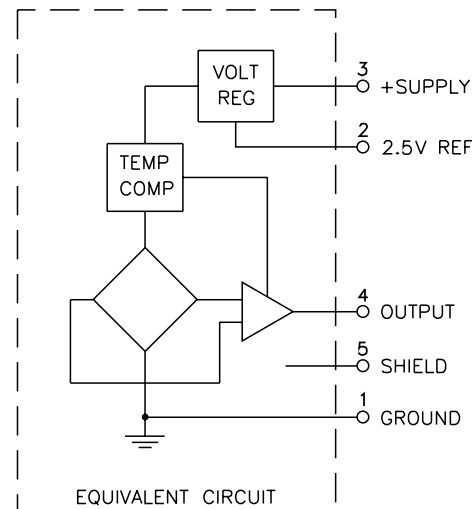

June 2001

Компания «Life Electronics» занимается поставками электронных компонентов импортного и отечественного производства от производителей и со складов крупных дистрибьюторов Европы, Америки и Азии.

С конца 2013 года компания активно расширяет линейку поставок компонентов по направлению коаксиальный кабель, кварцевые генераторы и конденсаторы (керамические, пленочные, электролитические), за счёт заключения дистрибьюторских договоров

Мы предлагаем:

- Конкурентоспособные цены и скидки постоянным клиентам.
- Специальные условия для постоянных клиентов.
- Подбор аналогов.
- Поставку компонентов в любых объемах, удовлетворяющих вашим потребностям.
- Приемлемые сроки поставки, возможна ускоренная поставка.
- Доставку товара в любую точку России и стран СНГ.
- Комплексную поставку.
- Работу по проектам и поставку образцов.
- Формирование склада под заказчика.
- Сертификаты соответствия на поставляемую продукцию (по желанию клиента).
- Тестирование поставляемой продукции.
- Поставку компонентов, требующих военную и космическую приемку.
- Входной контроль качества.
- Наличие сертификата ISO.

В составе нашей компании организован Конструкторский отдел, призванный помогать разработчикам, и инженерам.

Конструкторский отдел помогает осуществить:

- Регистрацию проекта у производителя компонентов.
- Техническую поддержку проекта.
- Защиту от снятия компонента с производства.
- Оценку стоимости проекта по компонентам.
- Изготовление тестовой платы монтаж и пусконаладочные работы.



Тел: +7 (812) 336 43 04 (многоканальный)

Email: [org@lifeelectronics.ru](mailto:org@lifeelectronics.ru)