

SYSMAC
Programmable Controllers
C200HS

INSTALLATION GUIDE

OMRON

C200HS Programmable Controllers

Installation Guide

Revised March 2003

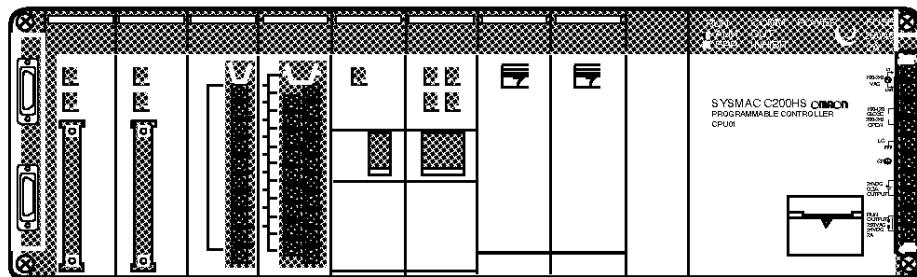



Notice:

OMRON products are manufactured for use according to proper procedures by a qualified operator and only for the purposes described in this manual.

The following conventions are used to indicate and classify precautions in this manual. Always heed the information provided with them. Failure to heed precautions can result in injury to people or damage to property.

 **DANGER** Indicates an imminently hazardous situation which, if not avoided, will result in death or serious injury.

 **WARNING** Indicates a potentially hazardous situation which, if not avoided, could result in death or serious injury.

 **Caution** Indicates a potentially hazardous situation which, if not avoided, may result in minor or moderate injury, or property damage.

OMRON Product References

All OMRON products are capitalized in this manual. The word “Unit” is also capitalized when it refers to an OMRON product, regardless of whether or not it appears in the proper name of the product.

The abbreviation “Ch,” which appears in some displays and on some OMRON products, often means “word” and is abbreviated “Wd” in documentation in this sense.

The abbreviation “PC” means Programmable Controller and is not used as an abbreviation for anything else.

Visual Aids

The following headings appear in the left column of the manual to help you locate different types of information.

Note Indicates information of particular interest for efficient and convenient operation of the product.

1, 2, 3... 1. Indicates lists of one sort or another, such as procedures, checklists, etc.

© OMRON, 1993

All rights reserved. No part of this publication may be reproduced, stored in a retrieval system, or transmitted, in any form, or by any means, mechanical, electronic, photocopying, recording, or otherwise, without the prior written permission of OMRON.

No patent liability is assumed with respect to the use of the information contained herein. Moreover, because OMRON is constantly striving to improve its high-quality products, the information contained in this manual is subject to change without notice. Every precaution has been taken in the preparation of this manual. Nevertheless, OMRON assumes no responsibility for errors or omissions. Neither is any liability assumed for damages resulting from the use of the information contained in this publication.

TABLE OF CONTENTS

PRECAUTIONS	xi
1 Intended Audience	xii
2 General Precautions	xii
3 Safety Precautions	xii
4 Operating Environment Precautions	xii
5 Application Precautions	xiii
6 Conformance to EC Directives	xiv
SECTION 1	
Introduction	1
1-1 What is a Control System?	2
1-2 The Role of the PC	4
1-3 How Does a PC Work?	5
1-4 New C200HS Features	8
1-5 Comparisons Between C200HS and C200H	11
1-6 Compatibility of C200HS and C200H Devices	13
SECTION 2	
System Configuration and Unit Description	15
2-1 System Configuration	16
2-2 CPUs	18
2-3 Expansion I/O Racks	24
2-4 Power Supply Unit	25
2-5 I/O Units	26
SECTION 3	
Installation	33
3-1 Installation Environment	34
3-2 Mounting Units to the Backplane	35
3-3 Installing Racks	39
3-4 I/O Connecting Cable	40
3-5 Mounting Requirements	41
3-6 Installing Memory Cassettes	43
SECTION 4	
Wiring	45
4-1 Power Supply Wiring	46
4-2 AC Power Supply	46
4-3 DC Power Supply	47
4-4 RUN Output Terminals	48
4-5 Grounding	48
4-6 Backplane Insulation Plate	49
4-7 Standard I/O Unit Wiring	50
4-8 Input Circuits	53
4-9 Output Circuits	54
4-10 External Wiring	57
4-11 System Design and Safety Considerations	57
SECTION 5	
Peripheral Devices and System Expansion	61
5-1 Programming Console	62
5-2 Checking Initial C200HS Operation	64
5-3 Expanding the System	64
5-4 Special I/O Units	67
5-5 Ladder Support Software (LSS)	73
5-6 SYSMAC Support Software (SSS)	73

TABLE OF CONTENTS

SECTION 6	
Troubleshooting	75
6-1 Alarm Indicators	76
6-2 Programmed Alarms and Error Messages	76
6-3 Reading and Clearing Errors and Messages	76
6-4 Error Messages	77
6-5 CPU Racks and Expansion I/O Racks	81
6-6 Input Units	82
6-7 Output Units	83
SECTION 7	
Inspection and Maintenance	85
7-1 CPU and Power Supply Fuses	86
7-2 Output Unit Fuses	86
7-3 Output Unit Relays	87
7-4 Batteries	90
Appendices	
A Standard Models	93
B Specifications	103
Glossary	205
Index	209
Revision History	213

About this Manual:

This manual describes the installation of C200HS Programmable Controllers, and it includes the sections described below. Programming and operating information is provided in the *C200HS Operation Manual*.

Please read this manual completely and be sure you understand the information provided before attempting to install a C200HS PC. **Be sure to read the precautions in the following section.**

Section 1 is an introduction to Programmable Controllers (or PCs). General information is provided on PCs and how they work. This section also provides an overview of the new features of the C200HS and the major differences between the C200HS and the C200H.

Section 2 provides a description of all the components of the C200HS. The names of all the individual parts of each Unit are given.

Section 3 describes how to install a PC System, including mounting the various Units and configuring the System.

Section 4 provides the information necessary to wire a C200HS System.

Section 5 provides general information about the Programming Console, LSS, SSS, and ways in which the C200HS System can be expanded for more versatility.

Section 6 provides information on hardware and software errors that occur during PC operation. It also provides troubleshooting charts for CPU Racks, Expansion I/O Racks, Input Units, and Output Units.

Section 7 covers maintenance and inspection, and explains how to replace consumable components such as fuses, relays, and batteries.

Appendixes, a **Glossary**, and an **Index** are also provided.



WARNING Failure to read and understand the information provided in this manual may result in personal injury or death, damage to the product, or product failure. Please read each section in its entirety and be sure you understand the information provided in the section and related sections before attempting any of the procedures or operations given.

PRECAUTIONS

This section provides general precautions for using the Programmable Controller (PC) and related devices.

The information contained in this section is important for the safe and reliable application of the PC. You must read this section and understand the information contained before attempting to set up or operate a PC system.

1 Intended Audience	xii
2 General Precautions	xii
3 Safety Precautions	xii
4 Operating Environment Precautions	xii
5 Application Precautions	xiii
6 Conformance to EC Directives	xiv

1 Intended Audience

This manual is intended for the following personnel, who must also have knowledge of electrical systems (an electrical engineer or the equivalent).

- Personnel in charge of installing FA systems.
- Personnel in charge of designing FA systems.
- Personnel in charge of managing FA systems and facilities.

2 General Precautions

The user must operate the product according to the performance specifications described in the operation manuals.

Before using the product under conditions which are not described in the manual or applying the product to nuclear control systems, railroad systems, aviation systems, vehicles, combustion systems, medical equipment, amusement machines, safety equipment, and other systems, machines, and equipment that may have a serious influence on lives and property if used improperly, consult your OMRON representative.

Make sure that the ratings and performance characteristics of the product are sufficient for the systems, machines, and equipment, and be sure to provide the systems, machines, and equipment with double safety mechanisms.

This manual provides information for programming and operating OMRON PCs. Be sure to read this manual before attempting to use the software and keep this manual close at hand for reference during operation.

 **WARNING** It is extremely important that a PC and all PC Units be used for the specified purpose and under the specified conditions, especially in applications that can directly or indirectly affect human life. You must consult with your OMRON representative before applying a PC System to the abovementioned applications.

3 Safety Precautions

 **WARNING** Never attempt to disassemble any Units while power is being supplied. Doing so may result in serious electrical shock or electrocution.

 **WARNING** Never touch any of the terminals while power is being supplied. Doing so may result in serious electrical shock or electrocution.

4 Operating Environment Precautions

Do not operate the control system in the following places.

- Where the PC is exposed to direct sunlight.
- Where the ambient temperature is below 0°C or over 55°C.
- Where the PC may be affected by condensation due to radical temperature changes.
- Where the ambient humidity is below 10% or over 90%.
- Where there is any corrosive or inflammable gas.
- Where there is excessive dust, saline air, or metal powder.
- Where the PC is affected by vibration or shock.
- Where any water, oil, or chemical may splash on the PC.

-  **Caution** The operating environment of the PC System can have a large effect on the longevity and reliability of the system. Improper operating environments can lead to malfunction, failure, and other unforeseeable problems with the PC System. Be sure that the operating environment is within the specified conditions at installation and remains within the specified conditions during the life of the system.

5 Application Precautions

Observe the following precautions when using the PC.

-  **WARNING** Failure to abide by the following precautions could lead to serious or possibly fatal injury. Always heed these precautions.

- Always ground the system to 100 Ω or less when installing the system to protect against electrical shock.
- Always turn off the power supply to the PC before attempting any of the following. Performing any of the following with the power supply turned on may lead to electrical shock:
 - Mounting or removing any Units (e.g., I/O Units, CPU Unit, etc.) or memory cassettes.
 - Assembling any devices or racks.
 - Connecting or disconnecting any cables or wiring.

-  **Caution** Failure to abide by the following precautions could lead to faulty operation or the PC or the system or could damage the PC or PC Units. Always heed these precautions.

- Use the Units only with the power supplies and voltages specified in the operation manuals. Other power supplies and voltages may damage the Units.
- Take measures to stabilize the power supply to conform to the rated supply if it is not stable.
- Provide circuit breakers and other safety measures to provide protection against shorts in external wiring.
- Do not apply voltages exceeding the rated input voltage to Input Units. The Input Units may be destroyed.
- Do not apply voltages exceeding the maximum switching capacity to Output Units. The Output Units may be destroyed.
- Always disconnect the LG terminal when performing withstand voltage tests.
- Install all Units according to instructions in the operation manuals. Improper installation may cause faulty operation.
- Provide proper shielding when installing in the following locations:
 - Locations subject to static electricity or other sources of noise.
 - Locations subject to strong electromagnetic fields.
 - Locations subject to possible exposure to radiation.
 - Locations near to power supply lines.
- Be sure to tighten Backplane screws, terminal screws, and cable connector screws securely.
- Do not attempt to take any Units apart, to repair any Units, or to modify any Units in any way.

-  **Caution** The following precautions are necessary to ensure the general safety of the system. Always heed these precautions.

- Provide double safety mechanisms to handle incorrect signals that can be generated by broken signal lines or momentary power interruptions.
- Provide external interlock circuits, limit circuits, and other safety circuits in addition to any provided within the PC to ensure safety.

6 Conformance to EC Directives

Observe the following precautions when installing the C200HS-CPU01-EC and C200HS-CPU21-EC that conform to the EC Directives.

- 1, 2, 3...**
1. Since the C200HS PC is defined as an open type, be sure to install it inside a panel.
 2. Provide reinforced insulation or double insulation for the DC power source connected to the DC I/O Unit and for the CPU with a DC power source.
 3. The C200HS PC that conforms to the EC Directives also conforms, as an individual unit, to the Common Emission Standard (EN50081-2) of the EC Directives. When incorporated into a device, however, the C200HS PC may not satisfy this Standard due to the noise produced by the contact output when it switches on and off. In such a case, it will be necessary to take countermeasures such as connecting a surge or arc killer, or providing an external means of protection for the PC. The countermeasures taken to satisfy the Standard vary depending on the load devices, wiring, machinery configuration, etc. Described on page 130 are examples of countermeasures to be taken to reduce the noise.

Criteria for Taking Countermeasures

(Refer to EN50081-2 for details.)

Countermeasures are not required if the frequency of load switching for the whole system with the PC included is less than 5 times per minute.

Countermeasures are not required if the frequency of load switching for the whole system with the PC included is more than 5 times per minute.

SECTION 1

Introduction

This section provides general information about Programmable Controllers (PCs) and how they fit into a Control System. It also provides an overview of the new features of the C200HS and the major differences between the C200HS and the C200H.

1-1	What is a Control System?	2
1-2	The Role of the PC	4
1-2-1	Input Devices	4
1-2-2	Output Devices	4
1-3	How Does a PC Work?	5
1-4	New C200HS Features	8
1-4-1	Improved Memory Capabilities	8
1-4-2	Faster Execution Times	9
1-4-3	Larger Instruction Set	9
1-4-4	Expanded Number of I/O Points	9
1-4-5	Wide Selection of Special I/O Units	9
1-4-6	Improved Interrupt Functions	9
1-4-7	SYSMAC NET Link and SYSMAC LINK Capabilities	10
1-4-8	Built-in RS-232C Connector	10
1-4-9	More Flexible PC Settings	10
1-4-10	Debugging and Maintenance	10
1-4-11	Peripheral Devices	10
1-5	Comparisons Between C200HS and C200H	11
1-6	Compatibility of C200HS and C200H Devices	13

1-1 What is a Control System?

A Control System is the electronic equipment needed to control a particular process. It may include everything from a process control computer, if one is used, to the factory computer, down through the PCs (and there may be many of them networked together) and then on down through the network to the control components: the switches, stepping motors, solenoids, and sensors which monitor and control the mechanical operations.

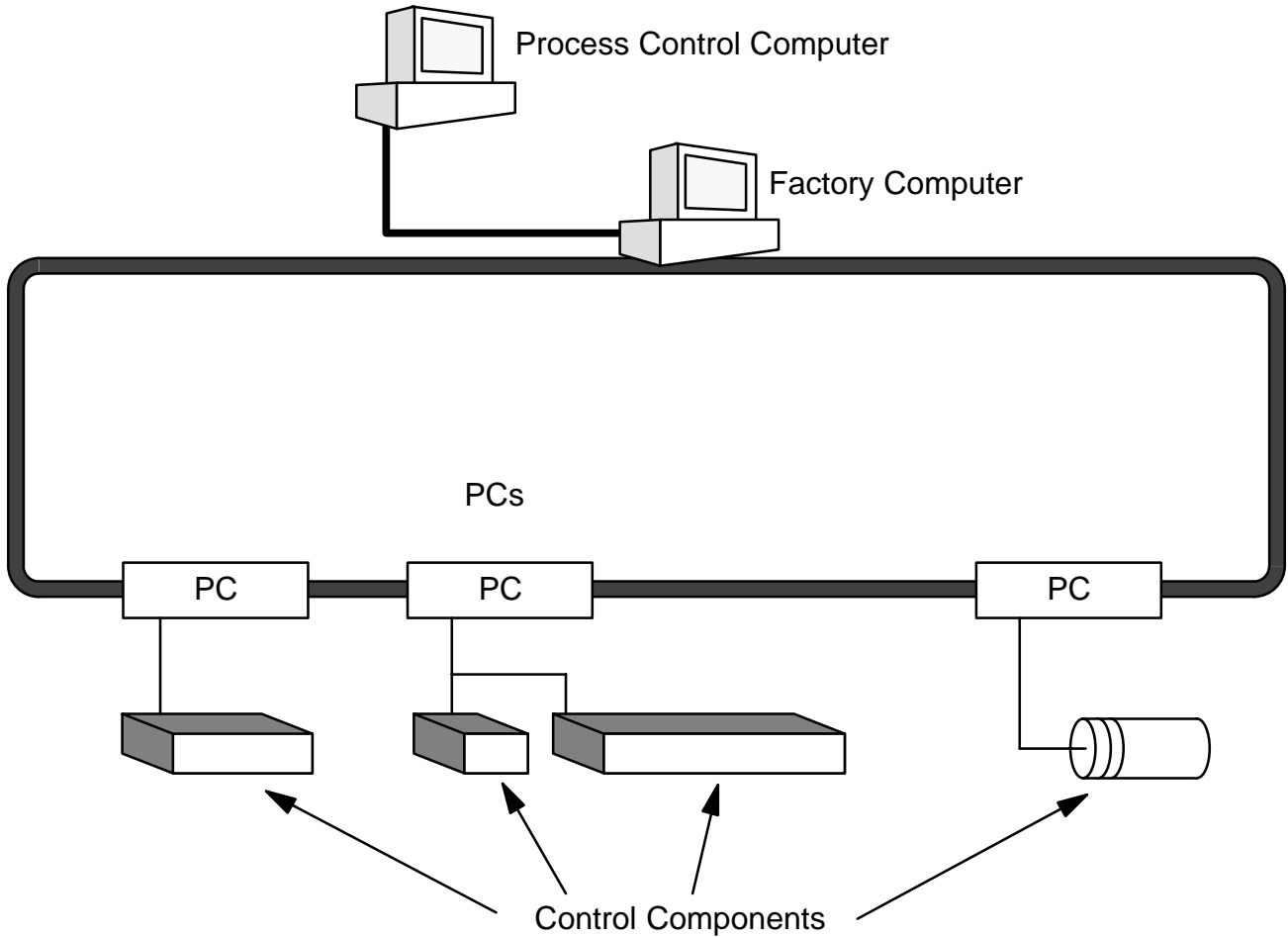

A Control System can involve very large applications where many different models of PC are networked together or it could be an application as small as a single PC controlling a single output device.

A Position Control System



In the typical Control System example shown above, a PC controls the movement of the workpiece bed across two horizontal axes using Limit Switches and Servomotors to monitor and control movement.

1-2 The Role of the PC

The Programmable Controller, or PC, is the part of the Control System that directly controls the manufacturing process. According to the program stored in its memory, the PC accepts data from the input devices connected to it, and uses this data to monitor the controlled system. When the program calls for some action to take place, the PC sends data to the output devices connected to it, to cause that action to take place. The PC may be used to control a simple, repetitive task, or it may be connected to other PCs, or to a host computer in order to integrate the control of a complex process.

1-2-1 Input Devices

PCs can receive input from either automated or manual devices. The PC could receive data from the user via a pushbutton switch, keyboard, or similar device. Automated input could come from a variety of devices: microswitches, timers, encoders, photosensors, and so on. Some devices, like the Limit Switch shown below, turn ON or OFF when the equipment actually makes contact with it. Other devices, like the Photoelectric Switch and Proximity Switch shown below, use other means, such as light or inductance, in order to get information about the equipment being monitored.

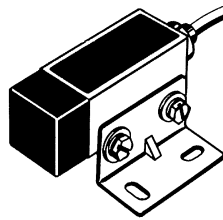

Photoelectric switch

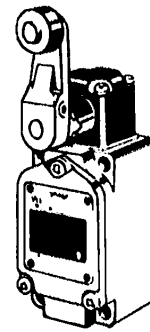

Limit switch



Proximity switch

1-2-2 Output Devices

A PC can output to a myriad of devices for use in automated control. Almost anything that you can think of could be controlled (perhaps indirectly) by a PC. Some of the most common devices are motors, Solenoids, Servomotors, Stepping Motors, valves, switches, indicator lights, buzzers, and alarms. Some of these output devices; such as the motors, Solenoids, Servomotors, Stepping Motors,

and valves; affect the controlled system directly. Others; such as the indicator lights, buzzers, and alarms; provide output to notify personnel.

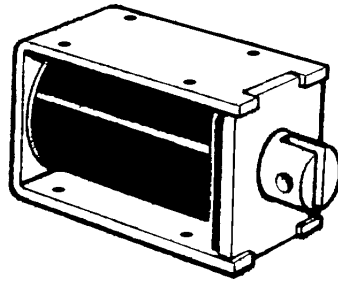

Solenoid



Servomotor

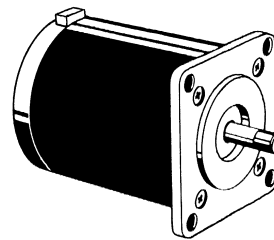

Stepping motor

1-3 How Does a PC Work?

PCs operate by monitoring input signals and providing output signals. When changes are detected in the signals, the PC reacts, through the user-programmed internal logic, to produce output signals. The PC continually scans the program in its memory to achieve this control.

Block Diagram of PC

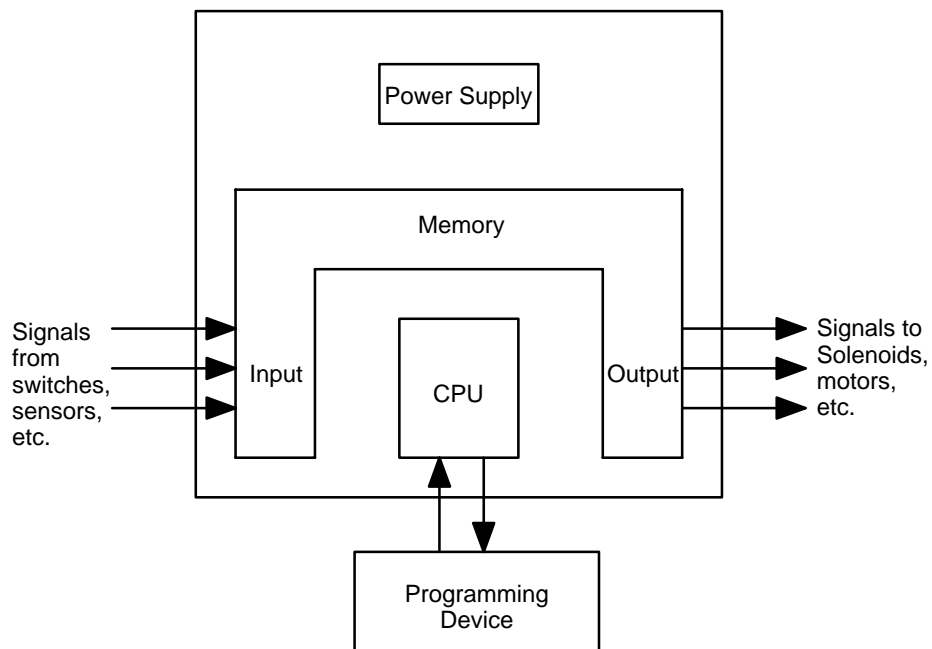

A program for your applications must be designed, and stored in the PC. This program is then executed as part of the cycle of internal operations of the PC.

Cycle

When a PC operates, that is, when it executes its program to control an external system, a series of operations are performed inside the PC. These internal operations can be broadly classified into the following four categories:

- 1, 2, 3...**
1. Common (or overseeing) processes, such as watchdog timer operation and testing the program memory.
 2. Data input and output.
 3. Instruction execution.
 4. Peripheral device servicing.

Cycle Time

The total time required for a PC to perform all these internal operations is called the cycle time. The flowchart and diagram on the following page illustrate these internal operations for a typical PC.

Timing is one of the most important factors in designing a Control System. For accurate operations, it is necessary to have answers to such questions as these:

- How long does it take for the PC to execute all the instructions in its memory?
- How long does it take for the PC to produce a control output in response to a given input signal?

The cycle time of the PC can be automatically calculated and monitored, but it is necessary to have an understanding of the timing relationships within the PC for effective system design and programming.

Flowchart of CPU Operation

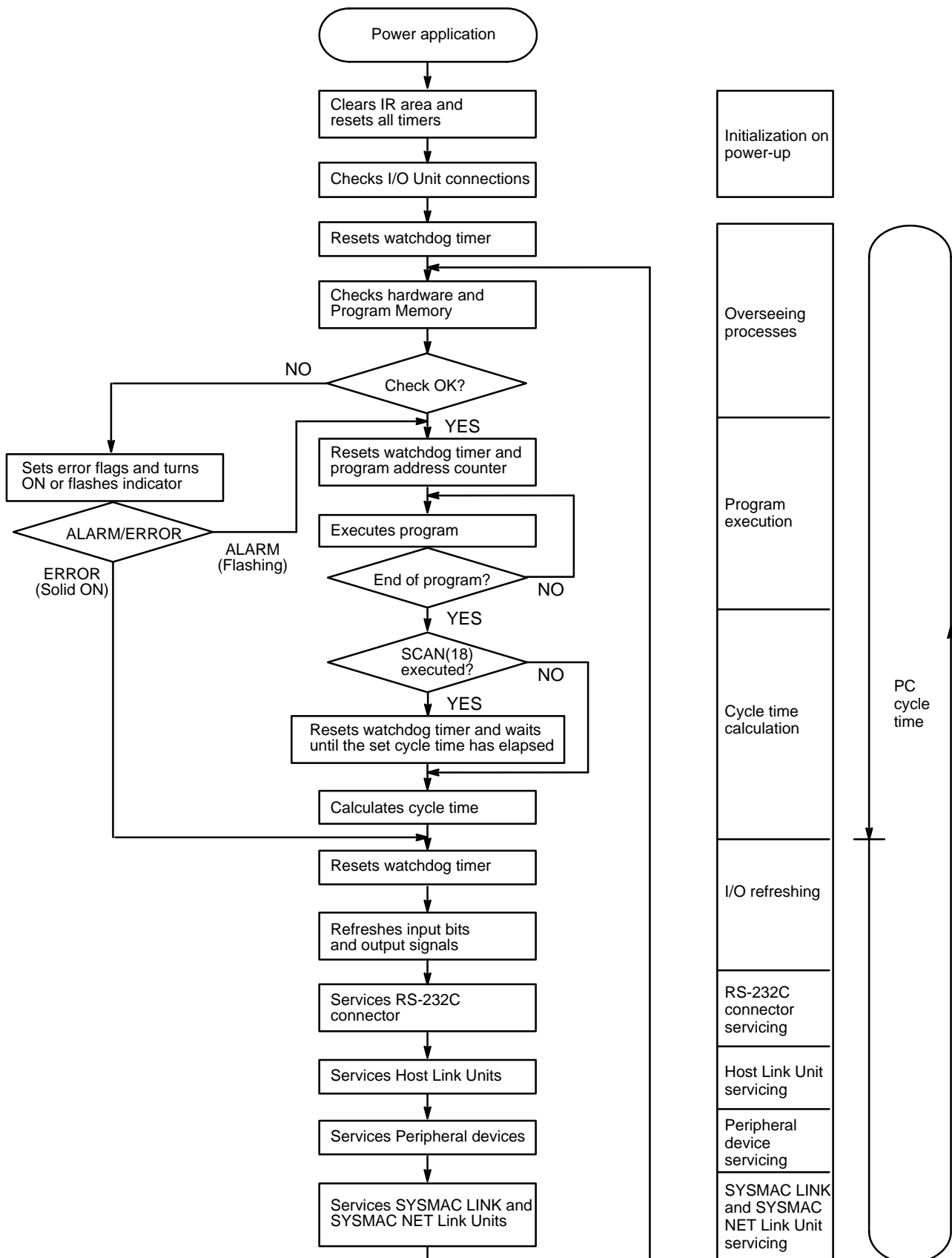

1-4 New C200HS Features

The C200HS CPUs (C200HS-CPU01-E, C200HS-CPU01-EC, C200HS-CPU03-E, C200HS-CPU21-E, C200HS-CPU23-E, C200HS-CPU31-E, and C200HS-CPU33-E) have a number of new features that the C200H CPUs lacked. The new C200HS features are described briefly in this section. The C200HS-CPU01-E, C200HS-CPU01-EC, C200HS-CPU21-E, and C200HS-CPU31-E use an AC power supply and the C200HS-CPU03-E, C200HS-CPU23-E, and C200HS-CPU33-E use DC.

In addition, the C200HS-CPU21-E, C200HS-CPU23-E, C200HS-CPU31-E, and C200HS-CPU33-E CPUs have an RS-232C connector. The C200HS-CPU31-E and C200HS-CPU33-E CPUs support the SYSMAC NET Link Unit and SYSMAC LINK Unit. The C200HS-CPU01-EC CPU and C200HS-CPU03-E CPU with lot number □□Z5 (Dec. 1995) or later conform to EC directives. The C200HS-CPU21-EC CPU conforms to EC directives.

1-4-1 Improved Memory Capabilities

Internal Memory (UM)

The C200HS CPUs come equipped with 16 KW of RAM in the PC itself, so a very large memory capacity is available without purchasing a separate Memory Unit. Furthermore, the program capacity has been increased to 15.2 KW.

Memory Cassettes

Two types of Memory Cassettes are available for storage of data such as the program. The PC can be set to transfer data from the Memory Cassette to UM automatically when the PC is turned on.

Model	Specifications
C200HS-ME16K	16-KW EEPROM
C200HS-MP16K	16-KW EPROM

Note C200H Memory Cassettes cannot be used in the C200HS.

Clock Function

The C200HS CPUs have a built-in clock. It is not necessary to purchase a Memory Unit equipped with a clock, as it was with the C200H-CPU21-E.

Increased SR and IR Areas

The SR area has been increased substantially to provide more work words and words dedicated to new instructions. The SR area now ranges from SR 236 to SR 299. (The SR area ends at SR 255 in C200H CPUs.)

The number of operands and instruction execution time will be increased when SR 256 to SR 299 are used in basic instructions.

I/O and work words previously ranged from 000 to 255. Words 256 to 511 have been added for the C200HS.

Increased DM Area

The Read/Write DM area has been increased substantially, too. It now ranges from DM 0000 to DM 6143, compared to DM 0000 to DM 0999 in C200H CPUs.

The 6000 words from DM 0000 to DM 5999 are available for use in the program. (DM 6000 to DM 6143 are used for the History Log and other functions.)

Fixed DM and Expansion DM Areas

The Fixed DM Area, used to store initializing data for Special I/O Units, has been decreased in size. It now contains the 512 words from DM 6144 to DM 6655, compared to 1000 words (DM 1000 to DM 1999) in C200H CPUs.

In addition, up to 3000 words of UM can be allocated as expansion DM. Expansion DM is allocated in 1000-word units in DM 7000 to DM 9999.

C200H data stored in words DM 1000 to DM 1999 can be used in C200HS PCs by converting these 1000 words to ROM in the C200HS's DM area (DM 7000 to DM 7999) and then automatically transferring them to DM 1000 to DM 1999 when the C200HS is turned on.

1-4-2 Faster Execution Times

Instruction Execution Time Basic instructions in the C200HS are executed in as little as $\frac{1}{2}$ of the time required in the C200H. Other instructions are executed in just $\frac{1}{3}$ to $\frac{1}{8}$ of the time.

END Processing Time The time required for the cycle's overhead processes depend on the system configuration, but these processes are executed in about $\frac{1}{4}$ of the time required in the C200H.

I/O Refreshing Time The I/O refreshing time has been reduced for all units, as shown in the following table.

I/O Unit	Time Required for Refreshing
Standard I/O Units	$\frac{1}{3}$ of the C200H I/O refreshing time
Group-2 High-density I/O Units	$\frac{1}{3}$ of the C200H I/O refreshing time
Special I/O Units	$\frac{4}{5}$ of the C200H I/O refreshing time

1-4-3 Larger Instruction Set

Advanced programming is facilitated by the 225 special instructions available with the C200HS-CPU01-E, C200HS-CPU01-EC, C200HS-CPU03-E, C200HS-CPU21-E, C200HS-CPU21-EC, and C200HS-CPU23-E, or the 229 special instructions available with the C200HS-CPU31-E and C200HS-CPU33-E. In addition, programming has been simplified by the addition of convenient instructions and macro functions. The new instructions and functions are covered in detail in the *C200HS Operation Manual (W235)*.

1-4-4 Expanded Number of I/O Points

Two Expansion I/O Racks can be connected to a CPU Rack to comprise a total of three Racks. This allows for a total of 240 I/O points, for example, when 8-point I/O Units are used, or 480 I/O points when 16-point I/O Units are used.

In addition, a Remote I/O System can provide a maximum of 800 points with Slave Units or 512 points with Optical I/O Units.

1-4-5 Wide Selection of Special I/O Units

C200HS Systems can be configured in a variety of ways, using High-density I/O Units, High-speed Counters, Position Control Units, Analog I/O Units, Temperature Sensor Units, ASCII Units, Voice Units, ID Sensor Units, Fuzzy Logic Units, Cam Positioner Units, and so on.

1-4-6 Improved Interrupt Functions

Scheduled Interrupts The C200HS's scheduled interrupt function has been improved so that the interrupt interval can be set in 1 ms units rather than the 10 ms units in the C200H. When the interrupt mode is set to C200HS mode, the interrupt response time is only 1 ms max. (excluding the input ON/OFF delays). When a Communications Unit is used with the C200HS-CPU31-E/CPU33-E CPU, the interrupt response time is 10 ms max.

Input Interrupts Up to 8 interrupt subroutines can be executed by inputs to a C200HS-INT01 Interrupt Input Unit mounted to the C200HS. When the interrupt mode is set to C200HS mode, the interrupt response time is only 1 ms max. (excluding the input ON/OFF delays). When a Communications Unit is used with the C200HS-CPU31-E/CPU33-E CPU, the interrupt response time is 10 ms max.

1-4-7 SYSMAC NET Link and SYSMAC LINK Capabilities

The SYSMAC NET Link and SYSMAC LINK Systems are high-speed FA networks which can be used with the C200HS-CPU31-E and C200HS-CPU33-E CPUs and the following Units:

SYSMAC NET Link Unit:	C200HS-SNT32
SYSMAC LINK Units:	C200HW-SLK13/SLK14 (optical fiber cable) C200HW-SLK23/SLK24 (coaxial cable)

Data can be exchanged with the PCs in a SYSMAC NET Link or SYSMAC LINK System using the SEND and RECV instructions.

1-4-8 Built-in RS-232C Connector

Host link communications are possible using the RS-232C connector built into the C200HS-CPU21-E/CPU21-EC/CPU23-E/CPU31-E/CPU33-E CPU. By using the TXD and RXD instructions, RS-232C communications is possible without using time-consuming procedures. A 1-to-1 link using the LR Area or an NT link with the Programmable Terminal (PT) allows high-speed communications.

1-4-9 More Flexible PC Settings

With its default settings, the C200HS can be used like a C200H PC, but the C200HS's new settings provide more flexibility and allow it to be adjusted to fit particular applications. These new settings are described below.

DIP Switch Settings

The 6 pins on the C200HS's DIP switch are used to write-protect part of UM, set the CPU to automatically transfer Memory Card data to UM, and other functions.

UM Area Allocation

Portions of the UM area can be allocated for use as the Expansion DM Area and I/O Comment Area. (Most of the UM area is used to store the ladder program.)

PC Setup

DM 6600 to DM 6655 is set aside for PC Setup data. The PC Setup determines many operating parameters, including the startup mode and initial Special I/O Unit area.

1-4-10 Debugging and Maintenance

New functions such as data trace and differential monitor have been added, making it easier to check status changes. These and other new functions are covered in detail in the *C200HS Operation Manual (W235)*.

1-4-11 Peripheral Devices

Peripheral Device Connection

With the C200H, Peripheral Devices had to be connected through a Peripheral Interface Unit or Host Link Unit, but with the C200HS Peripheral Devices can be connected to the PC through a CQM1-CIF02 Connecting Cable.

I/O Comments Stored in PC

By allocating a part of UM as the I/O Comment area, it is no longer necessary to read I/O Comments from a Peripheral Device's floppy disk. If the Peripheral Device is connected to the C200HS online, the ladder diagram can be viewed with I/O comments.

Online Editing

A "CYCLE TIME OVER" error will no longer be generated when the program in the PC itself is being edited online.

1-5 Comparisons Between C200HS and C200H

The following table outlines the main upgrades that have been made, and the differences in functions and performance between the C200HS and the C200H.

Function	Model	
	C200HS	C200H
Memory		
Built-in UM capacity	RAM: 16K words (Program capacity: 15.2K words)	None (Memory Unit used.)
Optional memory	Memory Cassette (backup, storage)	Memory Unit (for loading, storing UM)
EEPROM	C200HS-ME 16K (16K words)	C200H-ME431/2 (4K words) C200H-ME831/2 (8K words)
EPRM	C200HS-MP 16K (16K words)	C200H-MP831 (8K words)
RAM	---	C200H-MR431/2/3 (4K words) C200H-MR831/2/3 (8K words)
I/O memory		
IR memory	3,296 bits (03000 to 23515) 3,392 bits (30000 to 51115)	3,296 bits (03000 to 23515)
SR memory	312 bits (23600 to 25507) 704 bits (25600 to 29915)	312 bits (23600 to 25507)
Data Memory		
Normal DM	6,144 words (DM 0000 to DM 6143)	1,000 words (DM 0000 to DM 0999)
Fixed DM	512 words (DM 6144 to DM 6655)	1,000 words (DM 1000 to DM 1999)
Expansion DM	0 to 3,000 words (DM 7000 to DM 9999)	---
Clock function	Standard for all models.	Standard for CPU11-E/31-E. Included in Memory Unit for C200HS-CPU21-E/22-E/23-E.
Execution time		
Instruction execution time		
Basic instructions	0.375 to 1.125 μ s	0.75 to 2.25 μ s
Special instructions	Approx. 1/4 that of the C200H.	34 to 724 μ s
Common processing time (END processing time)	0.7 ms	2.8 ms
I/O refresh time		
Basic I/O	Approx. 1/3 that of the C200H.	0.04 to 0.07 ms/8 bits
High-density I/O (Group 2)	Approx. 1/3 that of the C200H.	0.34 to 0.86 ms/Unit
Special I/O	Approx. 4/5 that of the C200H.	0.8 to 6.5 ms/Unit
Instructions		
Number of instructions	225 (229 for the CPU31-E/CPU33-E)	168 (172 for the CPU31-E)
Basic instructions	14 (SET/RSET added)	12
Special instructions	211 (215 for the CPU31-E/CPU33-E)	156 (160 for the CPU31-E)
Setting functions	UM area arrangement PC operation setting switch Special instruction settings PC Setup	---

Function	Model	
	C200HS	C200H
Interrupt function		
Scheduled interrupts		
Interrupt period	10 ms x SV or 1 ms x SV	10 ms x SV
Interrupt response time	10 ms max. (C200H common mode, Communications Unit connected) 1 ms (C200HS mode, Communications Unit not connected)	10 ms max.
Input interrupts	8 points max.	
Interrupt Input Unit	C200HS-INT01 (8 points)	No interrupt input function
Backplane	C200H-BC□□1-V2 (corresponding to Interrupt Input Unit)	C200H-BC□□1-V1 (Interrupt Input Unit not possible.)
Interrupt response time	1 ms max. (10 ms max. when Communications Unit connected)	
Debugging and maintenance	Forced set/reset Data trace Differential monitor	Forced set/reset
Programming Console operations	Decimal display of binary data Continuation of display when modes are switched Terminal mode and expansion terminal mode	Terminal mode
Peripheral Devices		
Connection method	Direct connection to C200HS.	Connection via Peripheral Interface Unit or Host Link Unit.
Cable for personal computer	CQM1-CIF02	
SYSMAC Support Software (SSS)	C500-ZL3AT1-E	C500-ZL3AT1-E
I/O comments	Can be stored in C200HS	
Online editing	Cycle time over non-detection setting possible.	
Communications Units	For C200HS-CPU31-E/CPU33-E	
SYSMAC NET Link	C200HS-SNT32	C200H-SNT31
SYSMAC LINK	C200HW-SLK13/SLK14 (Optical) C200HW-SLK23/SLK24 (Coaxial)	C200H-SLK11 C200H-SLK21-V1
Built-in Host Link	RS-232C connector built into the C200HS-CPU21-E/CPU21-EC/ CPU23-E/CPU31-E/CPU33-E	---
1-to-1 link	LR Area is shared by connecting RS-232C connectors.	
NT link	High-speed communications with Programmable Terminal (PT) via RS-232C connector.	
Host Link Units		
Added function	Transmission possible by means of TXD instruction.	
Optical cable	C200H-LK101-PV1	C200H-LK101-P
RS-232C	C200H-LK201-V1	C200H-LK201
RS-422	C200H-LK202-V1	C200H-LK202

1-6 Compatibility of C200HS and C200H Devices

Completely compatible: C200H devices can be used with the C200HS as is.

Replacement Units: These Units were developed for the C200HS and can be used for both the C200H and the C200HS.

C200HS only: These devices can only be used with the C200HS.

Classification	Type of Unit	Completely compatible	Replacement Units	C200HS only	Remarks
CPU Rack	CPU			Yes	C200HS-CPU01-E/01-EC/03-E/21-E/21-EC/23-E/31-E/33-E
	Backplane		Yes		C200H-BC031-V2/051-V2/081-V2/101-V2 (Existing Backplanes can be used if Interrupt Input Units are not used.)
	Memory Cassette			Yes	C200HS-ME16K/MP16K
Expansion I/O Rack		Yes			Configured based on Backplane and I/O Power Supply Unit.
I/O Connecting Cable		Yes			One cable is required to connect one Expansion I/O Rack.
I/O Unit	8/12/16-pt. I/O Units	Yes			
	Standard B7A Interface Units	Yes			16 pts.
	Group-2 High-density I/O Unit and Group-2 B7A Interface Units	Yes			32 pts. or 64 pts.
	Special I/O Unit	Yes			High-speed Counters, Position Control Units, High-density I/O Units, Analog I/O Units, Temperature Sensor Units, ASCII Units, etc.
	Interrupt Unit			Yes	When mounting an Interrupt Input Unit, use the C200H-BC□□1-V2.
Remote I/O (Optical)	Master Unit	Yes			C200H-RM001-PV1
	Slave Unit	Yes			C200H-RT001-P/002-P
Remote I/O (Wired)	Master Unit	Yes			C200H-RM201
	Slave Unit	Yes			C200H-RT201/201-C/202
Link	Host Link Unit		Yes		C200H-LK101-PV1 C200H-LK201-V1 C200H-LK202-V1
	PC Link Unit	Yes			C200H-LK401
	SYSMAC LINK		Yes		C200HW-SLK13/SLK14 C200HW-SLK23/SLK24
	SYSMAC NET Link		Yes		C200HS-SNT32
Peripheral Device	Programming Console	Yes			C200H-PRO27-E CQM1-PRO01-E
	SSS	Yes			C500-ZL3AT1-E

SECTION 2

System Configuration and Unit Description

This section provides information about the Racks and individual Units that make up a C200HS PC System. The names of all the parts of a Unit are given, followed by any details that apply to that Unit alone. For a description of how the Units fit together to become a PC, refer to *Section 3 Assembly Instructions*. For information about the model numbers of any of the parts described in this section, refer to *Appendix A Standard Models*. For specifications, refer to *Appendix B Specifications*.

2-1	System Configuration	16
2-1-1	CPU Racks	16
2-1-2	Expansion I/O Racks	17
2-1-3	Slave Racks	17
2-2	CPUs	18
2-2-1	CPU Components	18
2-2-2	CPU Indicators	19
2-2-3	Power Supply	20
2-2-4	DIP Switch	22
2-2-5	Peripheral Device Connector	22
2-2-6	Operation Modes	23
2-2-7	Memory Cassettes	23
2-3	Expansion I/O Racks	24
2-4	Power Supply Unit	25
2-5	I/O Units	26
2-5-1	Standard I/O Units	27
2-5-2	Group-2 High-density I/O Units	28
2-5-3	High-density I/O Units Classified as Special I/O Units	30

2-1 System Configuration

A variety of system configurations can be achieved by using different combinations of Racks and Units. Before ordering specific Units, carefully consider which system configuration will best meet your control requirements. In a C200HS PC System, a maximum of two Expansion I/O Racks and five Remote I/O Slave Racks can be connected to a CPU Rack.

2-1-1 CPU Racks

A CPU Rack consists of the CPU, I/O Units, and other Units mounted to a CPU Backplane. An example is shown below.



1. Backplane

There are backplanes available with 3, 5, 8, or 10 slots. The same backplanes can be used for CPU Racks, Expansion I/O Racks, or Slave Racks.

2. CPU

There are eight CPU models available: CPU01-E, CPU01-EC, CPU03-E, CPU21-E, CPU21-EC, CPU23-E, CPU31-E, and CPU33-E.

3. Battery and DIP Switch Compartment

An optional Memory Cassette can also be added here. EPROM and EEPROM Memory Cassettes are both available.

4. Standard I/O Unit

The Units can have 5, 8, 12, or 16 points. In this illustration the I/O Unit cover is mounted. This is the terminal block cover for Units with 10P terminal blocks.

5. Interrupt Input Unit

One Interrupt Input Unit can be used at the CPU Rack.

6. and 7. SYSMAC NET Link/SYSMAC LINK Unit, Host Link Unit, PC Link Unit Remote I/O Master Unit

A maximum of two Units can be used of each of these Units, either on the CPU Rack or on an Expansion I/O Rack.

SYSMAC NET Link/SYSMAC LINK Units can be mounted only to C200HS-CPU31-E/CPU33-E CPUs. Bus Connection Units are required to connect to the CPU and a Power Supply Adapter/Auxiliary Power Supply Unit must be mounted next to the Unit.

8. Standard I/O Unit

Terminal blocks have either 10 or 19 terminals. This is a 19P terminal block.

9. High-density I/O Unit (Group 2) or Group-2 B7A Interface Unit

A maximum of ten Units can be used if they are all 32-point Units, and five if they are all 64-point Units. They cannot be used on Slave Racks.

10. Special I/O Unit

Up to ten Special I/O Units can be used (including PC Link). They can be used on any Rack.

2-1-2 Expansion I/O Racks

An Expansion I/O Rack consists of an I/O Power Supply Unit and I/O Units mounted to a Backplane. A maximum of two Expansion I/O Racks can be connected. The same Expansion I/O Racks can be connected to either C200H or C200HS CPU Racks via an I/O Connecting Cable.

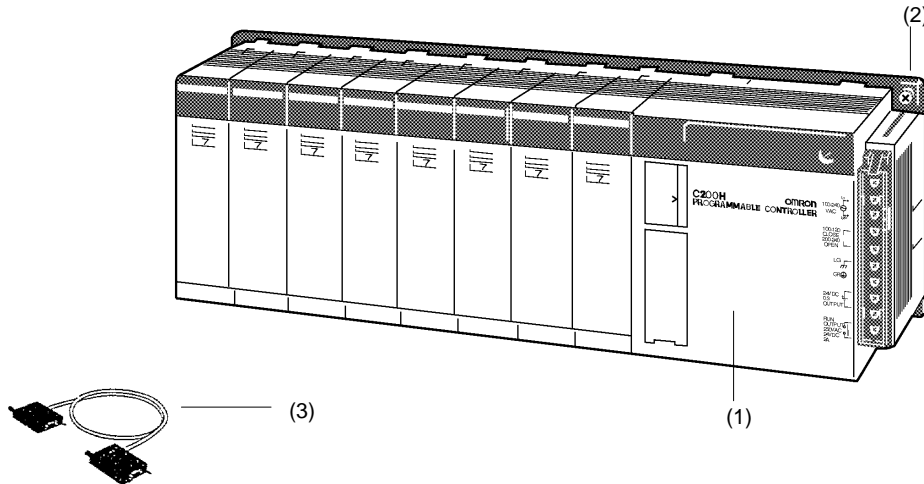

1. I/O Power Supply Unit

2. Backplane

There are backplanes available with 3, 5, 8, or 10 slots. The same backplanes can be used for CPU Racks, Expansion I/O Racks, or Slave Racks.

3. I/O Connecting Cable

There are five types of cable, from 30 cm to 10 m. A maximum total of 12 m can be used.

2-1-3 Slave Racks

A Slave Rack consists of an Remote I/O Slave Unit and I/O Units mounted to a Backplane. A maximum of five Slave Racks can be connected. Slave Racks are connected via either optical or wire cables to a Remote I/O Master Unit mounted to the CPU Rack.

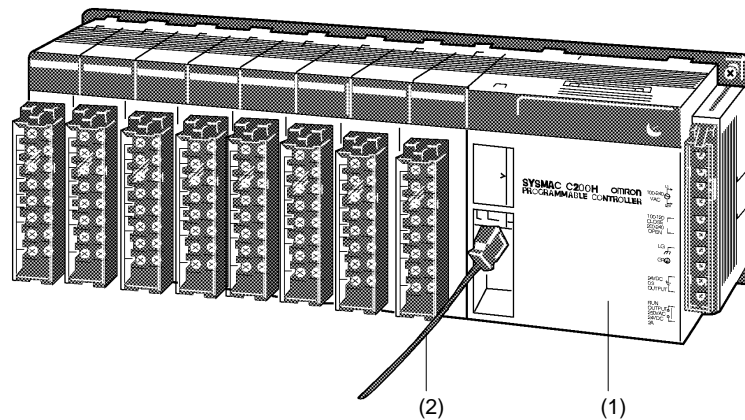

1. Slave Unit

Either Optical or Wired Slaves can be used.

2. Fiber-optic Cable

2-2 CPUs

There are two groups of CPUs available, one that uses an AC power supply, and one that uses a DC power supply. Select one of the models shown below according to requirements of your control system.

CPU model	Power supply voltage
C200HS-CPU01-E/CPU01-EC/CPU21-E /CPU21-EC/CPU31-E	100 to 120 VAC or 200 to 240 VAC (voltage selector)
C200HS-CPU03-E/CPU23-E/CPU33-E	24 VDC

The CPU21-E, CPU23-E, CPU31-E, and CPU33-E CPUs have an RS-232C connector. The CPU31-E and CPU33-E CPUs support the SYSMAC NET Link Unit and SYSMAC LINK Unit. The C200HS-CPU01-EC CPU and C200HS-CPU03-E CPU with lot number □□Z5 (Dec. 1995) or later conform to EC directives. The C200HS-CPU21-EC CPU conforms to EC directives.

Caution Be sure to check the power supply used by the CPU. Absolutely do not apply an AC power supply to a DC-type CPU.

2-2-1 CPU Components

C200HS-CPU01-E/CPU01-EC/CPU03-E

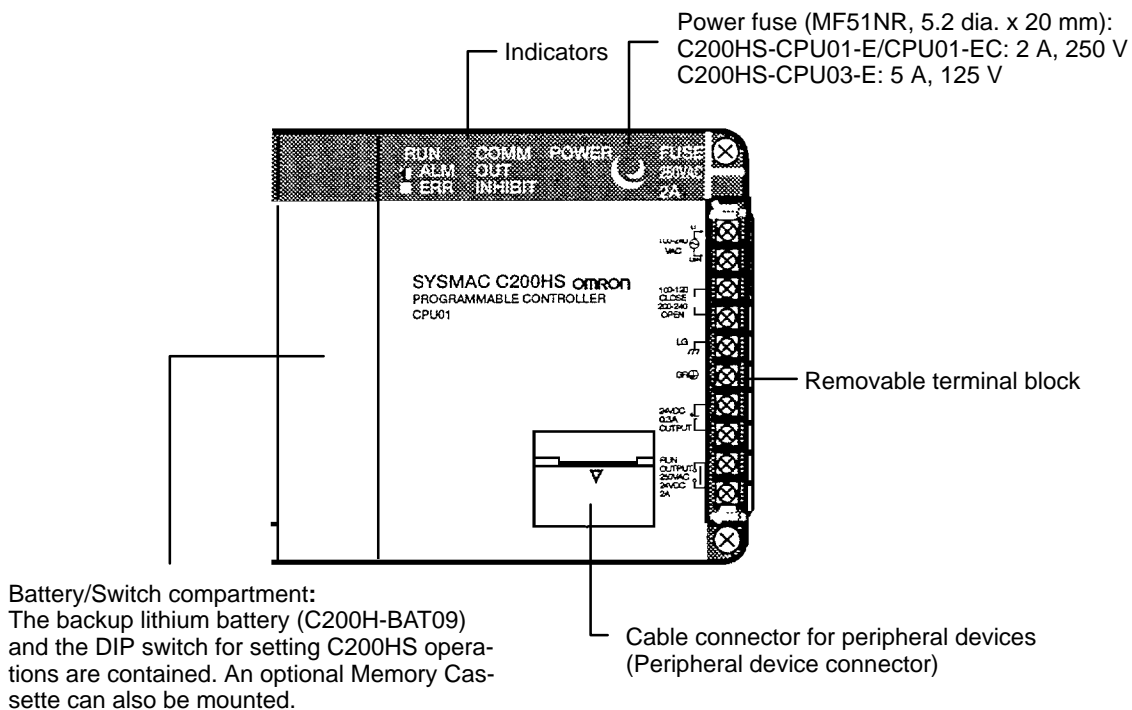

C200HS-CPU21-E/CPU21-EC/CPU23-E/CPU31-E/CPU33-E

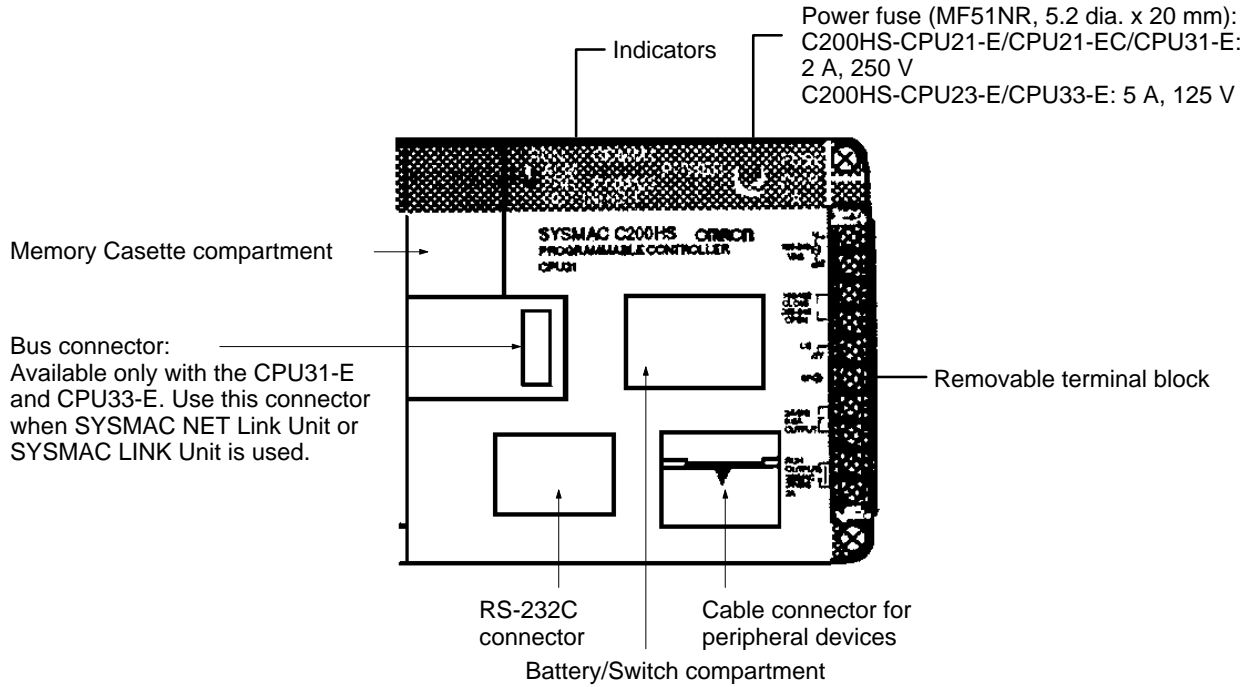

2-2-2 CPU Indicators

The following table shows the indicators that are located on the front panel of the CPUs.



2-2-3 Power Supply

AC Power Supplies:

C200HS-CPU01-E/CPU21-E/CPU31-E

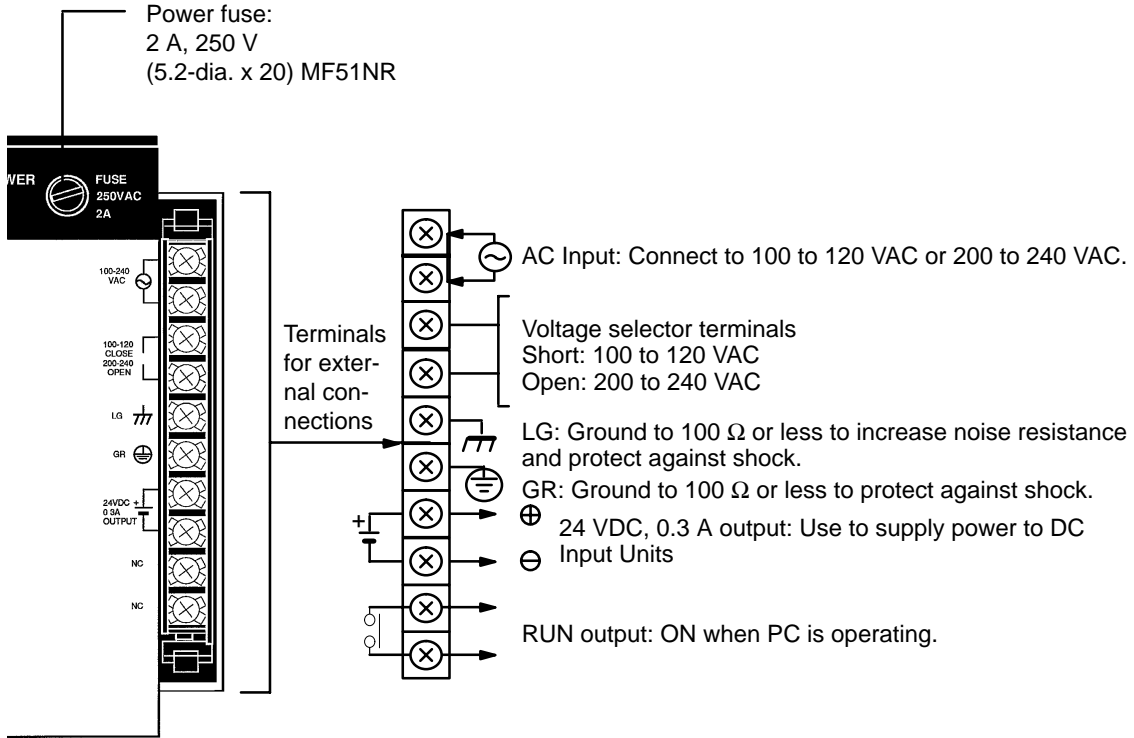

C200HS-CPU01-EC/CPU21-EC

Conforms to EC directives.

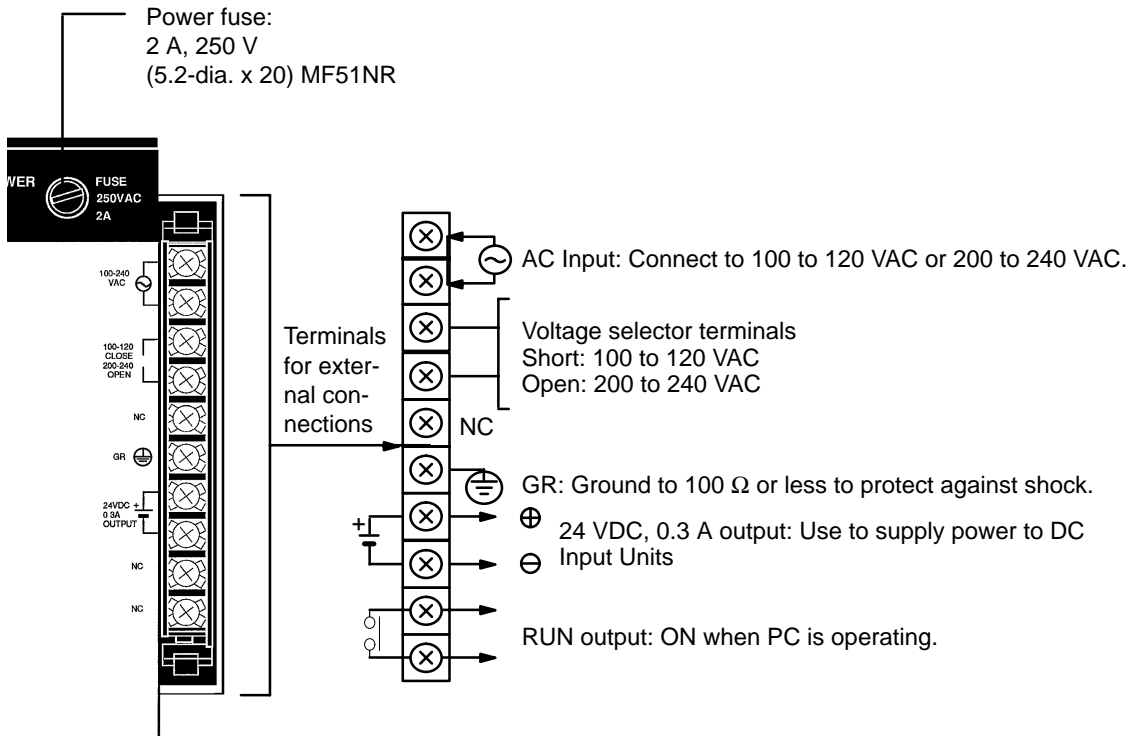

DC Power Supplies: C200HS-CPU23-E/CPU33-E

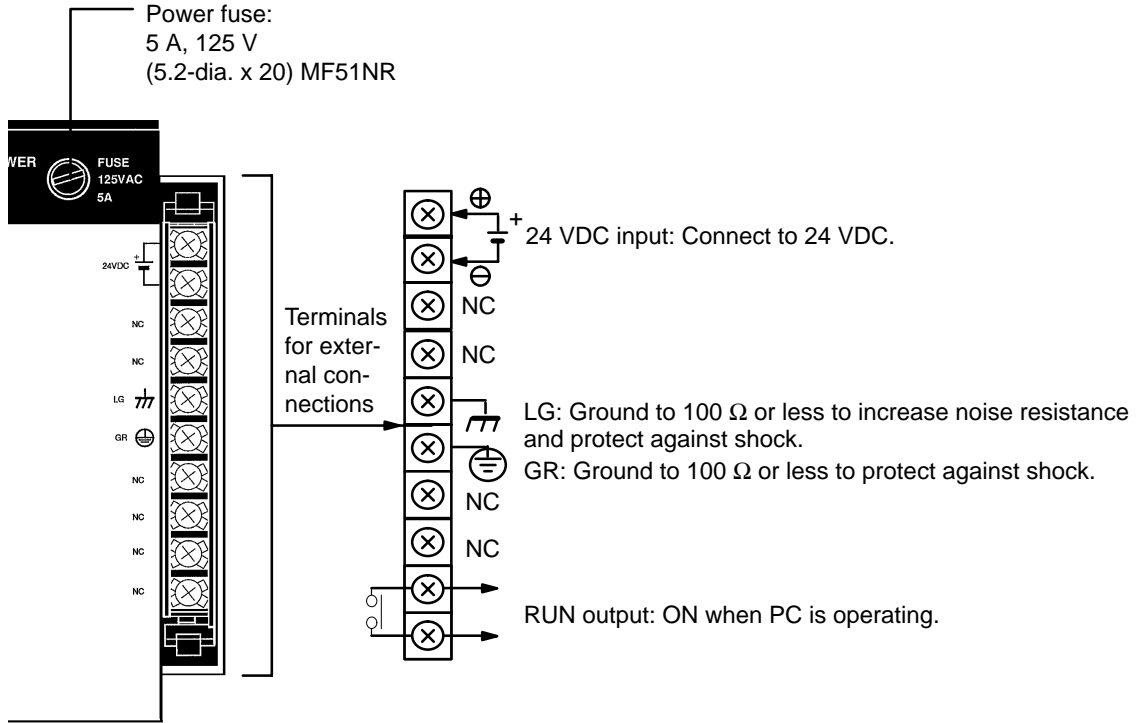

C200HS-CPU03-E

CPU_s with lot numbers □□Z5 (Dec. 1995) or later conform to EC directives.

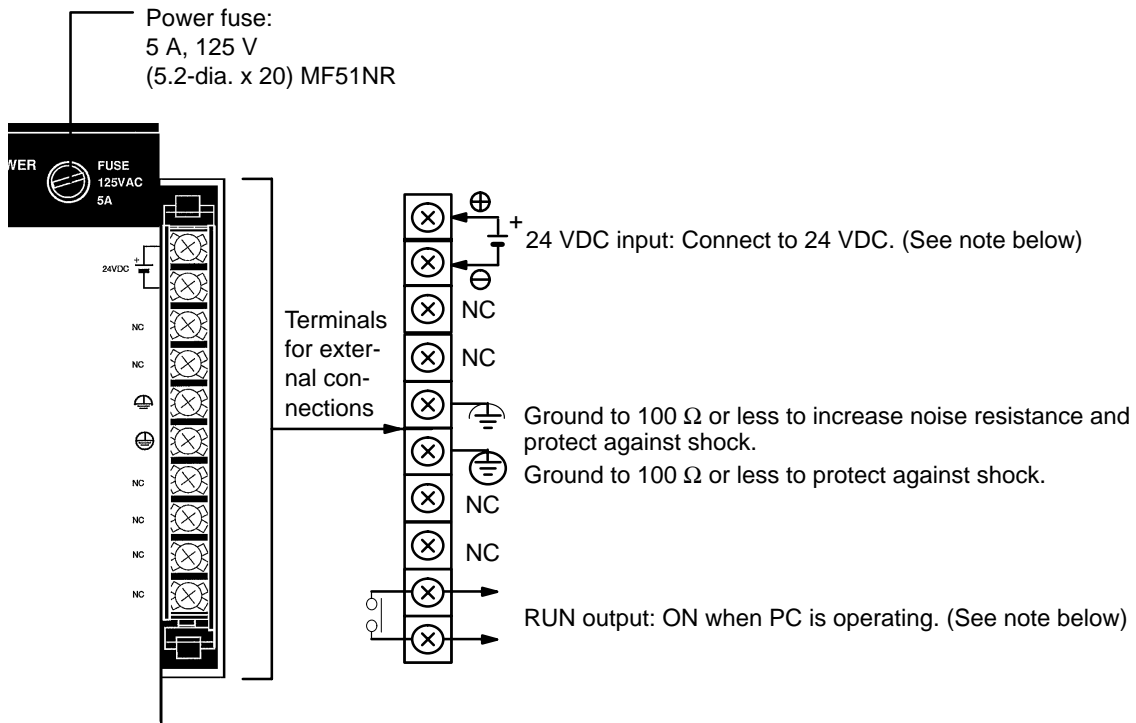

Note Use a 24-VDC power supply with reinforced insulation or double insulation if the EC directives (low-voltage directives) must be satisfied.

2-2-4 DIP Switch

All the DIP switch settings are factory-set to OFF. Set them as required depending on the use.

Pin no.	Item	Setting	Function
1	Memory protect	ON	Program Memory and read-only DM (DM 6144 to DM 6655) data cannot be overwritten from a Peripheral Device.
		OFF	Program Memory and read-only DM (DM 6144 to DM 6655) data can be overwritten from a Peripheral Device.
2	Automatic transfer of Memory Cassette contents (see note 1)	ON	The contents of the Memory Cassette will be automatically transferred to the internal RAM at start-up.
		OFF	The contents will not be automatically transferred.
3	Message language	ON	Programming Console messages will be displayed in English.
		OFF	Programming Console messages will be displayed in Japanese.
4	Expansion instruction setting	ON	Expansion instructions set by user. Normally ON when using a host computer for programming/monitoring.
		OFF	Expansion instructions set to defaults.
5	Communications conditions (see note 2)	ON	Standard communications parameters (see note) will be set for the following serial communications ports. <ul style="list-style-type: none"> Built-in RS-232C port Peripheral port (only when a connecting cable for a personal computer (for example, the CQM1-CIF01/-CIF02 Cable) is connected) <p>Note</p> <ol style="list-style-type: none"> Standard communications parameters are as follows: Serial communications mode: Host Link or peripheral bus; start bits: 1; data length: 7 bits; parity: even; stop bits: 2; baud rate: 9,600 bps The CX-Programmer running on a personal computer can be connected to the peripheral port via the peripheral bus using the above standard communications parameters.
		OFF	The communications parameters for the following serial communications ports will be set in PC Setup as follows: <ul style="list-style-type: none"> Built-in RS-232C port: DM 6645 and DM 6646 Peripheral port: DM 6650 and DM 6651 <p>Note</p> <p>When the CX-Programmer is connected to the peripheral port with the peripheral bus, either set bits 00 to 03 of DM 6650 to 0 Hex (for standard parameters), or set bits 12 to 15 of DM 6650 to 0 Hex and bits 00 to 03 of DM 6650 to 1 Hex (for Host Link or peripheral bus) separately.</p>
6	Expansion TERMINAL mode setting	ON	Expansion TERMINAL mode (when AR 0709 is ON); AR 0712: ON
		OFF	Normal mode; AR 0712: OFF

- Note**
- The Memory Cassette is optional.
 - The values shown in the above table for the ON status of the communications conditions apply to CPUs with the lot number "□□75" (July 1995) or those manufactured afterward. The values for CPUs with the lot number "□□65" (June 1995) or those manufactured before then are as follows; stop bit: 1 and baud rate: 2,400 bps.

2-2-5 Peripheral Device Connector

A Programming Console (C200H-PRO27-E or CQM1-PRO01-E) or IBM PC/AT running LSS can be used to program and monitor the C200HS PCs. They can be connected by opening the cover and connecting a cable to the peripheral device connector.

Use the following cables to connect the respective Peripheral Devices.

Programming Console: C200H-CN222/CN422
C200HS-CN222/CN422
(Conforms to EC directives)

IBM PC/AT: CQM1-CIF02

(The C200H-CN222 Connecting Cable is included with the CQM1-PRO01-E Programming Console.)

Note Peripheral Devices can be mounted directly to C200H PCs, but not to C200HS PCs.

2-2-6 Operation Modes

The operation modes when the C200HS is powered up are shown in the table below. If a Peripheral Device is connected when the C200HS power is already on, the mode status prior to connecting the Peripheral Device will be retained.

PC Setup (DM 6600) status	Peripheral Device connected	C200HS mode at power up
Mode according to status of Programming Console keys (DM 6600 = 0000)	None	Automatically goes into RUN mode.
	Programming Console	Goes into mode set by Programming Console selector switch.
	Device other than Programming Console	Automatically goes into PROGRAM mode.
Mode retained from before power interruption (DM 6600 = 0100)	None	Goes into mode that was in effect prior to power interruption.
	Programming Console	
	Device other than Programming Console	
Mode according to PC Setup DM 6600 = 0200: PROGRAM DM 6600 = 0201: MONITOR DM 6600 = 0202: RUN	None	Goes into mode set by PC Setup (bits 00 to 07 of DM 6600).
	Programming Console	
	Device other than Programming Console	

2-2-7 Memory Cassettes

The C200HS comes equipped with a built-in RAM for the user's program, so a normal program can be created even without installing a Memory Cassette. An optional Memory Cassette, however, can provide greater speed and flexibility. There are two types of Memory Cassette available, each with a capacity of 16K words. For instructions on installing Memory Cassettes, refer to *Section 3 Installation*.

The following table shows the Memory Cassettes which can be used with the C200HS PCs. These Memory Cassettes cannot be used in C200H PCs.

Memory	Capacity	Model number	Comments
EEPROM	16K words	C200HS-ME16K	---
EPROM	16K words	C200HS-MP16K	The ROM chip is not included with the Memory Cassette; it must be purchased separately.

Note Memory Cassettes for the C200HS cannot be used with the C200H, and Memory Units for the C200H cannot be used with the C200HS.

C200HS-ME16K (EEPROM)

When a Memory Cassette is installed in the CPU, reading and writing of the user memory (UM) and I/O data is made possible. There is no need for a

backup power supply. The Memory Cassette can be removed from the CPU and used for storing data.

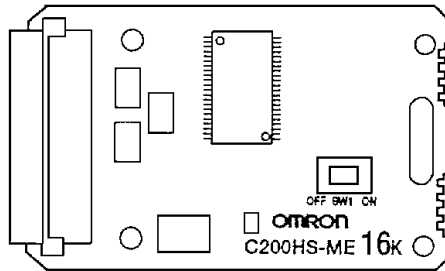

C200HS-MP16K (EPROM)

The program is written using a PROM Writer. The ROM is mounted to the Memory Cassette and then installed in the CPU. I/O data cannot be stored.

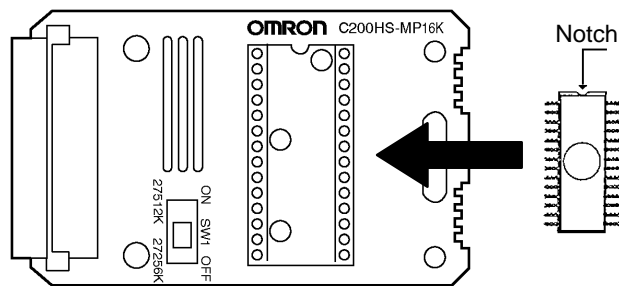

2-3 Expansion I/O Racks

The Backplane used to construct a CPU Rack is also used to construct an Expansion I/O Rack. An Expansion I/O Rack is identical to a CPU Rack, except the CPU is replaced with a Power Supply. Two Expansion I/O Racks can be connected to a CPU Rack. The number of I/O Units and Special I/O Units that can be connected to an Expansion I/O Rack is determined by the number of slots on the Rack.

The parts of an Expansion I/O Rack are shown in the following diagram.

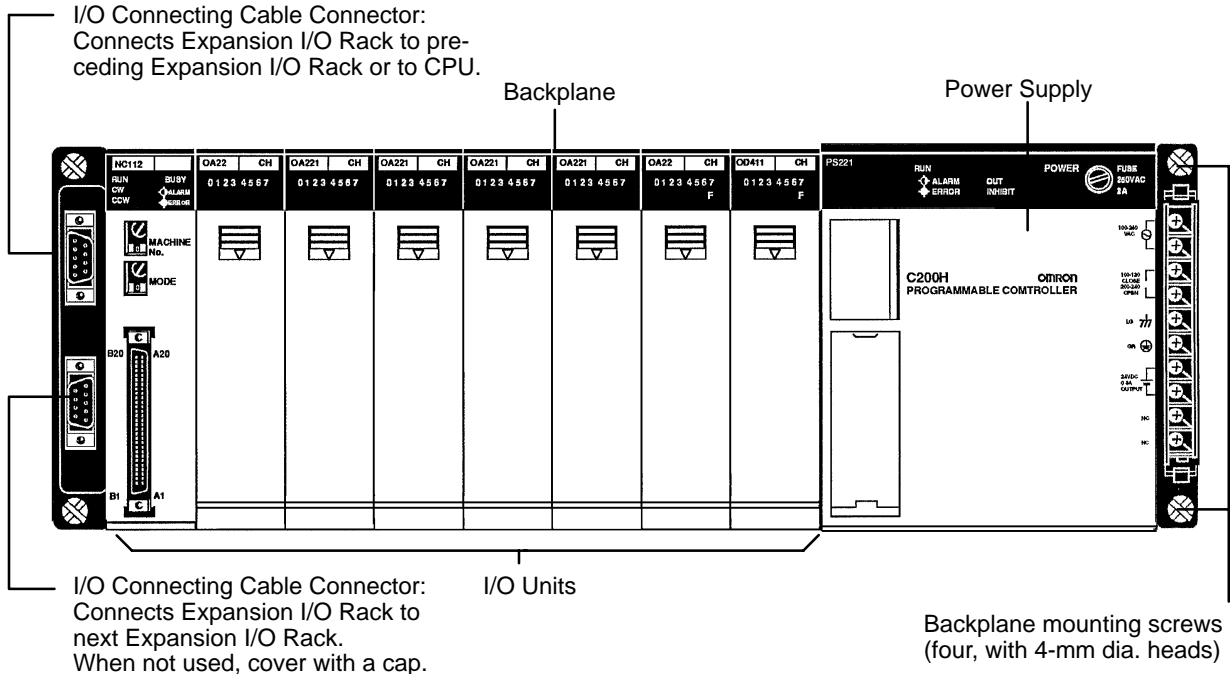

2-4 Power Supply Unit

The Power Supply used for Expansion I/O Racks is available in three models. Two run on 100 to 120 or 200 to 240 VAC, and the other runs on 24 VDC. Also, one of the AC Power Supply Units conforms to EC directives. Be very careful not to provide an AC power supply to a DC-type Unit.

AC Power Supply Unit: C200H-PS221

POWER indicator (green):
Lights when power is supplied to Power Supply

Power fuse:
2 A, 250 V
(5.2-dia. x 20) MF51NR

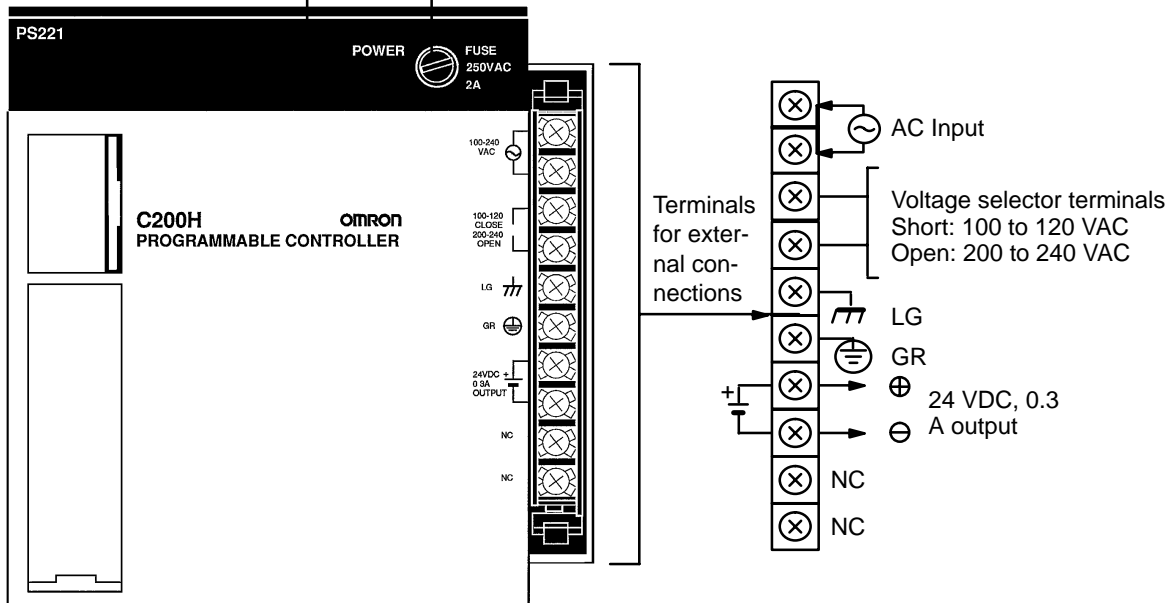

C200H-PS221-C
Conforms to EC directives.

POWER indicator (green):
Lights when power is
supplied to Power Supply

Power fuse:
2 A, 250 V
(5.2-dia. x 20) MF51NR

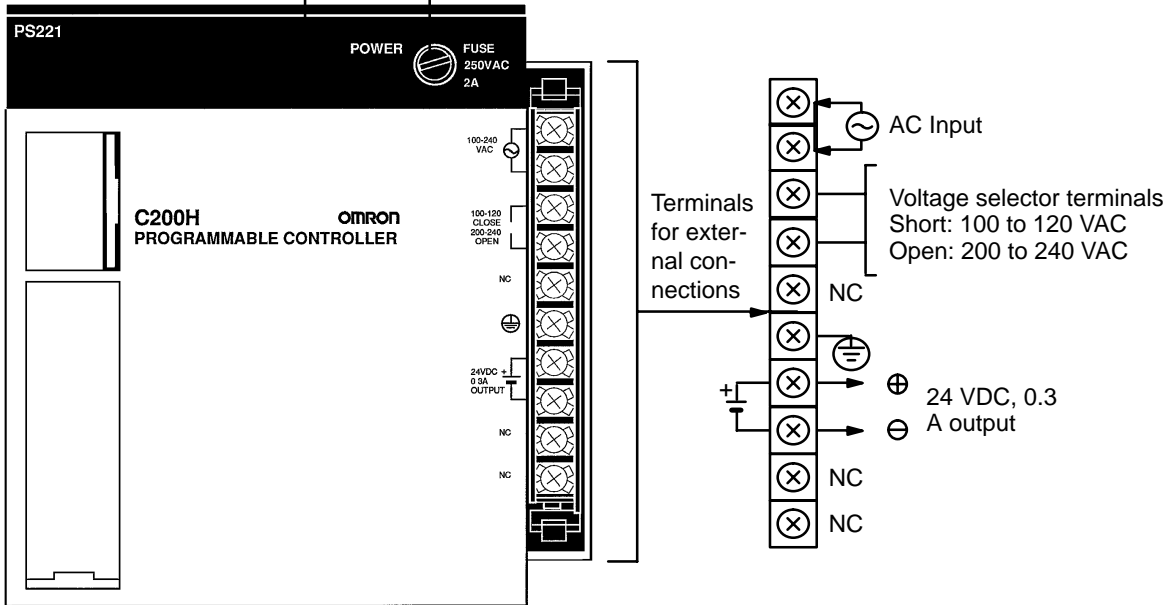

DC Power Supply Unit

C200H-PS211

Units with lot numbers □□Z5 (Dec. 1995) or later conform to EC directives.

POWER indicator (green):
Lights when power is
supplied to Power Supply

Power fuse:
5 A, 125 V
(5.2-dia. x 20) MF51NR

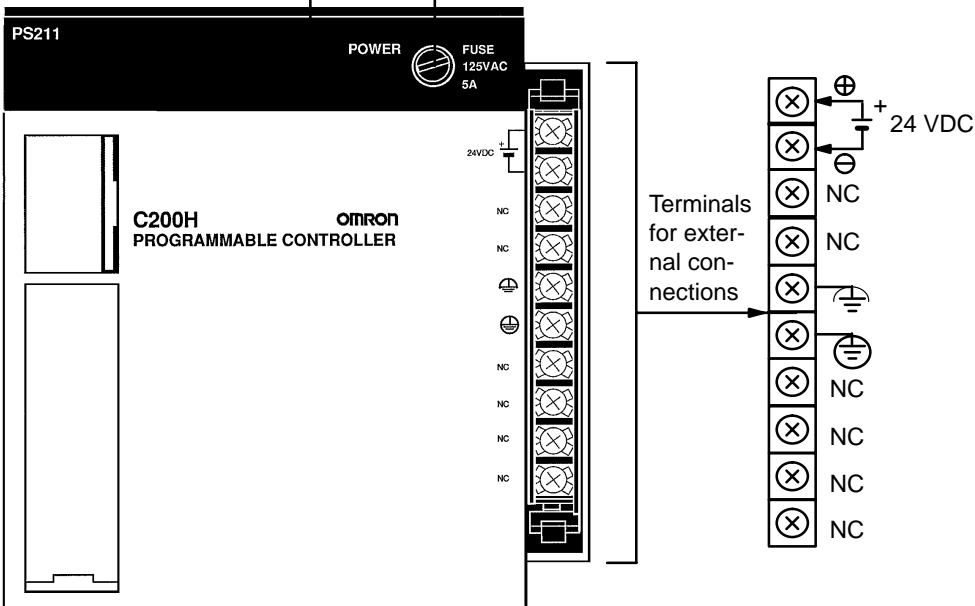

2-5 I/O Units

I/O Units are divided into three groups based on the way that I/O words they use are allocated. Standard I/O Units are allocated I/O words according to the Unit's

location on the CPU or Expansion I/O Rack. Group-2 High-density I/O Units are allocated I/O words according to I/O number set on each Unit. High-density I/O Units classified as Special I/O Unit are allocated I/O words according to the unit number set on each Unit.

2-5-1 Standard I/O Units

Standard I/O Units come in three shapes; A-shape, B-shape, and E-shape. Refer to *Appendix B Specifications* for the dimensions of each Unit.

A-shape I/O Unit (10-terminal Terminal Block)

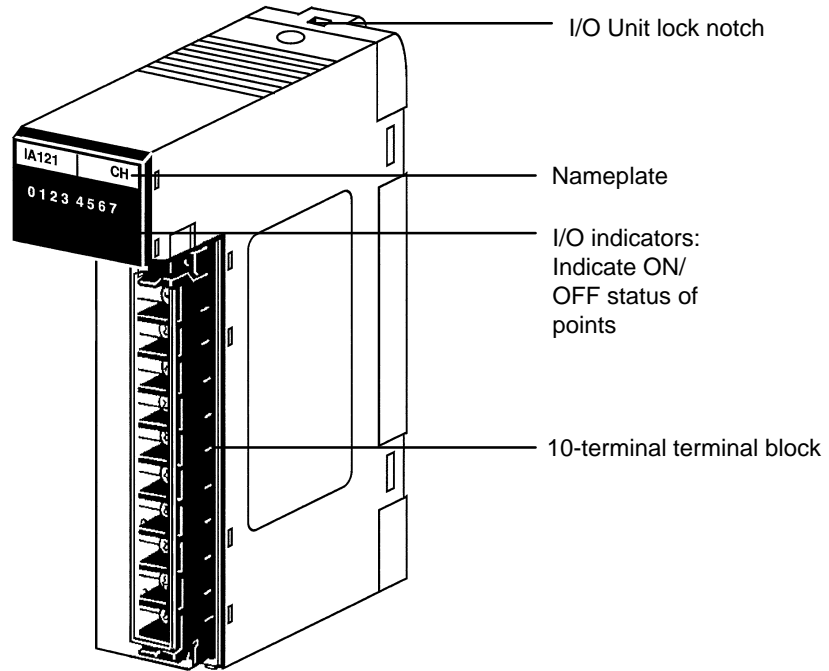

B-shape I/O Unit (19-terminal Terminal Block)

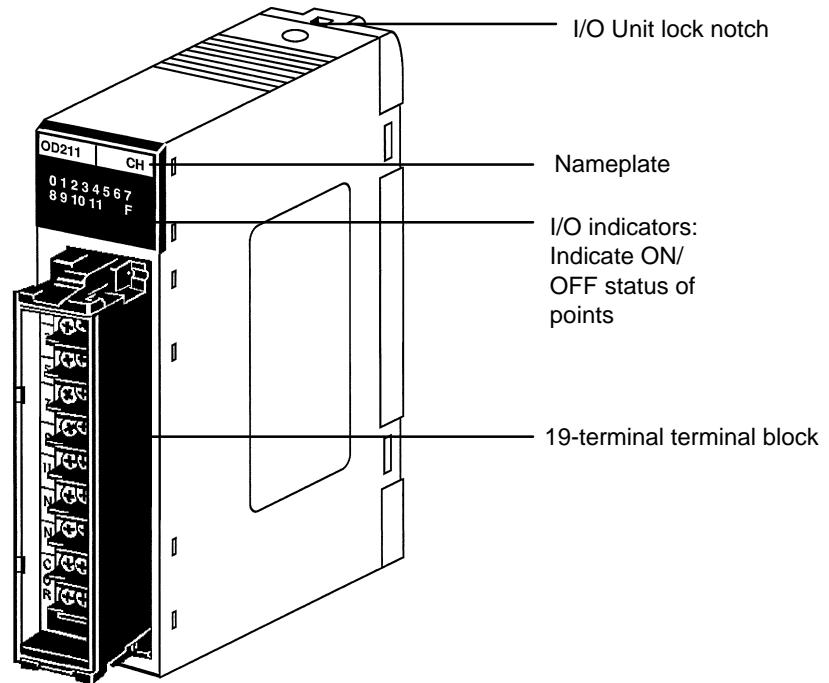

Note The C200H-OC226 is an extended B-shape I/O Unit and its dimensions are different from those of the Unit shown above.

E-shape I/O Unit (10-terminal Terminal Block)



2-5-2 Group-2 High-density I/O Units

Group-2 High-density I/O Units come in two varieties; C-shape and D-shape. The shape of the two varieties is the same, but C-shape Units have only one connector, while the D-shape Units have two. C-shape Units have 32 I/O points and D-shape Units have 64 I/O points.

Unit	Specifications	Shape	Model
DC Input Unit	12 VDC; 64 pts	D	C200H-ID111
	24 VDC; 32 pts	C	C200H-ID216
	24 VDC; 64 pts	D	C200H-ID217
			C200H-ID219
Transistor Output Unit	4.5 VDC, 16 mA to 26.4 VDC, 100 mA; 32 pts	C	C200H-OD218
		D	C200H-OD219
	4.5 VDC, 16 mA to 26.4 VDC, 100 mA; 64 pts		C200H-OD21B

Note Refer to *Optional Products, Appendix A Standard Models* for a list of external connectors.

Group-2 High-density I/O Units are allocated I/O words in the IR Area (IR 030 to IR 049) by setting the I/O number switch on the front of each Unit. C-shape Units are allocated 2 words and D-shape Units are allocated 4 words beginning with m, where $m = IR\ 030 + 2 \times I/O\ number$.

For C-shape Units the 16 I/O bits in m are allocated to the A side of the connector, and the I/O bits in m+1 are allocated to the B side of the connector. For D-shape Units the I/O bits in m are allocated to the A side of connector 1, the I/O bits in m+1 are allocated to the B side of connector 1, the I/O bits in m+2 are allocated to the A side of connector 2, the I/O bits in m+3 are allocated to the B side of connector 2. Refer to the *C200HS Operation Manual (W235)* for more details on I/O word allocation.

Always turn the PC power off before changing a Unit's I/O number. The new I/O number will not be recognized unless the PC has been turned off. Do not set more than one Unit to the same I/O number or set I/O numbers so that the same I/O word is allocated to more than one Unit, e.g., if you set a 64-point Unit to I/O number 0, you cannot use I/O number 1 for any Unit.

Refer to *Appendix B Specifications* for the specifications and dimensions of the Units.

C-shape Units (32-point Units)

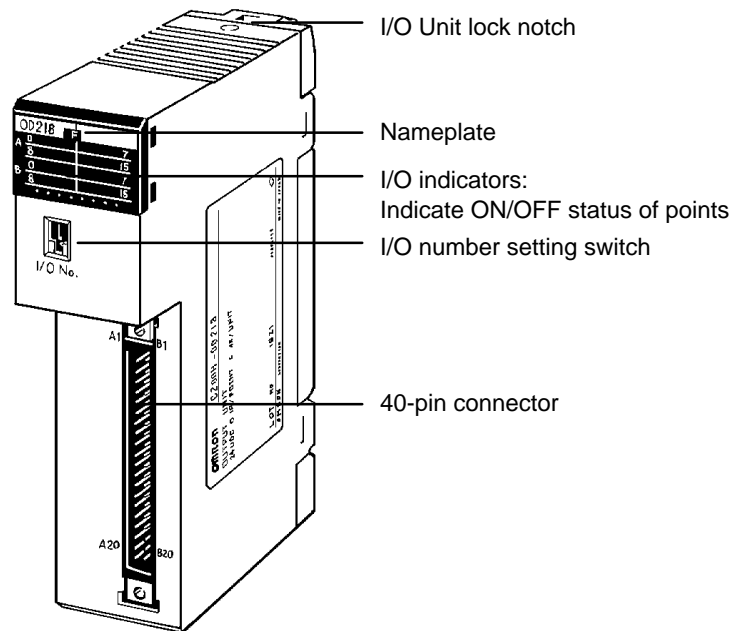

D-shape Units (64-point Units)

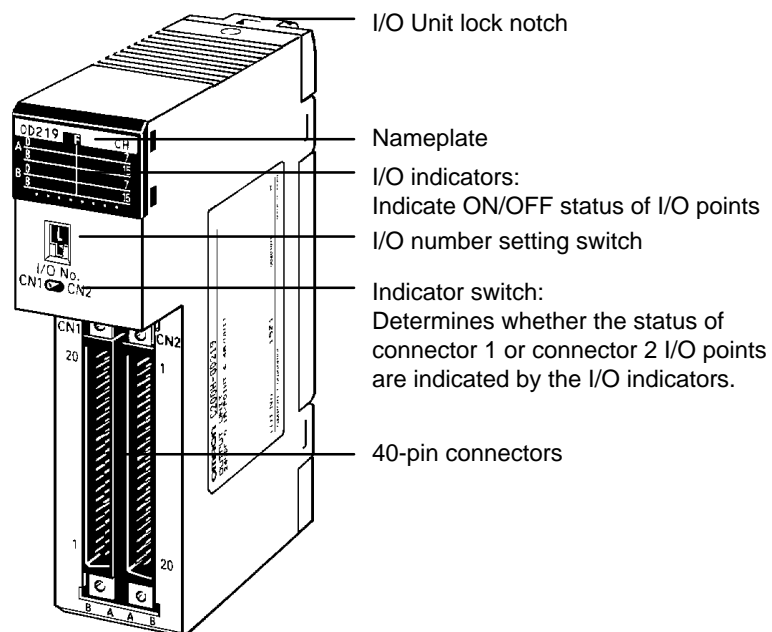

2-5-3 High-density I/O Units Classified as Special I/O Units

Some High-density I/O Units are classified as Special I/O Units. Up to 10 Special I/O Units can be connected to a PC. The Units have two 24-pin connectors. In general, these Units control 32 I/O points, although some Units can control 128 I/O points when set for dynamic operation.

Refer to *Appendix B Specifications* for detailed specifications and dimensions of the Units.

Unit	Specifications	Model Number	Remarks
TTL Input Unit	5 VDC, 32 inputs	C200H-ID501	8 pts can be set as high-speed inputs.
DC Input Unit	24 VDC; 32 inputs	C200H-ID215	
TTL Output Unit	5 VDC, 32 outputs	C200H-OD501	Can be set for 128 dynamic outputs.
Transistor Output Unit	24 VDC; 32 outputs	C200H-OD215	
TTL I/O Unit	5 VDC, 16 inputs, 16 outputs	C200H-MD501	8 pts can be set as high-speed inputs.
DC Input/Transistor Output Unit	12 VDC; 16 inputs, 16 outputs	C200H-MD115	Can be set for 128 dynamic inputs.
	24 VDC; 16 inputs, 16 outputs	C200H-MD215	

Note Refer to *Optional Products, Appendix A Standard Models* for a list of external connectors.

Setting the Unit Number

High-density I/O Units are each allocated 10 I/O words in the IR Area (IR 100 to IR 199) by setting the unit number switch on the front of each Unit. The 10 words begin with n, where $n = IR\ 100 + 10 \times \text{unit number}$. For example, a Special I/O Unit with a unit number of 3 would be allocated IR 130 to IR 139.

Always turn the PC power off before changing a Unit's unit number. The new unit number (0 to 9) will not be recognized unless the PC has been turned off.

Setting the DIP Switch

The operation of High-density I/O Units is controlled by setting the pins of the DIP switch on the back panel. The following table shows the function of each pin and applicable Units.

Pin	Function	Applicable Units	Setting	
			ON	OFF
1	Operating mode	C200H-OD501/OD215	128 dynamic outputs	32 outputs
		C200H-MD501/MD115/MD215	128 dynamic inputs	16 inputs, 16 outputs
2	High-speed input ¹	C200H-ID501/ID215	Inputs 08 to 15 of CN2 are high-speed inputs.	Normal inputs
		C200H-MD501/MD115/MD215	Inputs 08 to 15 of CN2 are high-speed inputs.	Normal inputs
3	High-speed input minimum pulse width ²	C200H-ID501/ID215 C200H-MD501/MD115/MD215	4 ms	1 ms
4	Input response time ³	C200H-ID501/ID215 C200H-MD501/MD115/MD215	15 ms max.	2.5 ms max.
5	Data output mode ⁴	C200H-OD501/OD215	Positive logic	Negative logic
6	Not used.	---	---	---

- Note**
- Used in the C200H-MD501/MD115/MD215 only when pin 1 is OFF, setting the Unit to static mode.
 - Used in the C200H-ID501/215, C200H-MD501/MD215/MD115/MD215 only when pin 2 is ON, setting the Unit to High-speed input mode.
 - Sets the input response time for normal inputs. When pin 2 is ON, CN2 08 to 15 are pulse-catch inputs. Other inputs can be used as normal inputs.

- 4. Used when pin 1 is ON, setting the C200H-OD501/OD215 to dynamic output mode.

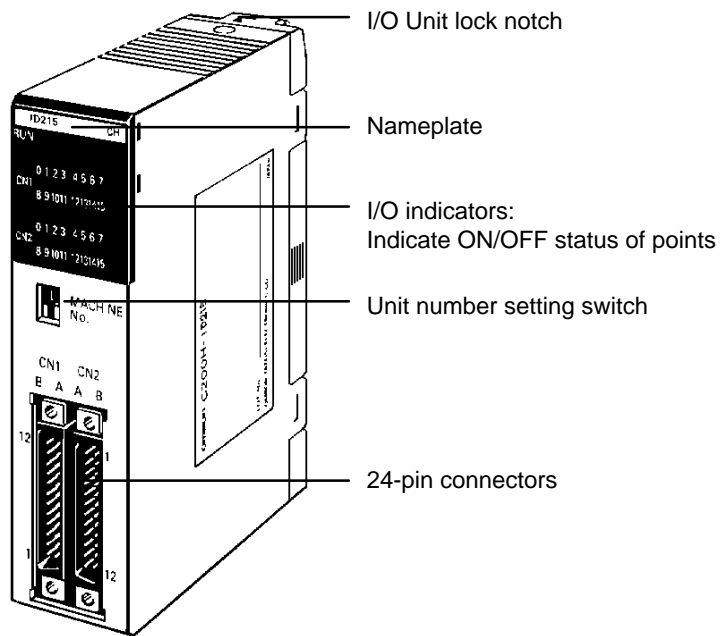

SECTION 3

Installation

The term “PC” can refer to a single object, but actually even the simplest PCs are usually composed of several different devices. In fact a PC can be physically spread throughout a building and still be called a single PC. This section describes how to install a PC System, including mounting the various Units and configuring the System. Be sure to follow the instructions carefully during installing. Improper installation can cause the PC to malfunction, resulting in extreme danger.

3-1	Installation Environment	34
3-2	Mounting Units to the Backplane	35
3-3	Installing Racks	39
3-4	I/O Connecting Cable	40
3-5	Mounting Requirements	41
3-6	Installing Memory Cassettes	43

3-1 Installation Environment

This section details the necessary environmental conditions for installing the PC.

-  **Caution** Static electricity can damage PC components. Your body can carry an electrostatic charge, especially when the humidity is low. Before touching the PC, be sure to first touch a grounded metallic object, such as a metal water pipe, in order to discharge any static build-up.

Ambient Conditions

Do not install the PC in any of the following locations. Doing so will affect PC life and may affect operating performance.

- Locations subject to ambient temperatures lower than 0°C or higher than 55°C, or 0°C to 45°C when a Programming Console is used.
- Locations subject to drastic temperature changes or condensation.
- Locations subject to ambient humidity lower than 10% or higher than 90%.
- Locations subject to corrosive or flammable gases.
- Locations subject to excessive dust (especially iron dust) or chloride.
- Locations that would subject the CPU to direct shock or vibration.
- Locations that would subject the PC to water, oil, or chemical reagents.
- Locations exposed to direct sunlight.

Cooling

There are two points to consider in order to ensure that the PC does not overheat. The first is the clearance between the Racks, and the second is installation of a cooling fan.

Clearance between Racks

The Racks need to have sufficient room between each other to allow for I/O wiring, and additional room to ensure that the I/O wiring does not hamper cooling. The Racks must also be mounted so that the total length of the Connecting Cable between all Racks in a given series does not exceed 12 m. As a general rule, about 70 to 120 mm should be left between any two Racks. Consider factors such as the width of the wiring duct, wiring length, ventilation, and ease of access to Units, when determining the spacing between Racks. Greater space is required between Racks when using certain CPU Bus and Special I/O Units. Refer to the operation manuals for the Units you are using for details.

Cooling Fan

A cooling fan is not always necessary, but may be needed in some installations. Try to avoid mounting the PC in a warm area or over a source of heat. A cooling fan is needed if the ambient temperature may become higher than that specified. If the PC is mounted in an enclosure, install a cooling fan, as shown in the following diagram, to maintain the ambient temperature within specifications.

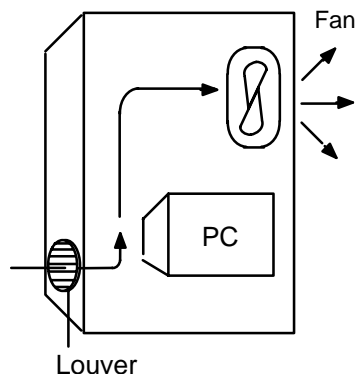

Noise

Do not mount the PC in a control panel in which high-power equipment is installed, or near high heat-producing devices such as heaters, transformers, or large-capacity resistors. To avoid noise, make sure the point of installation is at least 200 mm away from power lines as shown in the following diagram. Ensure that the plate to which the PC is mounted is grounded.



3-2 Mounting Units to the Backplane

There is no single Unit that can be said to constitute a Rack PC. To build a Rack PC, we start with a Backplane. The C200H Backplane (used for the C200HS PC) is shown below.

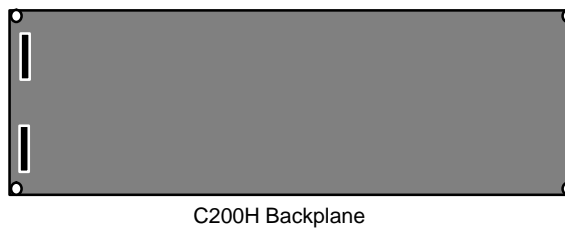

The Backplane is a simple device having two functions. The first is to provide physical support for the Units to be mounted to it. The second is to provide the connectors and electrical pathways necessary for connecting the Units mounted to it.

The core of the PC is the CPU. The CPU contains the program consisting of the series of steps necessary for the control task. The CPU has a built-in power supply, and fits into the rightmost position of the Backplane.



The CPU of the C200HS has no I/O points built in. So, in order to complete the PC it is necessary to mount one or more I/O Units to the Backplane. Mount the I/O Unit to the Backplane by locking the top of the I/O Unit into the slot on the Backplane and rotating the I/O Unit downwards as shown in the following diagram.

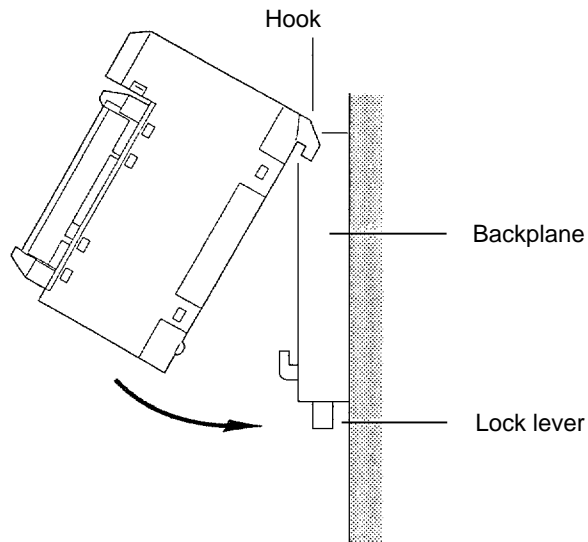

Press down on the yellow lock lever at the bottom of the slot, press the I/O Unit firmly into position, and then release the yellow lock lever.

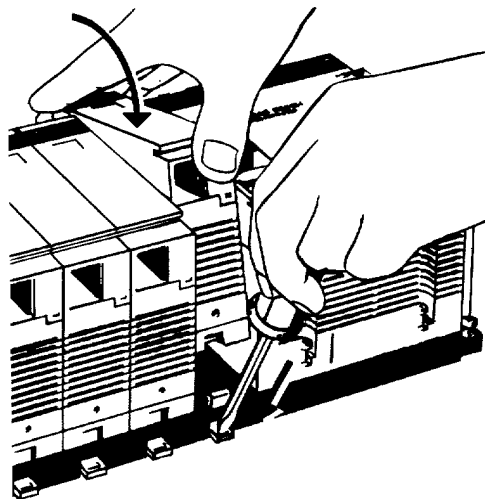

(To remove a Unit, hold down the lock lever with an implement such as a screwdriver.)

CPUs, I/O Power Supply Units and Slave Units must have two screws on the bottom tightened with a Phillips screwdriver. The screwdriver must be held at a slight angle, so be sure to leave enough space below each Rack.

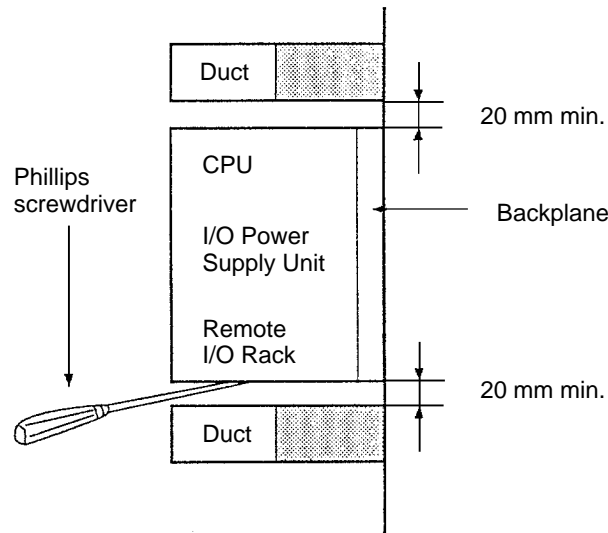

The mounting height of CPU Racks, Expansion I/O Racks, or Slave Racks is 118 mm or 143 mm depending on the type of I/O Units mounted. If Peripheral Devices or connection cables are attached, the additional dimensions must be taken into account. Allow sufficient clearance in the control panel in which the PC is mounted.

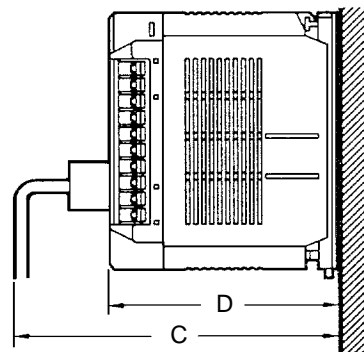

CPU	D (mm)	C (mm)
C200HS-CPU01-E/CPU01-EC /CPU03-E	118	Approx. 180 to 200
C200HS-CPU21-E/CPU21-EC /CPU23-E/CPU31-E/CPU33-E	143	Approx. 200 to 220

The figure below shows one I/O Unit mounted directly to the left of the CPU.



I/O Units are where the control connections are made from the PC to all the various input devices and output devices. As you can see from the figure above,

there is still some space available on the left side of the Backplane. This space is for any additional I/O Units that may be required.



The figure above shows a total of eight I/O Units mounted to the Backplane. When using 16-point Output Units (models C200H-OC225/OD212/OD21A) mount them to a C200H-BC□□1-V1/V2 Backplane. If a Backplane other than this model is used, the Units will not operate properly.

Interrupt Input Units must be mounted to a C200H-BC□□1-V2 Backplane to operate properly. Only one Interrupt Input Unit can be mounted per PC.

Backplanes are available in different lengths (three, five, eight, ten slots), and can hold a different number of I/O Units accordingly (refer to *Appendix B Specifications* for dimensions). Of course, not all I/O Units look exactly alike, but the ones in the figure show their typical appearance. This configuration of Backplane, CPU, and I/O Units is called a CPU Rack. This term refers to the Backplane and all the Units mounted to it. However, if we want to include more than eight I/O Units in our configuration we can add an additional Backplane.

This Backplane has I/O Units mounted to it, but it has no CPU of its own. The additional Backplane must also have an Expansion I/O Power Supply mounted to its rightmost position. This configuration of additional Backplane, Expansion I/O Power Supply, and I/O Units is called an Expansion I/O Rack.

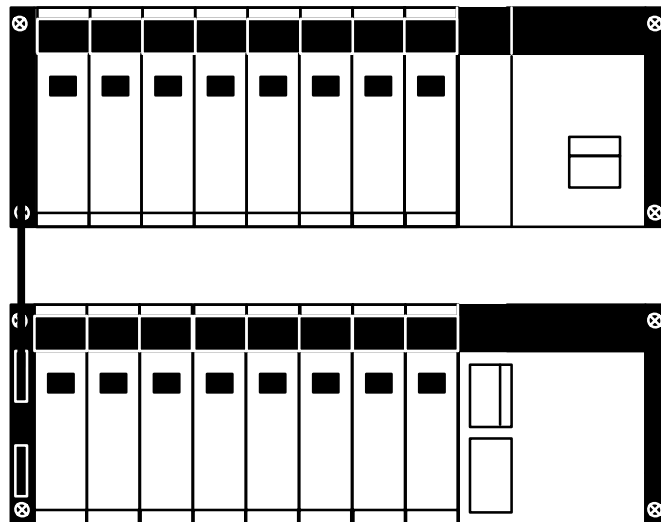

The CPU Rack and Expansion I/O Rack shown above are connected by a Connecting Cable (the length of Cable between individual Racks can be up to 10 m, but the total length of Cable between all Racks must be within 12 m).

Remember that this whole configuration is still referred to as one PC. It is possible to add up to two Expansion I/O Racks and five Remote I/O Slave Racks to one CPU Rack. When installing I/O Connecting Cables, cover any unused connectors with the caps provided.

3-3 Installing Racks

The following figures show two side views, each consisting of a mounted CPU and two Expansion I/O Racks. Provide a space of 20 mm minimum on the upper and lower sides of each duct for ventilation and Unit replacement purposes.

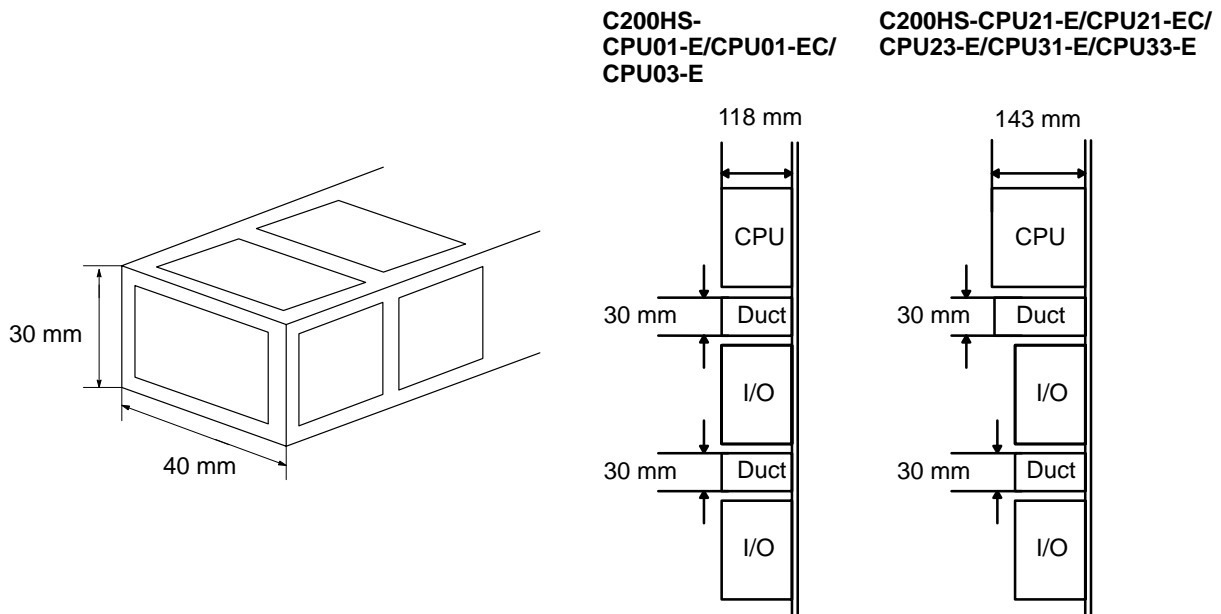

Each Rack must be mounted vertically, that is, with the printing on the front panels oriented as it would normally read. Racks may be directly mounted to any sturdy support meeting the environmental specifications. Whenever possible, use wiring conduit to hold the I/O wiring. Standard wiring conduit should be used, and it should be long enough to completely contain the I/O wiring and keep it separated from other cables.

⚠ Caution Racks must be mounted horizontally so that the Units are upright (i.e., not upside down or lying on their backs).

The duct work shown in the following diagram is not used for mounting the Racks. Although optional, this duct work can be used to house the wires from the I/O Units that run along the sides of the Racks, keeping the wires from becoming entangled. This figure illustrates the correct way to mount the Racks.



3-4 I/O Connecting Cable

Up to 10 meters of I/O connecting cable can be used in one place only, and the maximum total length of connecting cable that can be used is 12 meters. Do not place I/O connecting cable in the same ducts used for I/O lines and power lines. Insert the cable firmly in the CPU Rack and Expansion I/O Rack connectors, and be sure to secure it by firmly tightening the two screws.

Caution If an I/O connecting cable connector comes loose, an I/O bus error will be generated and operation will stop.

If I/O connecting cable is to be passed through a hole, a diameter of at least 53 mm is required. If the upper cover is removed, it can be passed through a hole with a diameter of 33 mm or larger. Then, at the time of installation, put it back together and be sure to fasten the screws.

The tensile strength of the cable is 4.9 N (5 kgf). Do not subject the cable to a force greater than that.

3-5 Mounting Requirements

Each Rack must be mounted vertically, that is with the printing on the front panels oriented as it would normally be read. The Racks should be mounted one above the other with the CPU Rack uppermost as shown below.

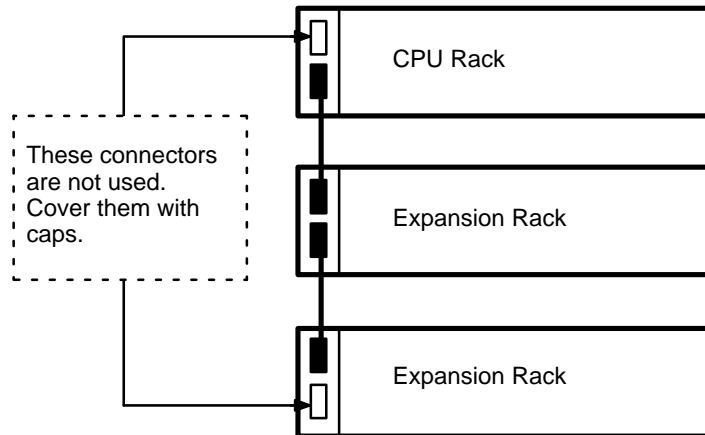

The C200HS is approved by Underwriters Laboratories under the condition that, "The device must be mounted vertically for ventilation purposes."

DIN Track Mounting

The PC may be mounted using DIN track if desired. This type of mounting is not required, and the PC may be directly mounted to any sturdy support meeting the environmental specifications (refer to *Appendix B Specifications*). If you want to mount the PC on DIN track, you can order a DIN Track from OMRON (refer to *Appendix B Standard Models*). DIN Tracks come in the two heights shown below.

7.3-mm Height

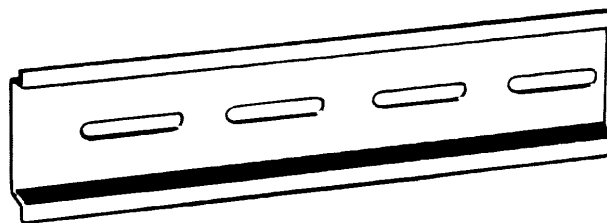

16-mm Height

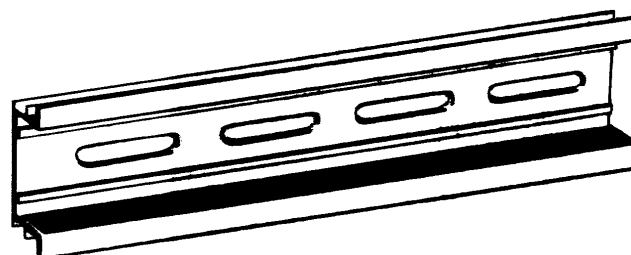

DIN Track Mounting Bracket The DIN Track Mounting Bracket shown below is necessary for mounting the PC to the DIN Track.



Item	Specification	Model
DIN Track Mounting Bracket	One set (two brackets)	C200H-DIN01
DIN	50 cm long, 7.3 mm high	PFP-50N
	1 m long, 7.3 mm high	PFP-100N
	1 m long, 16 mm high	PFP-100N2

Procedure

- 1, 2, 3...** 1. The following diagram is a view of the back of the Backplane. Attach one Mounting Bracket to the left and right sides of the Backplane as shown below.

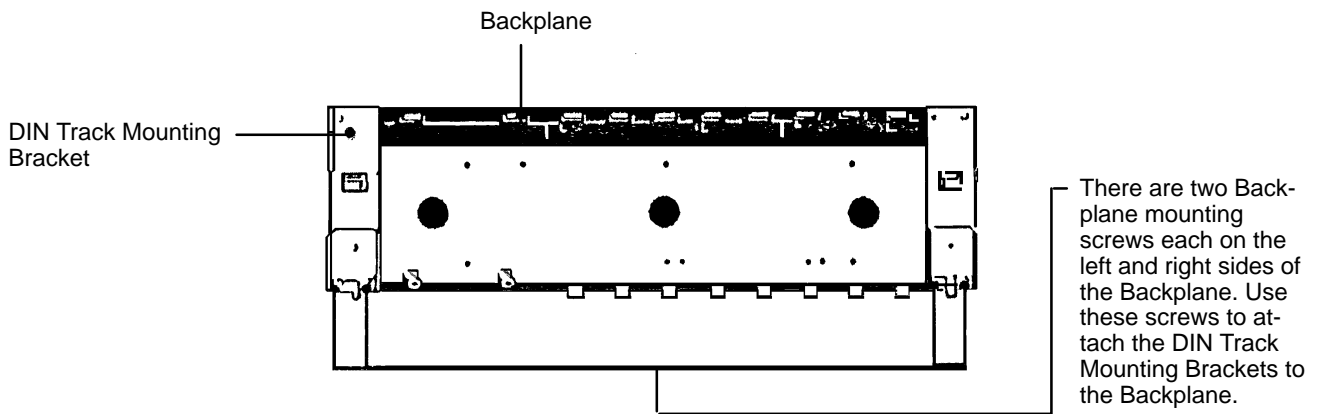

2. Mount the Backplane to the DIN Track so that the claws on the Mounting Brackets fit into the upper portion of the DIN Track as shown below.

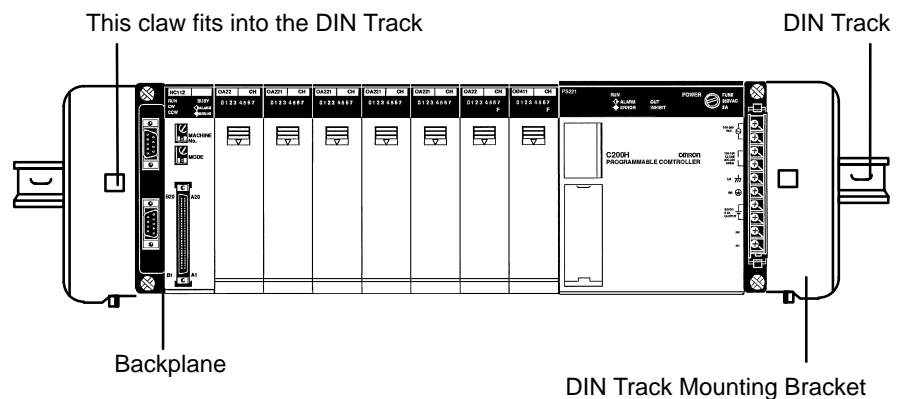

- Loosen the screws attaching the Mounting Brackets to the Backplane. Slide the Backplane upward as shown below so that the Mounting Bracket and Backplane clamp securely onto the DIN Track. Tighten the screws.

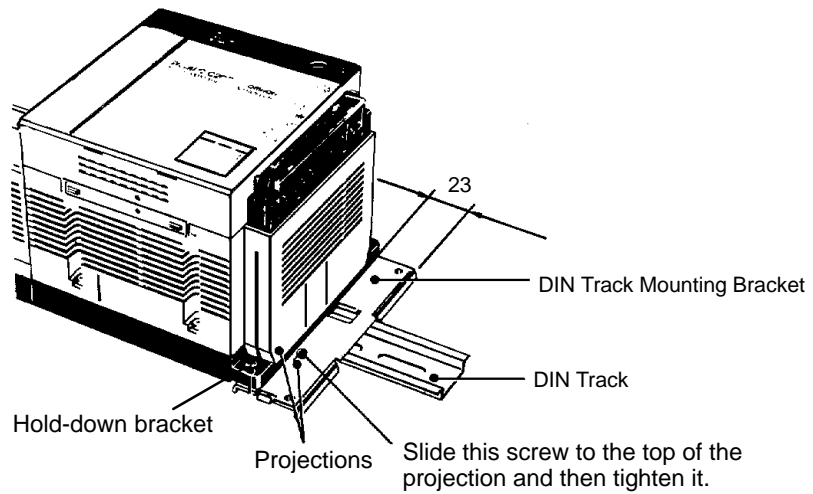

3-6 Installing Memory Cassettes

An optional Memory Cassette can be installed in the C200HS. (The C200H Memory Unit cannot be used with the C200HS.) The two types of Memory Cassettes are described in 2-2-6 *Memory Cassettes*. To install a Memory Cassette, follow the procedure outlined below.

! Caution Be careful to always turn the power off before inserting or removing a Memory Cassette. If a Memory Cassette is inserted into or removed from the CPU with the power on, it may cause the CPU to malfunction or cause damage to the memory.

- 1, 2, 3... 1. Set the DIP switch. For an EEPROM Memory Cassette, set pin no. 1 (write protect) to either ON or OFF. Setting it to ON will protect the program in the memory from being overwritten. Setting it to OFF will allow the program to be overwritten. (The factory setting is OFF.)

For an EPROM Memory Cassette, set pin no. 1 (ROM Type Selector) according to the type of ROM that is to be mounted. Even if a 27512-type chip is mounted, the usable capacity is still only 16 KB.

Pin no. 1	ROM type	Model	Capacity	Access speed
OFF	27256	ROM-JD-B	16 KB	150 ns
ON	27512	ROM-KD-B	32 KB	150 ns

2. Write to EPROM (if using an EPROM Memory Cassette). Using a PROM Writer, write the program to EPROM. Then mount the EPROM chip to the Memory Cassette, with the notched end facing upwards as shown in the illustration below.

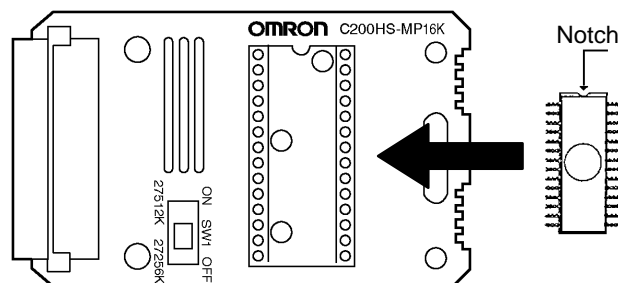

3. Remove the bracket from the Memory Cassette, as shown in the illustration below.

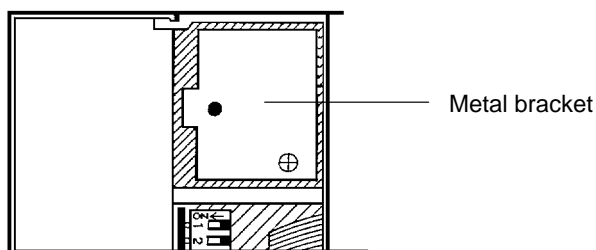

4. Check that the connector side goes in first and that the Cassette's circuit components face right and then insert the Cassette into the CPU. The Cassette slides in along a track in the CPU.

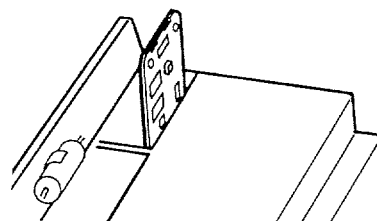

5. Replace the Memory Cassette bracket over the Cassette and tighten the screw that holds the bracket.

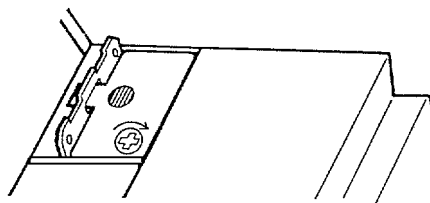

SECTION 4

Wiring

This section provides the information necessary to wire a C200HS System.

4-1	Power Supply Wiring	46
4-2	AC Power Supply	46
4-3	DC Power Supply	47
4-4	RUN Output Terminals	48
4-5	Grounding	48
4-6	Backplane Insulation Plate	49
4-7	Standard I/O Unit Wiring	50
4-8	Input Circuits	53
4-9	Output Circuits	54
4-10	External Wiring	57
4-11	System Design and Safety Considerations	57
4-11-1	Power Supply System and Emergency Stop Circuit	57
4-11-2	Interlock Circuit	58
4-11-3	Programmable Controller Power Interruptions	59

4-1 Power Supply Wiring

Pay attention to the following points when wiring the power supply.

- Be sure to mount the CPU and the I/O Power Supply Unit in their proper positions.
- Provide power to the CPU and the I/O Power Supply Unit from the same power source. If different power sources are provided, then the CPU and the Programming Console will not operate whenever power is not turned on to the I/O Power Supply Unit.
- When a DC power supply is used, be sure to properly connect the plus and minus terminals.
- Securely lock removeable terminal blocks.
- Wire the Units with the top-surface labels still in place, and then remove the labels after the wiring is completed.

4-2 AC Power Supply

The C200HS-CPU01-E, C200HS-CPU01-EC, C200HS-CPU21-E, C200HS-CPU21-EC and C200HS-CPU31-E CPUs, and the C200H-PS221 and C200H-PS221-C I/O Power Supply Units use an AC power supply. Provide either 100 to 120 VAC or 200 to 240 VAC, with an allowable fluctuation range of 85 to 132 VAC or 170 to 264 VAC respectively.

C200HS-CPU01-E/CPU01-EC/CPU21-E/CPU21-EC/CPU31-E

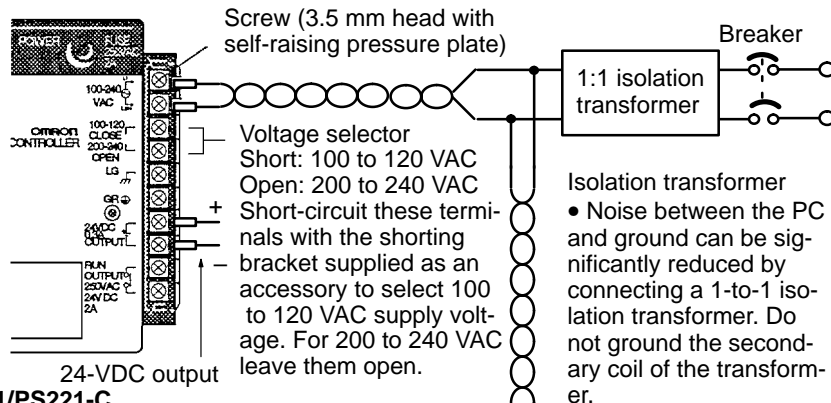

- AC power source
- Supply 100 to 120 or 200 to 240 VAC
 - Keep voltage fluctuations within the specified range (refer to *Appendix B Specifications*)

Note:
The LG markings of the C200HS-CPU□□-E and C200HS-CPU□□-EC are different from each other.

Isolation transformer

- Noise between the PC and ground can be significantly reduced by connecting a 1-to-1 isolation transformer. Do not ground the secondary coil of the transformer.

C200H-PS221/PS221-C

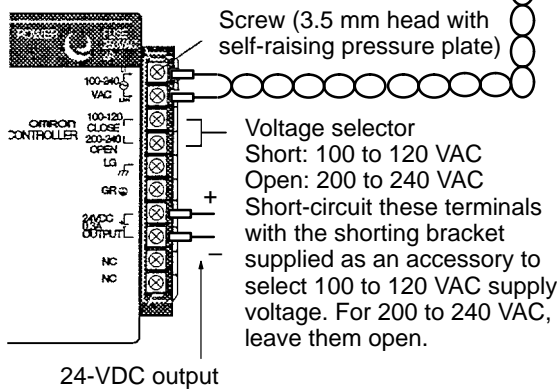

Power line

- Use AWG 14 twisted pair cable (cross-sectional area of 2 mm² min).

Note:
The LG markings of the C200HS-PS221 and C200HS-PS221-C are different from each other.

Note The C200HS-CPU01-EC CPU, C200HS-CPU21-EC CPU, and C200H-PS221-C I/O Power Supply Unit do not have an LG terminal.

24-VDC Output

Use these terminals as the power supply for 24-VDC Input Units.

Note DC Power Supply Units do not have these terminals.

Crimp Terminals

When wiring, use crimp terminals.

Do not connect power lines that have only been twisted together directly to the terminal blocks.

Tighten terminal block screws with a torque of 0.8 N-m.

Use crimp terminals suitable for M3.5 screws that have the following dimension.

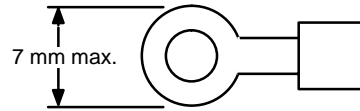

Caution Tighten power supply terminal screws with a torque of 0.8 N-m. Not tightening the screws securely may result in a fire or faulty operation.

- Note**
1. Be sure to use the same circuits when supplying power to the Power Supply Units.
 2. Check the settings for the power supply voltage switching terminals.
 3. After the wiring has been completed, be sure to remove the top-surface label in order to allow heat radiation.

4-3 DC Power Supply

The C200HS-CPU03-E, C200HS-CPU23-E, and C200HS-CPU33-E CPUs, and the C200H-PS211 I/O Power Supply Unit use a 24-VDC power supply with an allowable fluctuation range of 20.4 to 26.4 VDC.

C200H-CPU03-E/CPU23-E/CPU33-E

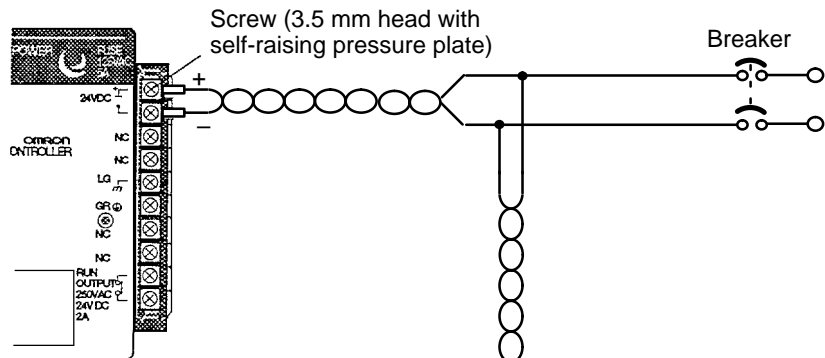

C200H-PS211

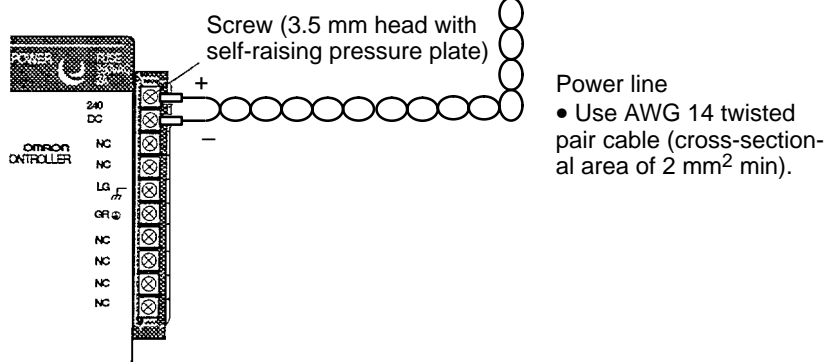

4-4 RUN Output Terminals

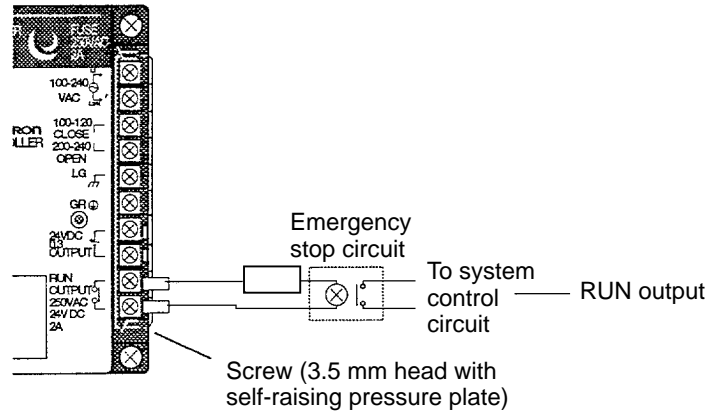

RUN Output

These terminals are short-circuited during PC operation. Use them to receive PC RUN signals, for purposes such as emergency stop circuits.

Maximum switching capacity:

250 VAC, 2 A ($\cos \phi = 1$)

250 VAC, 0.5 A ($\cos \phi = 0.4$)

24 VDC, 2 A

- Note**
1. I/O Power Supply Units do not have these terminals.
 2. For the C200H-CPU03-E, use a DC power supply provided with reinforced insulation or double insulation if the EC directives (low-voltage directives) must be satisfied.

4-5 Grounding

To avoid electrical shock, attach a grounded (earth ground) AWG 14 wire (cross-sectional area of at least 2 mm^2) to the GR terminal. The resistance to ground must be less than 100Ω . Do not use a wire longer than 20 m. Care must be taken, because ground resistance is affected by environmental conditions such as soil composition, water content, time of year, and the length of time since the wire was laid underground.

The Line Ground (LG) terminal is a noise-filtered neutral terminal that does not normally require grounding. If electrical noise is a problem, however, this terminal should be connected to the Ground (GR) terminal.

PC operation may be adversely affected if the ground wire is shared with other equipment, or if the ground wire is attached to the metal structure of a building.

When using an Expansion I/O Rack, the Rack must also be grounded to the GR terminal. The same ground can be used for all connections.

C200HS-CPU01-E/CPU01-EC/CPU03-E/CPU21-E/CPU21-EC/CPU31-E/CPU23-E/CPU33-E

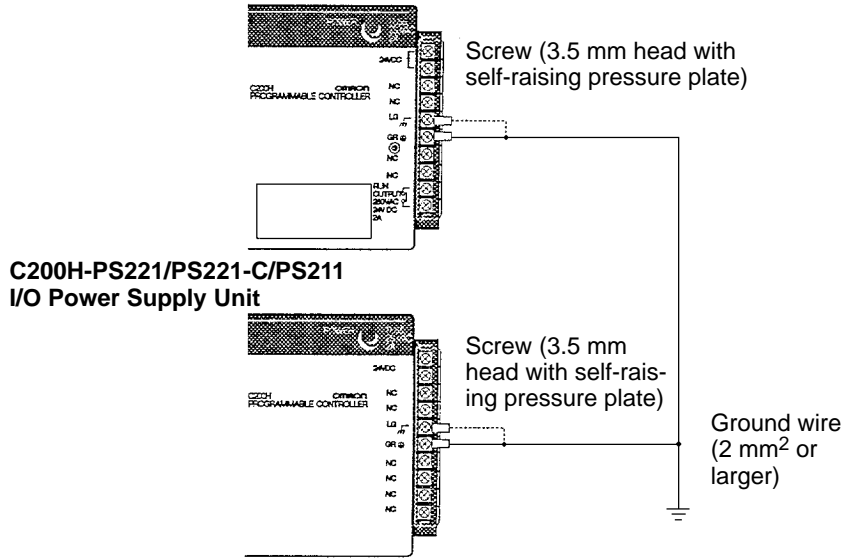

Note The LG terminal is not provided for the C200HS-CPU01-EC CPU and C200H-PS221-C I/O Power Supply Unit.

4-6 Backplane Insulation Plate

If there is an electric potential difference between grounds when devices are wired separately, then use a Backplane Insulation Plate. There are four models available, corresponding to the number of slots in the Backplane. The dimensions at locations A, B, C, D, and E are shown below in millimeters for each Backplane Insulation Plate model.

Specifications	Model	Dimensions (mm)				
		E	D	C	B	A
For 3 slots	C200H-ATT31	261	210	---	---	246
For 5 slots	C200H-ATT51	331	280	---	---	316
For 8 slots	C200H-ATT81	436	385	---	---	421
For 10 slots	C200H-ATTA1	506	455	227.5	270.5	491

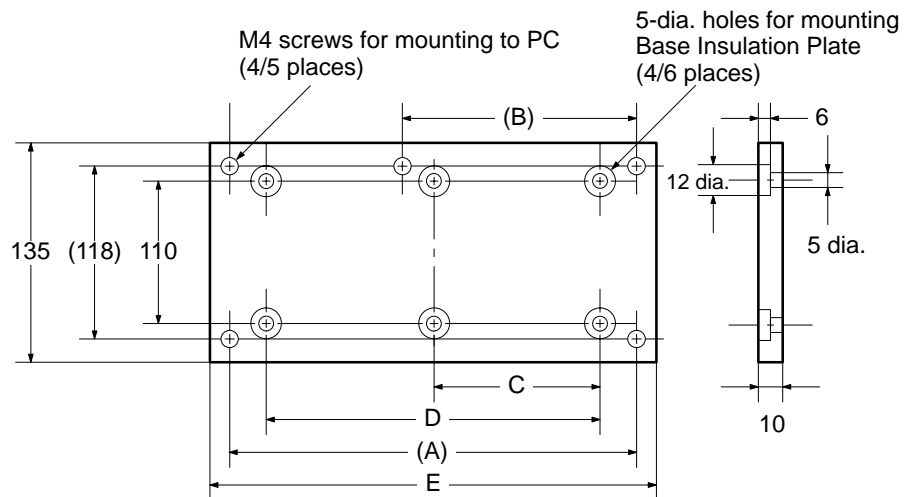

4-7 Standard I/O Unit Wiring

⚠ Caution Check the I/O specifications for the I/O Units, and consider the following points.

- For the I/O Units, use a DC power supply provided with reinforced insulation or double insulation if the EC directives (low-voltage directives) must be satisfied.
- Do not apply a voltage that exceeds the input voltage for Input Units or the maximum switching capacity for Output Units. Doing so may result in breakdown, damage or fire.
- When the power supply has positive and negative terminals, be sure to wire them correctly.

Electric Wires

The following electric wires are recommended.

Terminal Block Connector	Electric Wire Size
10-terminal	AWG 22 to 18 (0.33 to 0.82 mm ²)
19-terminal	AWG 22 (0.33 mm ²)

Larger sizes than these can be used for common lines.

Note The allowable current capacity electric wire differs depending on factors such as ambient temperature, insulation thickness, etc., so be sure to take these factors into account when selecting electric wire.

The terminals have screws with 3.5-mm diameter heads and self-raising pressure plates. Connect the lead wires to the terminals as shown below. Tighten the screws with a maximum torque of 0.8 N•m.

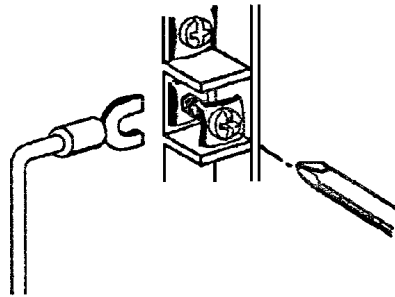

Crimp Terminals

If you wish to attach solderless type terminals to the ends of the lead wires, use terminals having the dimensions shown below.



Wiring

Be sure that each Unit is securely mounted. In order to prevent wire scraps and other objects from getting inside of the Unit, keep the top-surface label on while wiring the Unit. After the wiring has been completed, be sure to remove the label in order to allow heat radiation.

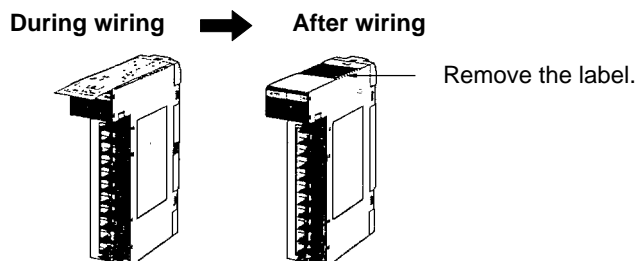

Wire the Units so that they can be easily replaced. In addition, make sure that the I/O indicators are not affected by the wiring.

Terminal Blocks

Unlock the terminal block of an I/O Unit to remove the terminal block from the I/O Unit. You do not have to remove the lead wires from the terminal block in order to remove it from an I/O Unit.

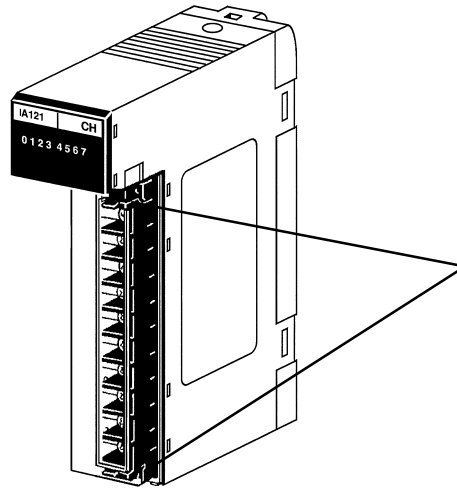

Locks for terminal block. Unlock to remove the terminal block from the I/O Unit. Make sure the terminal block is locked securely after wiring is complete.

I/O Unit Cover

A C200H-COV11 Cover is provided as an I/O Unit cover for Units that use 10P terminal block connectors. After the I/O wiring has been completed, slide the cover up from the bottom, as shown in the illustration below.

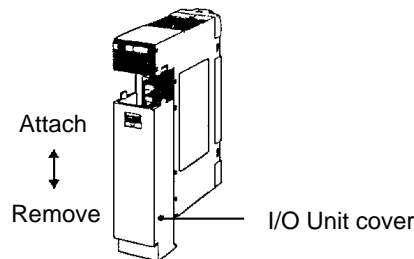

Wiring Examples

The following are examples of how to connect I/O devices to I/O Units. During wiring, work slowly and carefully. If an input device is connected to an Output Unit, damage may result. Check all I/O devices to make sure they meet the specifications (refer to *Appendix A Specifications*).

DC Input Units

Contact output

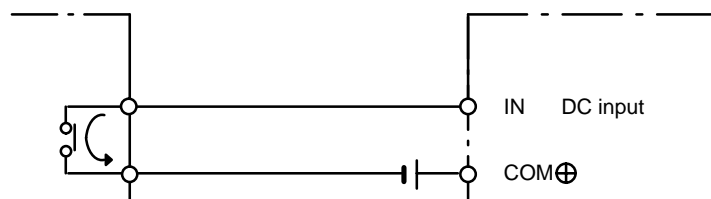

When using the NPN-current-output configuration shown below, the sensor and Input Unit should receive their power from the same supply.

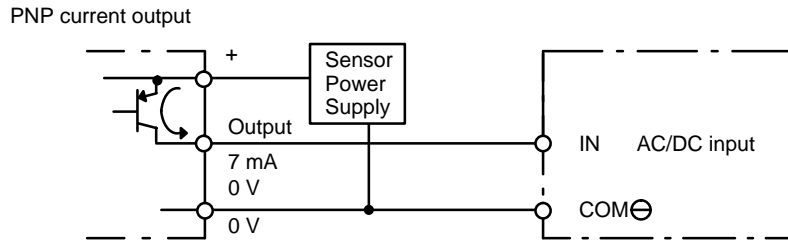
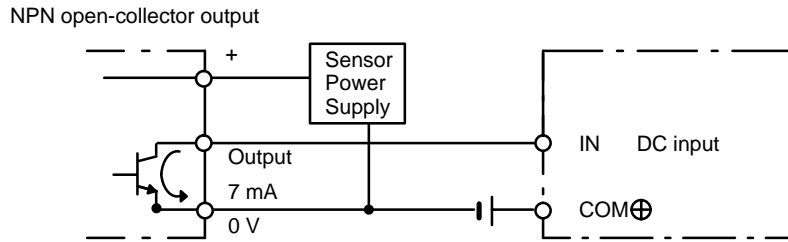
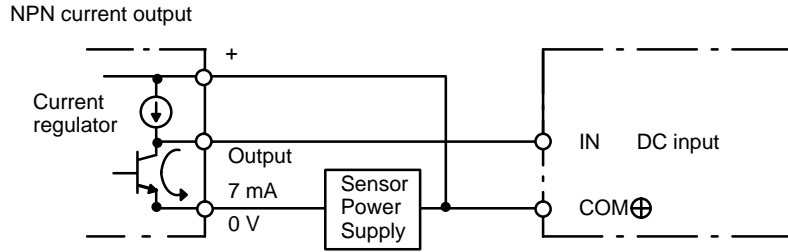

The circuit below should be used for I/O devices having a voltage output.

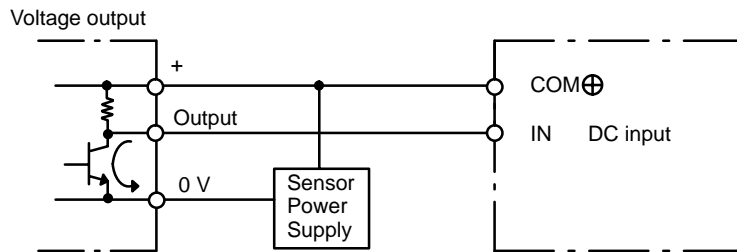

The circuit below should **NOT** be used for I/O devices having a voltage output.

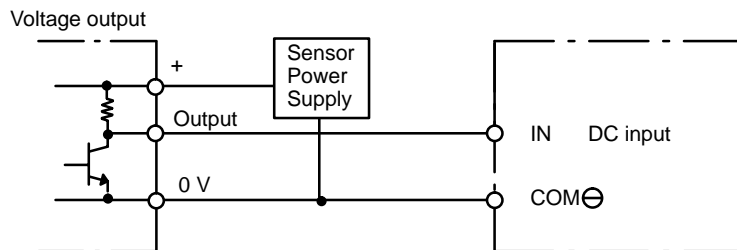

AC Input Units



4-8 Input Circuits

Input Leakage Current

When two-wire sensors, such as photoelectric sensors, proximity sensors, or limit switches with LEDs, are used for 12/24-VDC input devices, the input bit may be turned ON erroneously by leakage current. In order to prevent this, connect a bleeder resistor across the input as shown below.

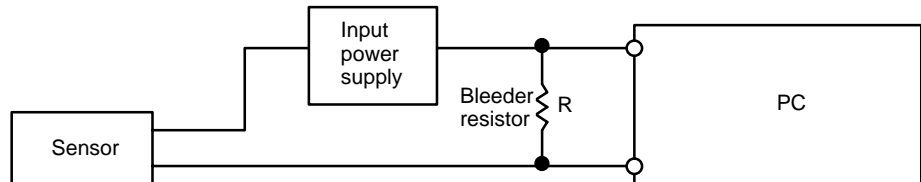

If the leakage current is less than 1.3 mA, there should be no problem. If the leakage current is greater than 1.3 mA, determine the resistance and power rating for the bleeder resistor using the following formulas.

For standard I/O Units:

$$I = \text{leakage current in mA}$$

$$R = \frac{7.2}{2.4 \times I - 3} \text{ k}\Omega \text{ max.}$$

$$W = \frac{2.3}{R} \text{ W min.}$$

Precautions for Connecting Two-wire Sensors

When two-wire sensors are used for 12/24-VDC input devices, check that the following conditions are satisfied. Failure to do so may result in faulty operation.

Relationship between ON Voltage (V_{ON}) of the PC and Residual Voltage of the Sensor (V_R)

$$V_{ON} \leq V_{CC} - V_R$$

Relationship between ON Current (I_{ON}) of the PC and Control Output (Load Current) of the Sensor (I_{OUT})

$$I_{OUT} (\text{min}) \leq I_{ON} \leq I_{OUT} (\text{max})$$

$$I_{ON} = (V_{CC} - V_R - 1.5 [\text{PC's internal residual voltage}]) / R_{IN}$$

If I_{ON} is less than $I_{OUT} (\text{min})$, connect bleeder resistance R. Obtain the constant for the bleeder resistance according to the following formula.

$$R \leq (V_{CC} - V_R) / (I_{OUT} (\text{min}) - I_{ON})$$

$$\text{Power } W \geq (V_{CC} - V_R)^2 / R \times 4 [\text{tolerance}]$$

Relationship between OFF Current (I_{OFF}) of the PC and Leakage Current of the Sensor (I_{leak})

$$I_{OFF} \cong I_{leak}$$

For details, refer to sections providing precautions on leakage current. The value of I_{OFF} will vary depending on the on the Unit. However, the value for Input Units for which OFF current specifications are not listed will be 1.3 mA.

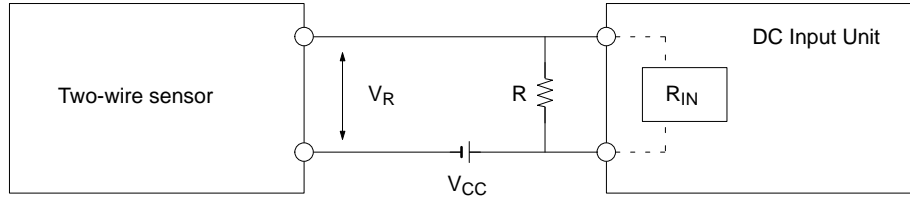

- V_{CC} : Power supply voltage
- V_{ON} : PC ON voltage
- I_{ON} : PC ON current
- I_{OFF} : PC OFF current
- R_{IN} : PC input impedance
- V_R : output residual voltage in the sensor
- I_{OUT} : control output of the sensor (load current)
- I_{leak} : leakage current of the sensor
- R: bleeder resistance

4-9 Output Circuits

When wiring outputs, take the following points into consideration.

Output Short-circuit Protection

If a load connected to the output terminals is short-circuited, output elements and printed boards may be damaged. To guard against this, incorporate a fuse in an external circuit.

Transistor Output Residual Voltage

When connecting TTL circuits to transistor Output Units, it is necessary to connect a pull-up resistor and a CMOS IC between the two. This is because of the residual voltage left on the transistor output after the output turns OFF.

Output Leakage Current

If there is a possibility of leakage current causing a transistor or triac to malfunction, connect a bleeder resistor across the output as shown below.



Determine the value and rating for the bleeder resistor using the following formula.

$$R < \frac{E_{on}}{I}$$

Where

E_{on} = ON voltage of the load in V

I = leakage current in mA

R = bleeder resistance in k Ω

Output Surge Current

When connecting a transistor or triac Output Unit to an output device having a high surge current (such as an incandescent lamp), care must be taken to avoid damage to the Output Unit. The transistor and triac Output Units are capable of withstanding a surge current of ten times the rated current. If the surge current for a particular device exceeds this amount, use the circuit shown below to protect the Output Unit.

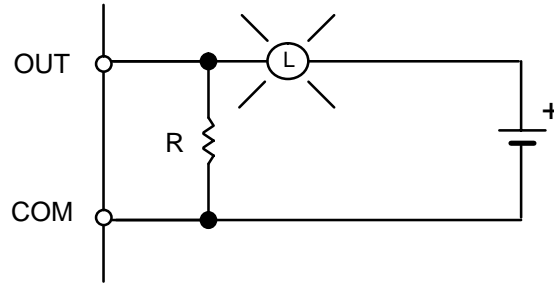

Another way of protecting the Output Unit lets the load draw a small current (about one third the rated current) while the output is OFF, significantly reducing the surge current. This circuit (shown below) not only reduces the surge current, but also reduces the voltage across the load at the same time.

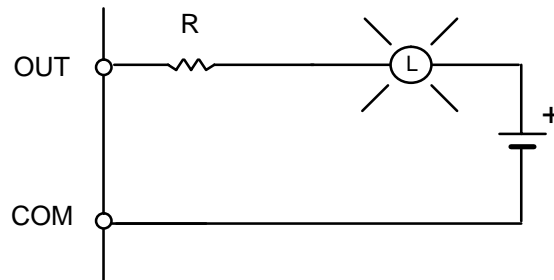
**Electrical Noise**

Whenever possible, place I/O signal lines and power lines in separate ducts or tubes. If placing them together cannot be avoided, use shielded cable to minimize the effects, and connect the shielded end to the GR terminal.

Inductive Load Surge Suppressor

When an inductive load is connected to an I/O Unit, it is necessary to connect a surge suppressor or diode in parallel with the load as shown below. This is so that the back EMF generated by the load will be absorbed.

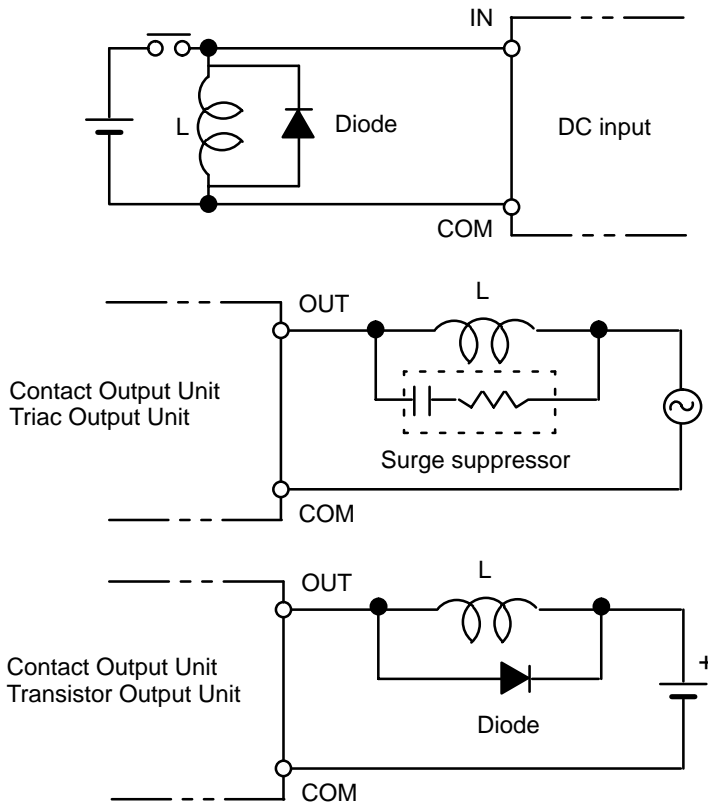

Use surge suppressors and diodes with the following specifications.

Surge Suppressor

- Resistance: 50 Ω
- Capacitor: 0.47 μF
- Voltage: 200 V

Diode

- Leading-edge peak inverse voltage: At least 3 times load voltage
- Average rectified current: 1 A

4-10 External Wiring

If power cables must be run alongside the I/O wiring (that is, in parallel with it), at least 300 mm must be left between the power cables and the I/O wiring as shown below.

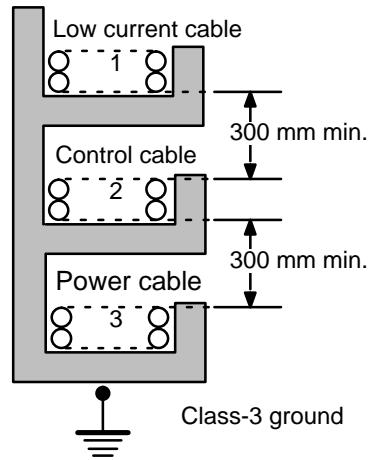

Where: 1 = I/O wiring
 2 = General control wiring
 3 = Power cables

If the I/O wiring and power cables must be placed in the same duct (for example, where they are connected to the equipment), they must be shielded from each other using grounded metal plates.

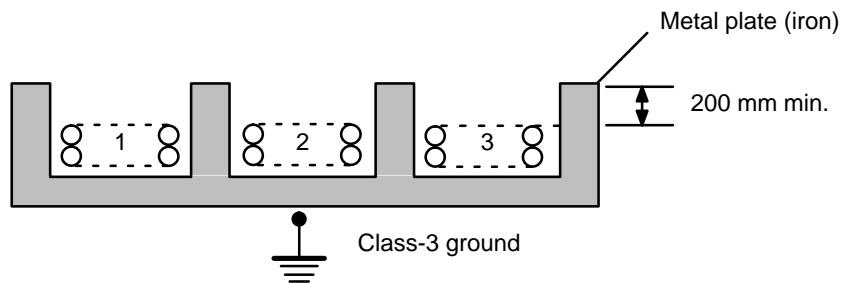

Where: 1 = I/O wiring
 2 = General control wiring
 3 = Power cables

4-11 System Design and Safety Considerations

When designing a C200HS system, be sure to consider the following points:

- Power supply system wiring and emergency stop circuit
- Interlock circuit
- Programmable Controller power interruptions

4-11-1 Power Supply System and Emergency Stop Circuit

The power section, control section, PC System, and the DC I/O system should all be wired separately.

An external relay should be used to form an emergency stop circuit that turns the power to the PC OFF in the event of an emergency. An emergency stop routine in the PC program is not sufficient to ensure safety. The circuit shown below is an example of an emergency stop circuit. Incorporate the PC RUN output terminal into an external relay circuit (CR1 in the diagram below) so that a PC breakdown or malfunction will not affect the entire system.

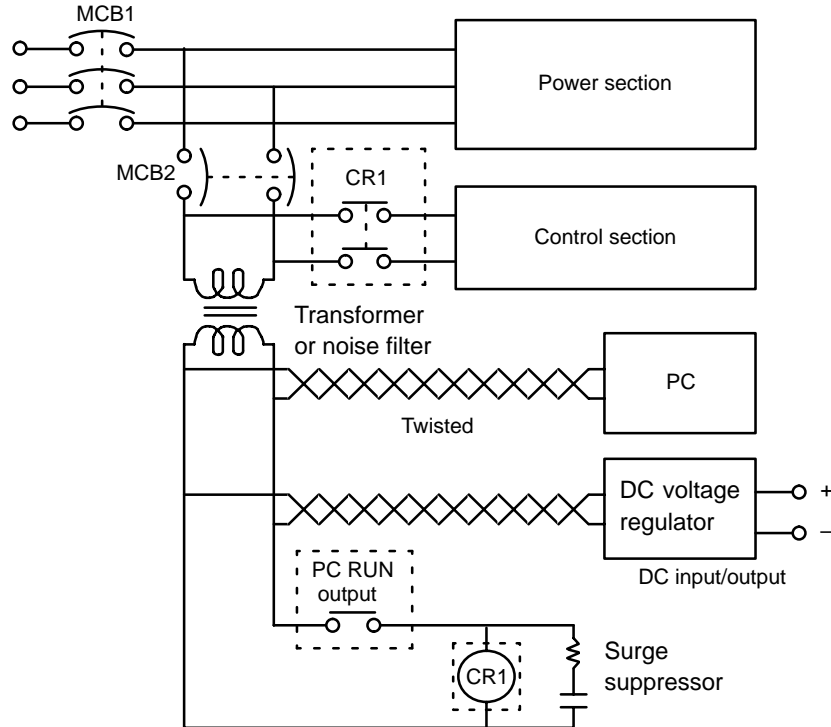

4-11-2 Interlock Circuit

When the PC controls an operation such as the clockwise and counterclockwise operation of a motor, provide an external interlock such as the one shown below to prevent both the forward and reverse outputs from turning ON at the same time.



This circuit prevents outputs MC1 and MC2 from ever both being ON at the same time. Even if the PC is programmed improperly or malfunctions, the motor is protected.

4-11-3 Programmable Controller Power Interruptions

A sequential circuit is built into the PC to handle power interruptions. This circuit prevents malfunctions due to momentary power loss or voltage drops. A timing diagram for the operation of this circuit is shown below.

The PC ignores all momentary power failures if the interruption lasts no longer than 10 ms. If the interruption lasts between 10 and 25 ms, the interruption may or may not be detected. If the supply voltage drops below 85% of the rated voltage for longer than 25 ms (less for the DC Power Supply), the PC will stop operating and the external outputs will be automatically turned OFF.

Operation is resumed automatically when the voltage is restored to more than 85% of the rated value. The diagram below shows the timing of PC operation and stopping during a power interruption. The time it takes to detect the power failure is shorter when the power supply is DC.

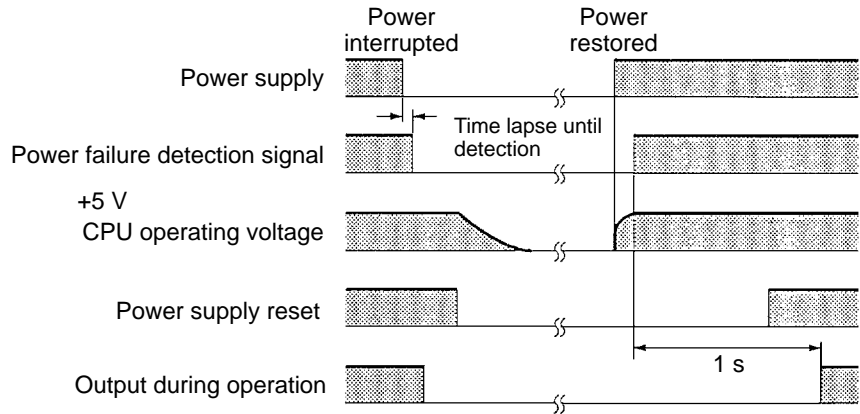

SECTION 5

Peripheral Devices and System Expansion

A Programming Console or IBM PC/AT running Ladder Support Software (LSS) or SYSMAC Support Software (SSS) can be used to program and monitor the C200HS PCs. This section provides general information about the Programming Console, LSS, SSS, and ways in which the C200HS System can be expanded for more versatility. For descriptions of new Programming Console operations, refer to the *C200HS Operation Manual (W235)*. For details concerning LSS and SSS, refer to the *Ladder Support Software Operation Manual (W237)* and the *SYSMAC Support Software Operation Manuals (Basics: W247; C-series PCs: W248)* respectively.

5-1	Programming Console	62
5-1-1	Nomenclature	63
5-2	Checking Initial C200HS Operation	64
5-3	Expanding the System	64
5-4	Special I/O Units	67
5-4-1	Required Mounting Conditions	67
5-4-2	Special I/O Units and Functions	67
5-5	Ladder Support Software (LSS)	73
5-6	SYSMAC Support Software (SSS)	73

5-1 Programming Console

There are two Programming Console models that can be used with the C200HS: the C200H-PRO27-E and the CQM1-PRO01-E. The following illustration shows how a Programming Console (a C200H-PRO27-E in this case) connects to the C200HS CPU.

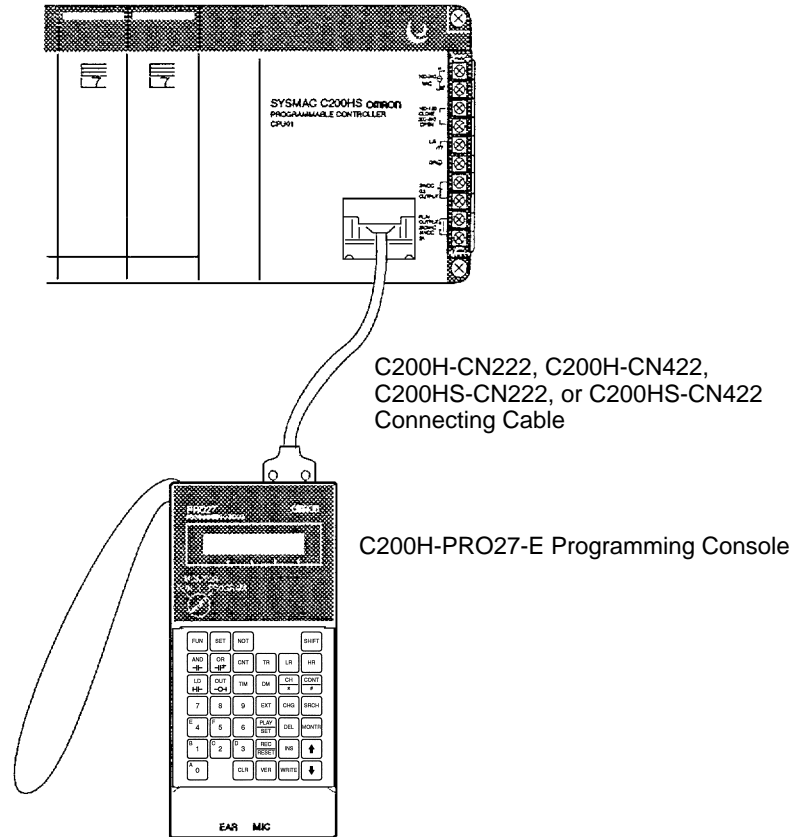

As indicated in the illustration, the C200H-PRO27-E Programming Console connects to the C200HS CPU with C200H-CN222, C200H-CN422, C200HS-CN222, or C200HS-CN422 Connecting Cable which must be purchased separately. The C200HS-CN222 and C200HS-CN422 Connecting Cables conform to EC directives.

An anti-static cover is provided for the C200HS-CN222/CN422 over the connector on the CPU side.

The CQM1-PRO01-E Programming Console comes with 2 m of Connecting Cable.

5-1-1 Nomenclature

The front panel of the Programming Console is shown below, taking the C200H-PRO27-E as an example.

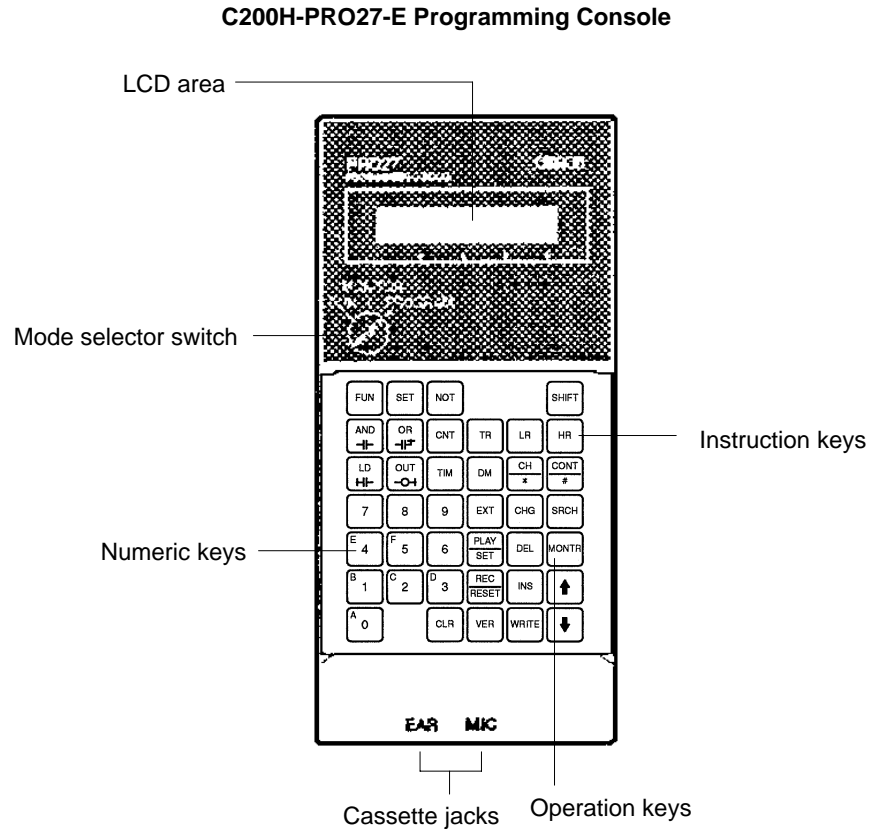

LCD Area

This window displays the program contents and monitor status.

Mode Selector Switch

PROGRAM MODE: Used for creating programs.
 RUN MODE: Used for executing the programs.
 MONITOR MODE: Used for monitoring C200HS status.

Keys

Instruction, numeric, and operation keys are used for inputting the program and data.

- Note**
1. The operations of C200H-PRO27-E and CQM1-PRO01-E Programming Consoles are the same.
 2. The following keys look different but have the same functions.

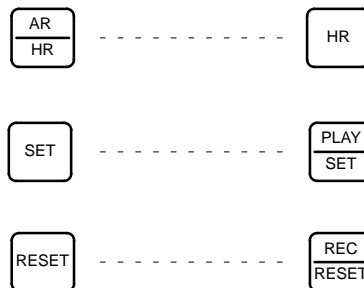

3. The cassette jacks are not used by the C200HS.

5-2 Checking Initial C200HS Operation

After the Programming Console has been connected, it can be used to check initial C200HS operation. Make sure that the Programming Console is properly connected and that the correct power supply is being provided, and then follow the procedure outlined below.

- 1, 2, 3... 1. Check to be sure that the Programming Console is in PROGRAM mode.

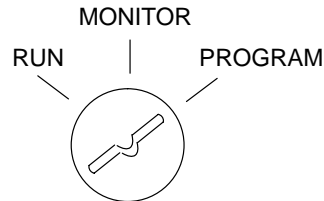

2. Turn on the power to the C200HS and check the CPU indicators. The green POWER indicator should light.
3. Check the Programming Console display and input the password (Clear and then Monitor Keys). If operation is normal, the display should appear as shown below.

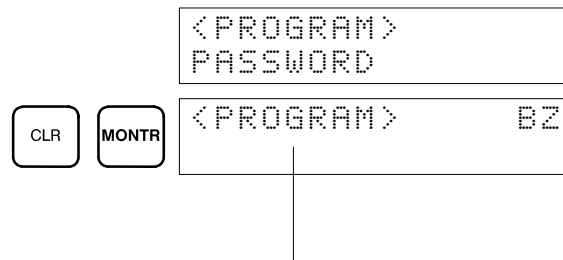

Indicates the mode set by the mode selector switch.

4. After checking C200HS operation, turn off the power. If operation is not normal, refer to *Section 6 Troubleshooting*.

5-3 Expanding the System

The C200HS System can be expanded to include a Host Link System (SYSMAC WAY), a PC Link System, Optical or Wired Remote I/O Systems (SYSMAC BUS) and SYSMAC NET Link or SYSMAC LINK System (C200HS-CPU31-E/CPU33-E only). All of these can be used in common with the C200H. In addition, the following Units can be connected: Interrupt Input Unit, Analog Timer Unit, and B7A Interface Unit. Specifications for all of these Units are provided in *Appendix B Specifications*.

Host Link System

A maximum of two Host Link Units can be mounted to slots in either the CPU Rack or an Expansion I/O Rack. The following Host Link Units are available:

- C200H-LK101-PV1 (optical cable)
- C200H-LK201-PV1 (RS-232C)
- C200H-LK202-V1 (RS-422)

For details, refer to the *SYSMAC C-series Rack PCs SYSMAC WAY – Host Link Units System Manual (W143)*.

SYSMAC LINK Systems

OMRON's SYSMAC LINK System is a communications network that connects up to 62 nodes to provide data links, data transfers, and datagram services.

- Data links provide automatic transfer of up to 918 words of data in the LR and/or DM Areas.
- Data transfers of up to 256 words each can be implemented by programming the NETWORK READ (RECV(98)) and NETWORK WRITE (SEND(90)) instructions in the user program.

- Data transfers via datagrams are also available using a command/response format.

The C200HS-CPU31-E or C200HS-CPU33-E must be used to enable application of SYSMAC LINK Systems. The C200H-CE001 and C200H-CE002 Bus Connection Units are used to connect SYSMAC LINK Units to the CPU, and the C200H-APS03 Auxiliary Power Supply Unit is used as a backup power supply for optical SYSMAC LINK Systems.

Note Refer to the *SYSMAC LINK System Manual (W174)* for further information.



SYSMAC NET Link Systems

OMRON's SYSMAC NET Link System is an FA-oriented limited-area network that connects up to 126 nodes to provide datagram services, data transfers, and data links.

- Data transfers via datagrams are implemented using a command/response format.
- Data transfers can also be implemented for up to 990 words each by programming the NETWORK READ (RECV(98)) and NETWORK WRITE (SEND(90)) instructions in the user program.
- Data links provide automatic transfer of up to 32 words of data in the LR Area and/or up to 99 words of data in other data areas.

The C200HS-CPU31-E or C200HS-CPU33-E must be used to enable application of SYSMAC NET Link Systems. The C200H-CE001 and C200H-CE002 Bus Connection Units are used to connect SYSMAC NET Link Units to the CPU, and the C200H-APS01 and C200H-APS02 Power Supply Adapters are used to connect to a central power supply (and must be mounted in the slot immediately to the left of the SYSMAC NET Link Unit).

Note Refer to the *SYSMAC NET Link System Manual (W178)* for further information.

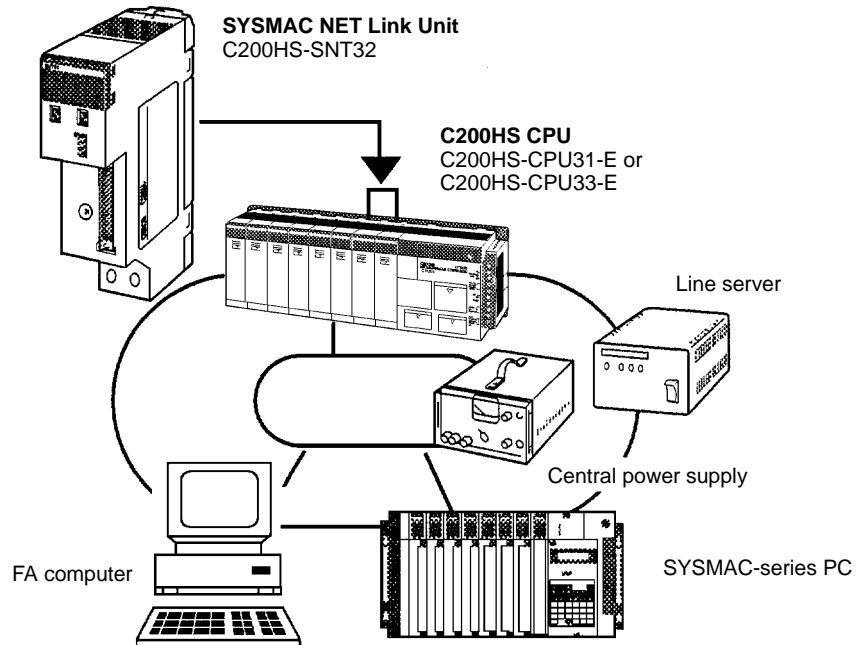

PC Link System

A PC Link System can be used to transfer data between PCs by means of LR 0000 through LR 6315. A maximum of two C200H-LK401 PC Link Units can be mounted to slots in either the CPU Rack or an Expansion I/O Rack. For details, refer to the *PC Link System Manual (W135)*.

Remote I/O Systems

A maximum of two Optical or Wired Remote I/O Master Units can be mounted to slots in either the CPU Rack or an Expansion I/O Rack. A maximum total of five Slave Racks, each with a single Slave Unit, can be connected. C500 Slave Racks can be used, but each C500 Slave Rack must be counted as two Racks in calculating the total. For details, refer to the *SYSMAC C-series Rack PCs Wired Remote I/O System Manual (W120)* or *SYSMAC C-series Optical Remote I/O System Manual (W136)*.

Optical Systems

Optical and Wired Units cannot be mixed. A maximum total of 64 (32 words) Optical I/O Units can be connected in an optical system.

- Note**
1. The number of Slave Racks is not related to the number of Master Units.
 2. If the number of Optical I/O Units exceeds 32, a B500-RPT01(-P) Repeater Unit is required.

Wired Systems

A maximum total of 32 I/O Interface Terminals and I/O Relay Terminals can be connected in a wired system. The number is unrelated to the number of Master Units mounted.

Special I/O Units

All of the Special I/O Units usable with the C200H can be used in common with the C200HS. A maximum of ten Special I/O Units (including PC Link Units) can be mounted to slots in either the CPU Rack, Expansion I/O Racks, or Slave Racks. For details, refer to the individual Special I/O Unit manuals and the following information.

5-4 Special I/O Units

It is possible to connect a variety of Special I/O Units to the C200HS in the same way as the C200H.

5-4-1 Required Mounting Conditions

A maximum of 10 Special I/O Units including PC Link Units can be mounted to any slot of CPU, Expansion I/O, and Slave Racks. I/O word numbers 100 to 199 and DM 1000 to DM 1999 are allocated to each Special I/O Unit.

High-density I/O Units can be mounted Remote I/O Slave Units only when the Remote I/O Slave Units are connected to C200H-RM001-PV1 or C200H-RM201 Remote I/O Master Units.

The number of Special I/O Units used with a Slave Rack is limited by data transmission considerations, as shown in the table below. The numbers in the table indicate the maximum number of Units of groups A, B, C, or D which can be used with a single Slave Rack.

A	B	C	D
High-speed Counter Units Position Control Units (NC111/112) ASCII Units Analog I/O Units ID Sensor Units Fuzzy Logic Units	High-density and Mixed I/O Units Temperature Control Units Cam Positioner Units Heat/Cool Temperature Control Unit PID Control Unit	Temperature Sensor Units Voice Units	Position Control Units (NC211)
4 units max.	8 units max.	6 units max.	2 units max.

Note 1. When a combination of Units from groups A, B, C, and D is used, the number from each group must satisfy both the following equations:

$$3A + B + 2C + 6D \leq 12$$

$$A + B + C + D \leq 8$$

2. Other Units can be added until the total number of Units reaches ten. If PC Link Units are used, the number of Units including the PC Link Units must not exceed ten.

5-4-2 Special I/O Units and Functions

Refer to page 103 for the specifications of each Special I/O Unit.

High-density I/O Units (Special I/O Units)

The TTL Input Unit, DC Input Unit, TTL Output Unit, Transistor Output Unit, TTL I/O Unit, and DC Input/Transistor Output Unit are High-density I/O Units.

The C200H-ID501, C200H-OD501, and C200H-MD501 are I/O Units for the TTL Unit.

Eight input points each of the C200H-ID501, C200H-ID215, C200H-MD501, C200H-MD115, and C200H-MD215 can be set for pulse input.

A High-density I/O Unit can retrieve pulse input, which is shorter in length than that of the High-density I/O Unit cycle time, as an input signal when the High-density I/O Unit is set for pulse input.

The C200H-MD501, C200H-MD115, and C200H-MD215 can each be set for 128 dynamic input points (64 points x two circuits) and the C200H-OD501 and C200H-OD215 can each be set for 128 dynamic output points (64 points x two circuits).



High-speed Counter Units

The High-speed Counter Units have the following six operation modes.

Linear, circular, preset, gate, latch, and sampling operation modes

The High-speed Counter Units, which have a counting speed of 50 kcps, can be used for phase-difference pulse input, adding and subtracting pulse input, and pulse and direction input. The High-speed Counter Units have eight-point output per single axis.

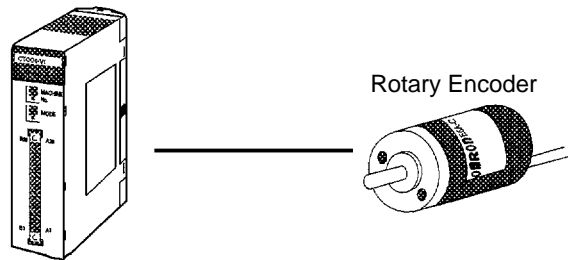

Position Control Units

The Position Control Units have pulse-train output, thus enabling connection to stepping motor drivers or servomotor drivers.

The C200H-NC111 and C200H-NC112 are for a single axis, and the C200H-NC211 is for two axes.

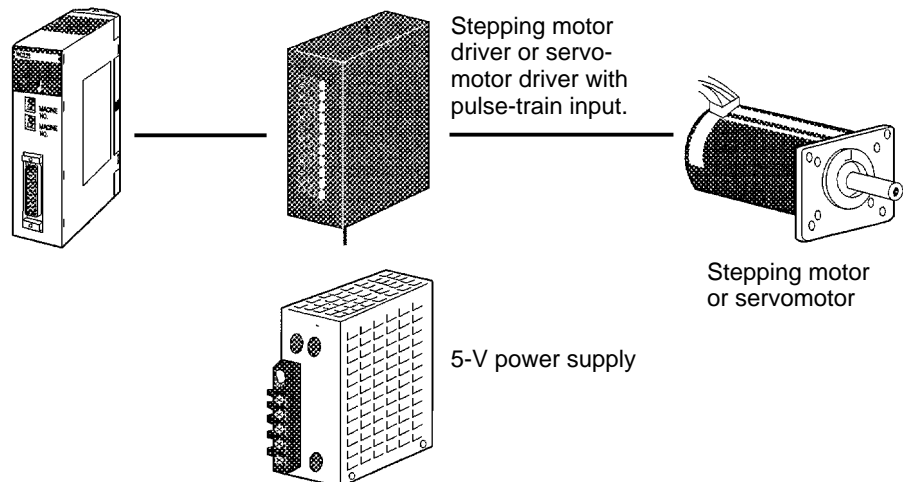

Analog I/O Units

The Analog Input (A/D) Units retrieve analog inputs and the Analog Output (D/A) Unit sends analog outputs.

The following Analog I/O Units are available:

C200H-AD001 with 4-point analog input, C200H-AD002 with 8-point analog input, C200H-DA001 with 2-point analog output, and C200H-DA002 with 4-point analog output

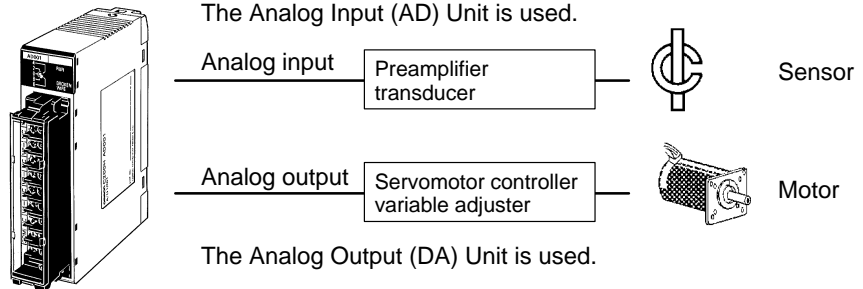

Temperature Sensor Units

The following table lists Temperature Sensor Unit models and available temperature sensors.

Only one kind of temperature sensor can be connected to the C200H-TS001 or C200H-TS002. Each Temperature Sensor Unit connects to a maximum of four temperature sensor inputs.

Model	Connectable temperature sensor
C200H-TS001	K (CA)/K (IC)
C200H-TS002	K (CA)/L (Fe-CuNi) (available for DIN)
C200H-TS101	JPt 100 Ω
C200H-TS102	Pt 100 Ω (available for DIN/1989JIS)

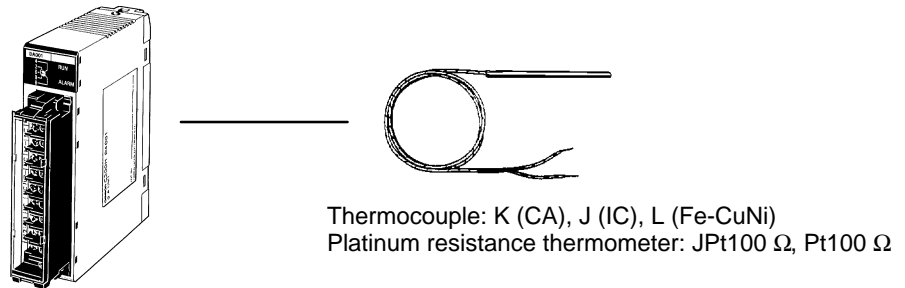

ASCII Unit

BASIC programs can be input to the ASCII Unit via its port 1 from any personal computer in terminal mode if the personal computer incorporates an RS-232C interface.

It is possible to write BASIC programs with an IBM PC/AT or compatible.

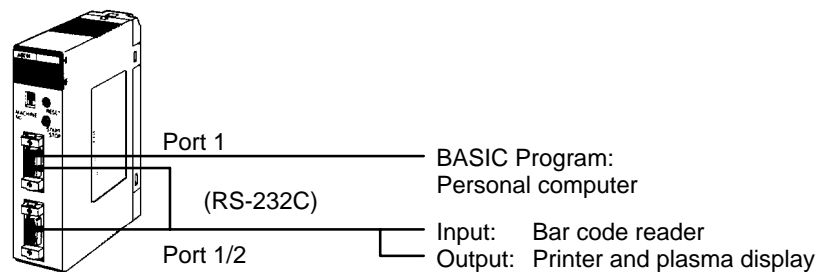

Voice Unit

Voice messages can be input from dynamic microphones or cassette tape recorders and output from loudspeakers or headsets via the Voice Unit.

The Voice Unit incorporates a sentence function and word combination function, either of which can be selected to record voice messages for 64 seconds maximum.

Voice can be saved on floppy disks with an IBM PC/AT or compatible.

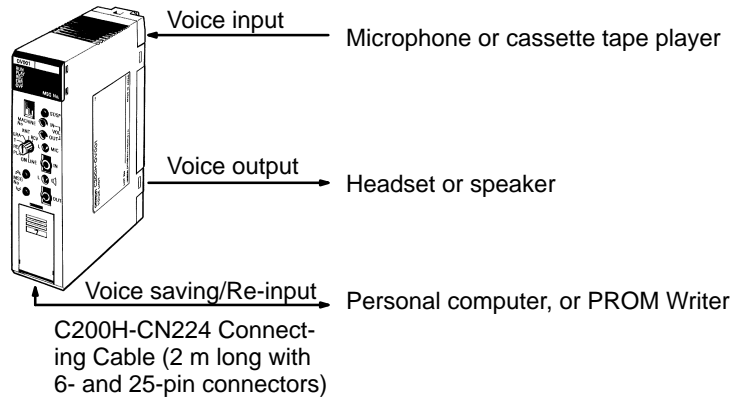

ID Sensor Units

The ID Sensor Units are used to construct non-contact information recognition systems.

By connecting a R/W Head or R/W Antenna to an ID Sensor Unit, data can be written to the Data Carrier attached to each moving object and the data of the Data Carrier can be read by the C200HS.

The following models of ID Sensor Units are available.

- Electromagnetic induction model: C200H-IDS01-V1
- Microwave model: C200H-IDS21

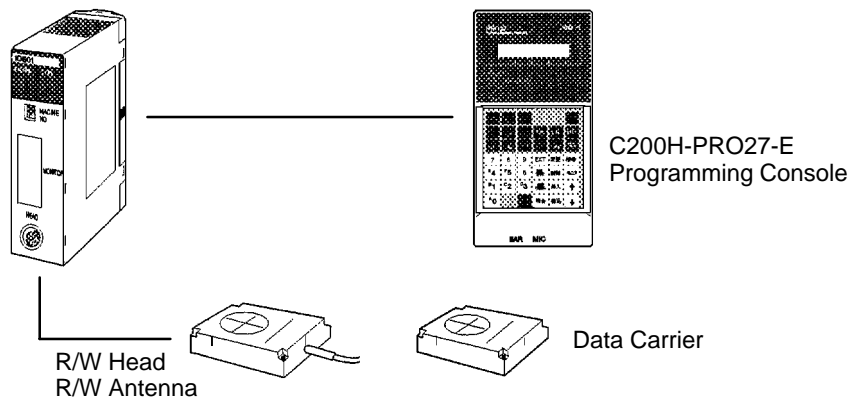

Fuzzy Logic Unit

The C200H-FZ001 Fuzzy Logic Unit incorporates a high-functional fuzzy Logic processor and allows high-speed fuzzy logic.

A personal computer can be connected to the Fuzzy Logic Unit via RS-232C cables for software development and monitoring. Use the C500-SU981-E Fuzzy Support Software for IBM PC/AT or compatible personal computers.



Temperature Control Units

Thermocouples or platinum resistance thermometers connect to the Temperature Control Unit. With the built-in selector of the Temperature Control Unit, ten kinds of thermocouples or two kinds of platinum resistance thermometers can be selected.

Select the control output of the Temperature Control Unit from the following.

Model	Temperature sensor input	Control output
C200H-TC001	Thermocouple: R, S, K (CA), J (IC), T (CC), E (CRC), B, N, L (IC), U (CC)	Transistor output
C200H-TC002		Voltage output
C200H-TC003		Current output
C200H-TC101	Platinum resistance thermometer: JPt100, Pt100	Transistor output
C200H-TC102		Voltage output
C200H-TC103		Current output

Temperature Control Unit

Data Setting Console

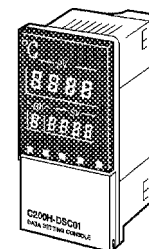
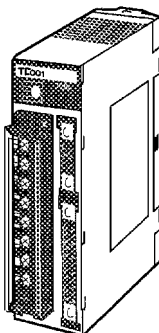

Cam Positioner Unit

A single C200H-CP114 Cam Positioner Unit is as powerful as 48 mechanical cams because it can complete jobs that normally require 48 mechanical cams. It is possible to set 16-point external output and 32-point internal output as cam output. The 32-point internal output can be retrieved as data by the C200HS.

Cam Positioner Unit

Data Setting Console

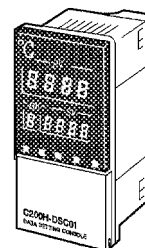
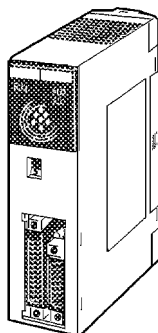

Heat/Cool Temperature Control Units

The Heat/Cool Temperature Control Units measure the temperature of an object with a connected temperature sensor (thermocouple or platinum resistance thermometer), and heats and cools according to a preset control mode.

Select the control output of the Heat/Cool Temperature Control Unit from the following.

Model	Temperature sensor input	Control output
C200H-TV001	Thermocouple: R, S, K (CA), J (IC), T (CC), E (CRC), B, N, L (IC), U (CC)	Transistor output
C200H-TV002		Voltage output
C200H-TV003		Current output
C200H-TV101	Platinum resistance thermometer: JPt100, Pt100	Transistor output
C200H-TV102		Voltage output
C200H-TV103		Current output

Heat/Cool Temperature Control Unit

Data Setting Console

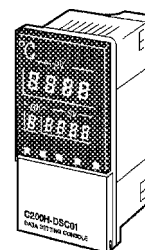
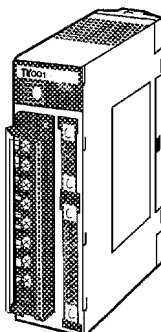

PID Control Unit

The PID Control Unit scales inputs from connected sensors and then carries out PID control according to preset control mode.

Select the control output of the PID Control Unit from the following.

Model	Control output
C200H-PID01	Transistor output
C200H-PID02	Voltage output
C200H-PID03	Current output

PID Control Unit

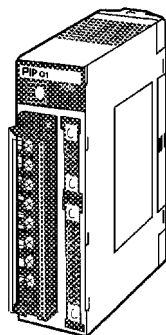

Data Setting Console

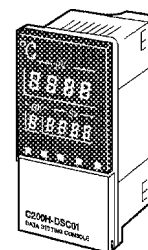

5-5 Ladder Support Software (LSS)

The LSS is a powerful support software package for the OMRON C-series Programmable Controllers (PCs). The LSS runs on an IBM PC/AT or compatible personal computer, and can be used to program, monitor and control PCs. While some PCs require a SYSMAC NET Link Unit, Host Link Unit, or Peripheral Interface Unit to connect the computer running LSS, the C200HS can be connected directly to the LSS via its peripheral or RS-232C port.

The LSS provides displays of various useful lists when the computer is operated offline and can be used to monitor operating conditions of the PC, and to read and write PC data. PC programs can be developed in a mnemonic or ladder diagram form.

When working in ladder diagram form, not only the program is displayed but also other information such as I/O, block, and instruction comments can be input and displayed. Moreover, the LSS allows more than one PC to be connected to and monitored using a single computer. The monitoring speed can be accelerated if the optional S3200-NSB11-E SYSMAC NET NSB is used.

For details concerning LSS, refer to the *Ladder Support Software Operation Manual (W237)*.

5-6 SYSMAC Support Software (SSS)

The SSS is an advanced software application that runs on IBM PC/AT or compatibles and is used to program, monitor, and otherwise control OMRON SYSMAC C-series PCs and SYSMAC CVM1 PCs. The C200HS can be connected directly to a computer running the SSS in exactly the same way as for the LSS.

The SSS can be used with any of the CVM1 PCs and with all of the many C-series PCs. The SSS automatically switches programming styles and other operations between the various PCs when a PC model is set in the SSS's System Setup.

All programs written on the Ladder Support Software or on the CV Support Software can be read and used by the SSS. Programs created for the C2000H or C200HS families of PCs can be converted for use with CVM1 PCs so that existing programs can be used with the newer PCs.

The SSS naturally supports all of the functionality for C-series PCs as the LSS, plus some new functions that facilitate fast, efficient programming and operation.

SECTION 6

Troubleshooting

The C200HS provides self-diagnostic functions to identify many types of abnormal system conditions. These functions minimize downtime and enable quick, smooth error correction.

This section provides information on hardware and software errors that occur during PC operation. It also provides troubleshooting charts for CPU Racks, Expansion I/O Racks, Input Units, and Output Units.

6-1	Alarm Indicators	76
6-2	Programmed Alarms and Error Messages	76
6-3	Reading and Clearing Errors and Messages	76
6-4	Error Messages	77
6-5	CPU Racks and Expansion I/O Racks	81
6-6	Input Units	82
6-7	Output Units	83

6-1 Alarm Indicators

The ALM/ERR indicator on the front of the CPU provides visual indication of an abnormality in the PC. When the indicator is ON (ERROR), a fatal error (i.e., ones that will stop PC operation) has occurred; when the indicator is flashing (ALARM), a nonfatal error has occurred.



Caution

The PC will turn ON the ALM/ERR indicator, stop program execution, and turn OFF all outputs from the PC for most hardware errors, for certain fatal software errors, or when FALS(07) is executed in the program (see tables on following pages). PC operation will continue for all other errors. It is the user's responsibility to take adequate measures to ensure that a hazardous situation will not result from automatic system shutdown for fatal errors and to ensure that proper actions are taken for errors for which the system is not automatically shut down. System flags and other system and/or user-programmed error indications can be used to program proper actions.

6-2 Programmed Alarms and Error Messages

FAL(06), FALS(07), and MSG(46) can be used in the program to provide user-programmed information on error conditions. With these three instructions, the user can tailor error diagnosis to aid in troubleshooting.

FAL(06) is used with a FAL number other than 00, which is output to the SR area when FAL(06) is executed. Executing FAL(06) will not stop PC operation or directly affect any outputs from the PC.

FALS(07) is also used with a FAL number, which is output to the same location in the SR area when FALS(07) is executed. Executing FALS(07) will stop PC operation and will cause all outputs from the PC to be turned OFF.

When FAL(06) is executed with a function number of 00, the current FAL number contained in the SR area is cleared and replaced by another, if more have been stored in memory by the system.

When MSG(46) is used a message containing specified data area words is displayed onto the Programming Console or another Programming Device.

The use of these instructions is described in detail in the *C200HS Operation Manual (W235)*.

6-3 Reading and Clearing Errors and Messages

System error messages can be displayed onto the Programming Console or other Programming Device.

On the Programming Console, press the CLR, FUN, and MONTR keys. If there are multiple error messages stored by the system, the MONTR key can be pressed again to access the next message. If the system is in PROGRAM mode, pressing the MONTR key will clear the error message, so be sure to write down all message errors as you read them. (It is not possible to clear an error or a message while in RUN or MONITOR mode; the PC must be in PROGRAM mode.) When all messages have been cleared, "ERR CHK OK" will be displayed.

Details on accessing error messages from the Programming Console are provided in the *C200HS Operation Manual (W235)*. Procedures for the LSS are provided in the *LSS Operation Manual (W237)*.

6-4 Error Messages

There are basically three types of errors for which messages are displayed: initialization errors, non-fatal operating errors, and fatal operating errors. Most of these are also indicated by FAL number being transferred to the FAL area of the SR area.

The type of error can be quickly determined from the indicators on the CPU, as described below for the three types of errors. If the status of an indicator is not mentioned in the description, it makes no difference whether it is lit or not.

After eliminating the cause of an error, clear the error message from memory before resuming operation.

Asterisks in the error messages in the following tables indicate variable numeric data. An actual number would appear on the display.

Initialization Errors

The following error messages appear before program execution has been started. The POWER indicator will be lit and the RUN indicator will not be lit for either of these. The RUN output will be OFF for each of these errors.

Error and message	FAL no.	Probable cause	Possible correction
Waiting for Special I/O or Interrupt Input Units 	None	A Special I/O Unit or Interrupt Input Unit has not initialized.	Perform the I/O Table Read operation to check unit numbers. Replace Unit if it is indicated by "\$" only in the I/O table. (High-density I/O Units will not appear on I/O Table Read display for all peripheral devices.)
Waiting for Remote I/O 	None	Power to Remote I/O Unit is off or terminator cannot be found.	Check power supply to Remote I/O Units, connections between Remote I/O Units, and terminator setting.

Non-fatal Operating Errors

The following error messages appear for errors that occur after program execution has been started. PC operation and program execution will continue after one or more of these errors have occurred. For each of these errors, the POWER and RUN indicators will be lit and the ALM/ERR indicator will be flashing. The RUN output will be ON.

Error and message	FAL no.	Probable cause	Possible correction
FAL error 	01 to 99	FAL(06) has been executed in program. Check the FAL number to determine conditions that would cause execution (set by user).	Correct according to cause indicated by FAL number (set by user).
Interrupt Input Unit error 	8A	An error occurred in data transfer between the Interrupt Input Unit and the CPU.	Replace the Interrupt Input Unit.

Error and message	FAL no.	Probable cause	Possible correction
Interrupt subroutine error <div style="border: 1px solid black; padding: 5px; width: fit-content;"> SYS FAIL FAL8B </div>	8B	Interrupt subroutine containing Special I/O Unit refresh was too long. Cyclic Special I/O Unit refreshing was not disabled for interrupt subroutine refresh.	Check the interrupt subroutine and PC Setup.
High-density I/O Unit error <div style="border: 1px solid black; padding: 5px; width: fit-content;"> SYS FAIL FAL9A </div>	9A	An error occurred in data transfer between a High-density I/O Unit and the CPU.	Check AR 0205 to AR 0214 to identify the Unit with a problem, replace the Unit, and restart the PC.
PC Setup error <div style="border: 1px solid black; padding: 5px; width: fit-content;"> SYS FAIL FAL9B </div>	9B	An error has been detected in the PC Setup. This error will be generated when the setting is read or used for the first time.	Check an correct PC Setup settings.
Memory Cassette Transfer error <div style="border: 1px solid black; padding: 5px; width: fit-content;"> SYS FAIL FAL9D </div>	9D	An error has occurred during data transmission between UM and a Memory Cassette because: Not in PROGRAM Mode. UM or Memory Cassette is read-only. Insufficient capacity in UM or Memory Cassette. A checksum error occurred in the Memory Cassette	Make sure that the PC is in PROGRAM mode. Make sure that the Memory Cassette is not write-protected. Make sure that the UM and Memory Cassette capacity is sufficient. Make sure the SYSMAC NET data link is not operating and transfer again (SR 27011 will be ON). Transfer the data again.
Cycle time overrun <div style="border: 1px solid black; padding: 5px; width: fit-content;"> CYCLE TIME OVER </div>	F8	Watchdog timer has exceeded 100 ms.	Program cycle time is longer than recommended. Reduce cycle time if possible.
I/O table verification error <div style="border: 1px solid black; padding: 5px; width: fit-content;"> I/O VER ERR </div>	E7	Unit has been removed or replaced by a different kind of Unit, making I/O table incorrect.	Use I/O Table Verify Operation to check I/O table and either connect dummy Units or register the I/O table again.
Remote I/O error <div style="border: 1px solid black; padding: 5px; width: fit-content;"> REMOTE ERR Remote I/O Master Unit number * </div>	B0 or B1	Error occurred in transmissions between Remote I/O Units.	Check transmission line between PC and Master and between Remote I/O Units.
Special I/O Unit error <div style="border: 1px solid black; padding: 5px; width: fit-content;"> SIOU ERR </div>	D0	Error has occurred in PC Link Unit, Remote I/O Master Unit, between a Host Link, SYSMAC LINK, or SYSMAC NET Link Unit and the CPU, or in refresh between Special I/O Unit and the CPU.	Determine the unit number of the Unit which caused the error (AR 00), correct the error, and toggle the appropriate Restart Bit in AR 01, SR 250, or SR 252. If the Unit does not restart, replace it.
Battery error <div style="border: 1px solid black; padding: 5px; width: fit-content;"> BATT LOW </div>	F7	Backup battery is missing or its voltage has dropped.	Check battery, and replace if necessary.

Communications Errors

The COMM or COMM 1 indicator will go out for errors in communications between the peripheral port and a peripheral device and COMM 2 will go out for errors in communications between the RS-232C port and a peripheral device. If an error is indicated, check the communications path and the C200HS program. The ports can be reset using the Peripheral Port Reset Bit (SR 25208) and the RS-232C Port Reset Bit (SR 25209).

Fatal Operating Errors

The following error messages appear for errors that occur after program execution has been started. PC operation and program execution will stop and all outputs from the PC will be turned OFF when any of the following errors occur. No CPU indicators will be lit for the power interruption error. For all other fatal operating errors, the POWER and ALM/ERR indicators will be lit. The RUN output will be OFF.

Error and message	FAL no.	Probable cause	Possible correction
Power interruption No message.	00	Power has been interrupted for at least 10 ms.	Check power supply voltage and power lines. Try to power-up again.
CPU error No message.	None	Watchdog timer has exceeded maximum setting (default setting: 130 ms).	Restart system in PROGRAM mode and check program. Reduce cycle time or reset watchdog timer if longer time required. (Consider effects of longer cycle time before resetting.)
Memory error MEMORY ERR	F1	SR 27211 ON: A checksum error has occurred in the PC Setup (DM 6600 to DM 6655).	Check the PC Setup.
		SR 27212 ON: A checksum error has occurred in the program, indicating an incorrect instruction.	Check the program.
		SR 27213 ON A checksum error has occurred in an expansion instruction change.	
		SR 27214 ON: Memory Cassette was installed or removed with the power on.	Install the Memory Cassette correctly.
		SR 27215 ON: Autoboot error.	Check whether the CPU memory is protected or a checksum error occurred in the Memory Cassette.
No END(01) instruction NO END INST	F0	END(01) is not written anywhere in program.	Write END(01) at the final address of the program.
I/O bus error I/O BUS ERR * Rack no.	C0 to C2	Error has occurred in the bus line between the CPU and I/O Units.	The rightmost digit of the FAL number will indicate the number of the Rack where the error was detected. Check cable connections between the I/O Units and Racks.

Error and message	FAL no.	Probable cause	Possible correction
<p>Too many Units</p> <div style="border: 1px solid black; padding: 5px; width: fit-content;">I/O UNIT OVER</div>	E1	<p>Two or more Special I/O Units are set to the same unit number</p> <p>Two or more Group-2 High-density I/O Units or B7A Interface Units are set to the same I/O number or I/O word.</p> <p>The I/O number of a 64-pt Group-2 High-density I/O Unit is set to 9.</p> <p>SYSMAC NET or SYSMAC LINK systems are using duplicate settings (CPU31/33-E only).</p> <p>More than one Interrupt Unit is mounted.</p>	<p>Perform the I/O Table Read operation to check unit numbers, and eliminate duplications. (High-density I/O Units other than Group-2 are Special I/O Units, too.)</p> <p>Set unit numbers of 64-pt Group-2 Units to numbers other than 9.</p> <p>Correct the settings.</p> <p>Mount only one Interrupt Unit.</p>
<p>Input-output I/O table error</p> <div style="border: 1px solid black; padding: 5px; width: fit-content;">I/O SET ERROR</div>	E0	<p>Input and output word designations registered in I/O table do not agree with input/output words required by Units actually mounted.</p>	<p>Check the I/O table with I/O Table Verification operation and check all Units to see that they are in correct configuration. When the system has been confirmed, register the I/O table again.</p>
<p>FALS error</p> <div style="border: 1px solid black; padding: 5px; width: fit-content;">SYS FAIL FALS**</div>	01 to 99 or 9F	<p>FALS has been executed by the program. Check the FAL number to determine conditions that would cause execution (Set by user or by system).</p>	<p>Correct according to cause indicated by FAL number. If FAL number is 9F, check watchdog timer and cycle time, which may be too long. 9F will be output when FALS(07) is executed and the cycle time is between 120 and 130 ms.</p>

Other Error Messages

A number of other error messages are detailed within this manual. Errors in program input and debugging and errors in cassette tape operation are detailed in the *C200HS Operation Manual (W235)*. Information on error flags is also contained in the *C200HS Operation Manual (W235)*.

6-5 CPU Racks and Expansion I/O Racks

Error	Probable cause	Possible correction
POWER indicator does not light.	A fuse is blown.	Replace the fuse.
Fuses are frequently blown.	The voltage selector terminal setting is wrong.	Correct the voltage selector terminal setting.
	Pattern short-circuiting or damage from fire	Replace the CPU or Power Supply Unit.
RUN indicator does not light.	The program has an error (no END instruction).	Correct the program.
	The voltage selector terminal setting is wrong.	Correct the voltage selector terminal setting.
	A power supply line is defective.	Replace the CPU.
	Special I/O Units are assigned overlapping unit numbers.	Correct the unit number assignments.
	A Slave Unit's power supply is turned off, or no Unit is set as the terminator.	Turn on the power to the Slave Unit, or set a Unit as the terminator.
RUN indicator is lit, but RUN output does not turn on.	The power circuit is defective.	Replace the CPU.
Relays do not operate from a particular number onwards.	The I/O bus is defective.	Replace the Backplane.
Outputs (or inputs) turn ON for particular Relay numbers.		
All the bits from a particular Unit turn ON.		

6-6 Input Units

Error	Probable cause	Possible correction
Indicator lights are turned off, and no inputs turn ON.	No external input power supply is provided.	Provide a power supply.
	The external input voltage is low.	Supply the rated voltage.
	Terminal screws are loose.	Tighten the terminal screws.
	Terminal block connectors are making poor contact.	Securely lock the connectors, or replace them if necessary.
Indicator lights are turned ON, but no inputs turn ON.	The input circuit is defective.	Replace the Unit.
All inputs remain ON, and will not turn OFF.	The input circuit is defective.	Replace the Unit.
Inputs do not turn ON for particular Relay numbers.	An input device is defective.	Replace the input device.
	Input wiring is disconnected.	Check the input wiring.
	Terminal screws are loose.	Tighten the terminal screws.
	Terminal block connectors are making poor contact.	Securely lock the connectors, or replace them if necessary.
	The ON time for external inputs is too short.	Adjust the input device.
	The input circuit is defective.	Replace the Unit.
	An input bit address is used for an OUT instruction in the program.	Correct the program.
Inputs do not turn OFF for particular Relay numbers.	The input circuit is defective.	Replace the Unit.
	An input bit address is used for an OUT instruction in the program.	Correct the program.
Inputs are turning ON and OFF irregularly.	The external input voltage is low.	Supply the rated voltage.
	There is malfunctioning due to noise.	Apply noise countermeasures such as installing a surge suppressor, installing an isolation transformer, and using shielded cables.
	Terminal screws are loose.	Tighten the terminal screws.
	Terminal block connectors are making poor contact.	Securely lock the connectors, or replace them if necessary.
Malfunctioning Relays are in groups of eight.	Common terminal screws are loose.	Tighten the terminal screws.
	Terminal block connectors are making poor contact.	Securely lock the connectors, or replace them if necessary.
	The CPU is defective.	Replace the CPU.
Operation is normal, but the input indicator does not light.	The LED is defective.	Replace the Unit.

6-7 Output Units

Error	Probable cause	Possible correction
No outputs turn ON.	A load power supply is not provided.	Provide the power supply.
	The load power supply voltage is low.	Provide the rated voltage.
	Terminal screws are loose.	Tighten the terminal screws.
	Terminal block connectors are making poor contact.	Securely lock the connectors, or replace them if necessary.
	A fuse is blown.	Replace the fuse.
	I/O bus connectors are making poor contact.	Replace the Unit.
	The output circuit is defective.	Replace the Unit.
Outputs all fail to turn OFF.	The output circuit is defective.	Replace the Unit.
Indicators do not light, and the outputs for particular Relay numbers do not turn ON.	The output ON time is too short.	Correct the program.
	The output circuit is defective.	Replace the Unit.
	The program's OUT instruction bit addresses overlap.	Correct the program.
Indicators light, but the outputs for particular Relay numbers do not turn ON.	An output device is defective.	Replace the output device.
	Output wiring is disconnected.	Check the output wiring.
	Terminal screws are loose.	Tighten the terminal screws.
	Terminal block connectors are making poor contact.	Securely lock the connectors, or replace them if necessary.
	Output Relays are defective.	Replace the Relays.
	The output circuit is defective.	Replace the Unit.
Indicator lights are off, but the outputs for particular Relay numbers do not turn OFF.	Output Relays are defective.	Replace the Relays.
	There is faulty restoration due to leakage current or residual current.	Replace the external load or add a dummy resistor.
Indicators light, and the outputs for particular Relay numbers do not turn OFF.	The output circuit is defective.	Replace the Unit.
	The program's OUT instruction bit addresses overlap.	Correct the program.
Outputs are turning ON and OFF irregularly.	The load power supply voltage is low.	Supply the rated voltage.
	The program's OUT instruction bit addresses overlap.	Correct the program.
	There is malfunctioning due to noise.	Apply noise countermeasures such as installing a surge suppressor, installing an isolation transformer, and using shielded cables.
	Terminal screws are loose.	Tighten the terminal screws.
	Terminal block connectors are making poor contact.	Securely lock the connectors, or replace them if necessary.
Malfunctioning Relays are in groups of eight.	Common terminal screws are loose.	Tighten the terminal screws.
	Terminal block connectors are making poor contact.	Securely lock the connectors, or replace them if necessary.
	A fuse is blown.	Replace the fuse.
	The CPU is defective.	Replace the CPU.
Operation is normal, but the output indicator does not light.	The LED is defective.	Replace the Unit.

SECTION 7

Inspection and Maintenance

Certain consumable items in a PC (such as fuses, relays, and batteries) need occasional replacement. This section explains how to replace these items. Always keep spare items on hand so that they can be used as immediate replacements when needed.

7-1	CPU and Power Supply Fuses	86
7-2	Output Unit Fuses	86
7-3	Output Unit Relays	87
7-4	Batteries	90

7-1 CPU and Power Supply Fuses

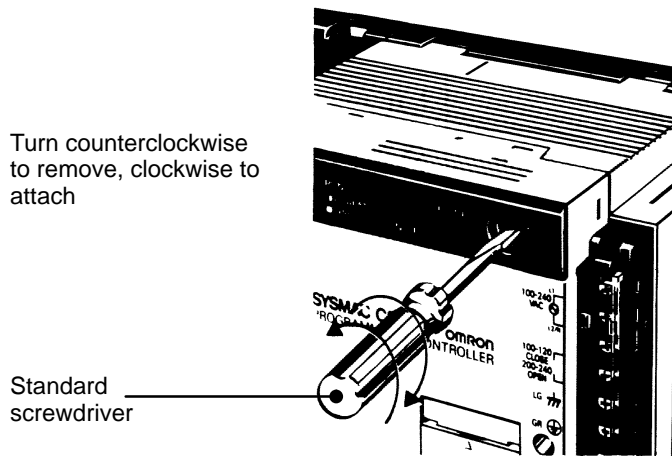

To replace a fuse, follow the steps below.

- 1, 2, 3...**
1. Turn OFF the power to the PC.
 2. Remove the fuse holder by turning it approximately 50° counterclockwise with a standard screwdriver.
 3. Remove the fuse from the holder.
 4. Insert a new fuse.
 5. Reattach the fuse holder by turning it approximately 50° clockwise with a standard screwdriver.

7-2 Output Unit Fuses

To replace a fuse, follow the steps below. Use only UL/CSA certified replacement fuses.

Fuse Specifications (5.2-dia.x20)

Model	F indicator (fuse blowout detection circuit)	Rating
C200H-OD411	Yes	5 A 125 V
C200H-OD211	No	
C200H-OD212	No	8 A 125 V
C200H-OD213	Yes	
C200H-OA121-E	Yes	5 A 125 V
C200H-OA122-E	Yes	
C200H-OA221	Yes	5 A 250 V
C200H-OA222V	No	3 A 250 V
C200H-OA223	Yes	5 A 250 V
C200H-OA224	No	3.15 A 250 V

- 1, 2, 3...**
1. Turn OFF the power to the PC.
 2. Detach the terminal block by unlocking the lock levers at the top and bottom of the terminal block.

3. While pushing down the lock lever on the Backplane with a screwdriver as shown below, remove the Output Unit.

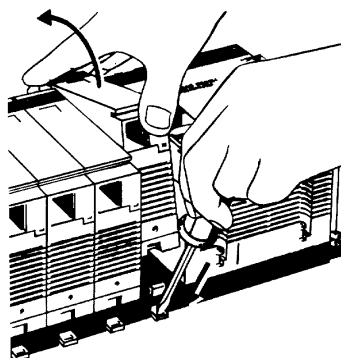

4. Using a Phillips screwdriver, remove the screw from the top of the Unit.
5. Using a flat-blade screwdriver, detach the case from the Unit.

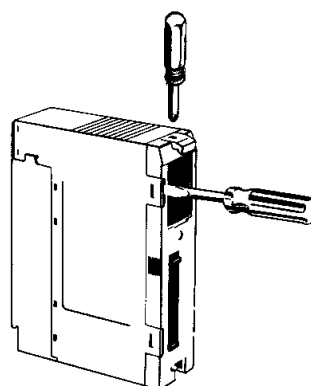

6. Pull out the printed circuit board.
7. Insert a new fuse. A spare fuse is provided inside the rear of the case when the Unit is delivered.
8. Reassemble in reverse order of assembly.

- Note**
1. Use UL or CSA approved fuses if the UL or CSA standards must be satisfied. For further details, consult the fuse manufacturer.
 2. Fuses in High-density I/O Units cannot be replaced by the user. Refer to your OMRON dealer for service.

7-3 Output Unit Relays

The following Output Units provide relay sockets that allow the Relays to be replaced if they should go bad. Use the Relay listed in the table.

Unit	Relay
C200H-OC221	G6B-1174P-FD-US, 24 VDC
C200H-OC222	
C200H-OC223	
C200H-OC224	
C200H-OC225	
C200H-OC222V	G6R-1, 24 VDC
C200H-OC224V	
C200H-OC226	

To replace a Relay, follow the steps below:

- 1, 2, 3...
1. Turn OFF the power to the PC.
 2. Detach the terminal block by unlocking the lock levers at the top and bottom of the terminal block.
 3. While pushing down the lock lever on the Backplane with a screwdriver as shown below, remove the Output Unit.



4. Using a Phillips screwdriver, remove the screw from the top of the Unit.
5. Using a flat-blade screwdriver, detach the case from the Unit.



6. Pull out the printed circuit board. The Relays are placed on the PC boards of individual Units as shown in the figures below.

OC221/OC224

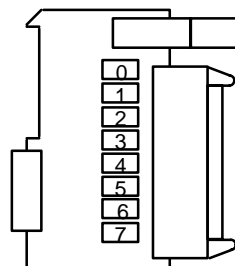

OC222

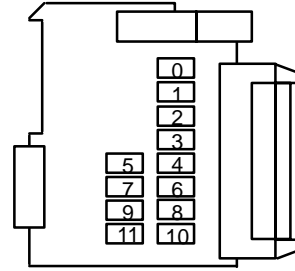

OC223

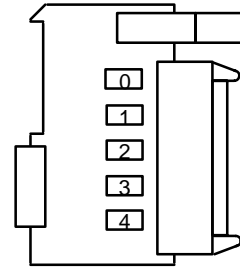

OC225

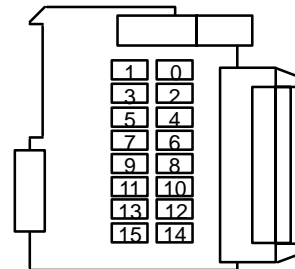

OC222V

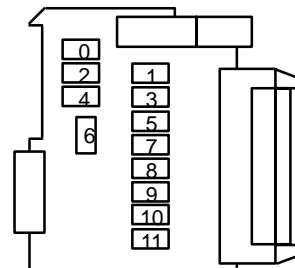

OC224V

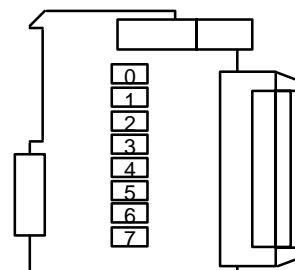

OC226

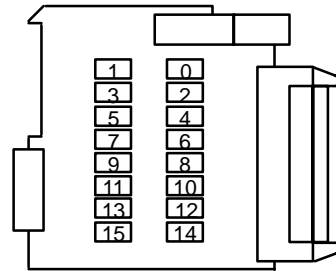

7. A Relay puller is provided inside the rear of the case when the Unit is delivered. Use the Relay puller to pull out the Relay as shown below. Insert a new Relay.

Relays for the C200H-OC222V/OC224V/OC226V can be replaced without using the Relay puller.

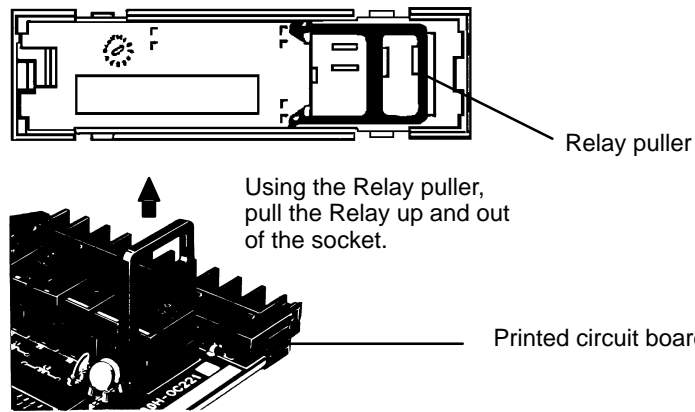

8. Reassemble in reverse order of assembly.

Caution Check the pin arrangement before inserting a new Relay into the socket. Pins can only be inserted one way, so do not try to force them if they do not go in easily. Applying too much force can bend the pins and render them unusable.

7-4 Batteries

DANGER Batteries can burn, explode, or leak. Absolutely do not short-circuit across the terminals, attempt to recharge batteries, or take them apart, heat them, or expose them to fire.

When the battery is nearly discharged, the ALARM indicator blinks and the message "BATT FAIL" appears on the Programming Console. When this occurs, replace the battery within one week to avoid loss of data.

The normal battery service life is five years at 25°C. The service life will be shortened if used at temperatures higher than that.

The Battery Fail Flag is allocated to 25308 for the C200HS.

The battery comes together with its connector as a set. To replace the Battery Set (C200H-BAT09), follow the steps below. The entire replacement must be completed within five minutes to ensure that the data will not be lost.

- 1, 2, 3... 1. Turn OFF the power to the PC. (If the power was not already ON, turn the power ON for at least one minute before turning the power OFF.)

2. Remove the cover from the battery compartment of the CPU Unit.
3. Remove the old Battery Set.
4. Install the new Battery Set as shown in the following diagram.

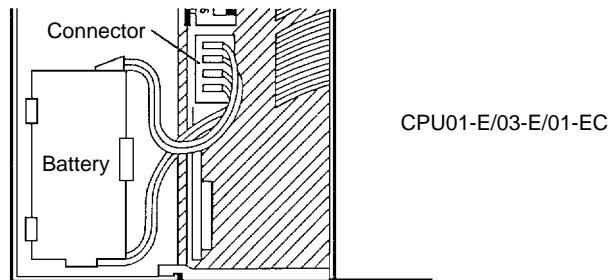

5. Replace the cover of the battery compartment.
6. Press CLR, FUN, MONTR, MONTR or just turn the power to the PC OFF and then ON again to clear the error message on the Programming Console.

Appendix A

Standard Models

C200HS Racks

Name		Specifications		Model number		
Backplane (same for all Racks)		10 slots		C200H-BC101-V2		
		8 slots		C200H-BC081-V2		
		5 slots		C200H-BC051-V2		
		3 slots		C200H-BC031-V2		
CPU Rack	CPU	100 to 120/200 to 240 VAC w/built-in power supply	---	C200HS-CPU01-E		
			Conforms to EC directives (see note)	C200HS-CPU01-EC		
			RS-232C port	C200HS-CPU21-E		
			RS-232C port and conforms to EC directives	C200HS-CPU21-EC		
		RS-232C port and SYSMAC NET/ SYSMAC LINK supported	C200HS-CPU31-E			
		24 VDC w/built-in power supply	Conforms to EC directives (see note)	C200HS-CPU03-E		
			RS-232C port	C200HS-CPU23-E		
			RS-232C port and SYSMAC NET/ SYSMAC LINK supported	C200HS-CPU33-E		
	Memory Cassette	EPROM Chip; 27256; 150 ns		ROM-JD-B		
		EPROM Chip; 27512; 150 ns		ROM-KD-B		
		EEPROM; 16K words		C200HS-ME16K		
		EPROM; 16K words		C200HS-MP16K		
	Expansion I/O Racks	I/O Power Supply Unit	100 to 120/200 to 240 VAC (switchable)		C200H-PS221	
				Conforms to EC directives	C200H-PS221-C	
24 VDC			Conforms to EC directives (see note)	C200H-PS211		
I/O Connecting Cable (max. total length: 12 m)		30 cm		C200H-CN311		
		70 cm		C200H-CN711		
		2 m		C200H-CN221		
		5 m		C200H-CN521		
		10 m		C200H-CN131		
Slave Racks		Remote I/O Slave Unit	100 to 120/200 to 240 VAC (switchable)		APF/PCF	C200H-RT001-P
			24 VDC			C200H-RT002-P
			100 to 120/200 to 240 VAC (switchable)		Wired	C200H-RT201
			Conforms to EC directives	C200H-RT201-C		
	24 VDC		C200H-RT202			

Note: Units with lot numbers □□Z5 (Dec. 1995) or later.

C200H Standard I/O Units

Name		Specifications		Model number	
Input Units	AC Input Unit	8 pts	100 to 120 VAC	C200H-IA121	
		16 pts	100 to 120 VAC	C200H-IA122/IA122V	
		8 pts	200 to 240 VAC	C200H-IA221	
		16 pts	200 to 240 VAC	C200H-IA222/IA222V	
	DC Input Unit	8 pts	No-voltage contact; NPN	C200H-ID001	
		8 pts	No-voltage contact; PNP	C200H-ID002	
		8 pts	12 to 24 VDC	C200H-ID211	
		16 pts	24 VDC	C200H-ID212	
	AC/DC Input Unit	8 pts	12 to 24 VAC/DC	C200H-IM211	
		16 pts	24 VAC/DC	C200H-IM212	
	Interrupt Input Unit ¹	8 pts	12 to 24 VDC	C200HS-INT01	
Output Units	Contact Output Unit	8 pts	2 A, 250 VAC/24 VDC (For resistive loads)	C200H-OC221	
		12 pts	2 A, 250 VAC/24 VDC (For resistive loads)	C200H-OC222	
		16 pts	2 A, 250 VAC/24 VAC (For resistive loads)	C200H-OC225 ^{2, 3}	
		5 pts	2 A, 250 VAC/24 VDC (For resistive loads) Independent commons	C200H-OC223	
		8 pts	2 A, 250 VAC/24 VDC (For resistive loads) Independent commons	C200H-OC224	
		12 pts	2 A, 250 VAC/24 VDC (For resistive loads)	C200H-OC222V	
		16 pts	2 A, 250 VAC/24 VDC (For resistive loads)	C200H-OC226	
		8 pts	2 A, 250 VAC/24 VDC (For resistive loads) Independent commons	C200H-OC224V	
	Triac Output Unit	8 pts	1 A, 120 VAC	C200H-OA121-E	
		8 pts	1.2 A, 120 VAC	C200H-OA122-E	
		8 pts	1.2 A 250 VAC	C200H-OA223	
		12 pts	0.3 A, 250 VAC	C200H-OA222V	
		12 pts	0.5 A, 250 VAC	C200H-OA224	
		Transistor Output Unit	8 pts	1 A, 12 to 48 VDC	C200H-OD411
	12 pts		0.3 A, 24 VDC	C200H-OD211	
	16 pts		0.3 A, 24 VDC	C200H-OD212 ²	
	8 pts		2.1 A, 24 VDC	C200H-OD213	
	8 pts		0.8 A, 24 VDC; source type (PNP); with load short protection	C200H-OD214	
	8 pts		5 to 24 VDC; source type (PNP)	C200H-OD216	
	12 pts		5 to 24 VDC; source type (PNP)	C200H-OD217	
	16 pts		1.0 A, 24 VDC; source type (PNP); with load short protection	C200H-OD21A	
	Analog Timer Unit		4 timers	0.1 to 1 s/1 to 10 s/10 to 60 s/1 min to 10 min (switchable)	C200H-TM001
		Variable Resistor Connector	Connector w/lead wire (2 m) for 1 external resistor		C4K-CN223
	Standard B7A Interface Units		16 input pts	Connects to B7A Link Terminals.	C200H-B7AI1
			16 output pts		C200H-B7AO1

- Note**
1. If the Interrupt Input Unit is mounted on an Expansion I/O Rack, the interrupt function cannot be used and the Interrupt Input Unit will be treated as an ordinary 8-point Input Unit. Moreover, Interrupt Input Units cannot be used on Slave Racks. In addition, Interrupt Input Units require that a version 2 (i.e., model numbers with a "-V2" suffix) Backplane be used at the CPU Rack. If an earlier version Backplane is mounted, the interrupt function cannot be used.
 2. Transistor Output Unit C200H-OD212/OD21A and Contact Output Unit C200H-OC225 must be mounted to either a C200H-BC031-V1/V2, C200H-BC051-V1/V2, C200H-BC081-V1/V2, or C200H-BC101-V1/V2 Backplane.
 3. The C200H-OC225 might overheat if more than 8 outputs are turned ON simultaneously.

C200H Group-2 High-density I/O Units

Name	Specifications		Model number
DC Input Unit	64 pts	12 VDC	C200H-ID111
	32 pts	24 VDC	C200H-ID216
			C200H-ID218
	64 pts	24 VDC	C200H-ID217
			C200H-ID219
Transistor Output Unit	32 pts	16 mA 4.5 VDC to 100 mA 26.4 VDC	C200H-OD218
		0.5 A (5 A/Unit) 24 VDC	C200H-OD21B
	64 pts	16 mA 4.5 VDC to 100 mA 26.4 VDC	C200H-OD219

C200H Group-2 B7A Interface Units

Name	Specifications		Model number
Group-2 B7A Interface Units	32 input pts	Connects to B7A Link Terminals.	C200H-B7A12
	32 output pts		C200H-B7A02
	16 input pts and 16 output points		C200H-B7A21
	32 input pts and 32 output points		C200H-B7A22

C200H Special I/O Units

All of the following are classified as Special I/O Units except for the ASCII Unit, which is an Intelligent I/O Unit.

Name	Specifications		Model number	
High-density I/O Units	DC Input Unit	32 pts	5 VDC (TTL inputs); with high-speed input function	C200H-ID501
		32 pts	24 VDC; with high-speed inputs	C200H-ID215
	Transistor Output Unit	32 pts	0.1 A, 24 VDC (usable as 128-point dynamic output unit)	C200H-OD215
		32 pts	35 mA, 5 VDC (TTL outputs) (usable as 128-point dynamic output unit)	C200H-OD501
	DC Input/Transistor Output Unit	16 input/16 output pts	12-VDC inputs; with high-speed input function 0.1 A, 12-VDC outputs (usable as 128-point dynamic input unit)	C200H-MD115
		16 input/16 output pts	24-VDC inputs; with high-speed input function 0.1 A, 24-VDC outputs (usable as 128-point dynamic input unit)	C200H-MD215
		16 input/16 output pts	5 VDC (TTL inputs); with high speed input function 35 mA, 5 VDC Output (TTL outputs) (usable as 128-point dynamic input unit)	C200H-MD501

Name		Specifications	Model number
Analog I/O Units	Analog Input Unit	4 to 20 mA, 1 to 5/0 to 10 V (switchable); 4 inputs	C200H-AD001
		4 to 20 mA, 1 to 5/0 to 10/-10 to 10 V (switchable); 8 inputs	C200H-AD002
	Analog Output Unit	4 to 20 mA, 1 to 5/0 to 10 V (switchable); 2 outputs	C200H-DA001
		4 to 20 mA, -10 to 10 V; 4 outputs	C200H-DA002
Temperature Sensor Unit	Thermocouple (K(CA) or J(IC)) (switchable); 4 inputs		C200H-TS001
	Thermocouple (K(CA) or L(Fe-CuNi)) (switchable); 4 inputs		C200H-TS002
	Platinum resistance thermometer (JPt) (switchable), DIN standards; 4 inputs		C200H-TS101
	Platinum resistance thermometer (Pt) (switchable); 4 inputs		C200H-TS102
Temperature Control Unit	Thermocouple	Transistor output	C200H-TC001
		Voltage output	C200H-TC002
		Current output	C200H-TC003
	Pt resistance thermometer	Transistor output	C200H-TC101
		Voltage output	C200H-TC102
		Current output	C200H-TC103
Heat/Cool Temperature Control Unit	Thermocouple	Transistor output	C200H-TV001
		Voltage output	C200H-TV002
		Current output	C200H-TV003
	Pt resistance thermometer	Transistor output	C200H-TV101
		Voltage output	C200H-TV102
		Current output	C200H-TV103
PID Control Unit	Transistor output		C200H-PID01
	Voltage output		C200H-PID02
	Current output		C200H-PID03
Position Control Unit	1 axis	Pulse output; speeds: 1 to 99,990 pps	C200H-NC111
	1 axis	Directly connectable to servomotor driver; compatible with line driver; speeds: 1 to 250,000 pps	C200H-NC112
	2 axis	1 to 250000. pps. 53 pts per axis	C200H-NC211
Cam Positioner Unit	Detects angles of rotation by means of a resolver and provides ON and OFF outputs at specified angles. A maximum of 48 cam outputs (16 external outputs and 32 internal outputs) maximum are available.		C200H-CP114
High-speed Counter Unit	1 axis	Pulse input; counting speed: 50 kcps; 5 VDC/12 VDC/24 VDC	C200H-CT001-V1
	1 axis	Pulse input; counting speed: 75 kcps; RS-422 line driver	C200H-CT002
ASCII Unit	EEPROM		C200H-ASC02
Connecting Cable	For connecting the ASCII Unit to the FIT10 (9P/25P) Cable length: 2 m		CV500-CN228
I/D Sensor Unit	Local application, electromagnetic coupling		C200H-IDS01-V1
	Remote application, microwave transmissions		C200H-IDS21
	Read/Write Head	Electromagnetic type	V600-H series
		Microwave type	V620-H series
Data Carrier (see note)	SRAM type for V600-H series.	V600-D□□R□□	
	EEPROM type for V600-H series.	V600-D□□P□□	
Voice Unit	60 messages max.; message length: 32, 48, or 64 s (switchable)		C200H-OV001
	Connecting Cable	RS-232C	C200H-CN224

Name		Specifications	Model number
Fuzzy Logic Unit		Up to 8 inputs and 4 outputs. (I/O to and from specified data area words)	C200H-FZ001
	Fuzzy Support Software	Available on either 3.5" or 5.25" floppy disks.	C500-SU981-E

Note For Read/Write Head and Data Carrier combinations, refer to the *V600 FA ID System R/W Heads and EE-PROM Data Carriers Operation Manual and Supplement* or *V600 FA ID System R/W Heads and SRAM Data Carriers Operation Manual and Supplement*.

C200H Link Units

Name		Specifications		Model number
Host Link Unit	Rack-mounting	C200H only	APF/PCF	C200H-LK101-PV1
			RS-422	C200H-LK202-V1
			RS-232C	C200H-LK201-V1
PC Link Unit	Multilevel		RS-485	C200H-LK401
Remote I/O Master Unit	Up to two per PC; connectable to up to 5 Slaves per PC total		APF/PCF	C200H-RM001-PV1
			Wired	C200H-RM201

SYSMAC LINK Unit/SYSMAC NET Link Units

The SYSMAC LINK Units and SYSMAC NET Link Unit can only be used with the C200HS-CPU31-E and C200HS-CPU33-E CPUs.

Name		Specifications		Model number
SYSMAC LINK Unit	Wired via coaxial cable. Bus Connection Unit required separately. One C1000H-CE001 F Adapter included.	Data link capacity: 918 words		C200HW-SLK23
		Data link capacity: 2,966 words		C200HW-SLK24
	Wired via optical fiber cable. Bus Connection Unit required separately. An Optical Fiber Cable Bracket must be used to support an optical cable connected to the SYSMAC LINK Unit.	Data link capacity: 918 words		C200HW-SLK13
		Data link capacity: 2,966 words		C200HW-SLK14
Terminator	One required for each node at ends of System		C1000H-TER01	
Attachment Stirrup	Provided with SYSMAC LINK Unit		C200H-TL001	
F Adapter	---		C1000H-CE001	
F Adapter Cover	---		C1000H-COV01	
Communications Cable	Coaxial cables	Manufactured by Hitachi		ECXF5C-2V
		Manufactured by Fujigura		5C-2V
Auxiliary Power Supply Unit	Supplies backup power to either one or two SYSMAC LINK Units. One C200H-CN111 Power Connecting Cable included.		C200H-APS03	
SYSMAC NET Link Unit	Bus Connection Unit required separately. An Optical Fiber Cable Bracket must be used to support an optical cable connected to the SYSMAC NET Link Unit.		C200HS-SNT32	
Power Supply Adapter	Required when supplying power from Central Power Supply	For 1 Unit		C200H-APS01
		For 2 Units		C200H-APS02
Power Cable	Connects Power Supply Adapter and SYSMAC NET Link Unit	For 1 Unit		C200H-CN111
		For 2 Units		C200H-CN211

Name	Specifications	Model number
Bus Connection Unit	Connects SYSMAC LINK Unit or SYSMAC NET Link Unit to C200HS-CPU31-E/CPU33-E	For 1 Unit
		For 2 Units
		C200H-CE001
		C200H-CE002

CompoBus Units

Name	Specifications	Model number
CompoBus/S Master Unit	---	C200HW-SRM21
CompoBus/D (DeviceNet) Master Unit	---	C200HW-DRM21

Optional Products

Name	Specifications	Model number
I/O Unit Cover	Cover for 10-pin terminal block	C200H-COV11
Terminal Block Cover	Short protection for 10-pin terminal block	C200H-COV02
	Short protection for 19-pin terminal block	C200H-COV03
Connector Cover	Protective cover for unused Backplane connectors	C500-COV01
Space Unit	Used for vacant slots	C200H-SP001
Battery Set	For C200H RAM Memory Unit only	C200H-BAT09
Relay	24 VDC	G6B-1174P-FD-US DC24
		G6R-1
Backplane Insulation Plate	For 10-slot Backplane	C200H-ATTA1
	For 8-slot Backplane	C200H-ATT81
	For 5-slot Backplane	C200H-ATT51
	For 3-slot Backplane	C200H-ATT31
I/O Bracket	For 10-slot Backplane	C200H-ATTA3
	For 8-slot Backplane	C200H-ATT83
	For 5-slot Backplane	C200H-ATT53
	For 3-slot Backplane	C200H-ATT33

- Note**
1. When ordering, specify the model name (any component of which is not sold separately).
 2. Order the press-fit tool from the manufacturer.

Mounting Rails and Accessories

Name	Specifications	Model number
DIN Track Mounting Bracket	1 set (2 included)	C200H-DIN01
DIN Track	Length: 50 cm; height: 7.3 mm	PFP-50N
	Length: 1 m; height: 7.3 mm	PFP-100N
	Length: 1 m; height: 16 mm	PFP-100N2
End Plate	---	PFP-M
Spacer	---	PFP-S

Link Adapters

Name	Specifications	Model number
Link Adapter	3 RS-422 connectors	3G2A9-AL001
	3 optical connectors (APF/PCF)	3G2A9-AL002-PE
	3 optical connectors (PCF)	3G2A9-AL002-E
	1 connector each for APF/PCF, RS-422, and RS-232C	3G2A9-AL004-PE
	1 connector each for PCF, RS-422, and RS-232C	3G2A9-AL004-E
	1 connector each for APF/PCF and APF	3G2A9-AL005-PE
	1 connector each for PCF and AGF	3G2A9-AL005-E
	1 connector for APF/PCF; 2 for AGF	3G2A9-AL006-PE
	O/E converter; 1 connector for RS-485, 1 connector each for APF/PCF	B500-AL007-PE
	Used for on-line removal of SYSMAC NET Link Units from the SYSMAC NET Link System, SYSMAC NET Optical Link Adapter 3 connectors for APF/PCF.	B700-AL001

SYSMAC BUS/SYSMAC WAY Optical Fiber Products

Plastic Clad Optical Fiber Cable/All Plastic Optical Fiber Cable

Name	Specifications	Model number	
Plastic Clad Optical Fiber Cable (indoor)	0.1 m, w/connectors	Ambient temp: -10° to 70°C	3G5A2-OF011
	1 m, w/connectors		3G5A2-OF101
	2 m, w/connectors		3G5A2-OF201
	3 m, w/connectors		3G5A2-OF301
	5 m, w/connectors		3G5A2-OF501
	10 m, w/connectors		3G5A2-OF111
	20 m, w/connectors		3G5A2-OF211
	30 m, w/connectors		3G5A2-OF311
	40 m, w/connectors		3G5A2-OF411
	50 m, w/connectors		3G5A2-OF511
	Cable only; order desired length between 1 and 200 m in increments of 1 m.		B500-OF002
All Plastic Optical Fiber Cable	Cable only; order desired length in 5 m increments between 5 and 100 m, or in increments of 200 m or 500 m.	B500-PF002	
Optical Connectors A	Two optical connectors (brown) for APF (10 m max.)	3G5A2-CO001	
Optical Connectors B	Two optical connectors (black) for APF (8 to 20 m)	3G5A2-CO002	
All Plastic Optical Fiber Cable Set	1-m cable with an Optical Connector A connected to each end	3G5A2-PF101	
Optical Fiber Processing Kit	Accessory: 125-mm nipper (Muromoto Tekko's 550M) for APF	3G2A9-TL101	

H-PCF

Name	Specifications	Model number		
Optical Fiber Cable SYSMAC BUS, SYSMAC WAY	10 m, black	Two-core cable	S3200-HCCB101	
	50 m, black		S3200-HCCB501	
	100 m, black		S3200-HCCB102	
	500 m, black		S3200-HCCB502	
	1000 m, black		S3200-HCCB103	
	10 m, orange		S3200-HCCO101	
	50 m, orange		S3200-HCCO501	
	100 m, orange		S3200-HCCO102	
	500 m, orange		S3200-HCCO502	
	1000 m, orange		S3200-HCCO103	
	10 m, black		Two-core cable	S3200-HBCB101
	50 m, black			S3200-HBCB501
	100 m, black			S3200-HBCB102
	500 m, black			S3200-HBCB502
1000 m, black	S3200-HBCB103			
Optical Fiber Cable Connector	SYSMAC BUS: C200H-RM001-PV1 C200H-RT001/RT002-P C500-RM001-(P)V1 C500-RT001/RT002-(P)V1 B500-□□□(-P)	Half-lock connector for Remote I/O Master, Remote I/O Slave, Host Link Unit, and Link Adapter	S3200-COCH82	

- Note**
- Optical fiber cables must be prepared and connected by specialists.
 - If the user prepares and connects optical fiber cables, the user must take a seminar held under the auspices of Sumitomo Electric Industries, Ltd. and obtain a proper certificate.
 - The Optical Power Tester, Head Unit, Master Fiber Set, and Optical Fiber Assembling Tool are required to connect optical fiber cables.

Optical Fiber Assembling Tool

Name	Specifications	Model number
Optical Fiber Assembling Tool	Used to connect H-PCF and crimp-cut connectors for optical transmission systems such as the SYSMAC C- and CV-series SYSMAC BUS, SYSMAC LINK and SYSMAC NET.	S3200-CAK1062

- Note**
- Optical fiber cables must be prepared and connected by specialists.
 - The Optical Power Tester, Head Unit, Master Fiber set, and Optical Fiber Assembling Tool are required to connect optical fiber cables.

Optical Power Tester

Name	Specifications	Head Unit	Model number
Optical Power Tester (see note) (provided with a connector adapter, light source unit, small single-head plug, hard case, and AC adapter)	SYSMAC BUS: C200H-RM001-PV1 C200H-RT001/RT002-P C500-RM001-(P)V1 C500-RT001/RT002-(P)V1	S3200-CAT2822 (provided with the Tester)	S3200-CAT2820

- Note:** There is no difference between the light source unit and connector adapter for the Head Unit and those for the Optical Power Tester.

Head Unit

Name	Specifications	Model number
Head Unit (a set consisting of light source unit and connector adapter) (see note)	SYSMAC BUS: C200H-RM001-PV1 C200H-RT001/RT002-P	S3200-CAT2822
	SYSMAC NET: S3200-LSU03-V1/LSU03-01E C500-SNT31-V4 3G8FX-TM111 3G8SX-TM111	S3200-CAT3202

Note: Use a proper Head Unit model for the optical module to be used. If two types of optical modules (unit type and board type) are used, order an Optical Power Tester plus a proper Head Unit model.

Master Fiber Set

Name	Specifications	Model number
Master Fiber Set (1 m)	S3200-CAT3202 (SYSMAC NET, NSB, NSU, Bridge)	S3200-CAT3201
	S3200-CAT2002/CAT2702 (SYSMAC NET, SYSMAC LINK)	S3200-CAT2001H
	S3200-CAT2822 (SYSMAC BUS)	S3200-CAT2821

- Note**
1. The Master Fiber Set is used in combination with the Optical Power Tester to check the optical levels of optical fiber cables connected to optical fiber cable connectors.
 2. Optical fiber cables must be prepared and connected by specialists.
 3. The Optical Power Tester, Head Unit, Master Fiber set, and Optical Fiber Assembling Tool are required to connect optical fiber cables.

SYSMAC LINK/SYSMAC NET Link Optical Fiber Products

Optical Fiber Cables for SYSMAC LINK and SYSMAC NET Link Systems

Use hard-plastic-clad quartz optical fiber (H-PCF) cables for SYSMAC LINK and SYSMAC NET Link Systems. H-PCF cables are available with connectors already attached, or cables and connectors can be purchased separately and assembled by the user. Refer to the *System Manual* for the SYSMAC LINK or SYSMAC NET Link Systems for assembly procedures. Models numbers for H-PCF cables with connectors attached are provided in the following illustration.

Model Numbers for H-PCF Cables with Connectors

S3200-CN□□□-□□-□□

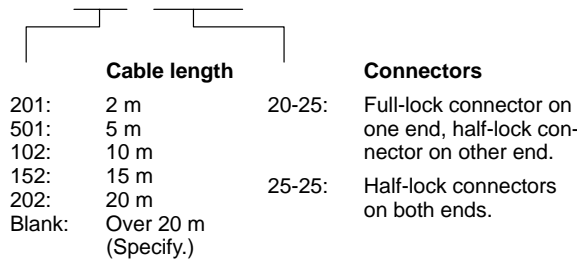

An Optical Fiber Cable Bracket must be used to support an optical fiber cable connected to the C200HS-SNT32 SYSMAC NET Link Unit or C200HW-SLK13/SLK14 SYSMAC LINK Unit.

User optical fiber cables with both tension members and power supply lines.

The following half-lock connector is used and connects to the C200HS SYSMAC LINK and SYSMAC NET Link Units: S3200-COCF2511.

The following full-lock connector is used and connects to the CV500 SYSMAC LINK and SYSMAC NET Link Units and the C1000H SYSMAC LINK Unit: S3200-COCF2011. This full-lock connector cannot be connected to the C200HS SYSMAC LINK and SYSMAC NET Link Units.

The above connectors cannot be used for the C500 SYSMAC NET Link Unit, cable relays, and the SYSMAC NET Link Network Service Board. Refer to the *SYSMAC NET Link System Manual* for further information.

Programming Devices

Name	Specifications	Model number	
Programming Console	Hand-held, w/backlight; requires the C200H-CN222 or C200H-CN422, see below	C200H-PR027-E	
	2-m Connecting Cable attached.	CQM1-PRO01-E	
Programming Console Mounting Bracket	Used to attach Hand-held Programming Console to a panel.	C200H-ATT01	
Programming Console Connecting Cables	For Hand-held Programming Console	2 m	C200H-CN222
		4 m	C200H-CN422
	Provided with an anti-static cover and conforms to EC directives.	2 m	C200HS-CN222
		4 m	C200HS-CN422
Data Setting Console	Used for data input and process value display for the C200H-TC□□□, C200H-TV□□□, C200H-CP114, and C200H-PID0□.	C200H-DSC01	
Data Setting Console Connecting Cables	For C200H-DSC01	2 m	C200H-CN225
		4 m	C200H-CN425
Connecting Cable	Used to connect an IBM PC/AT or compatible to the C200HS.	3.3 m	CQM1-CIF02

Ladder Support Software (LSS)

Name	Specifications	Model number
Ladder Support Software (for C20, C□□P, C□□K, C120, C□□H, C200H, C200HS, C500, C1000H, C2000H, and CQM1)	5.25", 2D for IBM PC/AT compatible	C500-SF711-EV3
	3.5", 2HD for IBM PC/AT compatible	C500-SF312-EV3

SYSMAC Support Software (SSS)

Product	Description	Model no.
SYSMAC Support Software	3.5", 2HD for IBM PC/AT compatible	C500-ZL3AT1-E

Training Materials

Name	Specifications	Model number
SYSMAC Training System	Includes text book, cassette tape, and input switch board.	C200H-ETL01-E
Fuzzy Training System	Includes a Fuzzy Training System Manual, a Main Unit, a C200H-MR831 Memory Unit, a C200H-PRO27-E Programming Console, a C200H-CN222 Cable for the Programming Console, C500-SU381-E Fuzzy Training Software, an RS-232C Cable, and a carrying belt.	C200H-ETL13-E

Appendix B Specifications

The following figures and tables provide specifications for each Unit of the C200HS. I/O Units may take on one of three different shapes and are sometimes referred to as A-shape Units, B-shape Units, or E-shape Units. Group-2 High-density I/O Units take on one of two different shapes and are sometimes referred to as C-shape Units or D-shape Units. Refer to the figures at the end of the I/O Unit specifications for the exact dimensions of these five shapes of I/O Unit.

CPU's and Power Supplies

General Specifications

Item	C200HS-CPU01-E/CPU01-EC/CPU21-E/ CPU21-EC/CPU31-E, C200H-PS221/PS221-C	C200HS-CPU03-E/CPU23-E/ CPU33-E, C200H-PS211
Supply Voltage	100 to 120/200 to 240 VAC selectable 50/60 Hz	24 VDC
Operating Voltage Range	85 to 132/170 to 264 VAC	20.4 to 26.4 VDC
Power Consumption	120 VA max.	40 W max.
Surge Current	30 A max.	30 A max.
Output Capacity	CPU01-E/CPU01-EC/CPU21-E/CPU21-EC/CPU31-E: 4.6 A, 5 VDC (3.9 A supplied to I/O Units) CPU03-E/CPU23-E/CPU33-E: 3 A, 5 VDC (2.3 A supplied to I/O Units) Expansion I/O Rack: 3 A, 5 VDC (2.7 A supplied to I/O Units)	
Fuse	2 A 250 V 5.2 dia. x 20 (MF51NR)	2 A 125 V 5.2 dia. x 20 (MF51NR)
24 VDC Output	0.3 A, 24 VDC $+10\%/_{-20\%}$	None
Insulation Resistance	20 M Ω between AC terminals and the GR terminal at 500 VDC (See note 1.)	(See note 2.)
Dielectric Strength	2,300 VAC at 50/60 Hz for 1 minute between AC terminals and housing; 1,000 VAC at 50/60 Hz for 1 minute between DC terminals and housing. Leakage current: 10 mA max. (See note 1.)	(See note 2.)
Noise Immunity	1,500 Vp-p, pulse width: 100 ns to 1 μ s, rise time: 1 ns pulse (by noise simulator)	
Vibration	JIS C0911 conforming, 10 to 57 Hz; 0.075 mm amplitude, 57 to 150 Hz; acceleration: 9.8 m/s ² (see note 3), in X, Y, and Z directions, for 80 minutes each (sweep time 8 min x 10 sweeps = 80 min); (When mounted on DIN track, 2 to 55 Hz, 2.94 m/s ² , in X, Y, and Z directions, for 20 minutes each)	
Shock	JIS C0912 conforming, 147 m/s ² in X, Y, and Z directions, 3 times each	
Ambient Temperature	Operating: 0° to 55°C; storage: -20° to 75°C (without battery)	
Humidity	10% to 90% (without condensation)	
Atmosphere	Must be free of the following: <ul style="list-style-type: none"> • Corrosive gases • Abrupt temperature changes • Direct sunlight • Dust, salt, or metal filings • Water, oil, or chemicals 	
Grounding	Connect to a ground of 100 Ω or less	
Enclosure Rating	Mounted in a panel	
Weight	6 kg max.	

- Note**
- Internal components might be damaged if insulation resistance or dielectric strength tests are conducted with the LG and GR terminals connected.
 - Do not conduct a dielectric strength test on the C200HS-CPU03-E/CPU23-E/CPU33-E, PS211, RT002-P, or RT202 Units. The power supply input line and internal circuit of the 24 VDC Power Supply

are not isolated from each other. If a dielectric strength test is conducted at 50 VDC or higher, internal components such as capacitors will be damaged. If a short-circuit test must be conducted, use a device such as a tester.

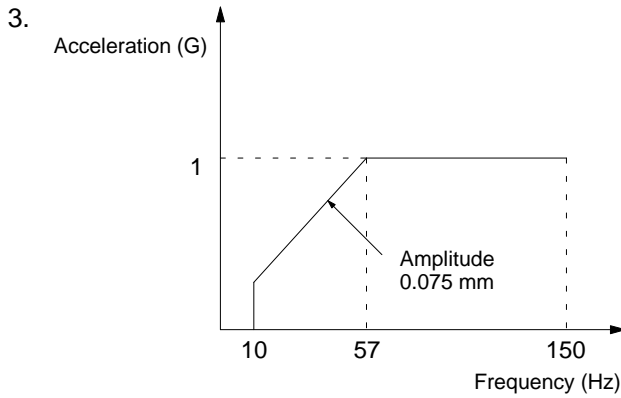

C200HS Dimensions

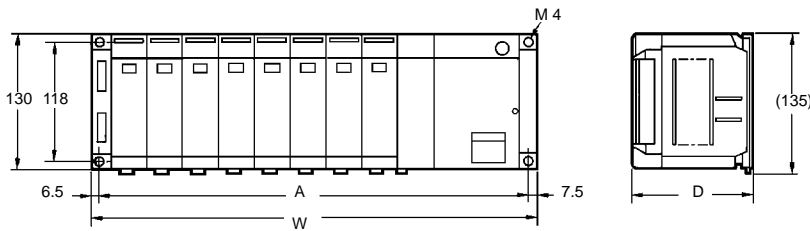

Backplane	A	W	D	
			CPU01-E/CPU01-EC/ CPU03-E	CPU21-E/CPU21-EC/ CPU23-E/CPU31-E/ CPU33-E
C200H-BC031-V2	246	260	118	143
C200H-BC051-V2	316	330		
C200H-BC081-V2	421	435		
C200H-BC101-V2	491	505		

- Note**
1. All units are in millimeters.
 2. For dimensions of individual units and Backplane, refer to page 193 onward.

CPU Specifications

Control Method	Stored program				
I/O Control Method	Cyclic scan and immediate processing are both possible.				
Programming Method	Ladder diagram				
Instruction Length	1 address/instruction, 1 to 4 words/instruction				
Number of Instructions	CPU01-E/01-EC/03-E/21-E/23-E: 225 (14 basic instructions + 211 special instructions) CPU31-E/33-E: 229 (14 basic instructions + 215 special instructions)				
Execution Time	Basic instructions: 0.375 to 1.313 μ s Special instructions: Approx. 10 μ s				
Program Capacity	15.2K words max.				
IR Area: I/O bits	480 bits (00000 through 02915)	I/O bits for Group-2 High-density Units and Group-2 B7A Interface Units: 320 bits (03000 through 04915)	I/O bits for I/O Units mounted to Slave Racks: 800 bits (05000 through 09915)	I/O bits for Special I/O Units: 1,600 bits (10000 through 19915)	I/O bits for Optical I/O Units: 512 bits (20000 through 23115)
IR Area: Work bits	6,688 bits (03000 through 23515, 30000 through 51115)				
SR bits	1,016 (23600 through 25507 and 25600 through 29915)				
TR bits	8 (TR 0 through 7)				
HR bits	1,600 (HR 0000 through 9915)				
AR bits	448 (AR 0000 through 2715)				
LR bits	1,024 (LR 0000 through 6315)				
Timers/Counters	512 (TIM/CNT 000 through 511) TIMHs: 0 through 99.99 s		TIMs: 0 through 999.9 s CNT: 0 through 9999 counts		
DM words	Read/write: 6,144 (DM 0000 through 6143) Read only: 512 (DM 6144 through 6655) 3,000 words max. (DM 7000 through 9999)				
RUN Output	Contacts are closed while PC is in RUN mode and operating. Max. switching capacity: 2A 250 VAC (resistive load) 0.5 A 250 VAC (inductive load, $\cos\phi = 0.4$) 2 A 24 VDC				
Power Failure Backup Function	Holds HR, AR, CNT, and DM, and clock (RTC) contents.				
Clock Function	Standard				
Memory Backup Time	The battery service life is five years at 25°C. The service life will be shortened if the battery is used at higher temperatures. Replace the battery within one week after the battery alarm indicator starts blinking. When replacing the battery, install the new battery within five minutes after removing the old one.				
Self-diagnostic Function	CPU errors (watchdog timer), I/O verification errors, host link errors, memory errors, battery errors, I/O bus errors, remote I/O errors, etc.				
Program Check Function	Carries out program checks at the beginning of operation for items such as no END instruction, instruction errors, and so on.				

Standard I/O Units

AC Input Unit C200H-IA121

Rated Input Voltage	100 to 120 VAC 50/60 Hz
Operating Input Voltage	85 to 132 VAC 50/60 Hz
Input Impedance	9.7 kΩ (50 Hz), 8 kΩ (60 Hz)
Input Current	10 mA typical (at 100 VAC)
ON Voltage	60 VAC min.
OFF Voltage	20 VAC max.
ON Response Time	35 ms max. (at 100 VAC, 25°C)
OFF Response Time	55 ms max. (at 100 VAC, 25°C)
No. of Circuits	1 (8 points/common)
Internal Current Consumption	10 mA 5 VDC max.
Weight	250 g max.
Dimensions	A-shape

Circuit Configuration

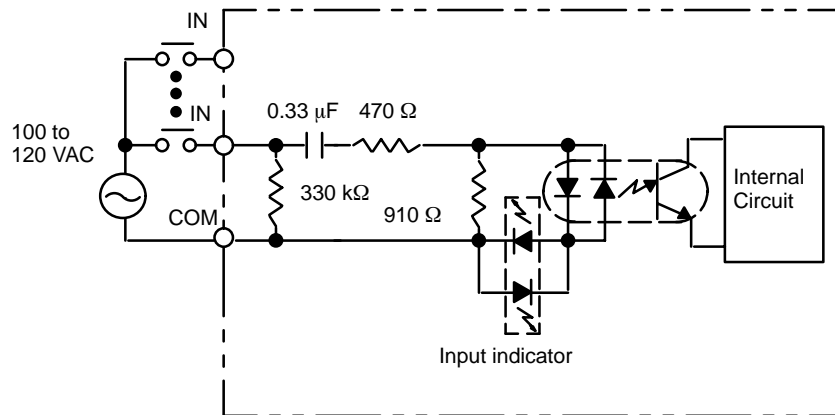

Terminal Connections

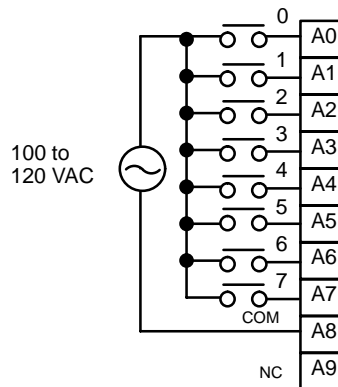

AC Input Unit C200H-IA122/IA122V

Rated Input Voltage	100 to 120 VAC 50/60 Hz
Operating Input Voltage	85 to 132 VAC 50/60 Hz
Input Impedance	9.7 kΩ (50 Hz), 8 kΩ (60 Hz)
Input Current	10 mA typical (at 100 VAC)
ON Voltage	60 VAC min.
OFF Voltage	20 VAC max.
ON Response Time	35 ms max. (at 100 VAC, 25°C)
OFF Response Time	55 ms max. (at 100 VAC, 25°C)
No. of Circuits	1 (16 points/common)
Internal Current Consumption	10 mA 5 VDC max.
Weight	300 g max./400 g max. (IA122V)
Dimensions	B-shape

Circuit Configuration

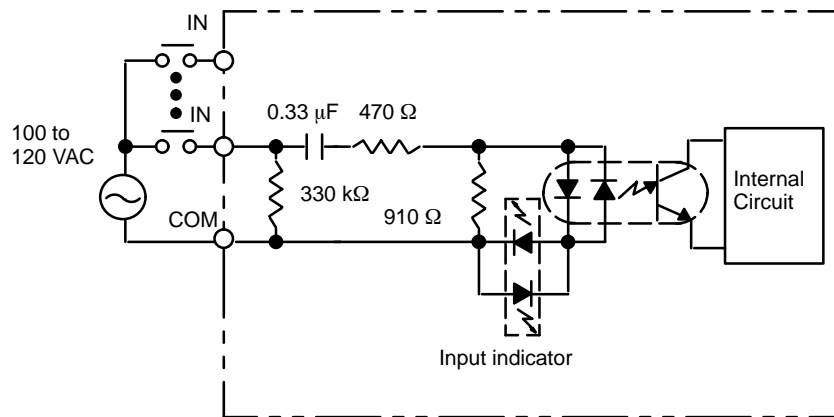

Terminal Connections

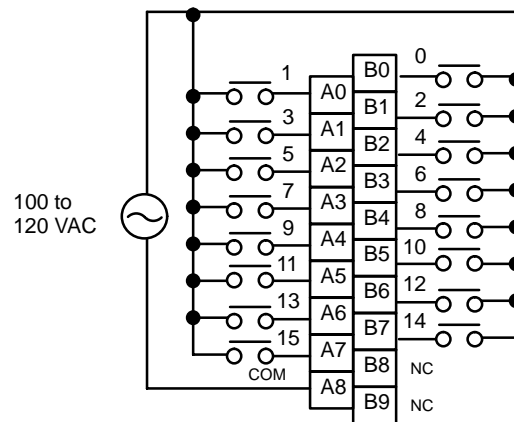

AC Input Unit C200H-IA221

Rated Input Voltage	200 to 240 VAC 50/60 Hz
Operating Input Voltage	170 to 264 VAC 50/60 Hz
Input Impedance	21 kΩ (50 Hz), 18 kΩ (60 Hz)
Input Current	10 mA typical (at 200 VAC)
ON Voltage	120 VAC min.
OFF Voltage	40 VAC max.
ON Response Time	35 ms max. (at 200 VAC, 25°C)
OFF Response Time	55 ms max. (at 200 VAC, 25°C)
No. of Circuits	1 (8 points/common)
Internal Current Consumption	10 mA 5 VDC max.
Weight	250 g max.
Dimensions	A-shape

Circuit Configuration

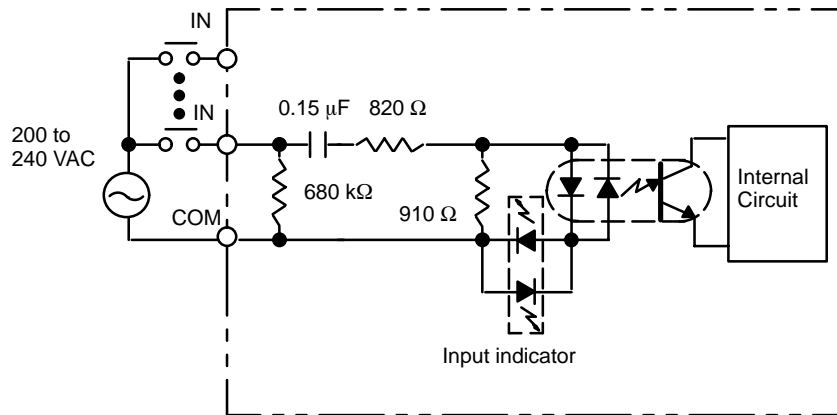

Terminal Connections

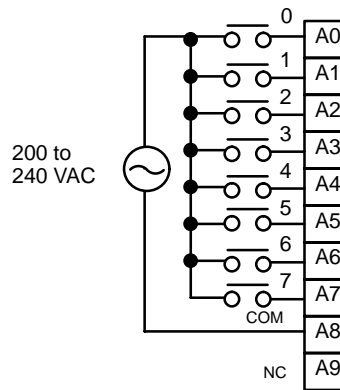

AC Input Unit C200H-IA222/IA222V

Rated Input Voltage	200 to 240 VAC 50/60 Hz
Operating Input Voltage	170 to 264 VAC 50/60 Hz
Input Impedance	21 kΩ (50 Hz), 18 kΩ (60 Hz)
Input Current	10 mA typical (at 200 VAC)
ON Voltage	120 VAC min.
OFF Voltage	40 VAC max.
ON Response Time	35 ms max. (at 200 VAC, 25°C)
OFF Response Time	55 ms max. (at 200 VAC, 25°C)
No. of Circuits	1 (16 points/common)
Internal Current Consumption	10 mA 5 VDC max.
Weight	300 g max./400 g max. (IA222V)
Dimensions	B-shape

Circuit Configuration

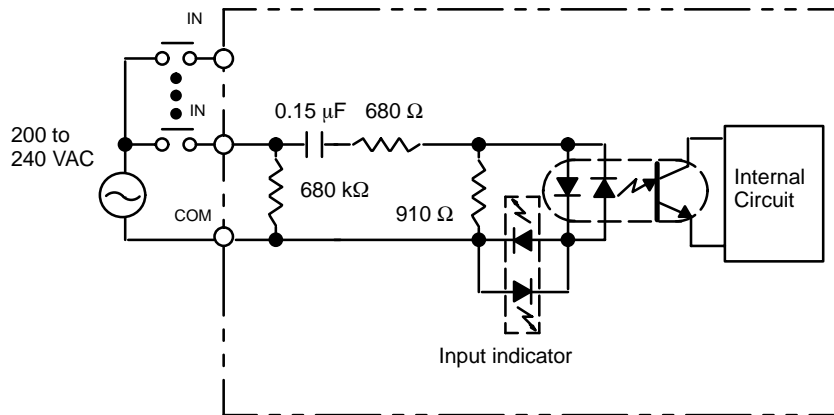

Terminal Connections

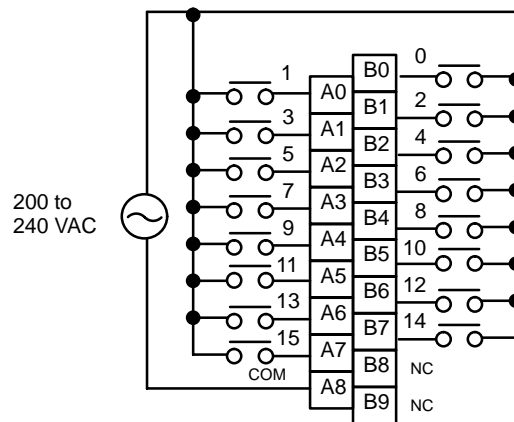

No-Voltage Contact Input Unit C200H-ID001

Input Voltage	No-voltage contact/NPN output type (negative common)
Input Impedance	3 kΩ
Input Current	7 mA typical
ON Voltage	(14.4 VDC min.)
OFF Voltage	(5.0 VDC max.)
ON Response Time	1.5 ms max. (no-voltage contact, at 25°C)
OFF Response Time	1.5 ms max. (no-voltage contact, at 25°C)
No. of Circuits	1 (8 points/common)
Internal Current Consumption	10 mA 5 VDC max.
Weight	200 g max.
Dimensions	A-shape

Circuit Configuration

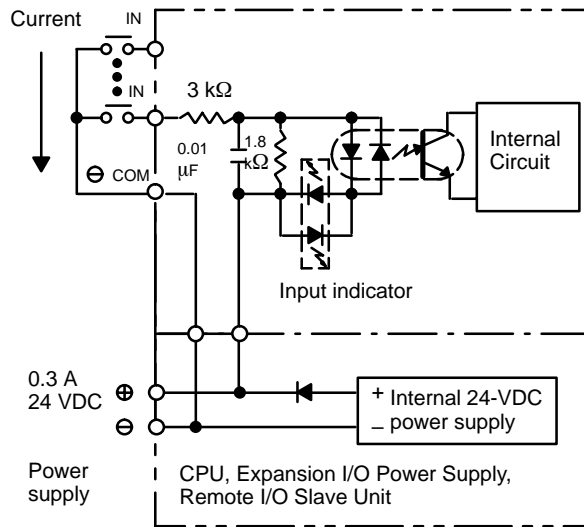

Note The power is supplied to the Input Units from the 24 VDC output of the Power Supply of the CPU, Expansion I/O Unit, or Remote I/O Unit. Never connect 24 VDC output terminals to the input terminals or COM terminals.

Terminal Connections

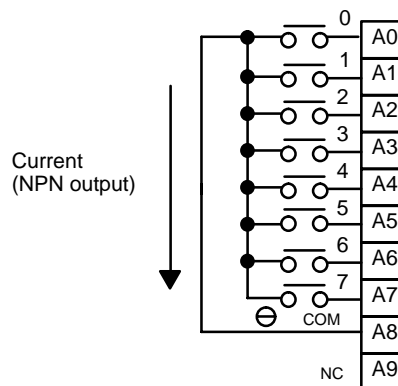

No-Voltage Contact Input Unit C200H-ID002

Input Voltage	No-voltage contact/PNP output type (positive common)
Input Impedance	3 kΩ
Input Current	7 mA typical
ON Voltage	(14.4 VDC min.)
OFF Voltage	(5.0 VDC max.)
ON Response Time	1.5 ms max. (no-voltage contact, at 25°C)
OFF Response Time	1.5 ms max. (no-voltage contact, at 25°C)
No. of Circuits	1 (8 points/common)
Internal Current Consumption	10 mA 5 VDC max.
Weight	200 g max.
Dimensions	A-shape

Circuit Configuration

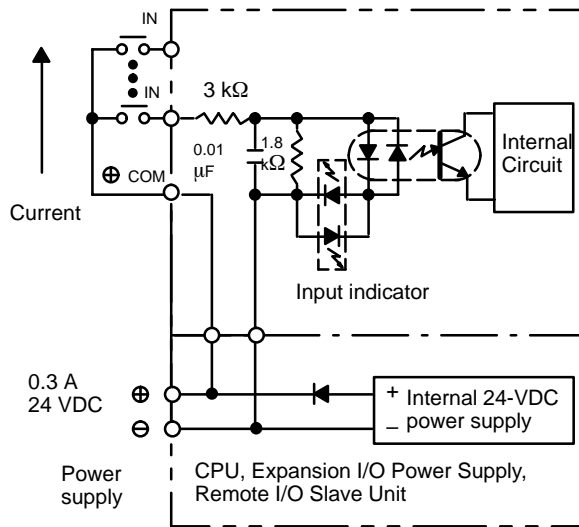

Note The power is supplied to the Input Units from the 24 VDC output of the Power Supply of the CPU, Expansion I/O Unit, or Remote I/O Unit. Never connect 24 VDC output terminals to the input terminals or COM terminals.

Terminal Connections

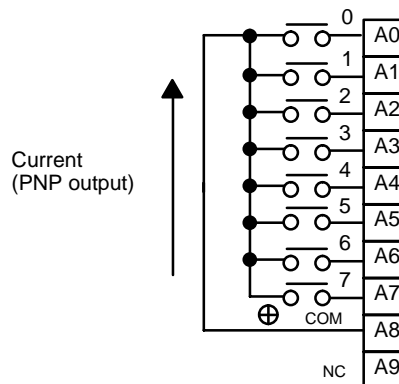

DC Input Unit C200H-ID211

Rated Input Voltage	12 to 24 VDC
Operating Input Voltage	10.2 to 26.4 VDC
Input Impedance	2 k Ω
Input Current	10 mA (at 24 VDC)
ON Voltage	10.2 VDC min.
OFF Voltage	3.0 VDC max.
ON Response Time	1.5 ms max. (at 24 VDC, 25°C)
OFF Response Time	1.5 ms max. (at 24 VDC, 25°C)
No. of Circuits	1 (8 point/common)
Internal Current Consumption	10 mA 5 VDC max.
Weight	200 g max.
Dimensions	A-shape

Circuit Configuration

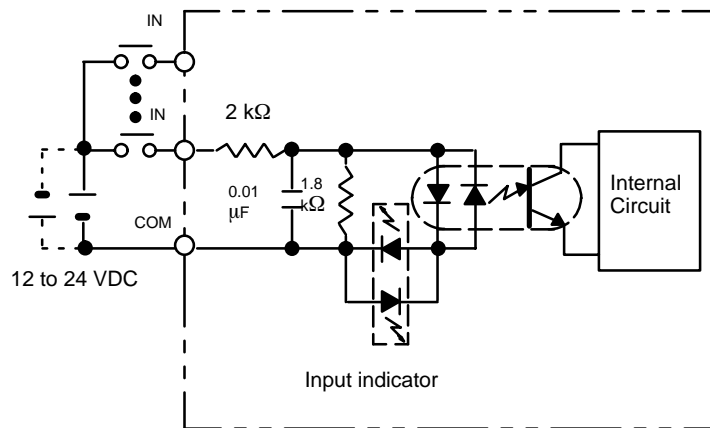

Terminal Connections

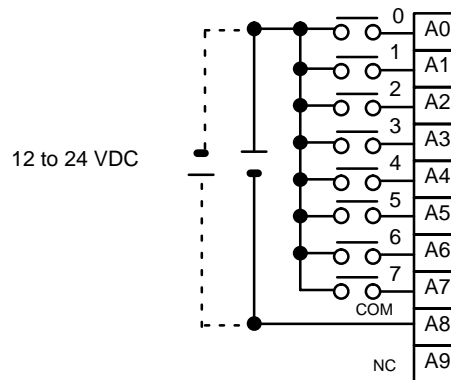

DC Input Unit C200H-ID212

Rated Input Voltage	24 VDC
Operating Input Voltage	20.4 to 26.4 VDC
Input Impedance	3 kΩ
Input Current	7 mA (at 24 VDC)
ON Voltage	14.4 VDC min.
OFF Voltage	5.0 VDC max.
ON Response Time	1.5 ms max. (at 24 VDC, 25°C)
OFF Response Time	1.5 ms max. (at 24 VDC, 25°C)
No. of Circuits	1 (16 points/common)
Internal Current Consumption	10 mA 5 VDC max.
Weight	300 g max.
Dimensions	B-shape

Circuit Configuration

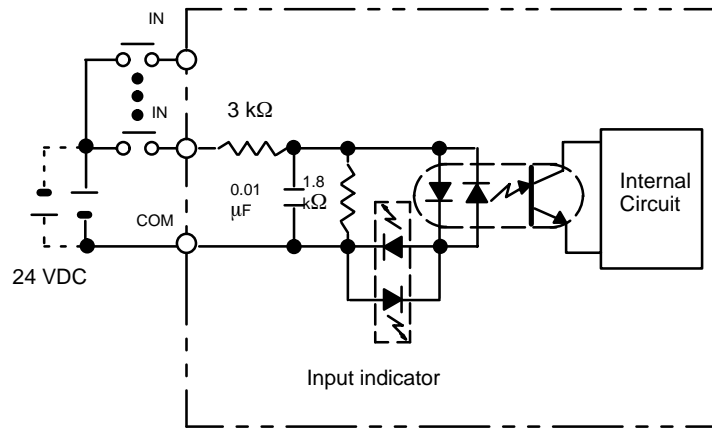

Terminal Connections

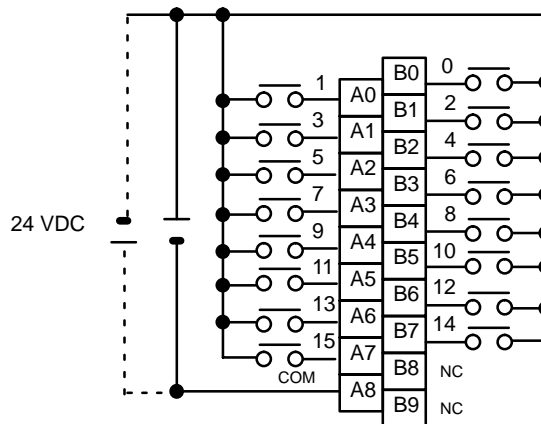

AC/DC Input Unit C200H-IM211

Rated Input Voltage	12 to 24 VDC
Operating Input Voltage	10.2 to 26.4 VDC
Input Impedance	2 kΩ
Input Current	10 mA typical (at 24 VDC)
ON Voltage	10.2 VDC min.
OFF Voltage	3.0 VDC max.
ON Response Time	15 ms max. (at 24 VDC, 25°C)
OFF Response Time	15 ms max. (at 24 VDC, 25°C)
No. of Circuits	1 (8 points/common)
Internal Current Consumption	10 mA 5 VDC max.
Weight	200 g max.
Dimensions	A-shape

Circuit Configuration

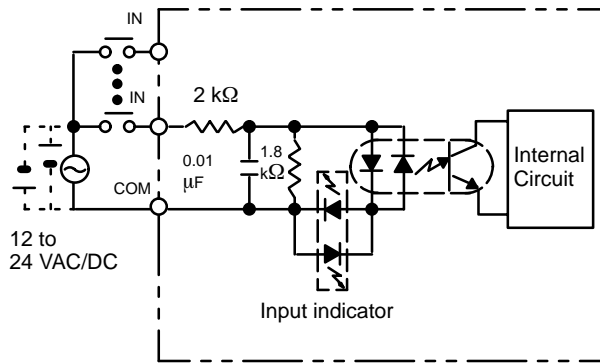

Terminal Connections

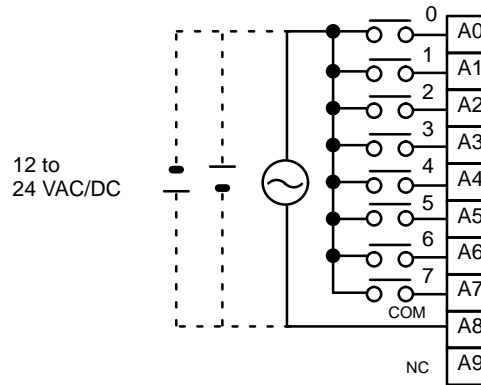

AC/DC Input Unit C200H-IM212

Rated Input Voltage	24 VDC
Operating Input Voltage	20.4 to 26.4 VDC
Input Impedance	3 kΩ
Input Current	7 mA typical (at 24 VDC)
ON Voltage	14.4 VDC min.
OFF Voltage	5.0 VDC max.
ON Response Time	15 ms max. (at 24 VDC, 25°C)
OFF Response Time	15 ms max. (at 24 VDC, 25°C)
No. of Circuits	1 (16 points/common)
Internal Current Consumption	10 mA 5 VDC max.
Weight	250 g max.
Dimensions	B-shape

Circuit Configuration

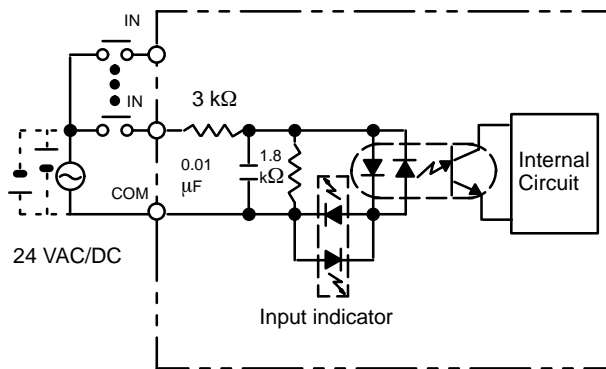

Terminal Connections

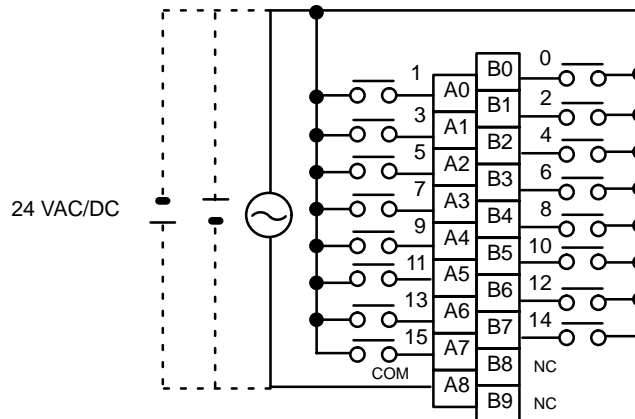

Triac Output Unit C200H-OA121-E

Max. switching capacity	1 A 120 VAC, 50/60 Hz (4 A/Unit)
Min. switching capacity	10 mA (resistive load)/40 mA (inductive load) 10 VAC
Leakage Current	3 mA (100 VAC) max.
Residual Voltage	1.2 V max.
ON Response Time	1 ms max.
OFF Response Time	1/2 of load frequency or less.
No. of Circuits	1 (8 points/common)
Internal Current Consumption	140 mA 5 VDC max.
Fuse Rating	5 A 125 V (5.2-dia.x20)
Power for External Supply	N/A
Weight	250 g max.
Dimensions	A-shape

Circuit Configuration

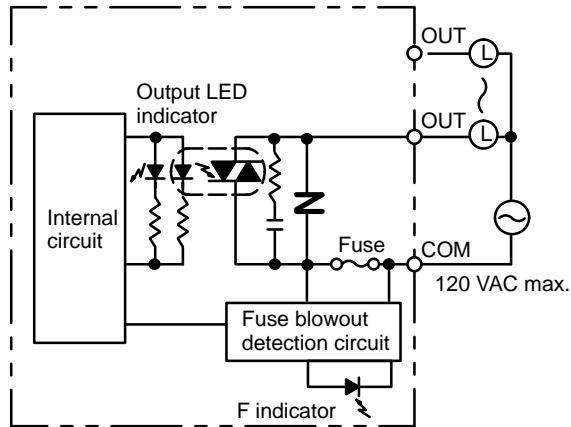

Fuse: 5 A 125 V (5.2-dia.x20) GGS (Nagasawa)

Note When the fuse blows, F indicator lights and bit 08 turns ON. Bits 08 through 15 cannot be used as IR bits.

Terminal Connections

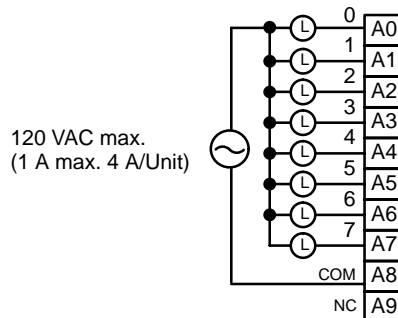

Triac Output Unit C200H-OA122-E

Max. Switching Capacity	1.2 A 120 VAC, 50/60 Hz (4 A/Unit)
Max. Inrush Current	15 A (pulse width: 100 ms) 30 A (pulse width: 10 ms)
Min. Switching Capacity	100 mA 10 VAC/50 mA 24 VAC/10 mA 100 VAC min.
Leakage Current	1.5 mA (120 VAC) max.
Residual Voltage	1.5 VAC max. (50 to 1,200 mA)/ 5 VAC max. (10 to 50 mA)
ON Response Time	1 ms max.
OFF Response Time	1/2 of load frequency+1 ms or less.
No. of Circuits	1 (8 points/common)
Internal Current Consumption	180 mA 5 VDC max.
Fuse Rating	5 A 125 V (5.2-dia.x20)
Power for External Supply	N/A
Weight	300 g max.
Dimensions	E-shape

Circuit Configuration

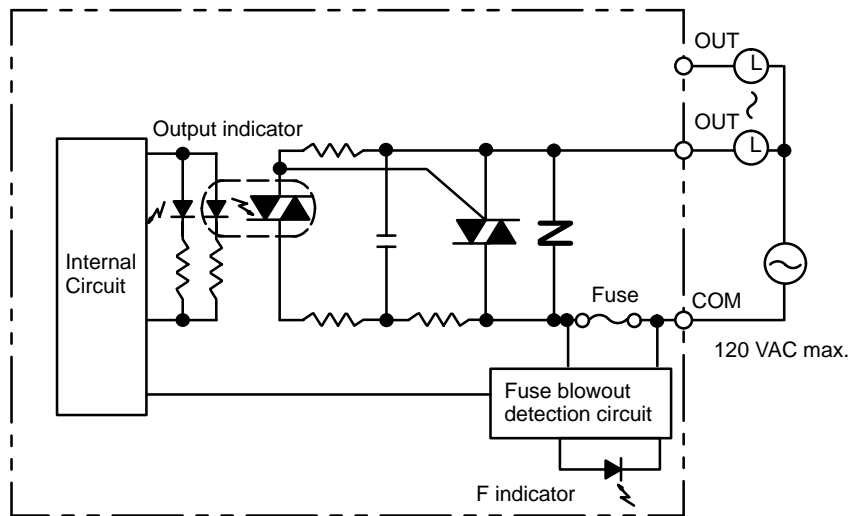

Fuse: 5 A 125 V (5.2-dia.x20) GGS (Nagasawa)

Note When the fuse blows, the F indicator lights and bit 08 turns ON. Bits 08 through 15 cannot be used as IR bits.

Terminal Connections

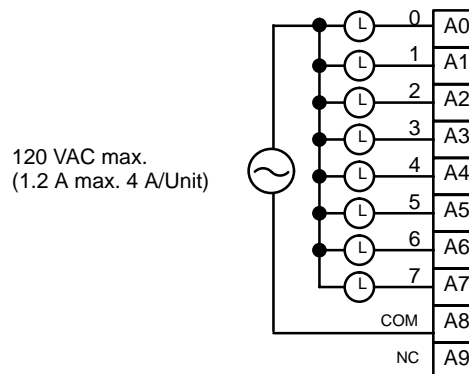

Triac Output Unit C200H-OA222V

Max. Switching Capacity	0.3 A 250 VAC, 50/60 Hz (2 A/Unit)
Min. Switching Capacity	10 mA (resistive load)/40 mA (inductive load) 10 VAC
Leakage Current	3 mA (100 VAC) max./6 mA (200 VAC) max.
Residual Voltage	1.2 V max.
ON Response Time	1/2 of load frequency or less.
OFF Response Time	1/2 of load frequency or less.
No. of Circuits	1 (12 points/common)
Internal Current Consumption	200 mA 5 VDC max.
Fuse Rating	3 A 250 V (5.2-dia.x20)
Power for External Supply	N/A
Weight	400 g max.
Dimensions	B-shape

Circuit Configuration



Fuse: 3 A 250 V (5.2-dia.x20) MQ4 (SOC)

- Note**
1. No blown fuse detector circuit is provided.
 2. Check the fuse when there is no output.

Terminal Connections

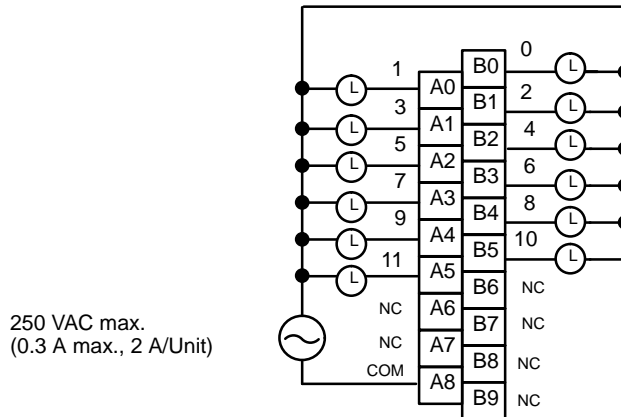

Triac Output Unit C200H-OA223

Max. Switching Capacity	1.2 A 250 VAC, 50/60 Hz (4 A/Unit)
Max. Inrush Current	15 A (pulse width: 100 ms) 30 A (pulse width: 10 ms)
Min. Switching Capacity	100 mA 10 VAC/50 mA 24 VAC/10 mA 100 VAC min.
Leakage Current	1.5 mA (120 VAC) max./3 mA (240 VAC) max.
Residual Voltage	1.5 VAC max. (50 to 1,200 mA)/ 5 VAC max. (10 to 50 mA)
ON Response Time	1 ms max.
OFF Response Time	1/2 of load frequency+1 ms or less.
No. of Circuits	1 (8 points/common)
Internal Current Consumption	180 mA 5 VDC max.
Fuse Rating	5 A 250 V (5.2-dia.x20)
Power for External Supply	N/A
Weight	300 g max.
Dimensions	E-shape

Circuit Configuration

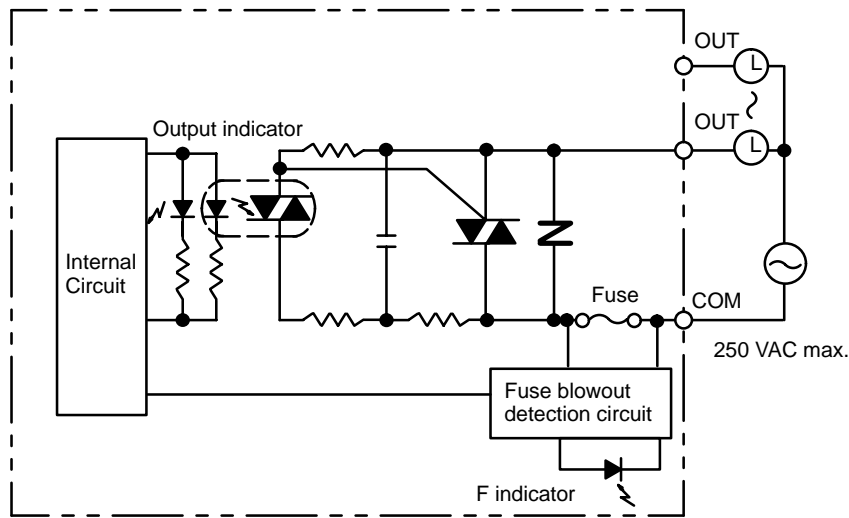

Fuse: 5 A 250 V (5.2-dia.x20) HT (SOC)

Note When the fuse blows, the F indicator lights and bit 08 turns ON. Bits 08 through 15 cannot be used as IR bits.

Terminal Connections

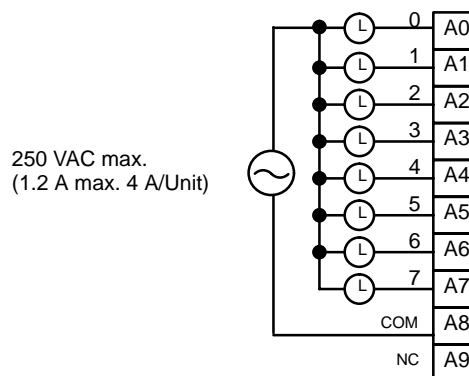

Triac Output Unit C200H-OA224

Max. Switching Capacity	0.5 A 250 VAC, 50/60 Hz (2 A/Unit)
Max. Inrush current	10 A (pulse width: 100ms) 20 A (pulse width: 10 ms)
Min. Switching Capacity	100 mA 10 VAC/50 mA 24 VAC/10 mA 100 VAC min.
Leakage Current	1.5 mA (120 VAC) max./3 mA (240 VAC) max.
Residual Voltage	1.5 VAC max. (50 to 500 mA)/5 VAC max. (10 to 50 mA)
ON Response Time	1 ms max.
OFF Response Time	1/2 of load frequency + 1 ms or less.
No. of Circuits	1 (12 points/common)
Internal Current Consumption	270 mA 5 VDC max.
Fuse Rating	3.15 A 250 V (5.2-dia.x20)
Power for External Supply	N/A
Weight	300 g max.
Dimensions	B-shape

Circuit Configuration

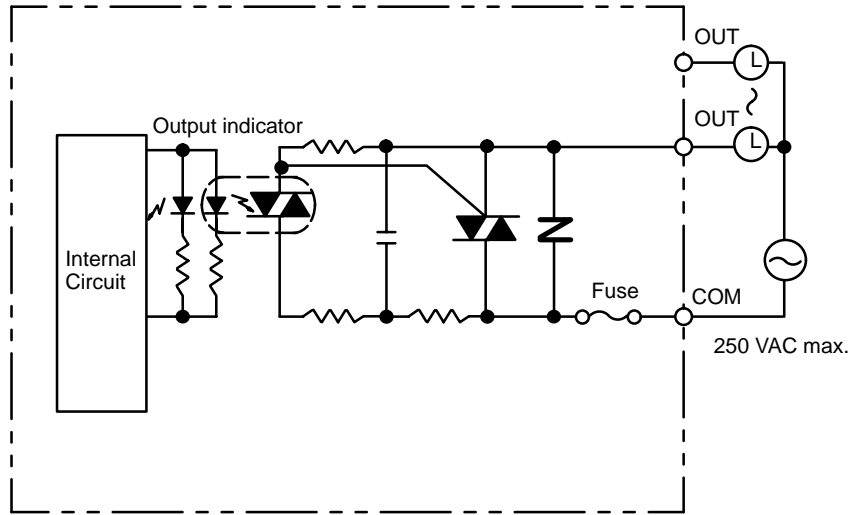

Fuse: 3.15 A 250 V (5.2-dia.x20) MT4 (SOC)

- Note**
1. No blown fuse detector circuit is provided.
 2. Check the fuse when there is no output.

Terminal Connections

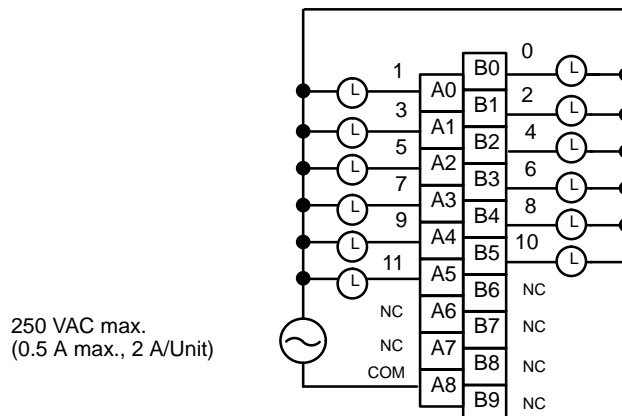

Contact Output Unit C200H-OC221

Max. Switching Capacity	2 A 250 VAC ($\cos\phi = 1$), 2 A 250 VAC ($\cos\phi = 0.4$), 2 A 24 VDC (8 A/Unit)
Min. Switching Capacity	10 mA 5 VDC
Relay	G6B-1174P-FD-US (24 VDC) w/socket
Service Life of Relay	Electrical: 500,000 operations (resistive load)/ 100,000 operations (inductive load) Mechanical: 50,000,000 operations
ON Response Time	10 ms max.
OFF Response Time	10 ms max.
No. of Circuits	1 (8 points/common)
Internal Current Consumption	10 mA 5 VDC max. 75 mA 26 VDC (8 points ON simultaneously.)
Weight	250 g max.
Dimensions	A-shape

Circuit Configuration

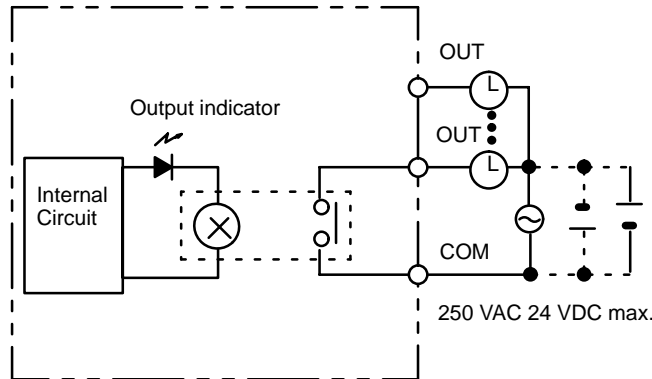

Terminal Connections

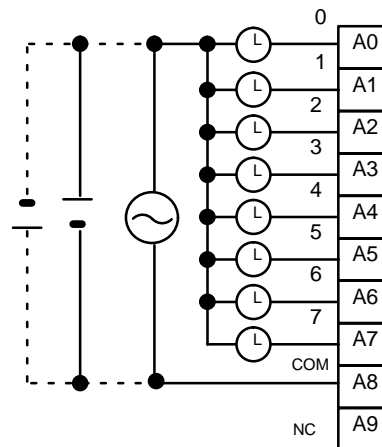

250 VAC 24 VDC max.
(inductive load: 2 A resistive load: 2 A) (8 A/Unit)

Contact Output Unit C200H-OC222

Max. Switching Capacity	2 A 250 VAC ($\cos\phi = 1$), 2 A 250 VAC ($\cos\phi = 0.4$), 2 A 24 VDC (8 A/Unit)
Min. Switching Capacity	10 mA 5 VDC
Relay	G6B-1174P-FD-US (24 VDC) w/socket
Service Life of Relay	Electrical: 500,000 operations (resistive load)/ 100,000 operations (inductive load) Mechanical: 50,000,000 operations
ON Response Time	10 ms max.
OFF Response Time	10 ms max.
No. of Circuits	1 (12 points/common) 8 points max. can be ON simultaneously.
Internal Current Consumption	10 mA 5 VDC max. 75 mA 26 VDC (8 points ON simultaneously.)
Weight	300 g max.
Dimensions	B-shape

Circuit Configuration

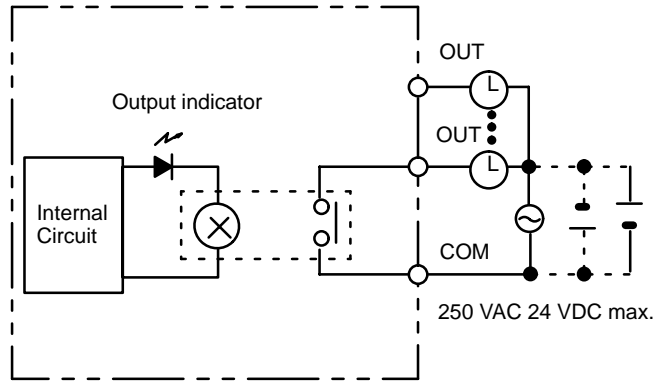

Terminal Connections

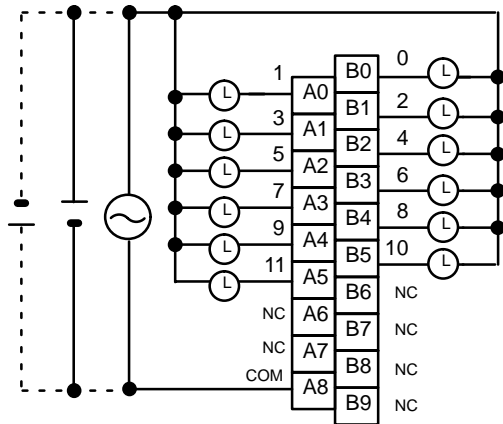

250 VAC 24 VDC max.
(inductive load: 2 A resistive load: 2 A) (8 A/Unit)

Contact Output Unit C200H-OC223

Max. Switching Capacity	2 A 250 VAC ($\cos\phi = 1$), 2 A 250 VAC ($\cos\phi = 0.4$), 2 A 24 VDC (10 A/Unit)
Min. Switching Capacity	10 mA 5 VDC
Relay	G6B-1174-P-FD-US (24 VDC) w/socket
Service Life of Relay	Electrical: 500,000 operations (resistive load)/ 100,000 operations (inductive load) Mechanical: 50,000,000 operations
ON Response Time	10 ms max.
OFF Response Time	10 ms max.
No. of Circuits	5 independent contacts
Internal Current Consumption	10 mA 5 VDC max. 75 mA 26 VDC (8 points ON simultaneously.)
Weight	250 g max.
Dimensions	A-shape

Circuit Configuration

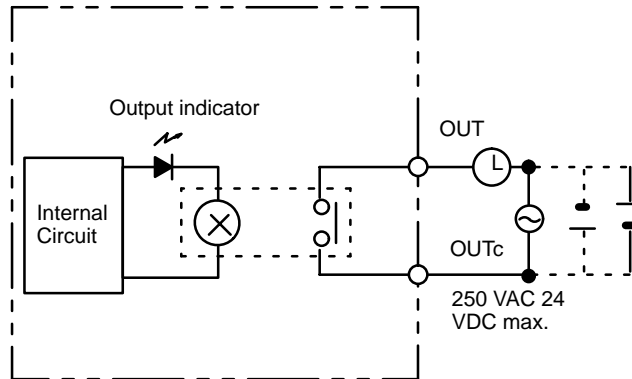

Terminal Connections

250VAC 24 VDC max.
(inductive load: 2 A
resistive load: 2 A)
(10 A/Unit)

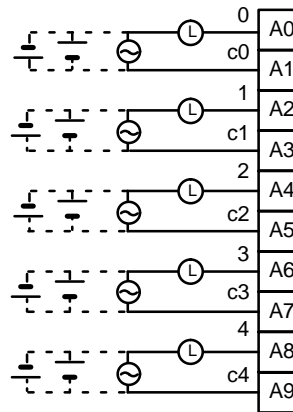

Contact Output Unit C200H-OC224

Max. Switching Capacity	2 A 250 VAC ($\cos\phi = 1$), 2 A 250 VAC ($\cos\phi = 0.4$), 2 A 24 VDC (16 A/Unit)
Min. Switching Capacity	10 mA 5 VDC
Relay	G6B-1174-P-FD-US (24 VDC) w/socket
Service Life of Relay	Electrical: 500,000 operations (resistive load)/ 100,000 operations (inductive load) Mechanical: 50,000,000 operations
ON Response Time	10 ms max.
OFF Response Time	10 ms max.
No. of Circuits	8 independent contacts
Internal Current Consumption	10 mA 5 VDC max. 75 mA 26 VDC (8 points ON simultaneously.)
Weight	300 g max.
Dimensions	B-shape

Circuit Configuration

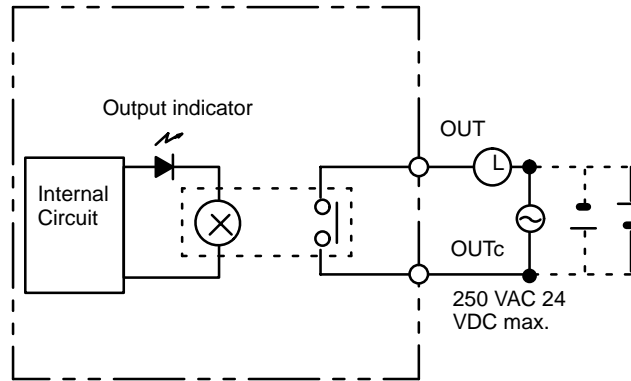

Terminal Connections

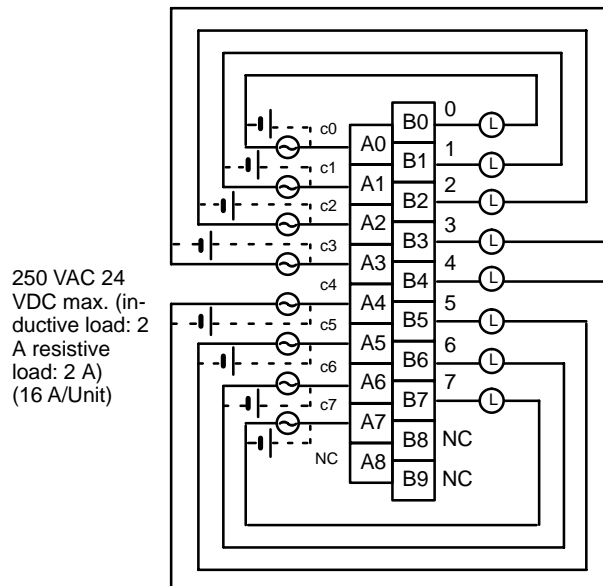

Contact Output Unit C200H-OC225

Max. Switching Capacity	2 A 250 VAC ($\cos\phi = 1$), 2 A 250 VAC ($\cos\phi = 0.4$), 2 A 24 VDC (8 A/Unit)
Min. Switching Capacity	10 mA 5 VDC
Relay	G6B-1174P-FD-US (24 VDC) w/socket
Service Life of Relay	Electrical: 500,000 operations (resistive load)/ 100,000 operations (inductive load) Mechanical: 50,000,000 operations
ON Response Time	10 ms max.
OFF Response Time	10 ms max.
No. of Circuits	1 (16 points/common) 8 points max. can be ON simultaneously.
Internal Current Consumption	50 mA 5 VDC max. 75 mA 26 VDC (8 points ON simultaneously.)
Weight	400 g max.
Dimensions	B-shape

Circuit Configuration

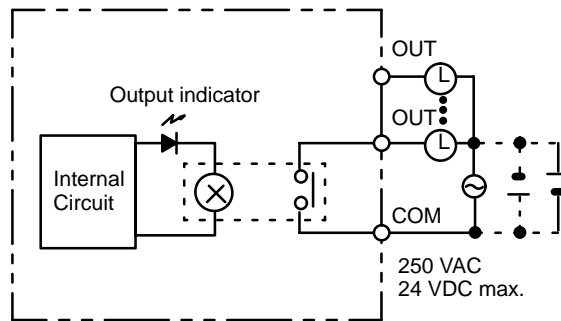

Terminal Connections

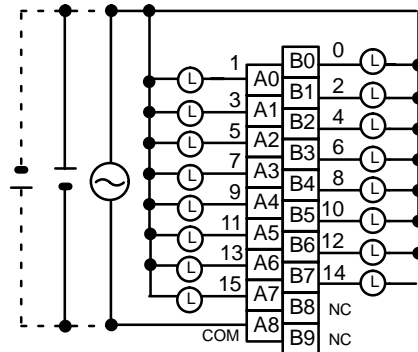

250 VAC 24 VDC max.
(inductive load: 2 A resistive load: 2 A) (8 A/Unit)

- Note**
1. This Unit must be mounted to a C200H-BC□□1-V1/V2 Backplane.
 2. This Unit might overheat if more than 8 output points are turned ON simultaneously.

Contact Output Unit C200H-OC222V

Max. Switching Capacity	2 A 250 VAC ($\cos\phi = 1$), 2 A 250 VAC ($\cos\phi = 0.4$), 2 A 24 VDC (8 A/Unit)
Min. Switching Capacity	10 mA 5 VDC
Relay	G6R-1 (24 VDC) w/socket
Service Life of Relay	Electrical: 300,000 operations Mechanical: 10,000,000 operations
ON Response Time	15 ms max.
OFF Response Time	15 ms max.
No. of Circuits	1 (12 points/common) 8 points max. can be ON simultaneously.
Internal Current Consumption	8 mA 5 VDC max. 90 mA 26 VDC (8 points ON simultaneously.)
Weight	400 g max.
Dimensions	B-shape

Circuit Configuration

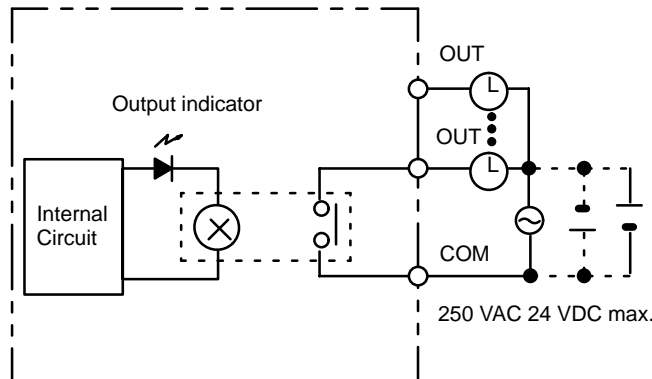

Terminal Connections

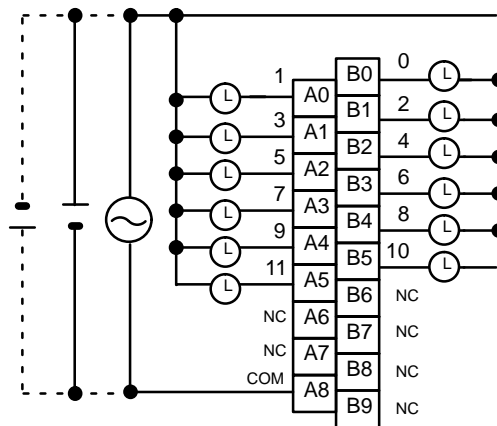

250 VAC 24 VDC max.
(inductive load: 2 A resistive load: 2 A) (8 A/Unit)

Contact Output Unit C200H-OC226

Max. Switching Capacity	2 A 250 VAC ($\cos\phi = 1$), 2 A 250 VAC ($\cos\phi = 0.4$), 2 A 24 VDC (8 A/Unit)
Min. Switching Capacity	10 mA 5 VDC
Relay	G6R-1 (24 VDC) w/socket
Service Life of Relay	Electrical: 300,000 operations Mechanical: 10,000,000 operations
ON Response Time	15 ms max.
OFF Response Time	15 ms max.
No. of Circuits	1 (16 points/common) 8 points max. can be ON simultaneously.
Internal Current Consumption	30 mA 5 VDC max. 90 mA 26 VDC (8 points ON simultaneously.)
Weight	500 g max.
Dimensions	Extended B-shape

Circuit Configuration

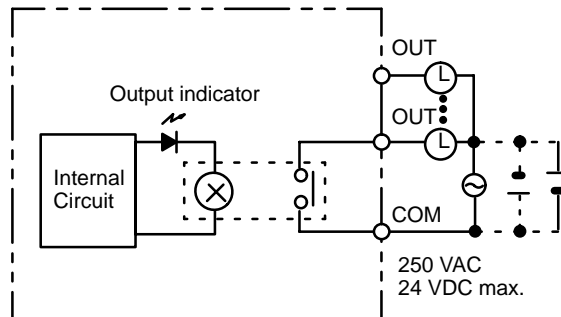

Terminal Connections

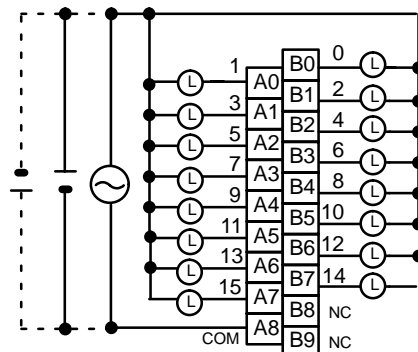

250 VAC 24 VDC max.
(inductive load: 2 A resistive load: 2 A) (8 A/Unit)

Contact Output Unit C200H-OC224V

Max. Switching Capacity	2 A 250 VAC ($\cos\phi = 1$), 2 A 250 VAC ($\cos\phi = 0.4$), 2 A 24 VDC (16 A/Unit)
Min. Switching Capacity	10 mA 5 VDC
Relay	G6R-1 (24 VDC) w/socket
Service Life of Relay	Electrical: 300,000 operations Mechanical: 10,000,000 operations
ON Response Time	15 ms max.
OFF Response Time	15 ms max.
No. of Circuits	8 independent contacts
Internal Current Consumption	10 mA 5 VDC max. 90 mA 26 VDC (8 points ON simultaneously.)
Weight	350 g max.
Dimensions	B-shape

Circuit Configuration

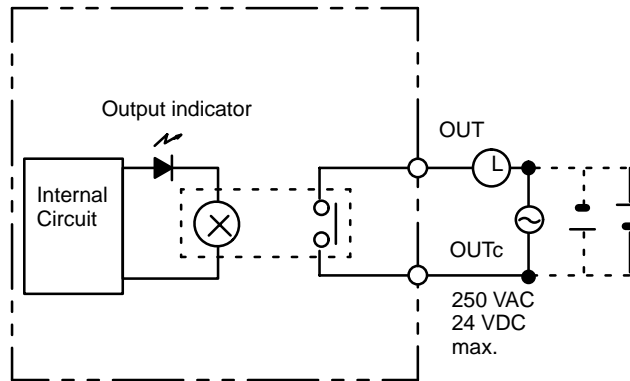

Terminal Connections

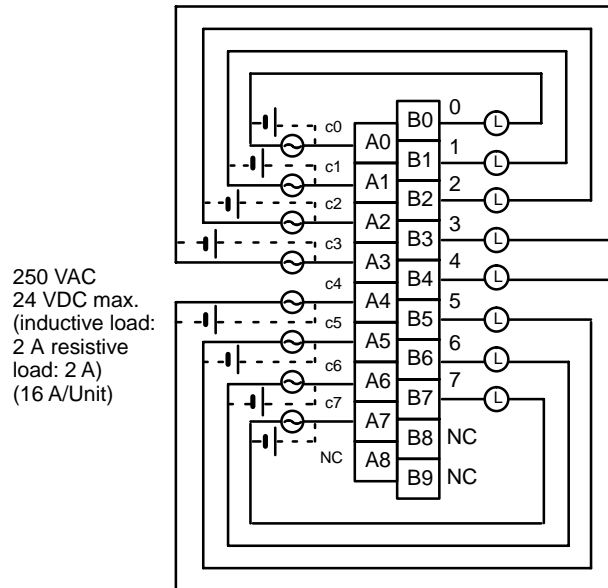

Life Expectancy of Contact Output Unit

The C200H-OC221/222/223/224/225 Contact Output Unit uses OMRON's G6B-1174P-FD-US Relay. The life of the G6B-1174P-FD-US Relay varies with the contact current and ambient temperature. Refer to the following graphs to calculate this value.

Contact Current vs. Life Expectancy

Conditions

Switching frequency: 1,800 times/hour max.

Ambient temperature: 23°C

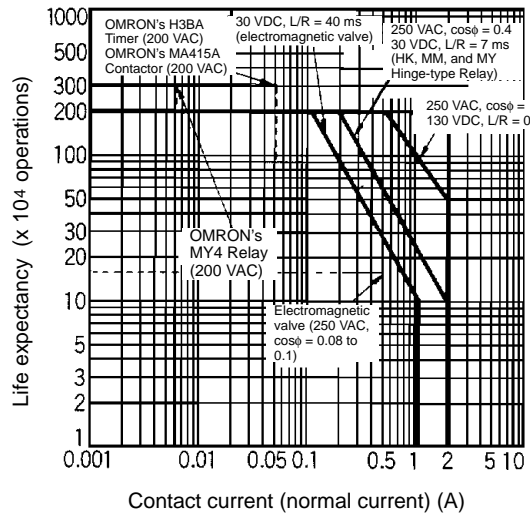

Ambient Temperature vs. Life Expectancy

Conditions

Switching frequency: 1,800 times/hour max.

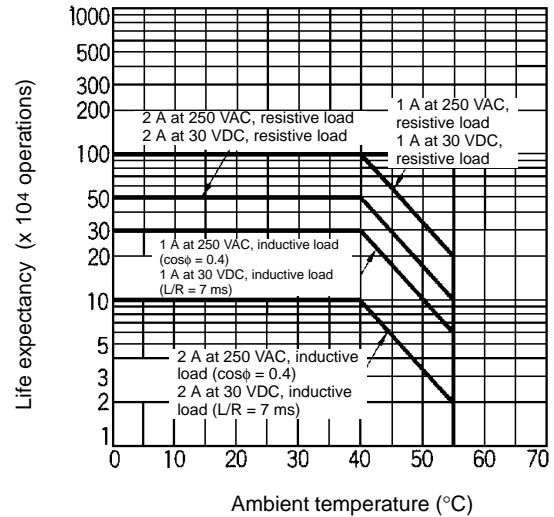

- Note**
1. If the Contact Output Unit is panel-mounted, the temperature inside the panel represents the ambient temperature.
 2. The life of the Relay at an ambient temperature of 55°C is one-fifth the life of the Relay at room temperature (0° to 40°C).

Inductive Load

The life of the Relay varies with the load inductance. If any inductive load is connected to the Contact Output Unit, use an arc killer with the Contact Output Unit using an inductive load.

Be sure to connect a diode in parallel with every DC inductive load that is connected to the Contact Output Unit.

Contact Protection Circuit

Arc killers are used with the Contact Output Unit in order to prolong the life of each Relay mounted to the Contact Output Unit, prevent noise, and reduce the generation of carbide and nitrate deposits.

Note Arc killers used with the Contact Output Unit can delay the resetting time required by each Relay mounted to the Contact Output Unit.

Arc killer circuit examples are listed in the following table.

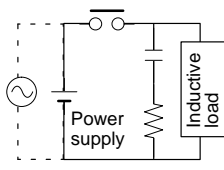
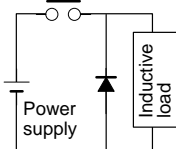
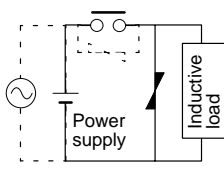
Circuit	Current		Characteristic	Required element
	AC	DC		
<p>CR method</p> 	Yes	Yes	<p>If the load is a relay or solenoid, there is a time lag between the moment the circuit is opened and the moment the load is reset.</p> <p>If the supply voltage is 24 or 48 V, insert the arc killer in parallel with the load. If the supply voltage is 100 to 200 V, insert the arc killer between the contacts.</p>	<p>The capacitance of the capacitor must be 1 to 0.5 μF per contact current of 1 A and resistance of the resistor must be 0.5 to 1 Ω per contact voltage of 1 V. These values, however, vary with the load and the characteristics of the relay. Decide these values from experiments, and take into consideration that the capacitance suppresses spark discharge when the contacts are separated and the resistance limits the current that flows into the load when the circuit is closed again.</p> <p>The dielectric strength of the capacitor must be 200 to 300 V. If the circuit is an AC circuit, use a capacitor with no polarity.</p>
<p>Diode method</p> 	No	Yes	<p>The diode connected in parallel with the load changes energy accumulated by the coil into a current, which then flows into the coil so that the current will be converted into Joule heat by the resistance of the inductive load.</p> <p>This time lag, between the moment the circuit is opened and the moment the load is reset, caused by this method is longer than that caused by the CR method.</p>	<p>The reversed dielectric strength value of the diode must be at least 10 times as large as the circuit voltage value. The forward current of the diode must be the same as or larger than the load current.</p> <p>The reversed dielectric strength value of the diode may be two to three times larger than the supply voltage if the arc killer is applied to electronic circuits with low circuit voltages.</p>
<p>Varistor method</p> 	Yes	Yes	<p>The varistor method prevents the imposition of high voltage between the contacts by using the constant voltage characteristic of the varistor. There is time lag between the moment the circuit is opened and the moment the load is reset.</p> <p>If the supply voltage is 24 or 48 V, insert the varistor in parallel with the load. If the supply voltage is 100 to 200 V, insert the varistor between the contacts.</p>	---

Note Do not connect a capacitor as an arc killer in parallel with an inductive load as shown in the following diagram. This arc killer is very effective for preventing spark discharge at the moment when the circuit is opened. However when the contacts are closed, the contacts may be welded due to the current charged in the capacitor.

DC inductive loads can be more difficult to switch than resistive loads. If appropriate arc killers are used, however, DC inductive loads will be as easy to switch as resistive loads.

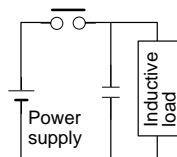

Transistor Output Unit C200H-OD211

Max. Switching Capacity	0.3 A 24 VDC $+10\%/_{-15\%}$ (2 A/Unit)
Min. Switching Capacity	None
Leakage Current	0.1 mA max.
Residual Voltage	1.4 V max.
ON Response Time	0.2 ms max.
OFF Response Time	0.3 ms max.
No. of Circuits	1 (12 points/common)
Internal Current Consumption	160 mA 5 VDC max.
Fuse Rating	5 A 125 V (5.2-dia.x20)
Power for External Supply	25 mA 24 VDC $+10\%/_{-15\%}$ min.
Weight	300 g max.
Dimensions	B-shape

Circuit Configuration

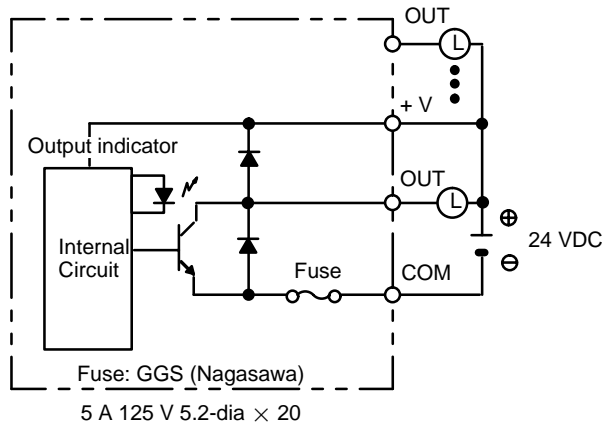

- Note**
1. No blown fuse detector circuit is provided.
 2. Check the fuse when there is no output.

Terminal Connections

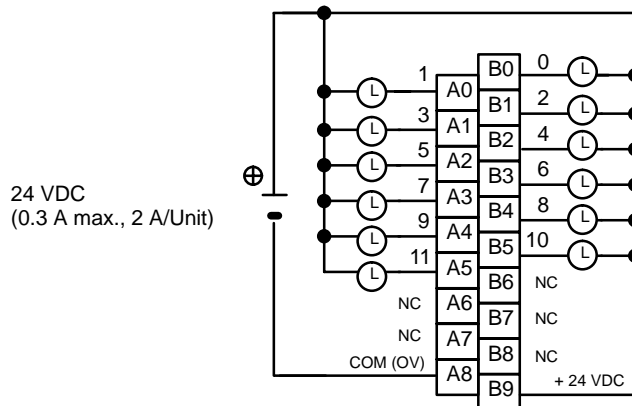

Note Be sure to supply power to B9; otherwise current will leak through the load while the output is OFF.

Transistor Output Unit C200H-OD212

Max. Switching Capacity	0.3 A 24 VDC $+10\%/-15\%$ (4.8 A/Unit)
Min. Switching Capacity	None
Leakage Current	0.1 mA max.
Residual Voltage	1.4 V max.
ON Response Time	0.2 ms max.
OFF Response Time	0.3 ms max.
No. of Circuits	1 (16 points/common)
Internal Current Consumption	180 mA 5 VDC max.
Fuse Rating	8 A 125 V (5.2-dia.x20)
Power for External Supply	35 mA 24 VDC $+10\%/-15\%$ min.
Weight	350 g max.
Dimensions	B-shape

Circuit Configuration



- Note**
1. No blown fuse detector circuit is provided.
 2. Check the fuse when there is no output.

Terminal Connections

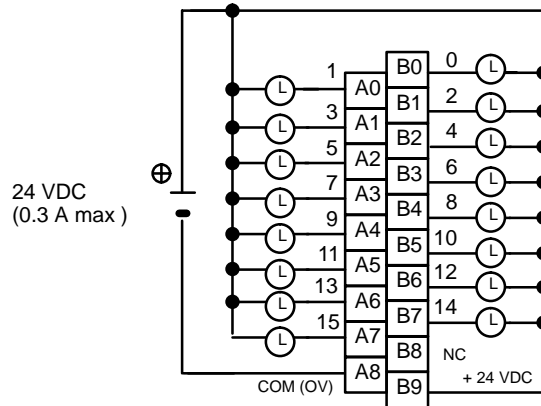

- Note**
1. Be sure to supply power to B9; otherwise current will leak through the load while the output is OFF.
 2. This Unit must be mounted to a C200H-BC□□1-V1/V2 Backplane.

Transistor Output Unit C200H-OD213

Max. Switching Capacity	2.1 A 24 VDC $+10\%/_{-15\%}$ (5.2 A/Unit) NPN output
Min. Switching Capacity	None
Leakage Current	0.1 mA max.
Residual Voltage	1.4 V max.
ON Response Time	0.2 ms max.
OFF Response Time	0.3 ms max.
No. of Circuits	1 (8 points/common)
Internal Current Consumption	140 mA 5 VDC max.
Fuse Rating	8 A 125 V (5.2-dia.x20)
Power for External Supply	30 mA 24 VDC $+10\%/_{-15\%}$ min.
Weight	250 g max.
Dimensions	A-shape

Circuit Configuration

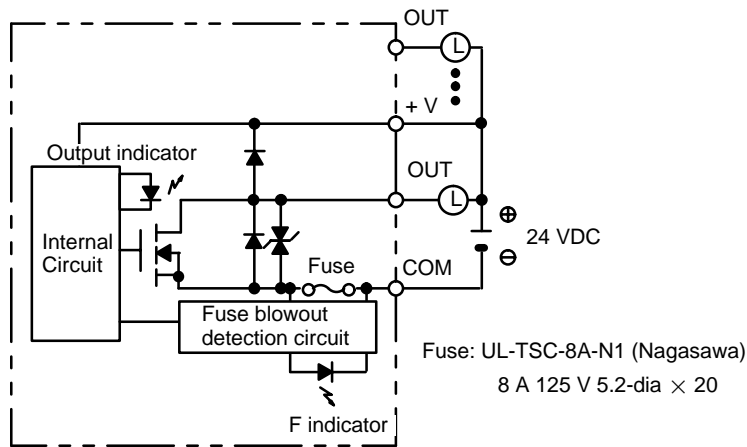

Note When the fuse blows, the F indicator lights and bit 08 turns ON. Bits 08 through 15 cannot be used as IR bits.

Terminal Connections

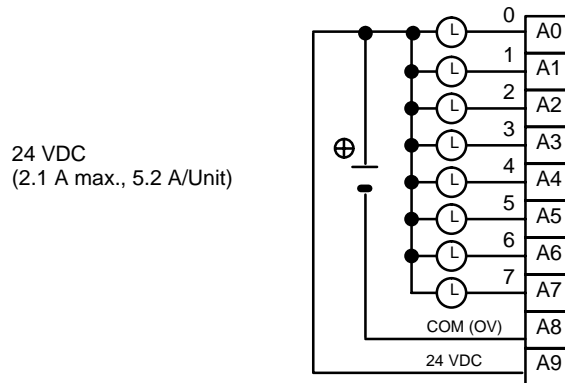

Note Be sure to supply power to A9; otherwise current will leak through the load while the output is OFF.

Transistor Output Unit C200H-OD214 (Load Short-circuit Protection Provided)

Max. Switching Capacity	24 VDC +10%/-15% 0.8 A (2.4 A/Unit) surge current 2 A (source type) PNP output	
Min. Switching Capacity	None	
Leakage Current	1 mA max.	
Residual Voltage	1.5 V max.	
ON Response Time	1 ms max.	
OFF Response Time	1 ms max.	
No. of Circuits	1 (8 points/common)	
Internal Current Consumption	140 mA 5 VDC max.	
Fuse Rating	Short-circuit protection	Overcurrent protection
		Thermal protection
Power for External Supply	150 mA 24 VDC +10%/-15% min.	
Weight	250 g max.	
Dimensions	A-shape	

Circuit Configuration

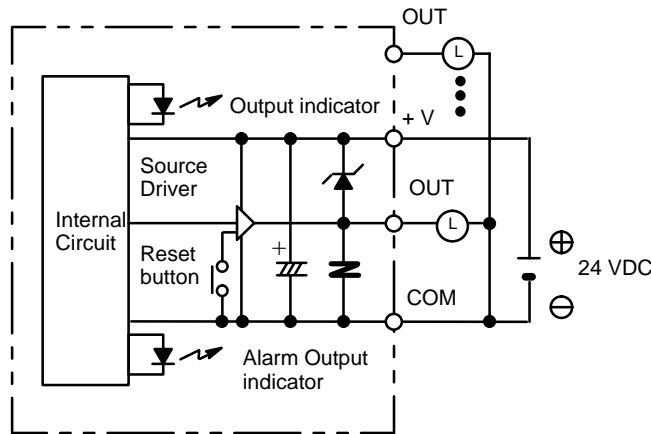

Terminal Connections

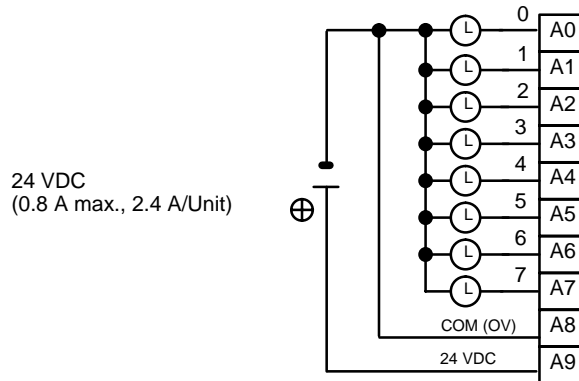

Note Be sure to supply power to A9; otherwise current will leak through the load while the output is OFF.

C200H-OD214 Short-Circuit Protection

The C200H-OD214 Output Unit is equipped with two types of short-circuit protection: overcurrent protection and thermal protection. Any short-circuit must be eliminated immediately in order to avoid damage to the Unit.

Overcurrent Protection

When the output current reaches 2 A, the alarm output turns ON, and the alarm indicator lights. Make sure the surge current of the load does not exceed 2 A, or the alarm may be activated.

Thermal Protection

When the junction temperature of the output transistor reaches its upper limit, the output turns OFF, the alarm output turns ON, and the alarm indicator blinks. But the output transistor is provided with a heat sink. So in some cases, when the output is short-circuited the thermal protection may not activate because the extra heat is dissipated by the heat sink. However, the alarm indicator will still light and the alarm output will still turn ON.

How It Works

When the short-circuit protection activates, the output displays the characteristic shown below.



Each pair of outputs share one alarm indicator and one alarm output bit as shown below (bits 12 through 15 cannot be used as IR bits)

Output No.	0	1	2	3	4	5	6	7
Alarm indicator No.	0		2		4		6	
Alarm Output Point No.			08		09		10	

Both the alarm indicator and alarm output bit for the short-circuited output turn ON even if only one of the outputs is short-circuited. Both outputs should be disconnected until the short-circuit can be traced.

Clearing the Alarm

When the short-circuit has been eliminated, reset the Unit by pressing the reset button. The alarm indicator will go out, the alarm output will turn OFF, and the output will be reset.

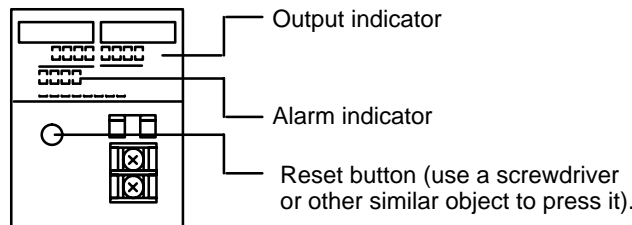

Programming Example

If there is a short-circuit in an output, we want the program to turn that output OFF. Assume that the Unit is mounted at word 000. A program to turn OFF output bits 00 and 01 is shown below.

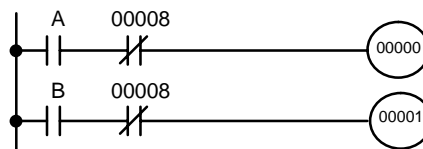

Since alarm output bit 08 covers both output bits 00 and 01, both these outputs are forced OFF as soon as output bit 08 turns ON (bits A and B can be any other bits required in the program).

Transistor Output Unit C200H-OD216

Max. Switching Capacity	0.3 A 5 to 24 VDC
Min. Switching Capacity	10 mA 5 VDC
Leakage Current	0.1 mA max.
Residual Voltage	1.5 V max.
ON Response Time	1.5 ms max.
OFF Response Time	2 ms max.
No. of Circuits	1 (8 points/common) positive common (source type)
Internal Current Consumption	10 mA 5 VDC max. 75 mA 26 VDC (8 points ON simultaneously.)
Fuse Rating	None
Power for External Supply	N/A
Weight	250 g max.
Dimensions	A-shape

Circuit Configuration

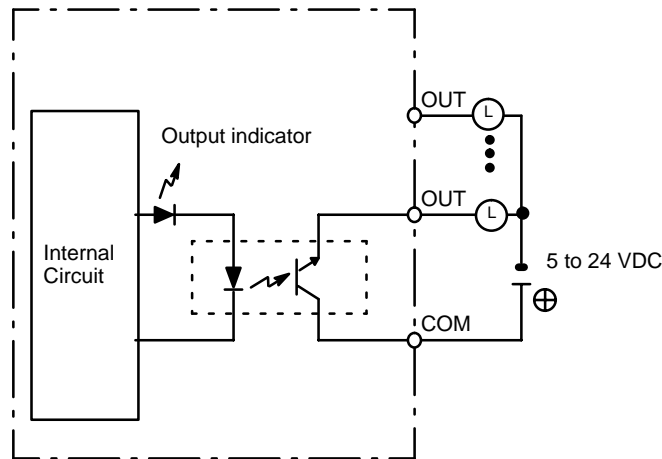

Terminal Connections



Transistor Output Unit C200H-OD217

Max. Switching Capacity	0.3 A 5 to 24 VDC
Min. Switching Capacity	10 mA 5 VDC
Leakage Current	0.1 mA max.
Residual Voltage	1.5 V max.
ON Response Time	1.5 ms max.
OFF Response Time	2 ms max.
No. of Circuits	1 (12 points/common) positive common (source type)
Internal Current Consumption	10 mA 5 VDC max. 75 mA 26 VDC (8 points ON simultaneously.)
Fuse Rating	None
Power for External Supply	N/A
Weight	300 g max.
Dimensions	B-shape

Circuit Configuration

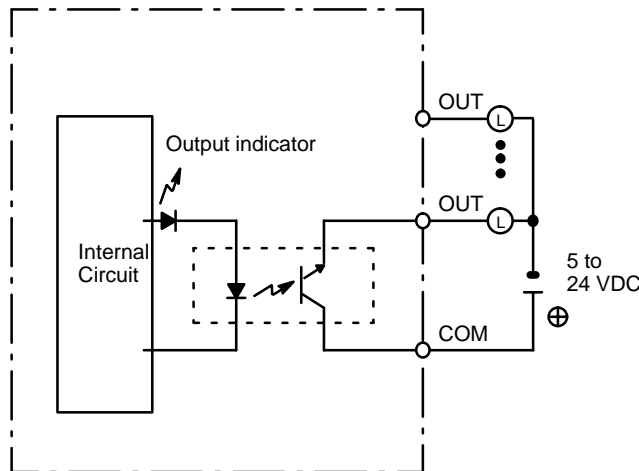

Terminal Connections

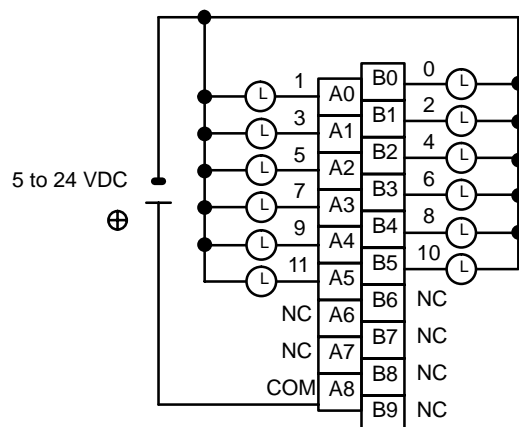

Transistor Output Unit C200H-OD411

Max. Switching Capacity	12 to 48 VDC 1 A (3 A/Unit)
Min. Switching Capacity	None
Leakage Current	0.1 mA max.
Residual Voltage	1.4 V max.
ON Response Time	0.2 ms max.
OFF Response Time	0.3 ms max.
No. of Circuits	1 (8 points/common)
Internal Current Consumption	140 mA 5 VDC max.
Fuse Rating	5 A 125 V (5.2-dia.x20)
Power for External Supply	30 mA 12 to 48 VDC min.
Weight	250 g max.
Dimensions	A-shape

Circuit Configuration

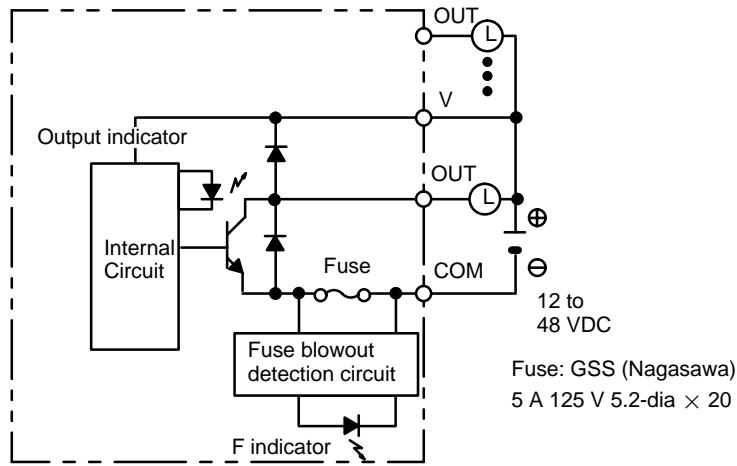

Note When the fuse blows, the F indicator lights and bit 08 turns ON. Bits 08 through 15 cannot be used as IR bits.

Terminal Connections

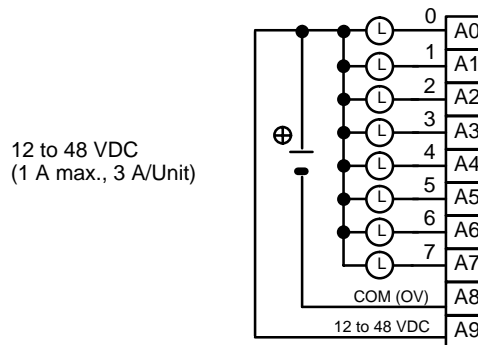

Note Be sure to supply power to A9; otherwise current will leak through the load while the output is OFF.

Transistor Output Unit C200H-OD21A (Load Circuit Protection Provided)

Max. Switching Capacity	24 VDC +10%/−15%, 1.0 A (4 A/Unit) surge current 1.6 A (sourcing type) PNP output
Min. Switching Capacity	None
Leakage Current	0.1 mA max.
Residual Voltage	0.8 V max.
ON Response Time	0.1 ms max.
OFF Response Time	0.3 ms max.
No. of Circuits	1 (16 points/common)
Internal Current Consumption	160 mA 5 VDC max.
Power for External Supply	35 mA 24 VDC +10%/−15% min.
Weight	400 g max.
Alarm Output (see note 1)	No. of outputs: 1 (2 kΩ internal resistor) Connectable Units: Only the following DC Input Units and alarm output LED indicators can be connected: C200H-ID001, ID211, ID212, IM211 (DC), IM212 (DC), ID215, ID501, MD115, MD215, MD501
Reset Input	Used when alarm output turns ON. Value will depend on the external power supply. (See note 2.)
Load Short-circuit Protection	Detection current: 1.2 A min. (1.6 A typical)
Dimensions	B-shape

Circuit Configuration

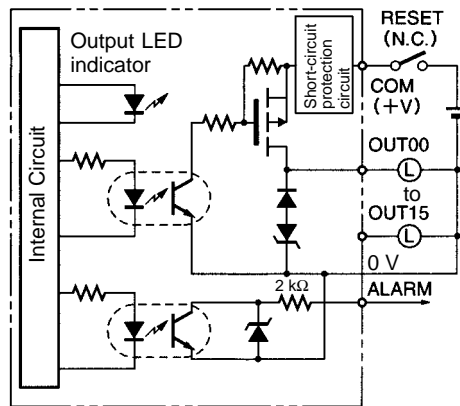

Note 1. When the short-circuit/overload protection is activated, all 16 outputs are switched OFF and the ALARM output becomes active (low level). It is possible to determine the cause of the alarm by connecting either a DC Input Unit to the alarm output or an alarm output LED indicator.

2. When alarm output turns ON, remove the cause of the overload, turn OFF the external power supply (for about 1 s), and confirm that the error has been cleared before turning ON power again and restoring output.

As indicated in the following terminal connections diagram, it is recommended that a relay or switch used solely to turn ON and OFF the Unit's external power supply be connected immediately in front of B9 (+V). In this case, use a relay or switch with a contact capacity that is greater than the current consumption of the external power supply for the Unit (35mA) + the load current.

Terminal Connections

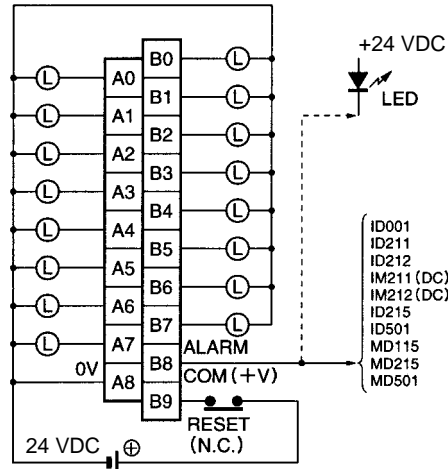

C200HS-INT01 Interrupt Input Unit

The Interrupt Input Unit temporarily interrupts the main program by means of inputs, and executes interrupt subroutines. It must be mounted to a C200HS CPU Rack, and there can be only one Interrupt Input Unit on the Rack. (It is possible to mount it to an Expansion I/O Rack, but in that case it will be treated as a Standard Input Unit and will have no interrupt functions.) Use a C200H-BC□□1-V2 Backplane. The word number of the slot position to which the Unit is mounted is allocated as eight input points.

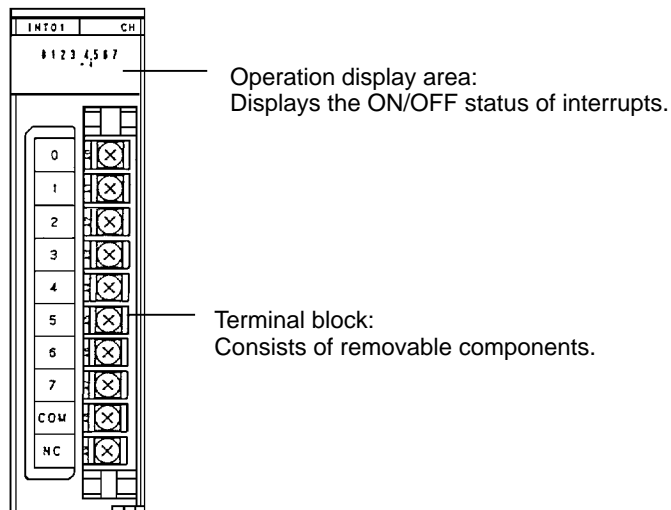

Rated Input Voltage	12 to 24 VDC +10%/−15%
Input Impedance	2 KΩ
Input Current	10 mA typical (24 VDC)
ON Voltage	10.2 VDC min.
OFF Voltage	3.0 VDC max.
ON Response Time	0.2 ms max.
OFF Response Time	0.5 ms max.
No. of Circuits	1 (8 points/common)
Internal Current Consumption	20 mA, 5 VDC max.
Weight	200 g max.

Circuit Configuration

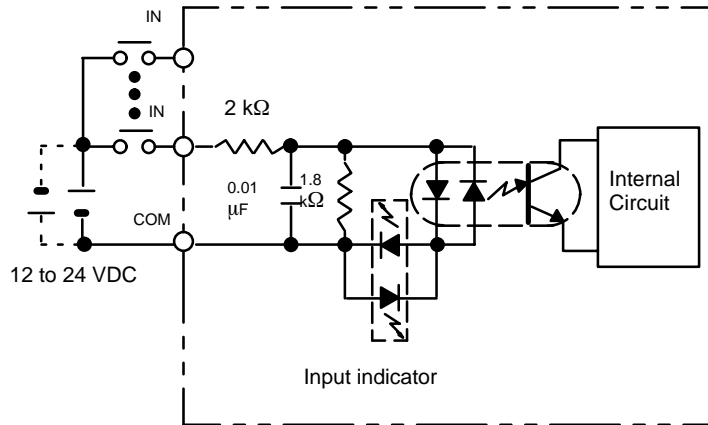

Either plus or minus can be used for the input power supply.

Terminal Connections

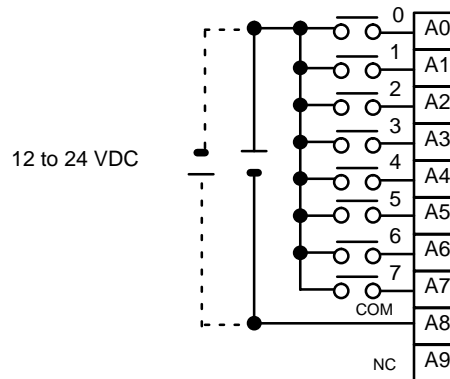

Group-2 High-density I/O Units

In the following diagrams, “m” is the first word allocated to the Unit in PC memory.

DC Input Unit C200H-ID111 (64 Points)

Rated Input Voltage	12 VDC $+10\%/-15\%$
Operating Input Voltage	10.2 to 13.2 VDC
Input Impedance	2.7 kΩ
Input Current	4.1 mA (at 12 VDC)
ON Voltage	8.0 VDC min.
OFF Voltage	3.0 VDC max.
ON Response Time	1.0 ms max.
OFF Response Time	1.0 ms max.
No. of Circuits	2 (32 points/common)
Internal Current Consumption	120 mA 5 VDC max.
Weight	250 g max.
Dimensions	D-shape

Circuit Configuration

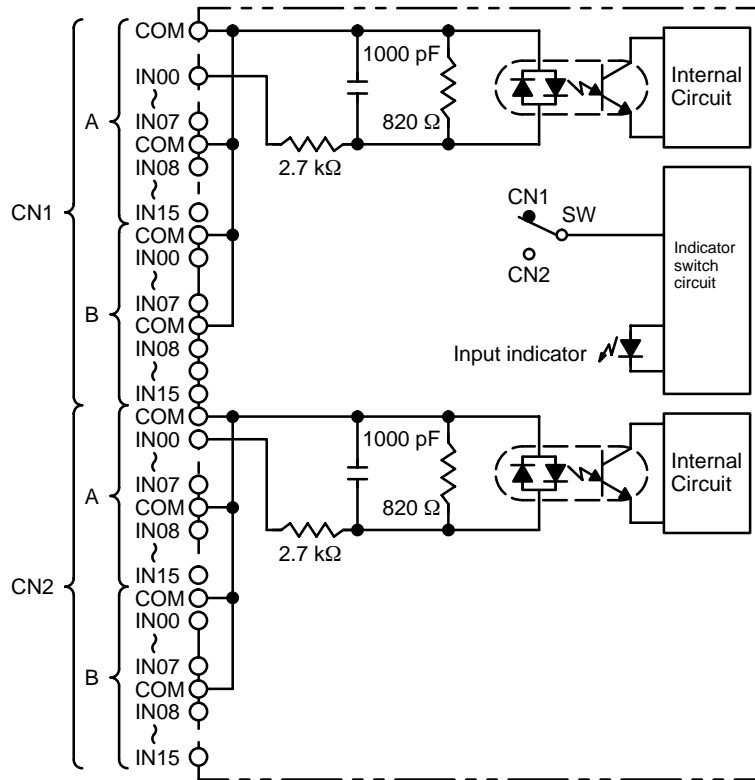

Terminal Connections

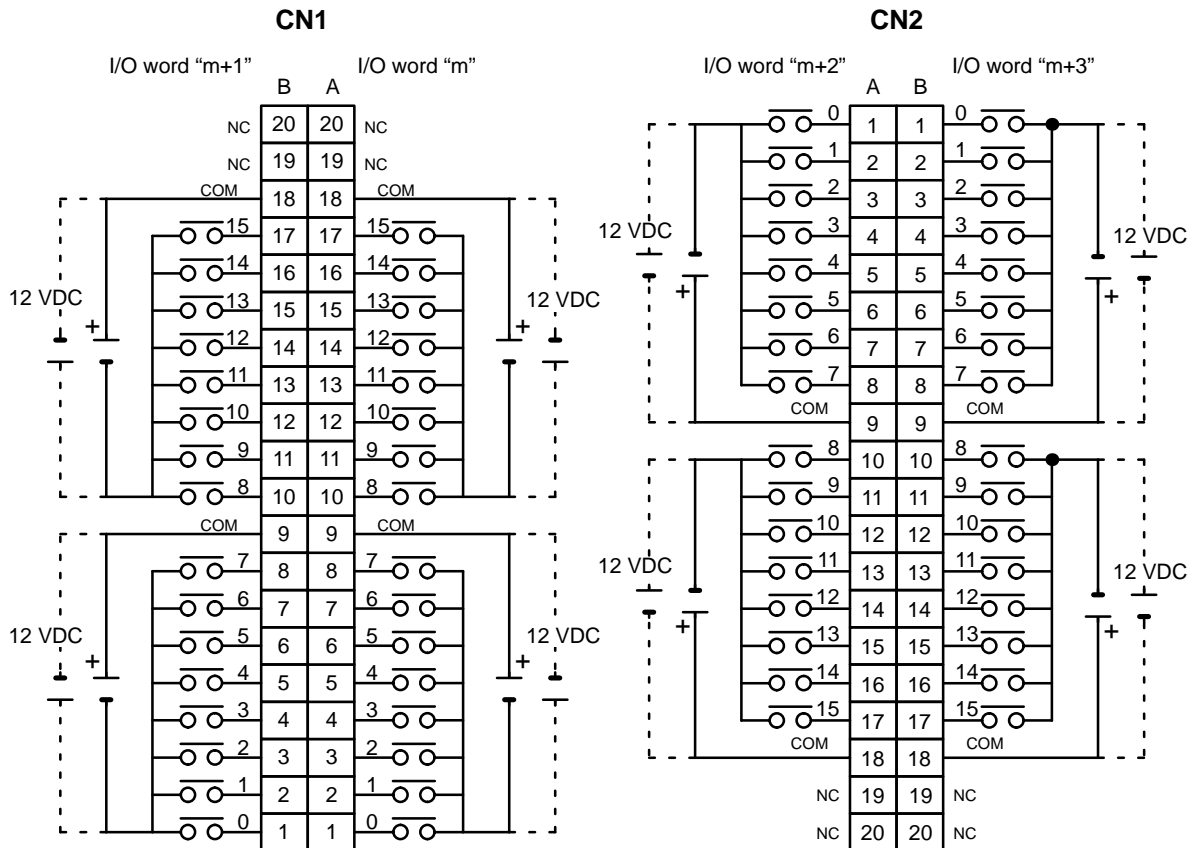

Note 1. I/O word “m” is determined by the I/O number setting ($m = IR\ 030 + 2 \times \text{I/O number}$).

- The power can be supplied in either polarity, but the same polarity must be used for all COM terminals in each connector. Connect power supply wiring to every COM terminal, even though the COM terminals in each connector are connected internally.

DC Input Unit C200H-ID216 (32 Points)

Rated Input Voltage	24 VDC
Operating Input Voltage	20.4 to 26.4 VDC
Input Impedance	5.6 kΩ
Input Current	4.1 mA (at 24 VDC)
ON Voltage	14.4 VDC min.
OFF Voltage	5.0 VDC max.
ON Response Time	1.0 ms max.
OFF Response Time	1.0 ms max.
No. of Circuits	1 (32 points/common) All 32 points cannot be turned ON simultaneously at high temperatures. Refer to the following graph.
Internal Current Consumption	100 mA 5 VDC max.
Weight	180 g max.
Dimensions	C-shape

Circuit Configuration and Simultaneously Usable Points

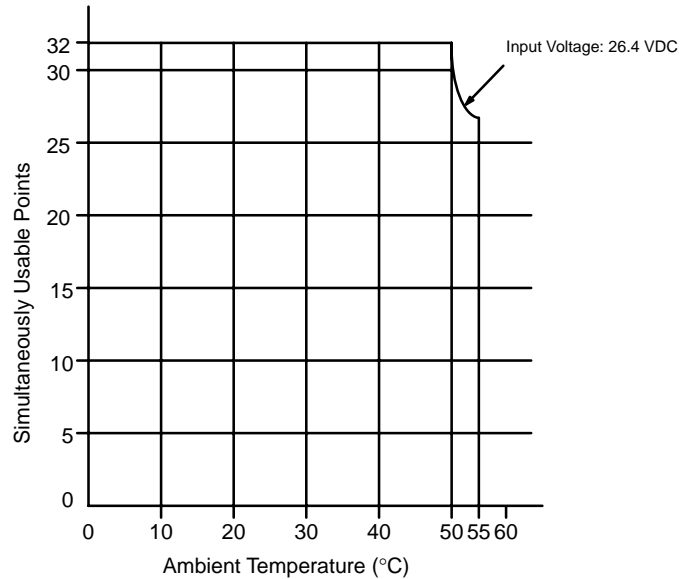
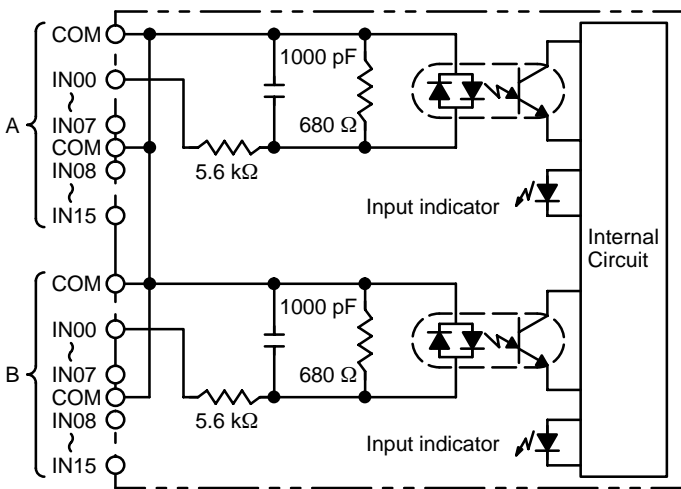

Terminal Connections

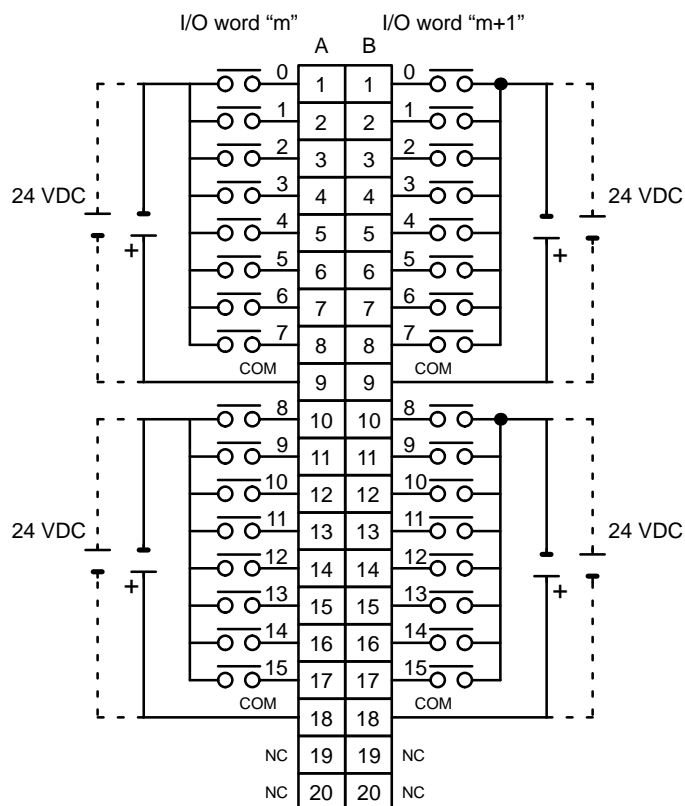

- Note**
1. I/O word “m” is determined by the I/O number setting ($m = IR\ 030 + 2 \times \text{I/O number}$).
 2. The power can be supplied in either polarity, but the same polarity must be used for all COM terminals. Connect power supply wiring to every COM terminal, even though the COM terminals are connected internally.

DC Input Unit C200H-ID217 (64 Points)

Rated Input Voltage	24 VDC
Operating Input Voltage	20.4 to 26.4 VDC
Input Impedance	5.6 kΩ
Input Current	4.1 mA (at 24 VDC)
ON Voltage	14.4 VDC min.
OFF Voltage	5.0 VDC max.
ON Response Time	1.0 ms max.
OFF Response Time	1.0 ms max.
No. of Circuits	2 (32 points/common) All 64 points cannot be turned ON simultaneously at high temperatures. Refer to the following graph.
Internal Current Consumption	120 mA 5 VDC max.
Weight	250 g max.
Dimensions	D-shape

Circuit Configuration and Simultaneously Usable Points

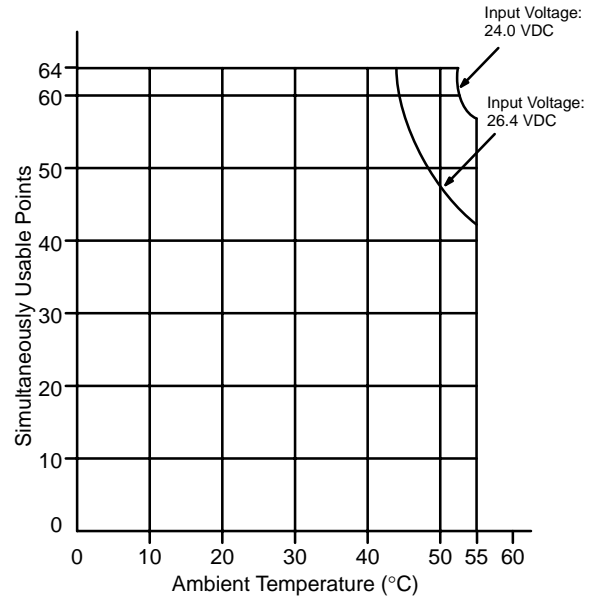

Terminal Connections



Note 1. I/O word "m" is determined by the I/O number setting ($m = IR\ 030 + 2 \times \text{I/O number}$).

- The power can be supplied in either polarity, but the same polarity must be used for all COM terminals in each connector. Connect power supply wiring to every COM terminal, even though the COM terminals in each connector are connected internally.

DC Input Unit C200H-ID218

Rated Input Voltage	24 VDC +10%/-15%
Input Impedance	3.9 kΩ
Input Current	6 mA (at 24 VDC)
ON Voltage/ON Current	15.4 VDC min./3.5 mA min.
OFF Voltage/OFF Current	5.0 VDC max./1 mA max.
ON Response Time	1.0 ms max.
OFF Response Time	1.0 ms max.
No. of Circuits	32 (32 points/common) Note The number of points that can be ON simultaneously is limited according to the ambient temperature. Refer to the following diagram for details.
Internal Current Consumption	100 mA 5 VDC max.
Weight	180 g max.

Circuit Configuration

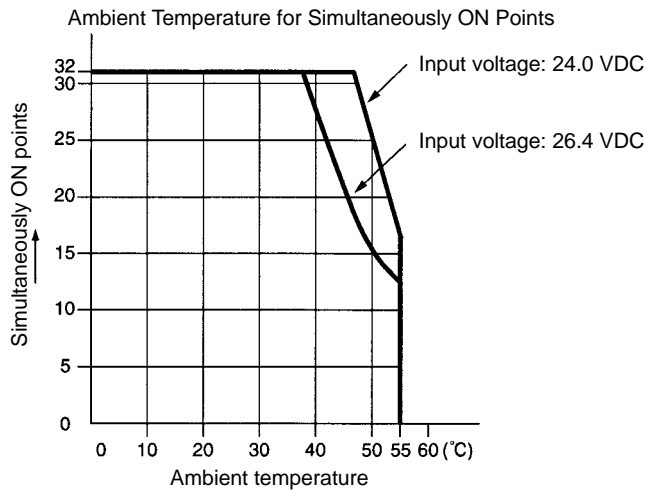

Terminal Connections

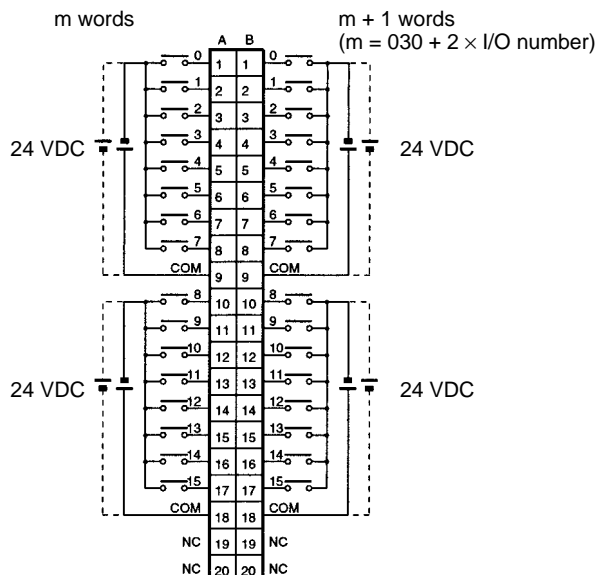

- Note**
1. The polarity of the input power supply can be either positive or negative. The polarity of all commons, however, must be the same.
 2. COM terminals must all be wired even though they are connected internally.

DC Input Unit C200H-ID219

Rated Input Voltage	24 VDC +10%/-15%
Input Impedance	3.9 kΩ
Input Current	6 mA (at 24 VDC)
ON Voltage/ON Current	15.4 VDC min./3.5 mA min.
OFF Voltage/OFF Current	5.0 VDC max./1 mA max.
ON Response Time	1.0 ms max.
OFF Response Time	1.0 ms max.
No. of Circuits	64 (32 points/common) Note The number of points that can be ON simultaneously is limited according to the ambient temperature. Refer to the following diagram for details.
Internal Current Consumption	120 mA 5 VDC max.
Weight	250 g max.

Circuit Configuration

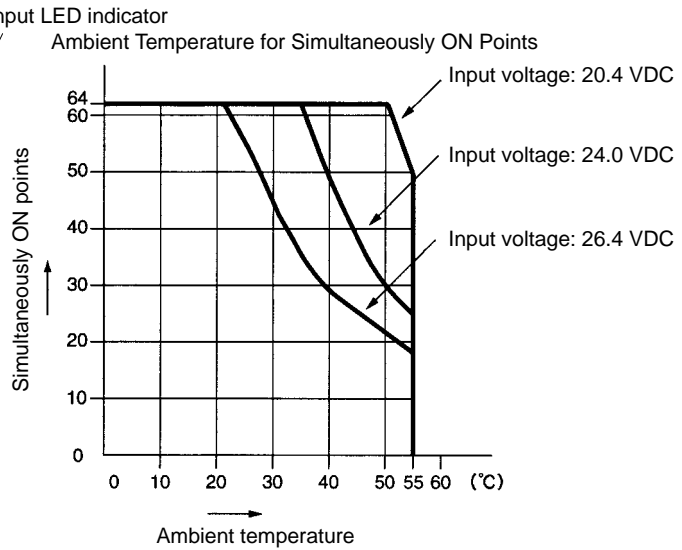
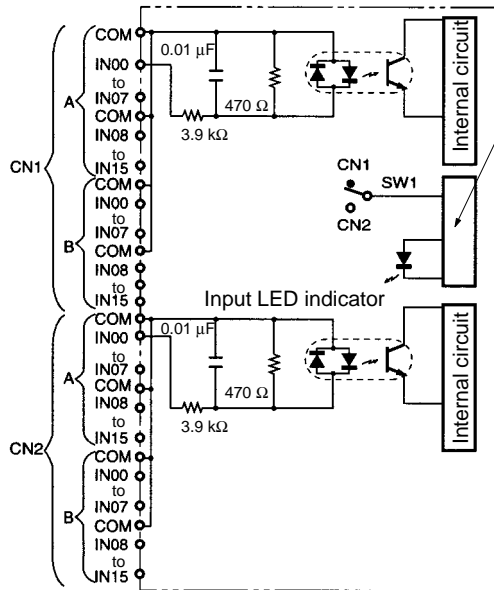

Terminal Connections

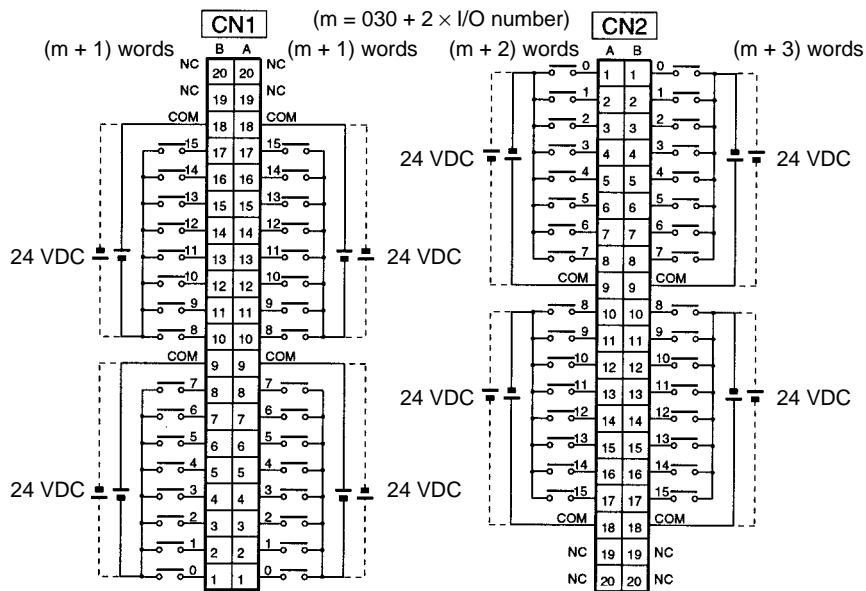

- Note**
1. The polarity of the input power supply can be either positive or negative. The polarity of all commons for CN1 and CN2, however, must be the same.
 2. COM terminals for CN1 and CN2 must all be wired even though they are connected internally.

Transistor Output Unit C200H-OD218 (32 Points)

Max. Switching Capacity	16 mA 4.5 VDC to 100 mA 26.4 VDC (see below)
Min. Switching Capacity	None
Leakage Current	0.1 mA max.
Residual Voltage	0.8 V max.
ON Response Time	0.1 ms max.
OFF Response Time	0.4 ms max.
No. of Circuits	1 (32 points/common)
Internal Current Consumption	180 mA 5 VDC max.
Fuse Rating	3.5 A (The fuse is not user-replacable.)
Power for External Supply	110 mA 5 to 24 VDC ±10% min. (3.4 mA × number of ON pts)
Weight	180 g max.
Dimensions	C-shape

Circuit Configuration and Maximum Switching Capacity

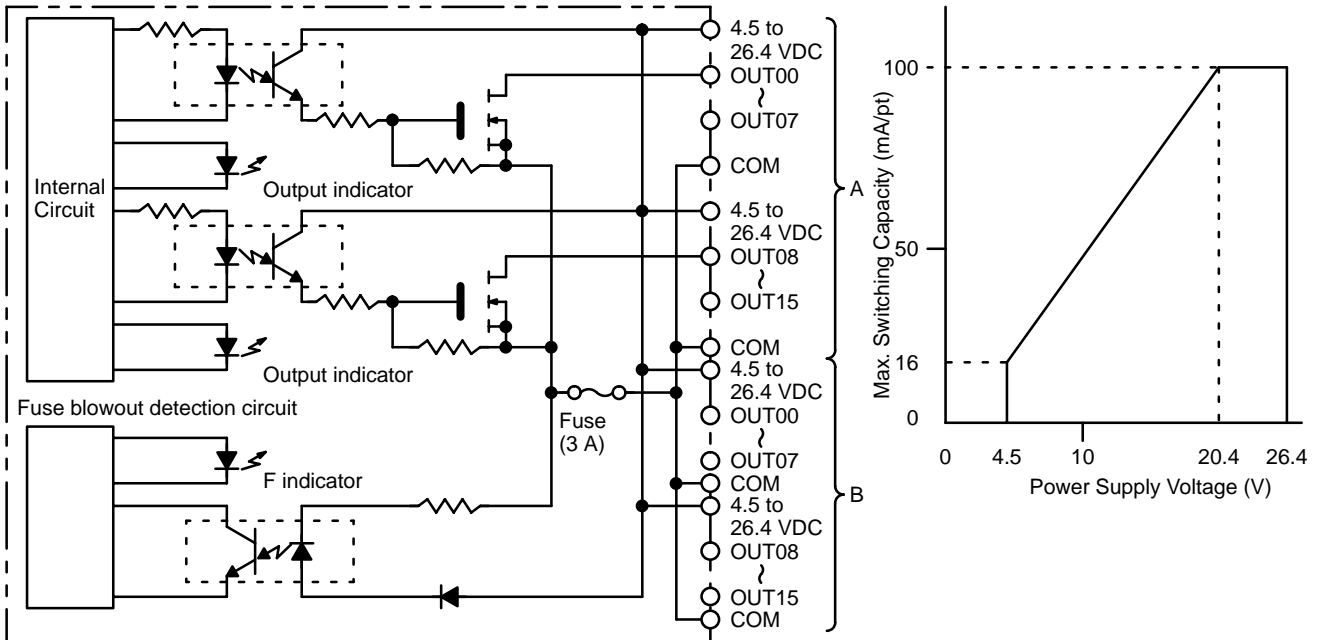

Terminal Connections

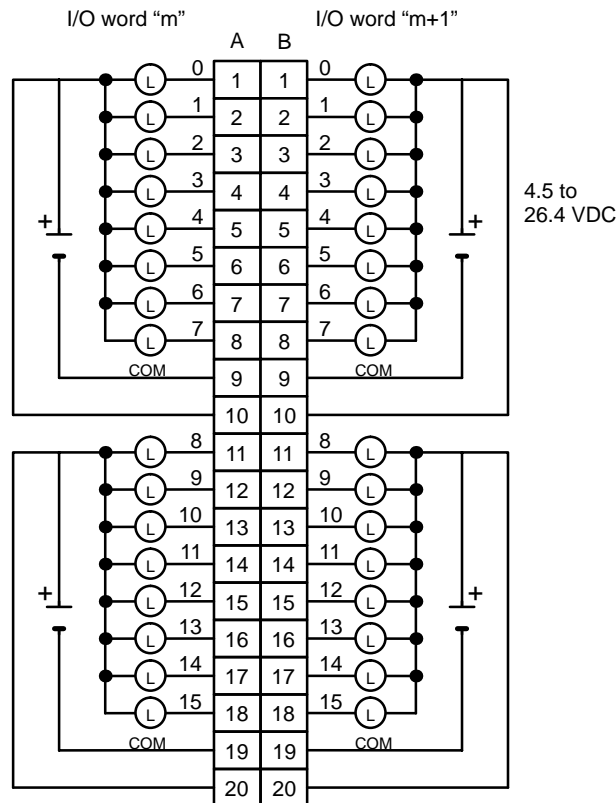

- Note**
1. I/O word "m" is determined by the I/O number setting ($m = IR\ 030 + 2 \times \text{I/O number}$).
 2. When the fuse blows, the F indicator lights and the error flag in AR 02 corresponding to the I/O number is turned ON. I/O numbers 0 to 9 correspond to AR 0205 to AR 0214.
 3. The interruption of power from the external power supply is treated the same as a fuse blowout.
 4. Connect power supply wiring to every COM terminal, even though the COM terminals are connected internally.

Transistor Output Unit C200H-OD219 (64 Points)

Max. Switching Capacity	16 mA 4.5 VDC to 100 mA 26.4 VDC (see below)
Min. Switching Capacity	None
Leakage Current	0.1 mA max.
Residual Voltage	0.8 V max.
ON Response Time	0.1 ms max.
OFF Response Time	0.4 ms max.
No. of Circuits	2 (32 points/common)
Internal Current Consumption	270 mA 5 VDC max.
Fuses	Two 3.5 A fuses (1 fuse/common) The fuses are not user-replacable.
Power for External Supply	220 mA 5 to 24 VDC $\pm 10\%$ min. (3.4 mA \times number of ON pts)
Weight	250 g max.
Dimensions	D-shape

Circuit Configuration

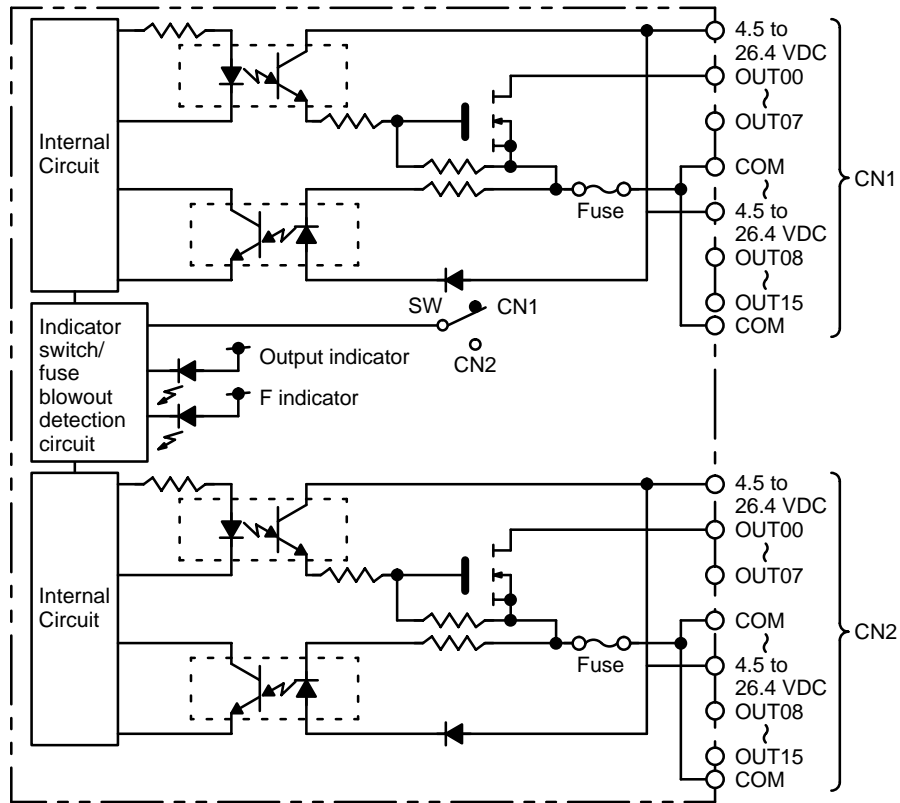

Maximum Switching Capacity

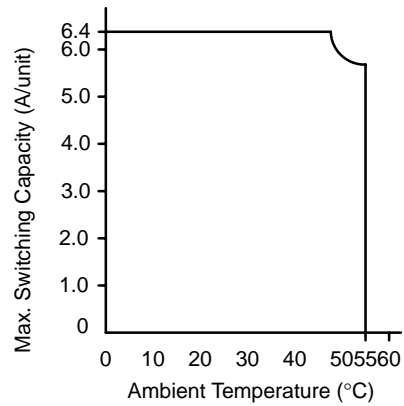
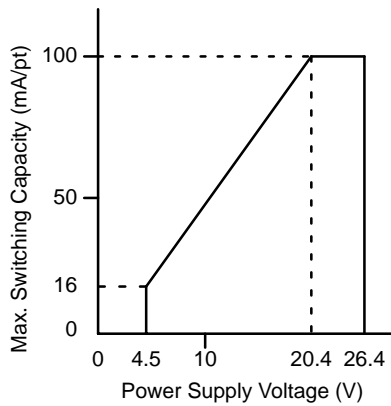

Terminal Connections



- Note**
1. I/O word "m" is determined by the I/O number setting ($m = IR\ 030 + 2 \times \text{I/O number}$).
 2. When either fuse blows, the F indicator lights and the error flag in AR 02 corresponding to the I/O number is turned ON. I/O numbers 0 to 9 correspond to AR 0205 to AR 0214.
 3. The interruption of power from the external power supply is treated the same as a fuse blowout.
 4. Connect power supply wiring to every COM terminal, even though the COM terminals in each connector are connected internally.

**Transistor Output Unit C200H-OD21B (32 Points)
(Load Short-circuit Protection Provided)**

Max. Switching Current	0.5 A 24 VDC ^{+10%} / _{-15%} (5 A/Unit)
Min. Switching Current	None
Leakage Current	0.1 mA max.
Residual Voltage	0.8 V max.
ON Response Time	0.1 ms max.
OFF Response Time	0.3 ms max.
No. of Circuits	32 (32 points/common)
Internal Current Consumption	180 mA 5 VDC max.
Fuses	One 7 A fuse (1 fuse/common) The fuses are not user-replacable.
Power for External Supply	160 mA 24 VDC ^{+10%} / _{-15%} min. (5 mA × number of ON pts)
Weight	180 g max.
Alarm Indicator	Lamp F lights (unless fuse is broken).
Load Short-circuit Prevention (see note 1)	Detection current: 0.7 to 2.5 A Automatic restart after error clearance.
Dimensions	C-shape

Note When the short-circuit/overload protection is activated for a contact point, the output for that point is turned OFF. At the same time, lamp “F” lights up, and the alarm from AR0205 to AR0214 corresponding to the I/O number turns ON. After the cause of the error has been removed, the alarm will be cleared automatically when the internal temperature of the element drops.

Circuit Configuration

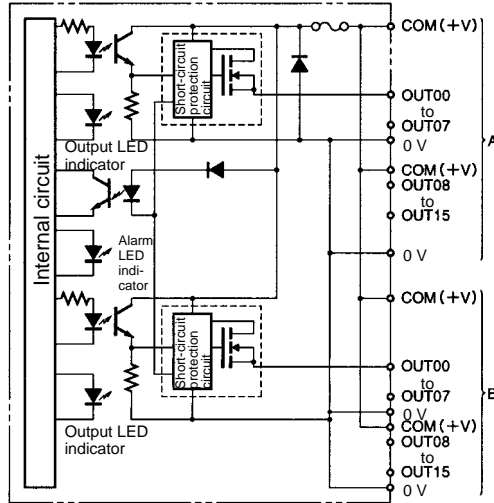

Terminal Connections

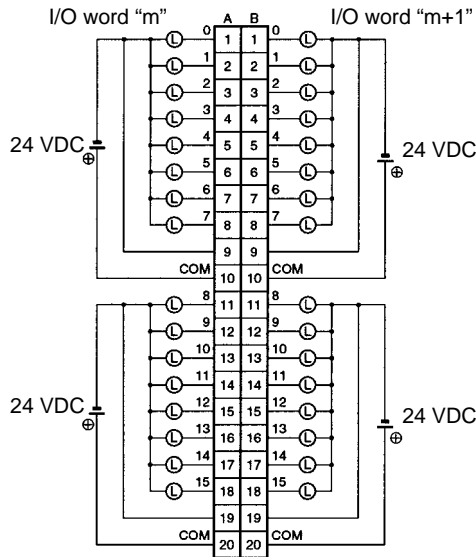

High-density I/O Units (Special I/O Units)

TTL Input Unit C200H-ID501 (32 Points)

Rated Input Voltage	5 VDC
Operating Input Voltage	4.5 to 5.5 VDC
Input Impedance	1.1 kΩ
Input Current	3.5 mA (at 5 VDC)
ON Voltage	3.0 VDC min.
OFF Voltage	1.0 VDC max.
ON Response Time	2.5 ms/15 ms max. (switchable; at 24 VDC, 25°C)
OFF Response Time	2.5 ms/15 ms max. (switchable; at 24 VDC, 25°C)
No. of Circuits	4 (8 points/common)
High-speed Inputs	8 points (connector 2 terminals 8 to 15, when set) Pulse width: 1 ms/4 ms min. (switchable)
Internal Current Consumption	130 mA 5 VDC max.
Weight	300 g max.
Dimensions	130×34.5×100.5 (H×W×D, in millimeters)

Circuit Configuration

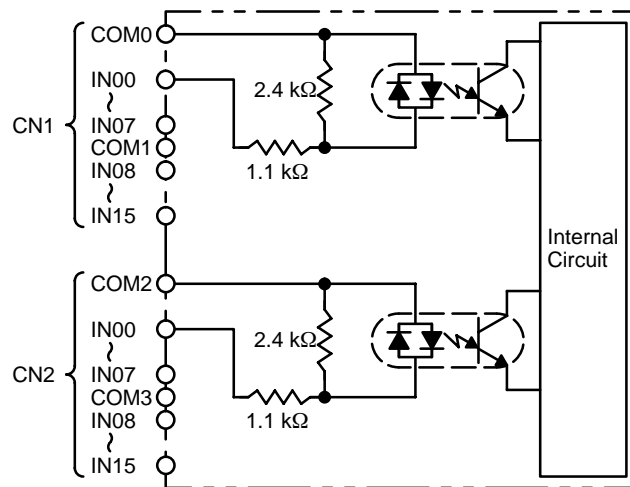

Terminal Connections

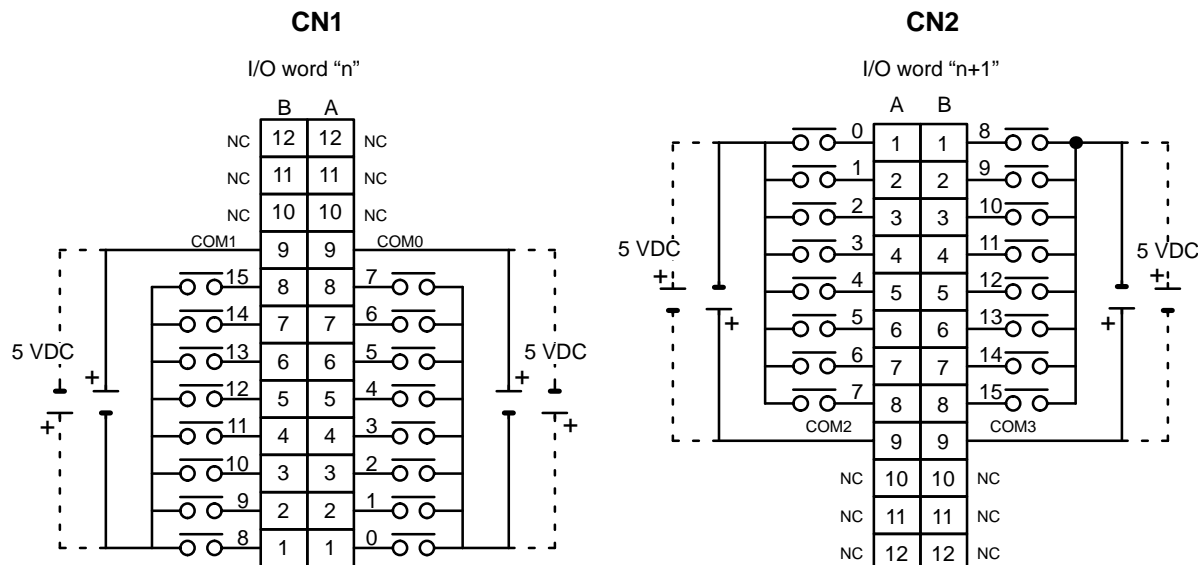

- Note**
1. I/O word "n" is determined by the unit number setting ($n = IR\ 100 + 10 \times \text{unit number}$).
 2. When pin 2 of the Unit's DIP switch is ON, input points 08 to 15 in connector 2 are high-speed inputs.

DC Input Unit C200H-ID215 (32 Points)

Rated Input Voltage	24 VDC
Operating Input Voltage	20.4 to 26.4 VDC
Input Impedance	5.6 kΩ
Input Current	4.1 mA (at 24 VDC)
ON Voltage	14.4 VDC min.
OFF Voltage	5.0 VDC max.
ON Response Time	2.5 ms/15 ms max. (switchable; at 24 VDC, 25°C)
OFF Response Time	2.5 ms/15 ms max. (switchable; at 24 VDC, 25°C)
No. of Circuits	4 (8 points/common)
High-speed Inputs	8 points (connector 2 terminals 8 to 15, when set) Pulse width: 1 ms/4 ms min. (switchable)
Internal Current Consumption	130 mA 5 VDC max.
Weight	300 g max.
Dimensions	130×34.5×100.5 (H×W×D, in millimeters)

Circuit Configuration

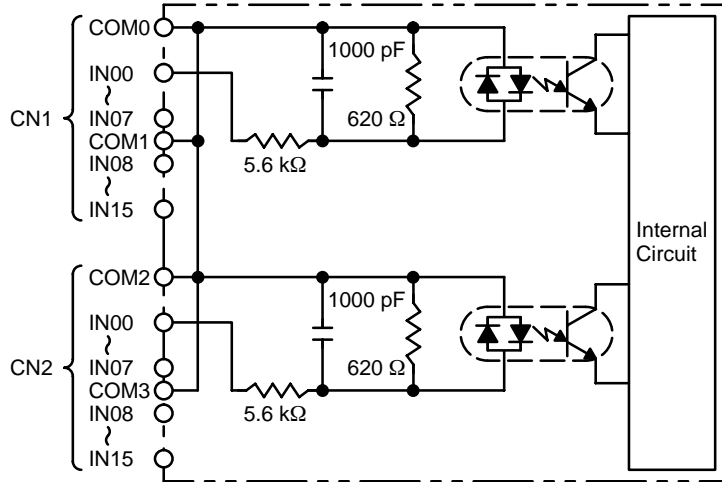

Terminal Connections

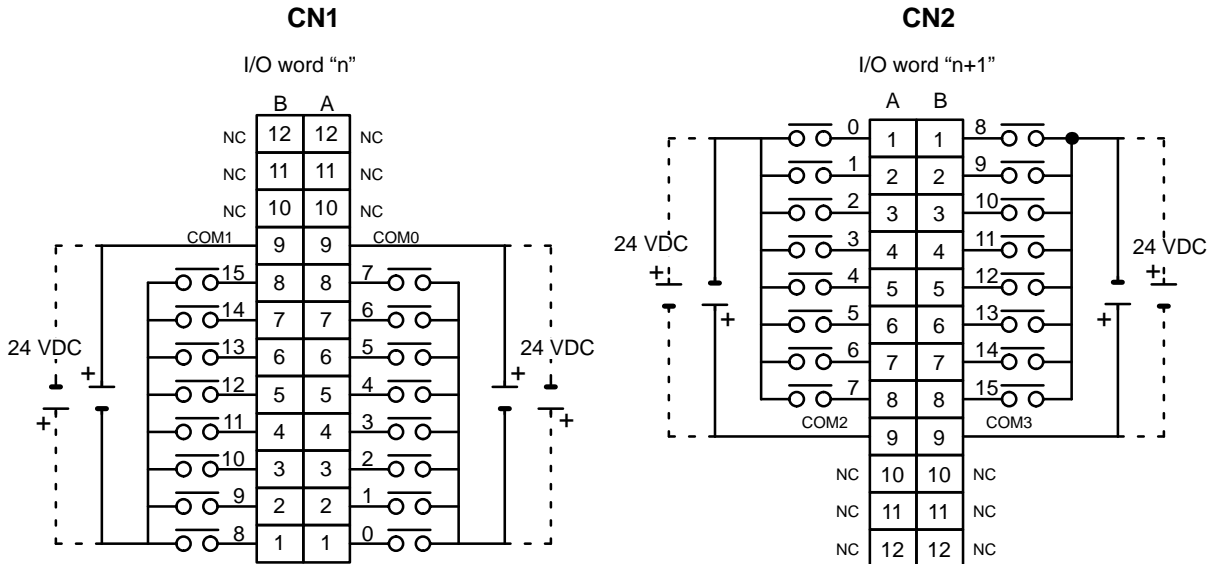

- Note**
1. I/O word "n" is determined by the unit number setting ($n = IR\ 100 + 10 \times \text{unit number}$).
 2. When pin 2 of the Unit's DIP switch is ON, input points 08 to 15 in connector 2 are high-speed inputs.
 3. At high temperatures, the number of inputs that can be turned ON simultaneously is limited. Refer to the graphs on page 172 for details.

TTL Output Unit C200H-OD501 (Used as a 32-point Output Unit)

Max. Switching Capacity	5 VDC 35 mA (280 mA/common, 1.12 A/Unit; output resistance 4.7 kΩ)
Min. Switching Capacity	None
Leakage Current	0.1 mA max.
Residual Voltage	0.4 V max.
ON Response Time	0.2 ms max.
OFF Response Time	0.3 ms max.
No. of Circuits	4 (8 points/common)
Internal Current Consumption	220 mA 5 VDC max.
Fuses	4 (1 fuse/common; fuses are not user-replacable.)
Power for External Supply	39 mA 5 VDC min. (1.2 mA × no. of outputs ON)
Weight	300 g max.
Dimensions	130×34.5×100.5 (H×W×D, in millimeters)

Circuit Configuration



Terminal Connections

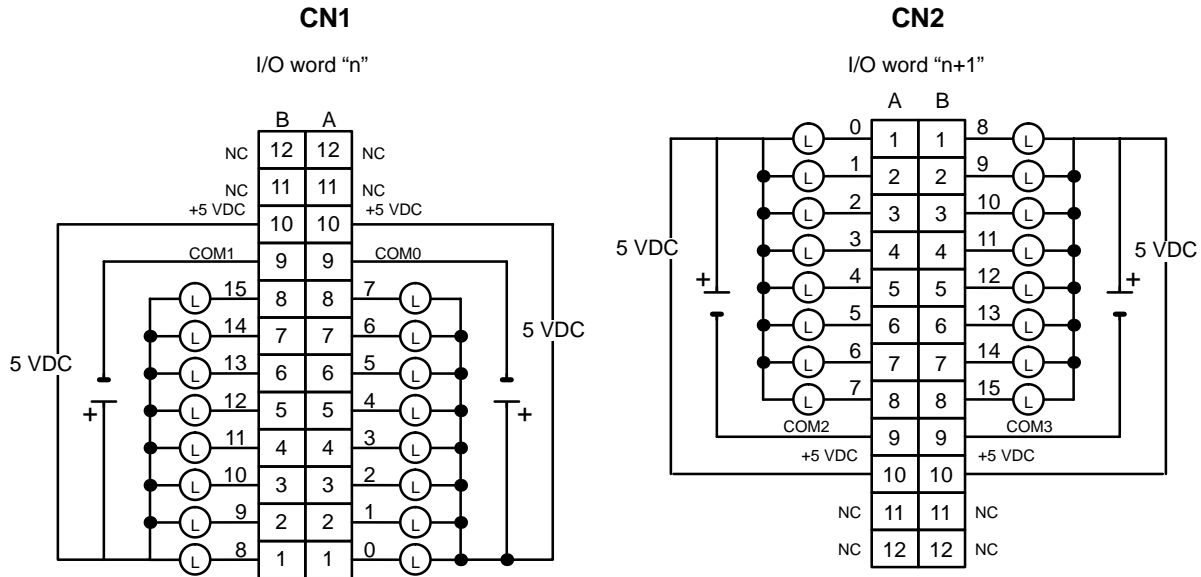

- Note**
1. I/O word “n” is determined by the unit number setting ($n = IR\ 100 + 10 \times \text{unit number}$).
 2. The Unit will have 32 static output points when pin 1 of it’s DIP switch is OFF.
 3. The outputs are negative logic outputs; when there is an output, the terminal has an “L” voltage level. Each output terminal has an output resistance of 4.7 kΩ.

TTL Output Unit C200H-OD501 (Used as 128-point Dynamic Output Unit)

Max. Switching Capacity	5 VDC 35 mA (280 mA/common, 1.12 A/Unit; output resistance 4.7 kΩ)
Min. Switching Capacity	None
Leakage Current	0.1 mA max.
Residual Voltage	0.4 V max.
ON Response Time	0.2 ms max.
OFF Response Time	0.3 ms max.
No. of Circuits	2 (dynamic, 64 points/circuit)
Internal Current Consumption	220 mA 5 VDC max.
Fuses	4 (1 fuse/common; fuses are not user-replacable.)
Power for External Supply	39 mA 5 VDC min. (1.2 mA × no. of outputs ON)
Weight	300 g max.
Dimensions	130×34.5×100.5 (H×W×D, in millimeters)

Circuit Configuration



Terminal Connections

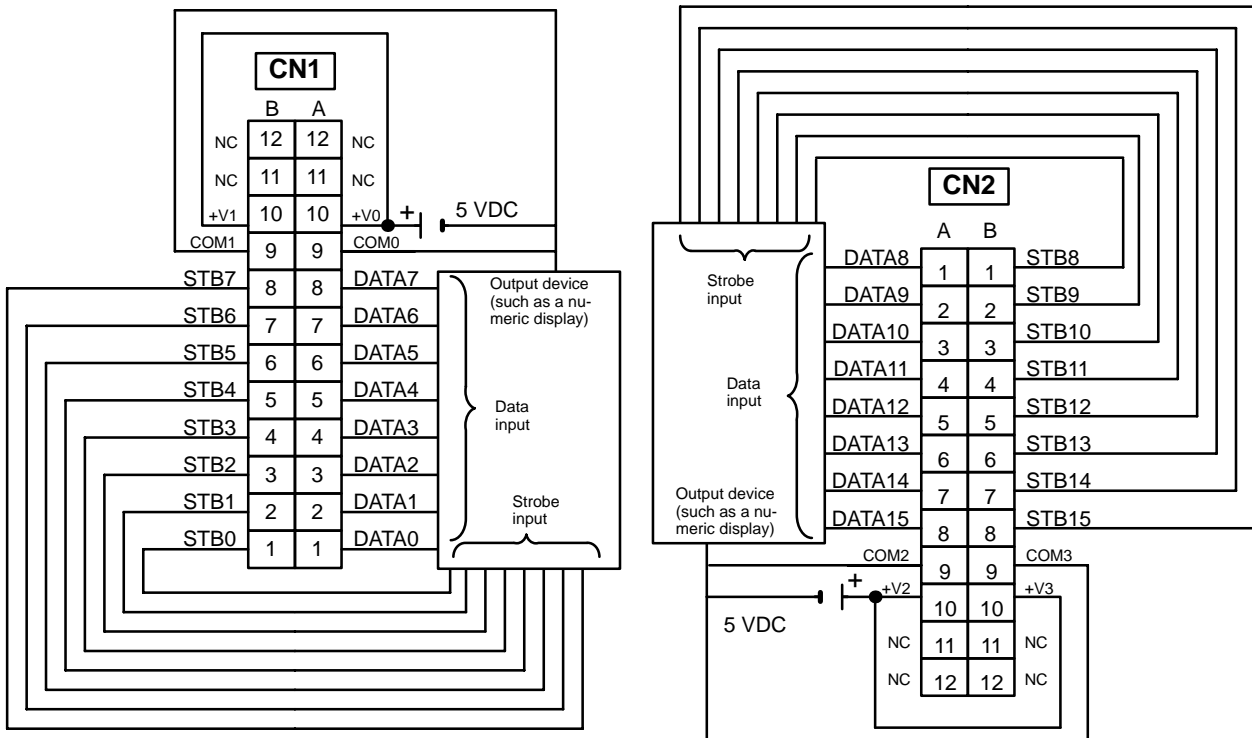

- Note**
1. Refer to the Unit's *Operation Manual* for details on I/O bit allocation.
 2. The Unit will have 128 dynamic output points when pin 1 of it's DIP switch is ON.
 3. Set pin 5 of the Unit's DIP switch ON for positive logic outputs, or OFF for negative logic outputs. When set for negative logic outputs, the terminal has an "L" voltage level when there is an output. When set for positive logic outputs, the terminal has an "H" voltage level when there is an output.
 4. The strobe signal has negative logic regardless of the setting of pin 5.

5. Each output terminal has an output resistance of 4.7 kΩ.

Transistor Output Unit C200H-OD215 (Used as 32-point Output Unit)

Max. Switching Capacity	16 mA 4.5 VDC to 100 mA 26.4 VDC (see page 172) 800 mA/common, 3.2 A/Unit
Min. Switching Capacity	None
Leakage Current	0.1 mA max.
Residual Voltage	0.7 V max.
ON Response Time	0.2 ms max.
OFF Response Time	0.6 ms max.
No. of Circuits	4 (8 points/common)
Internal Current Consumption	220 mA 5 VDC max.
Fuses	4 (1 fuse/common; fuses are not user-replacable.)
Power for External Supply	90 mA 5 to 24 VDC±10% min. (2.8 mA × number of ON outputs)
Weight	300 g max.
Dimensions	130×34.5×100.5 (H×W×D, in millimeters)

Circuit Configuration

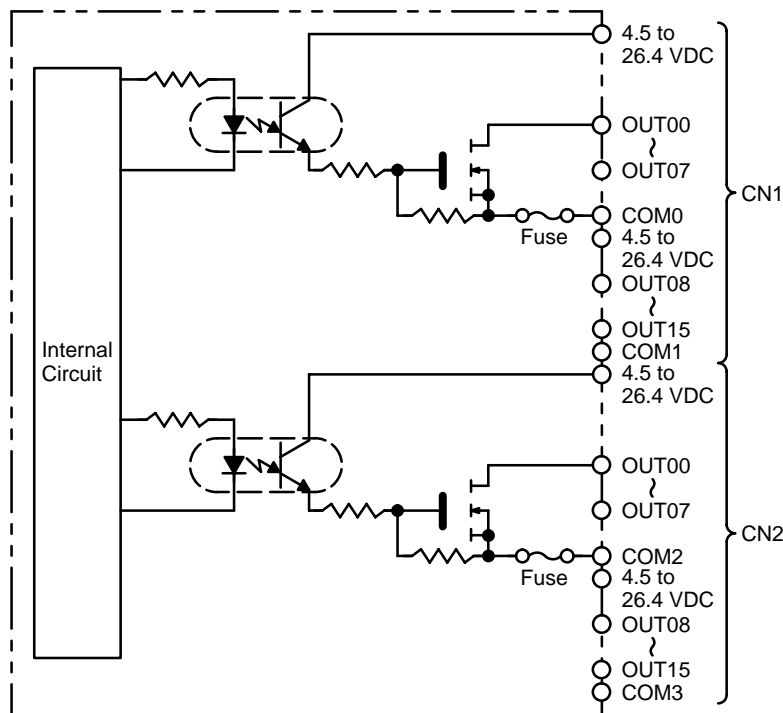

Terminal Connections

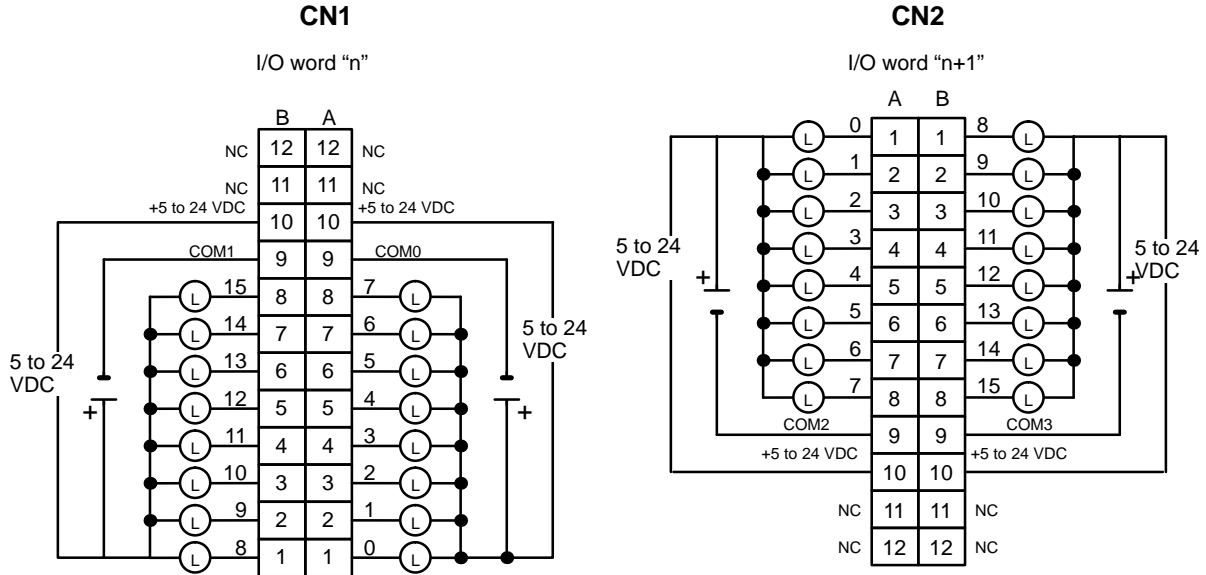

- Note**
1. I/O word "n" is determined by the unit number setting ($n = IR\ 100 + 10 \times \text{unit number}$).
 2. The Unit will have 32 static output points when pin 1 of it's DIP switch is OFF.

**Transistor Output Unit C200H-OD215
(Used as 128-point Dynamic Output Unit)**

Max. Switching Capacity	16 mA 4.5 VDC to 100 mA 26.4 VDC (see page 172) 800 mA/common, 3.2 A/Unit
Min. Switching Capacity	None
Leakage Current	0.1 mA max.
Residual Voltage	0.7 V max.
ON Response Time	0.2 ms max.
OFF Response Time	0.6 ms max.
No. of Circuits	2 (dynamic, 64 points/circuit)
Internal Current Consumption	220 mA 5 VDC max.
Fuses	4 (1 fuse/common; fuses are not user-replacable.)
Power for External Supply	90 mA 5 to 24 VDC $\pm 10\%$ min. (2.8 mA \times number of ON outputs)
Weight	300 g max.
Dimensions	130 \times 34.5 \times 100.5 (H \times W \times D, in millimeters)

Circuit Configuration



Terminal Connections

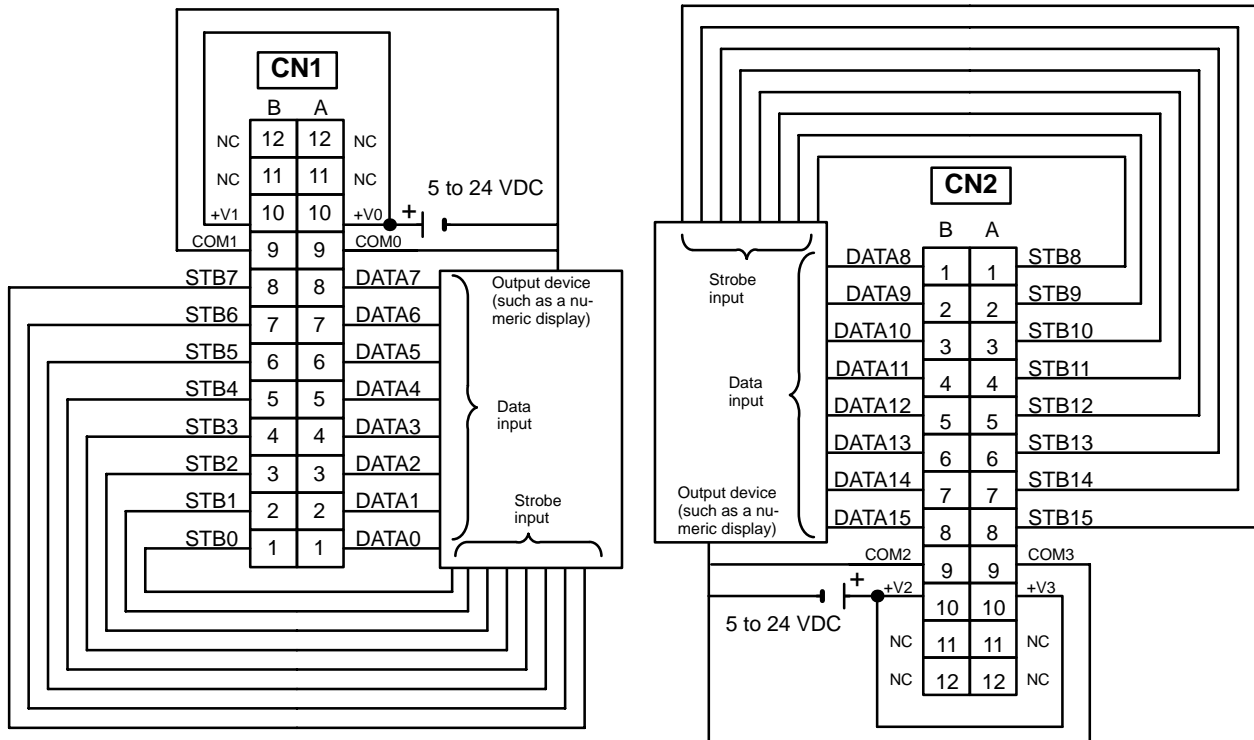

- Note**
1. Refer to the Unit's *Operation Manual* for details on I/O bit allocation.
 2. The Unit will have 128 dynamic output points when pin 1 of it's DIP switch is ON.
 3. Set pin 5 of the Unit's DIP switch ON for positive logic outputs, or OFF for negative logic outputs. When set for negative logic outputs, the terminal has an "L" voltage level when there is an output. When set for positive logic outputs, the terminal has an "H" voltage level when there is an output.

4. The strobe signal has negative logic regardless of the setting of pin 5.
5. When the output device (such as a numeric display) does not have a pull-up resistor, it is necessary to add a pull-up resistor between the + terminal of the power supply and each data (0 to 15) and strobe (0 to 15) terminal.

TTL I/O Unit C200H-MD501 (Used as I/O Unit with 16 Inputs and 16 Outputs)

Output Specifications (Connector 1)

Max. Switching Capacity	5 VDC 35 mA (280 mA/common, 560 mA/Unit; output resistance 4.7 kΩ)
Min. Switching Capacity	None
Leakage Current	0.1 mA max.
Residual Voltage	0.4 V max.
ON Response Time	0.2 ms max.
OFF Response Time	0.3 ms max.
No. of Circuits	2 (8 points/common)
Fuses	2 (1 fuse/common; fuses are not user-replacable.)
Power for External Supply	20 mA 5 VDC min. (1.2 mA × no. of outputs ON)

Input Specifications (Connector 2)

Rated Input Voltage	5 VDC
Operating Input Voltage	4.5 to 5.5 VDC
Input Impedance	1.1 kΩ
Input Current	3.5 mA (at 5 VDC)
ON Voltage	3.0 VDC min.
OFF Voltage	1.0 VDC max.
ON Response Time	2.5 ms/15 ms max. (switchable)
OFF Response Time	2.5 ms/15 ms max. (switchable)
No. of Circuits	2 (8 points/common)
High-speed Inputs	8 points (connector 2 terminals 8 to 15, when set) Pulse width: 1 ms/4 ms min. (switchable)

General Specifications

Internal Current Consumption	180 mA 5 VDC max.
Weight	300 g max.
Dimensions	130×34.5×100.5 (H×W×D, in millimeters)

Circuit Configuration

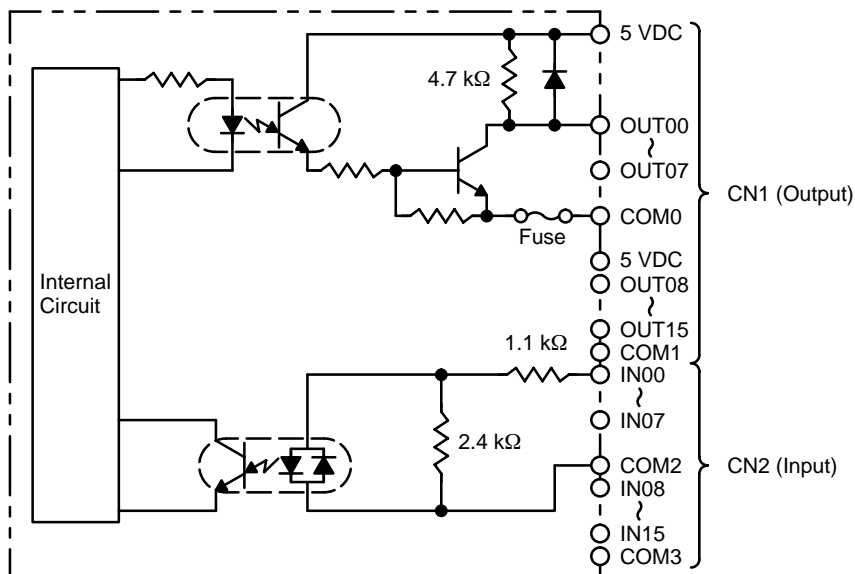

Terminal Connections



- Note**
1. I/O word "n" is determined by the unit number setting ($n = IR\ 100 + 10 \times \text{unit number}$).
 2. The Unit will have 16 static output and 16 static input points when pin 1 of its DIP switch is OFF.
 3. When pin 2 of the Unit's DIP switch is ON, input points 08 to 15 in connector 2 are high-speed inputs.
 4. The outputs are negative logic outputs; when there is an output, the terminal has an "L" voltage level. Each output terminal has an output resistance of 4.7 kΩ.
 5. The user is not authorized to change the fuse.

TTL I/O Unit C200H-MD501 (Used as 128-point Dynamic Input Unit)

Output Specifications (Connector 1)

Max. Switching Capacity	5 VDC 35 mA (280 mA/common, 560 mA/Unit; output resistance 4.7 kΩ)
Min. Switching Capacity	None
Leakage Current	0.1 mA max.
Residual Voltage	0.4 V max.
ON Response Time	0.2 ms max.
OFF Response Time	0.3 ms max.
Fuses	2 (1 fuse/common; fuses are not user-replacable.)
Power for External Supply	20 mA 5 VDC min. (1.2 mA × no. of outputs ON)

Input Specifications (Connector 2)

Rated Input Voltage	5 VDC
Operating Input Voltage	4.5 to 5.5 VDC
Input Impedance	1.1 kΩ
Input Current	3.5 mA (at 5 VDC)
ON Voltage	3.0 VDC min.
OFF Voltage	1.0 VDC max.

General Specifications

No. of Circuits	2 (dynamic, 64 points/circuit)
Internal Current Consumption	180 mA 5 VDC max.
Weight	300 g max.
Dimensions	130×34.5×100.5 (H×W×D, in millimeters)

Circuit Configuration

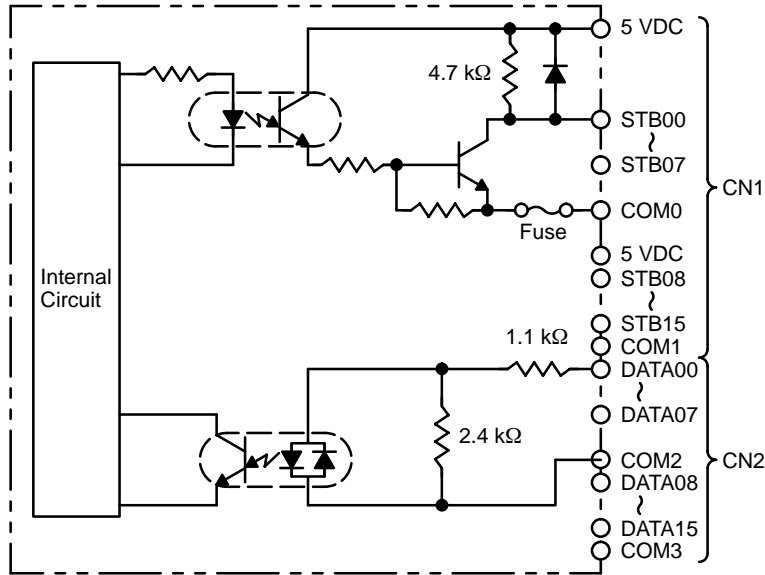

Terminal Connections

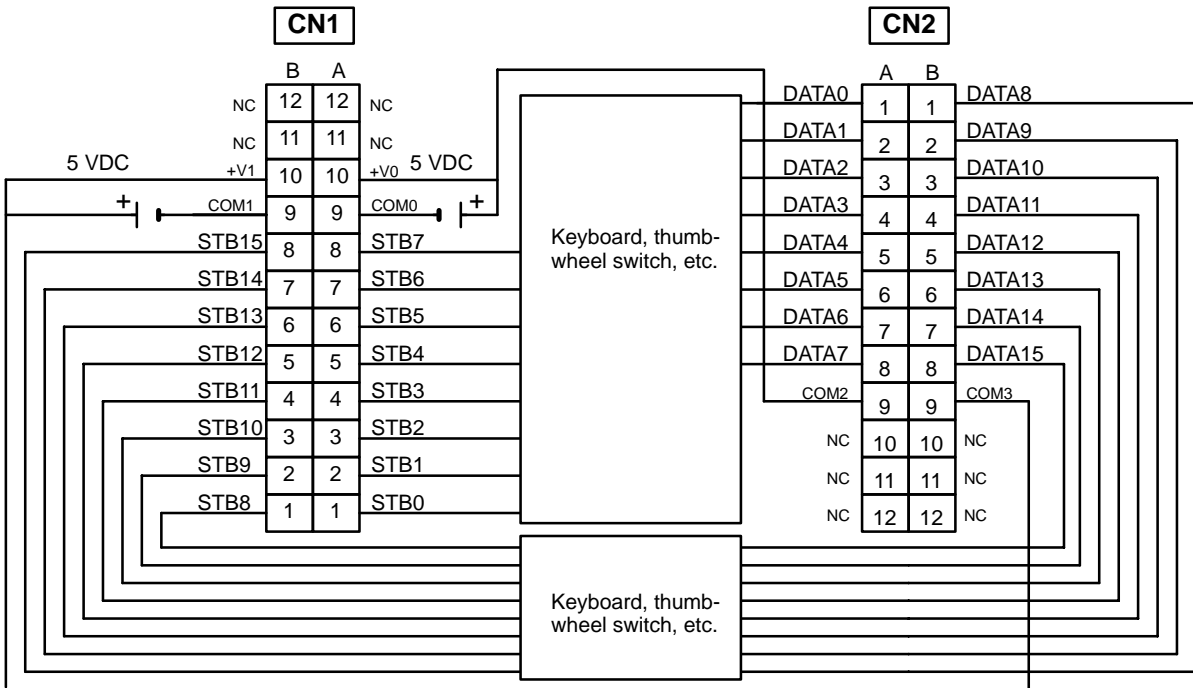

- Note**
1. Refer to the Unit's *Operation Manual* for details on I/O bit allocation.
 2. The Unit will have 128 dynamic output points when pin 1 of it's DIP switch is ON.
 3. Each output terminal has an output resistance of 4.7 kΩ.

12 VDC Input/Transistor Output Unit C200H-MD115 (Used as I/O Unit with 16 Inputs and 16 Outputs)

Output Specifications (Connector 1)

Max. Switching Capacity	16 mA 4.5 VDC to 100 mA 26.4 VDC (see page 172), 800 mA/common, 1.6 A/Unit
Min. Switching Capacity	None
Leakage Current	0.1 mA max.
Residual Voltage	0.7 V max.
ON Response Time	0.2 ms max.
OFF Response Time	0.6 ms max.
No. of Circuits	2 (8 points/common)
Fuses	2 (1 fuse/common; fuses are not user-replacable.)
Power for External Supply	45 mA 5 to 24 VDC±10% min. (2.8 mA × number of ON outputs)

Input Specifications (Connector 2)

Rated Input Voltage	12 VDC +10%/−15%
Operating Input Voltage	10.2 to 13.2 VDC
Input Impedance	2.7 kΩ
Input Current	4.1 mA (at 12 VDC)
ON Voltage	8.0 VDC min.
OFF Voltage	3.0 VDC max.
ON Response Time	2.5 ms/15 ms max. (switchable)
OFF Response Time	2.5 ms/15 ms max. (switchable)
No. of Circuits	2 (8 points/common)
High-speed Inputs	8 points (connector 2 terminals 8 to 15, when set) Pulse width: 1 ms/4 ms min. (switchable)

General Specifications

Internal Current Consumption	180 mA 5 VDC max.
Weight	300 g max.
Dimensions	130×34.5×100.5 (H×W×D, in millimeters)

Circuit Configuration

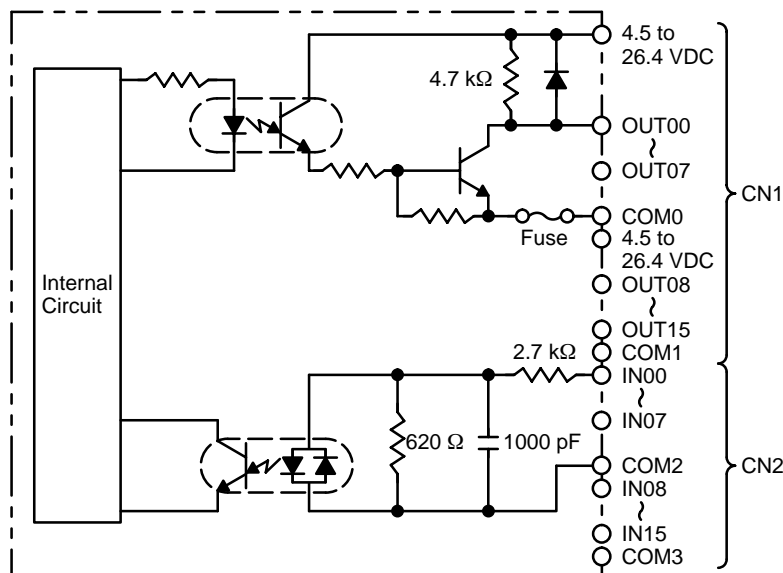

Terminal Connections

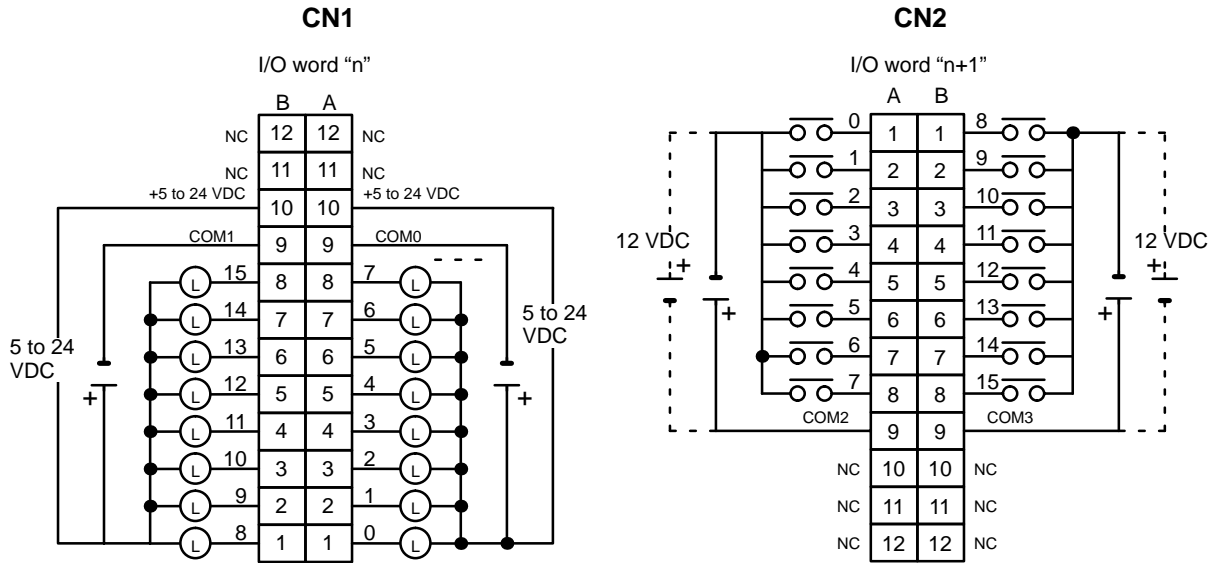

- Note**
1. I/O word "n" is determined by the unit number setting ($n = IR\ 100 + 10 \times \text{unit number}$).
 2. The Unit will have 16 static output and 16 static input points when pin 1 of its DIP switch is OFF.
 3. When pin 2 of the Unit's DIP switch is ON, input points 08 to 15 in connector 2 are high-speed inputs.

**12 VDC Input/Transistor Output Unit C200H-MD115
(Used as 128-point Dynamic Input Unit)**

**Output Specifications
(Connector 1)**

Max. Switching Capacity	50 mA 12 VDC, 400 mA/common, 0.8 A/Unit
Min. Switching Capacity	None
Leakage Current	0.1 mA max.
Residual Voltage	0.7 V max.
ON Response Time	0.2 ms max.
OFF Response Time	0.6 ms max.
Fuses	2 (1 fuse/common; fuses are not user-replacable.)
Power for External Supply	45 mA 5 to 24 VDC ±10% min. (2.8 mA × number of ON outputs)

**Input Specifications
(Connector 2)**

Rated Input Voltage	12 VDC
Operating Input Voltage	10.2 to 13.2 VDC
Input Impedance	2.7 kΩ
Input Current	4.1 mA (at 12 VDC)
ON Voltage	8.0 VDC min.
OFF Voltage	3.0 VDC max.

General Specifications

No. of Circuits	2 (dynamic, 64 points/circuit)
Internal Current Consumption	180 mA 5 VDC max.
Weight	300 g max.
Dimensions	130×34.5×100.5 (H×W×D, in millimeters)

Circuit Configuration

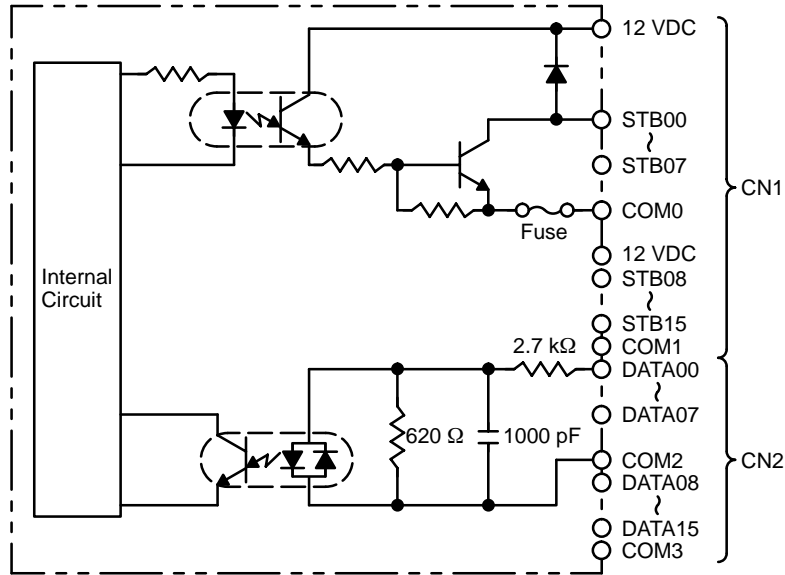

Terminal Connections

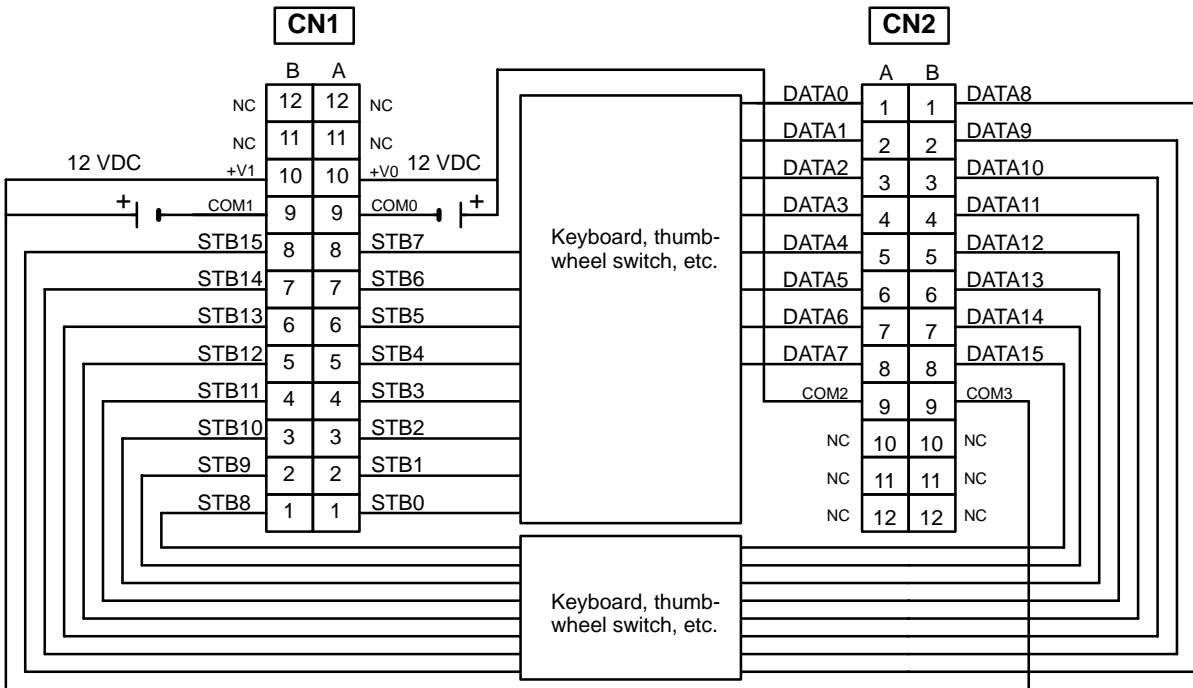

- Note**
1. Refer to the Unit's *Operation Manual* for details on I/O bit allocation.
 2. The Unit will have 128 dynamic output points when pin 1 of it's DIP switch is ON.

24 VDC Input/Transistor Output Unit C200H-MD215 (Used as I/O Unit with 16 Inputs and 16 Outputs)

Output Specifications (Connector 1)

Max. Switching Capacity	16 mA 4.5 VDC to 100 mA 26.4 VDC (see page 172), 800 mA/common, 1.6 A/Unit
Min. Switching Capacity	None
Leakage Current	0.1 mA max.
Residual Voltage	0.7 V max.
ON Response Time	0.2 ms max.
OFF Response Time	0.6 ms max.
No. of Circuits	2 (8 points/common)
Fuses	2 (1 fuse/common; fuses are not user-replacable.)
Power for External Supply	45 mA 5 to 24 VDC \pm 10% min. (2.8 mA \times number of ON outputs)

Input Specifications (Connector 2)

Rated Input Voltage	24 VDC
Operating Input Voltage	20.4 to 26.4 VDC
Input Impedance	5.6 k Ω
Input Current	4.1 mA (at 24 VDC)
ON Voltage	14.4.0 VDC min.
OFF Voltage	5.0 VDC max.
ON Response Time	2.5 ms/15 ms max. (switchable)
OFF Response Time	2.5 ms/15 ms max. (switchable)
No. of Circuits	2 (8 points/common)
High-speed Inputs	8 points (connector 2 terminals 8 to 15, when set) Pulse width: 1 ms/4 ms min. (switchable)

General Specifications

Internal Current Consumption	180 mA 5 VDC max.
Weight	300 g max.
Dimensions	130 \times 34.5 \times 100.5 (H \times W \times D, in millimeters)

Circuit Configuration

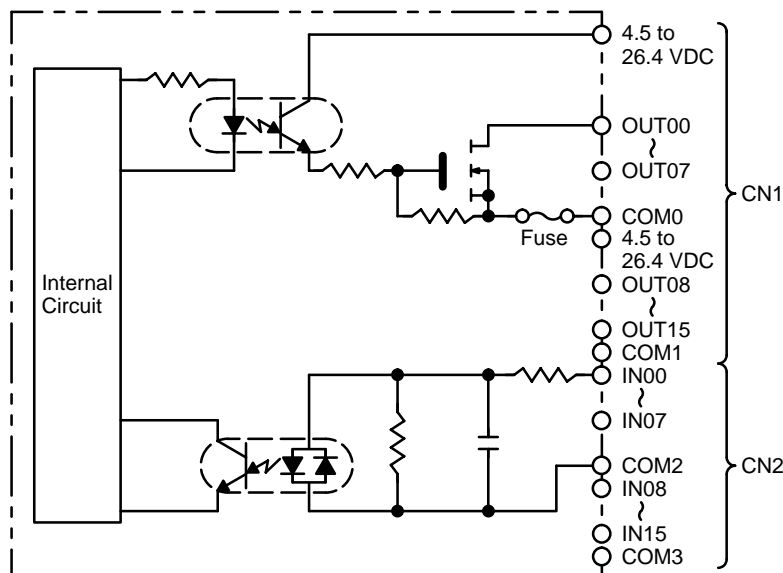

Terminal Connections



- Note**
1. I/O word "n" is determined by the unit number setting ($n = IR\ 100 + 10 \times \text{unit number}$).
 2. The Unit will have 16 static output and 16 static input points when pin 1 of it's DIP switch is OFF.
 3. At high temperatures, the number of inputs that can be turned ON simultaneously is limited. Refer to the graph on page 172 for details.
 4. When pin 2 of the Unit's DIP switch is ON, input points 08 to 15 in connector 2 are high-speed inputs.

**24 VDC Input/Transistor Output Unit C200H-MD215
(Used as 128-point Dynamic Input Unit)**

**Output Specifications
(Connector 1)**

Max. Switching Capacity	100 mA 24 VDC, 800 mA/common, 1.6 A/Unit
Min. Switching Capacity	None
Leakage Current	0.1 mA max.
Residual Voltage	0.7 V max.
ON Response Time	0.2 ms max.
OFF Response Time	0.6 ms max.
Fuses	2 (1 fuse/common; fuses are not user-replacable.)
Power for External Supply	45 mA 5 to 24 VDC ±10% min. (2.8 mA × number of ON outputs)

**Input Specifications
(Connector 2)**

Rated Input Voltage	24 VDC
Operating Input Voltage	20.4 to 26.4 VDC
Input Impedance	5.6 kΩ
Input Current	4.1 mA (at 24 VDC)
ON Voltage	14.4.0 VDC min.
OFF Voltage	5.0 VDC max.

General Specifications

No. of Circuits	2 (dynamic, 64 points/circuit)
Internal Current Consumption	180 mA 5 VDC max.
Weight	300 g max.
Dimensions	130×34.5×100.5 (H×W×D, in millimeters)

Circuit Configuration

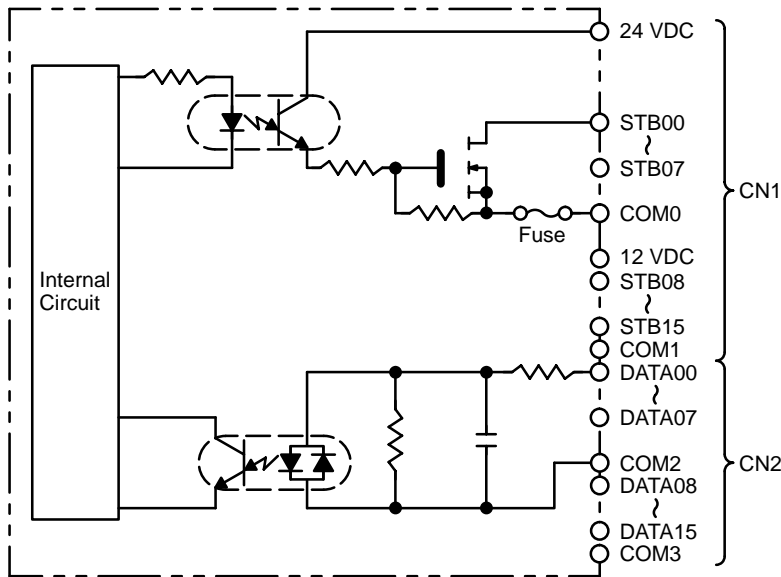

Terminal Connections

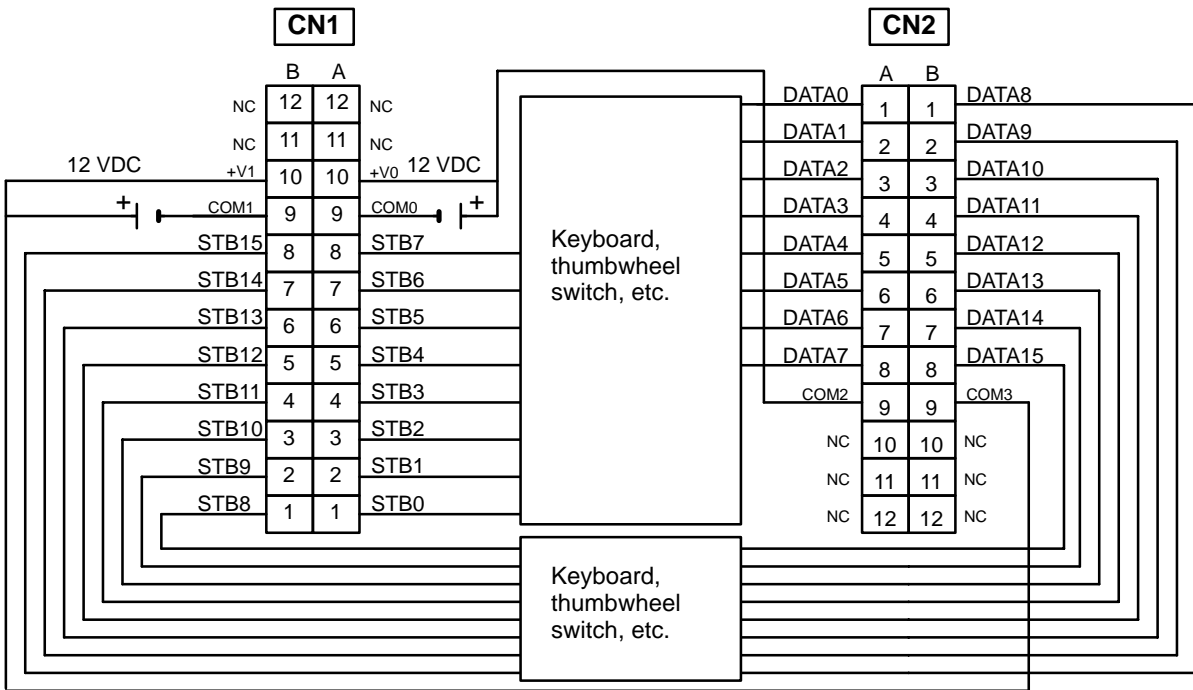

- Note**
1. Refer to the Unit's *Operation Manual* for details on I/O bit allocation.
 2. The Unit will have 128 dynamic output points when pin 1 of it's DIP switch is ON.
 3. Each output terminal has an output resistance of 4.7 kΩ.
 4. At high temperatures, the number of inputs that can be turned ON simultaneously is limited. Refer to the graph on page 172 for details.
 5. The user is not authorized to change the fuse.

High-density I/O Unit Limitations

Limitations on the switching capacity of C200H-OD215/MD115/MD215 Transistor Output Units and the usable number of I/O points in the C200H-ID215 and C200H-MD215 are shown below.

Switching Capacity

The switching capacity of C200H-OD215/MD115/MD215 Transistor Output Units depends on the power supply voltage, as shown below.



Usable I/O Points (C200H-ID215)

To prevent overheating in the C200H-ID215 that can cause early failure of internal components, limit the number of input points that are ON simultaneously. As shown below, the number of points that can be on simultaneously depends on both the temperature and the input voltage.

For example, 22 pts with input voltage of 24.0 VDC can be ON at 55°C, but only 16 pts with input voltage of 26.4 VDC can be ON at 55°C. At 24.0 VDC, all 32 input pts can be ON up to 43°C, but at 26.4 VDC all 32 input pts can be ON up to 34°C.



Note If the Unit is at room temperature it takes about 10 minutes for excessive heat to build up when all inputs are turned ON, so all inputs can be turned ON simultaneously for testing.

Usable I/O Points (C200H-MD215)

To prevent overheating in the C200H-MD215 and prevent early failure of internal components, limit the number of input points ON simultaneously. The number of points that can be on simultaneously depends on both the temperature and the input voltage. (There is no limit to the number of output points that can be ON simultaneously.)

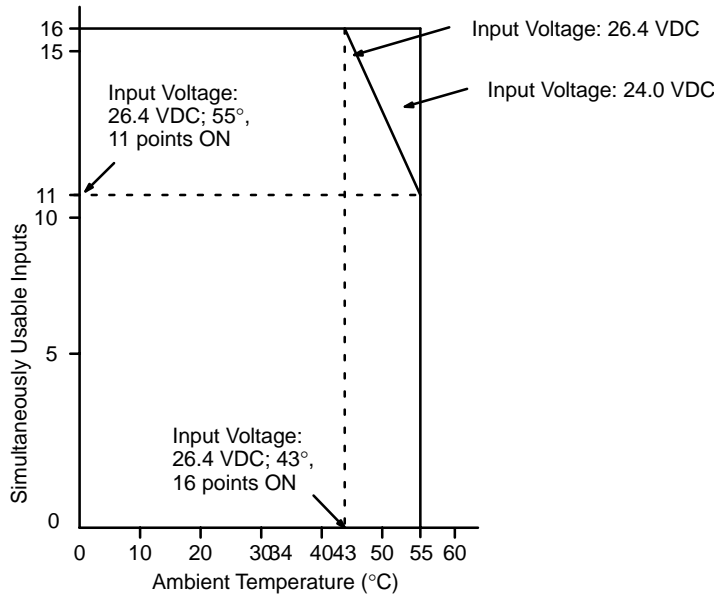

Note If the Unit is at room temperature it takes about 10 minutes for excessive heat to build up when all inputs are turned ON, so all inputs can be turned ON simultaneously for testing.

High-density I/O Unit (Special I/O Unit) DIP Switch

Any unused pin can be set to either ON or OFF.

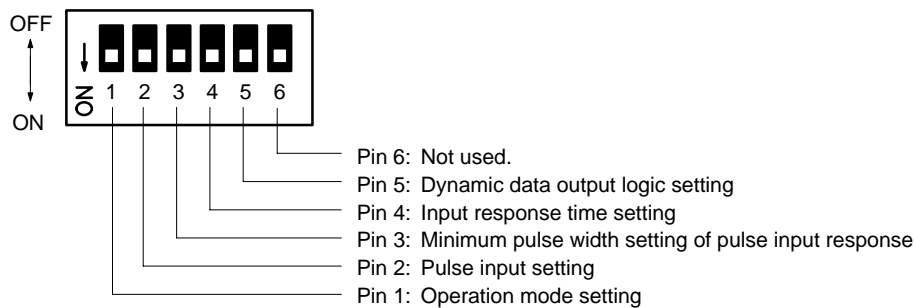

Pin 1: Operation Mode Setting

Pin 1 is not used for the C200H-ID501 or C200H-ID215.

Pin 1	C200H-OD501/215	C200H-MD501/115/215
OFF	32-point static output mode	16-/16-point output static mode
ON	128-point dynamic output mode	128-point dynamic input mode

Pin 2: Pulse Input Setting

Use pin 2 only for the C200H-ID501, C200H-ID215, C200H-MD501, C200H-MD115, and C200H-MD215. The C200H-MD501, C200H-MD115, and C200H-MD215 pin 2 settings are effective in static mode only (i.e., pin 1 is set to OFF).

When this pin is set for pulse inputs, only inputs 08 to 15 of CN2 will be pulse inputs. The response time of any other input regarded as a normal input is set according to the input response time setting with pin 4.

Pin 2	Function
OFF	Normal input
ON	Pulse input

Pin 3: Minimum Pulse Width Setting of Pulse Input Response

Use pin 3 only when pin 2 of the C200H-ID501, C200H-ID215, C200H-MD501, C200H-MD115, and C200H-MD215 is set to ON (i.e., when pulse input is set).

Pin 3	Minimum response input pulse width
OFF	1 ms
ON	4 ms

Pin 4: Input Response Time Setting

Use pin 4 for the C200H-ID501, C200H-ID215, C200H-MD501, C200H-MD115, and C200H-MD215 only.

Pin 4	Input response time
OFF	2.5 ms max.
ON	15 ms max.

Pin 5: Dynamic Data Output Logic Setting

Use pin 5 only when the C200H-OD501 or C200H-OD215 is in dynamic output mode (i.e., when pin 1 is set to ON).

Pin 5	Data output
OFF	Negative logic output
ON	Positive logic output

DIP Switch Settings for High-density I/O Unit (Special I/O Unit)

Model	Pin 1	Pin 2	Pin 3	Pin 4	Pin 5	Pin 6
C200H-ID501/215	Setting is not required	Must be set	Set when pulse input is used	Must be set	Setting is not required	Setting is not required
C200H-OD501/215	OFF	Setting is not required	Setting is not required	Setting is not required	Setting is not required	Setting is not required
	ON	Setting is not required	Setting is not required	Setting is not required	Must be set	Setting is not required
C200H-MD501/115/215	OFF	Must be set	Set when pulse input is used	Must be set	Setting is not required	Setting is not required
	ON	Setting is not required	Setting is not required	Setting is not required	Setting is not required	Setting is not required

Analog Timer Unit C200H-TM001

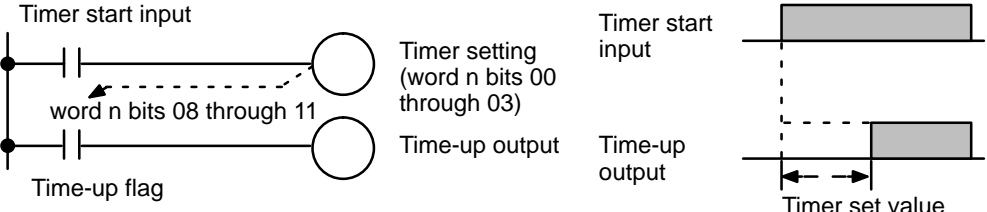
Item	Specifications																															
Oscillation Method	CR oscillation																															
Time Setting Range	Use the DIP switch to set any of the following four ranges, according to the chart shown on the next page. 0.1 to 1 second (typical) 1 to 10 seconds (typical) 10 to 60 seconds (typical) 1 to 10 minutes (typical)																															
Timer Pause Function	The timing operation can be paused if so specified by the program. Therefore, the timers can also be used as cumulative registers.																															
Number of Timer Points	4																															
Indicators	SET and TIME UP																															
External Variable Resistor	External variable resistors can be used to set the time value when the IN/EXT selector is set to OFF (EXT). Use 20 kΩ variable resistors.																															
Bit Allocation	<p>The word is determined by the system configuration.</p> <table border="1" data-bbox="454 646 774 1428"> <thead> <tr> <th>Bit</th> <th>Function</th> </tr> </thead> <tbody> <tr><td>00</td><td>T0 start output</td></tr> <tr><td>01</td><td>T1 start output</td></tr> <tr><td>02</td><td>T2 start output</td></tr> <tr><td>03</td><td>T3 start output</td></tr> <tr><td>04</td><td>T0 pause output</td></tr> <tr><td>05</td><td>T1 pause output</td></tr> <tr><td>06</td><td>T2 pause output</td></tr> <tr><td>07</td><td>T3 pause output</td></tr> <tr><td>08</td><td>T0 time-up input</td></tr> <tr><td>09</td><td>T1 time-up input</td></tr> <tr><td>10</td><td>T2 time-up input</td></tr> <tr><td>11</td><td>T3 time-up input</td></tr> <tr><td>12</td><td rowspan="4">Cannot be used</td></tr> <tr><td>13</td></tr> <tr><td>14</td></tr> <tr><td>15</td></tr> </tbody> </table> <p> "1" when time is running 0 Operates 1 Stops "1" when time is up </p>	Bit	Function	00	T0 start output	01	T1 start output	02	T2 start output	03	T3 start output	04	T0 pause output	05	T1 pause output	06	T2 pause output	07	T3 pause output	08	T0 time-up input	09	T1 time-up input	10	T2 time-up input	11	T3 time-up input	12	Cannot be used	13	14	15
Bit	Function																															
00	T0 start output																															
01	T1 start output																															
02	T2 start output																															
03	T3 start output																															
04	T0 pause output																															
05	T1 pause output																															
06	T2 pause output																															
07	T3 pause output																															
08	T0 time-up input																															
09	T1 time-up input																															
10	T2 time-up input																															
11	T3 time-up input																															
12	Cannot be used																															
13																																
14																																
15																																
Programming and Timing Chart	 <p> Timer start input Timer setting (word n bits 00 through 03) word n bits 08 through 11 Time-up flag Time-up output Timer set value </p>																															
Internal Current Consumption	60 mA 5 VDC max.																															

Internal variable resistors

These variable resistors are used to set the timers. The settings of these resistors are effective only when the corresponding IN/EXT selector is ON. To set or adjust the time, use the screwdriver supplied with the Unit. Turn the variable resistor clockwise to increase the time value. The numbers 0 through 3 correspond to T0 through T3, respectively.

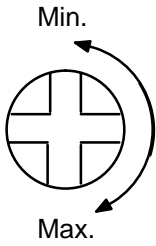

Indicators

The SET indicators in the top row light when the corresponding timer is operating. The TIME UP indicators in the bottom row light when the corresponding timer (T0 through T3) turns ON.

Time range setting

External variable resistor connectors

External variable resistors can also be used to set the timers. The IN/EXT selector pin must be set to the OFF position. Numbers 0 through 3 correspond to T0 through T3, respectively. Use 20-kΩ variable resistors and AWG 22 to 28 lead wires. The connector has solderless terminals and must be wired as shown below.

IN/EXT selectors

When the internal variable resistor is used, set the corresponding pin to ON; when an external variable resistor is used, set the corresponding pin to OFF. Pin numbers 4 through 1 correspond to T0 through T3, respectively.

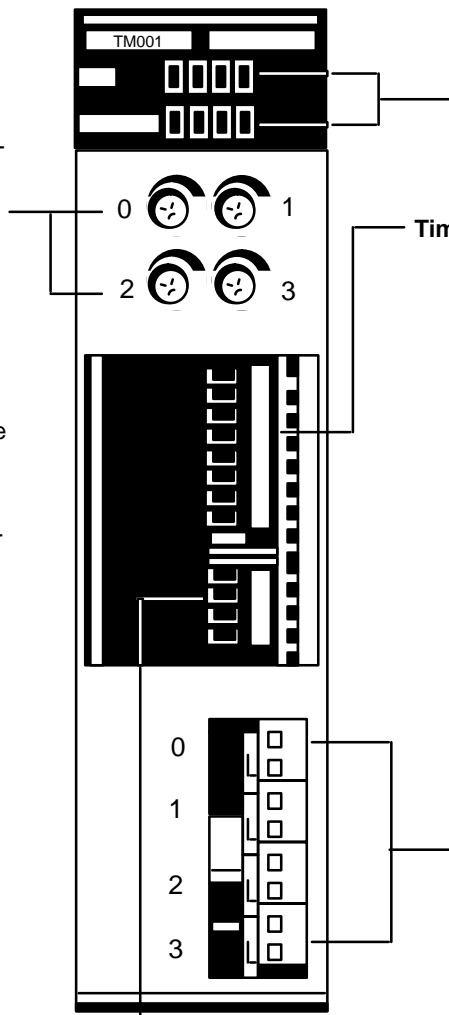

Timers	Pin	0.1 to 1 s	0.1 to 10 s	10 to 60 s	1 to 10 m
T0	8	0	1	0	1
	7	0	0	1	1
T1	6	0	1	0	1
	5	0	0	1	1
T2	4	0	1	0	1
	3	0	0	1	1
T3	2	0	1	0	1
	1	0	0	1	1

(0: OFF 1: ON)

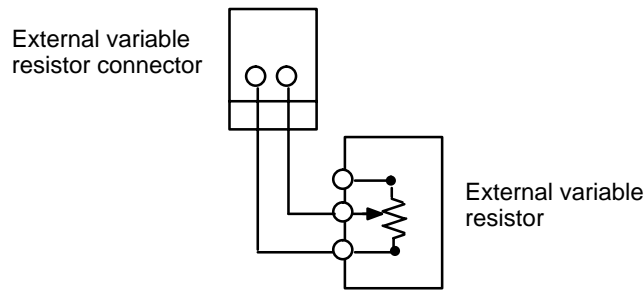

Caution Ensure that the external variable resistor connectors are open when using the internal variable resistor.

Standard B7A Interface Unit C200H-B7A11/B7A01

The Standard B7A Interface Unit used with the B7A Link Terminal allows the transmission and reception of 16-point I/O data over two wires.

The following Standard B7A Interface Unit and B7A Link Terminal models are available.

B7A Interface Unit	B7A Link Terminals
16-point input: C200H-B7A11	B7A-T6□1 (Screw terminal models) B7A-T6D2 (Modular models)
16-point output: C200H-B7A01	B7A-R6□□1 (Screw terminal models) B7A-R6A52 (Modular models)

Mount the B7A Interface Unit to the C200H-BC□□1-V1 or C200H-BC□□1-V2 Backplane.

Note If the B7A Interface Unit is connected to the C200HS-CPU03/CPU23-E/CPU33-E or C200H-PS211, supply 24 VDC from an independent power supply to the B7A Interface Unit or use a transformer to separate the power supply line to the B7A Interface Unit from the power supply lines to the CPU and I/O Power Supply Unit.

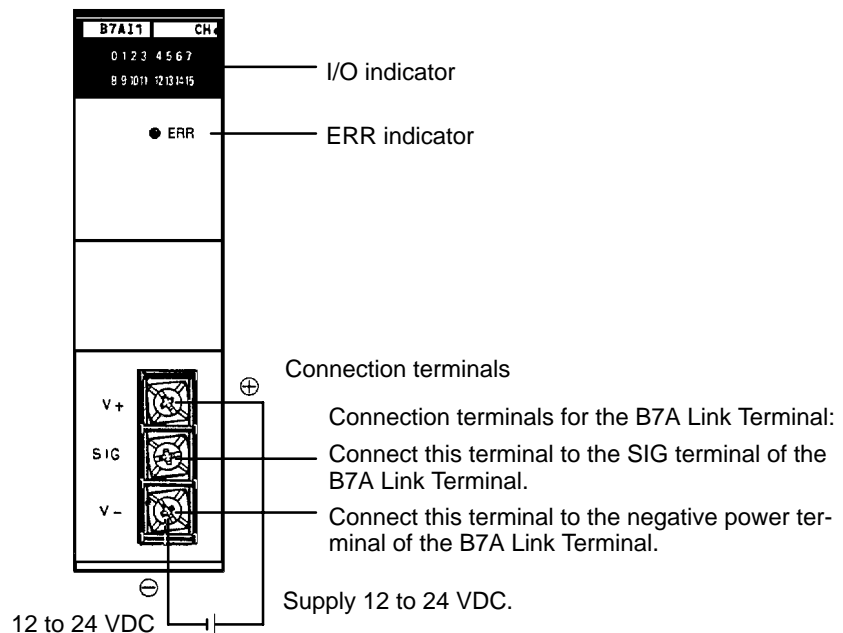

I/O Indicator

Indicates the ON or OFF status of input from the B7A Link Terminal or the ON and OFF status of output to the B7A Link Terminal.

ERR Indicator

Incorporated by the B7A11 and lit when the B7A11's data transmission or reception is abnormal.

Connection Terminals

SIG: Connects to the SIG terminal of the B7A Link Terminal.

V-: Connects to the negative power terminal of the B7A Link Terminal.

! Caution If the terminals are not connected correctly, the internal circuitry of the B7A Link Terminal will be damaged.

- Note**
1. The transmission cable must be a VCTF cable with a thickness of 0.75 mm² minimum.
 2. Do not wire power lines or high-tension lines along with the transmission cable in the same conduit.

Input Mode Selector

The B7A11 incorporates an input mode selector on the back panel of the Unit, with which the following modes can be set.

Input mode		15 points + 1 error	16 points
Function		Fifteen-point input from the B7A Link Terminal is effective. Bit 15 is used as transmission error bit.	Sixteen-point input from the B7A Link Terminal is effective.
Switch setting		Upper side	Lower side
Bit no. allocation	00 to 14	Input 00 to input 14	Input 00 to input 14
	15	Transmission error bit	Input 15
Status of input indicator lamp 15		Not used	Lit when input 15 is ON. Not lit when input 15 is OFF.
Status of the ERR indicator		Lit when there is a transmission error and OFF during normal transmission	

The ERR indicator is lit when an error occurs. If the error is corrected, the ERR indicator is OFF at the next transmission cycle.

When there is a transmission error, the B7A Link Terminal will hold the data just before the occurrence of the transmission error. If there is a transmission error because the B7A Link Terminal is turned off, however, data 0 is transmitted in the first transmission cycle when the B7A Link Terminal is turned on again.

Transmission errors between the C200H-B7AO1 and B7A Link Terminal are detected by the B7A Link Terminal only. Check the ERR indicator and error bit for any error.

Performance Specifications

Item	C200H-B7A11	C200H-B7AO1
I/O points	16 points or 15 points and 1 error input	16 output points
Transmission distance	500 m max. if power is supplied to the Interface Unit and B7A Link Terminal separately. 100 m max. if power is supplied to the Interface Unit and B7A Link Terminal from a single power supply. (24 VDC±10%)	
Transmission delay	Typ. 19.2 ms, 31 ms max.	
Minimum input time (see note 1)	---	16 ms
Internal current consumption	5 VDC, 100 mA max.	
External power supply (see note 2)	12 to 24 VDC ±10%, 10 mA min.	12 to 24 VDC ±10%, 30 mA min.
Weight	200 g max.	

- Note**
1. The minimum input time refers to the minimum time required for reading the input signals from the CPU. The ON/OFF width of the signal transmitted from the CPU to the output relay of the B7A Interface Unit should be set to a value larger than the minimum input time.
 2. The value of the external power supply does not include the value required by the B7A Link Terminal.

Group-2 B7A Interface Units (C200H-B7A□□)

A Group-2 B7A Interface Unit used with two or four B7A Link Terminals allows the transmission and reception of 32-point or 64-point I/O data over two-conductor cables.

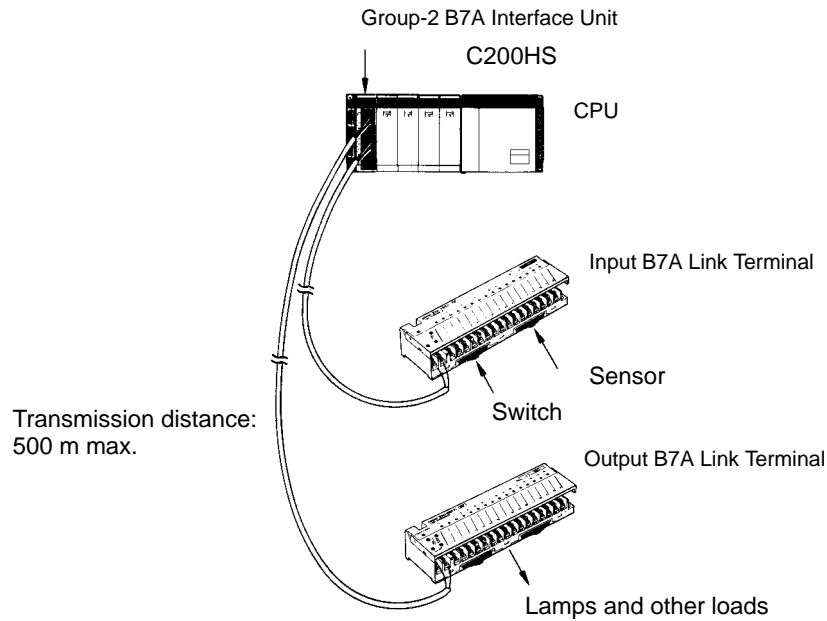

Group-2 B7A Interface Units can be mounted to a CPU Rack or an Expansion I/O Rack. They cannot be mounted to Slave Racks or to Racks controlled by any other CPUs.

The words allocated to Group-2 B7A Interface Units are determined by I/O number set on the Units. Units with 32 I/O points are allocated two words; Units with 64 I/O points are allocated four words.

Refer to the *B7A Link Terminals Datasheet* for more information on B7A Link Terminals.

Models

The following Group-2 B7A Interface Units are available.

B7A Interface Unit	Inputs	Outputs
C200H-B7A12	32 points	None
C200H-B7A02	None	32 points
C200H-B7A21	16 points	16 points
C200H-B7A22	32 points	32points

Connectable B7A Link Terminals

Only 16-point B7A Link Terminals can be connected to a B7A Interface Unit.

Input Terminals

Type	Model	Transmission delay
Screw terminals	B7A-T6□1	Standard (19.2 ms)
	B7AS-T6□1	
	B7A-T6□6	High-speed (3 ms)
	B7AS-T6□6	
Modular	B7A-T6D2	Standard (19.2 ms)
	B7A-T6D7	High-speed (3 ms)
PC connectors	B7A-T□E3	Standard (19.2 ms)
	B7A-T□E8	High-speed (3 ms)

Output Terminals

Type	Model	Transmission delay
Screw terminals	B7A-R6□□1	Standard (19.2 ms)
	B7AS-R6□□1	
	B7A-R6□□6	High-speed (3 ms)
	B7AS-R6□□6	
Modular	B7A-R6A52	Standard (19.2 ms)
	B7A-R6A57	High-speed (3 ms)
PC connectors	B7A-R□A□3	Standard (19.2 ms)
	B7A-R□A□8	High-speed (3 ms)

- Note**
- Do not connect Terminals with different transmission delays to the same Interface Unit. Doing so will cause a transmission error.
 - The 10-point B7A Link Terminals and mixed-I/O B7A Link Terminals with 8 inputs and 8 outputs cannot be connected to B7A Interface Units. Use 16-point B7A Link Terminals. The 16-point B7A Link Terminals include 16-point (non-mixed) Terminals, 32-point Terminals configured with two 16-point circuits, and mixed-I/O Terminals with 16 inputs and 16 outputs.

Comparison between Standard and Group-2 B7A Interface Units

Type	Models	Word allocations	Connectable B7A Link Terminals		
			Transmission delay	Transmission errors	Points
Standard	C200H-B7A11	Same as I/O Units (in order mounted).	Standard types only (19.2 ms)	Input status held automatically	16-point Terminals only (see note 2)
	C200H-B7A02				
Group-2	C200H-B7A12	Words 030 to 049 allocated according to I/O number setting (same as Group-2 High-density I/O Units)	Standard (19.2 ms) and high-speed (3 ms) types (set via switch)	Switch setting to hold or reset Input status.	
	C200H-B7A02				
	C200H-B7A21				
	C200H-B7A22				

- Note**
- Mount the C200H-B7A01 B7A Interface Unit to the C200H-BC□□1-V1 or C200H-BC□□1-V2 Backplane.
 - The 10-point B7A Link Terminals and mixed-I/O B7A Link Terminals with 8 inputs and 8 outputs cannot be connected to B7A Interface Units. The 16-point (non-mixed) Terminals, 32-point Terminals configured with the two 16-point circuits, and mixed-I/O Terminals with 16 inputs and 16 outputs can be connected.

Parts and Names (C200H-B7A22 shown below)

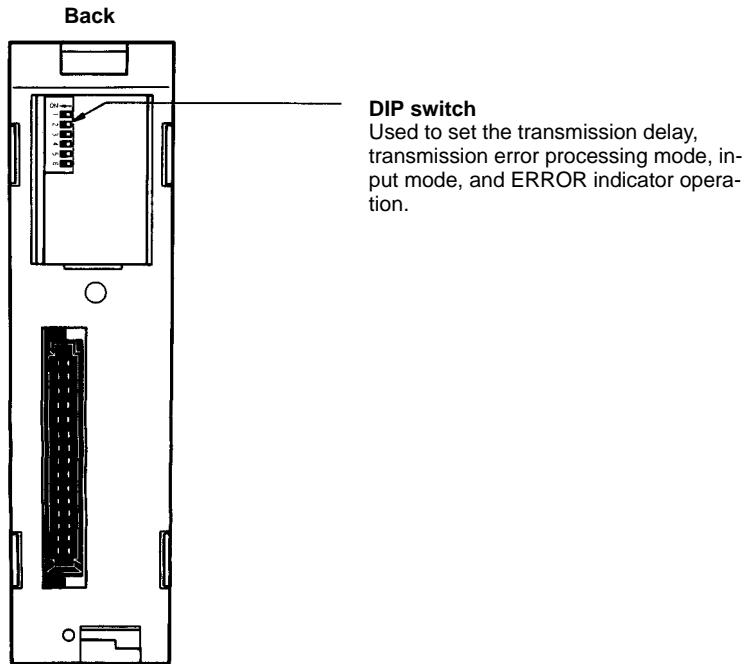
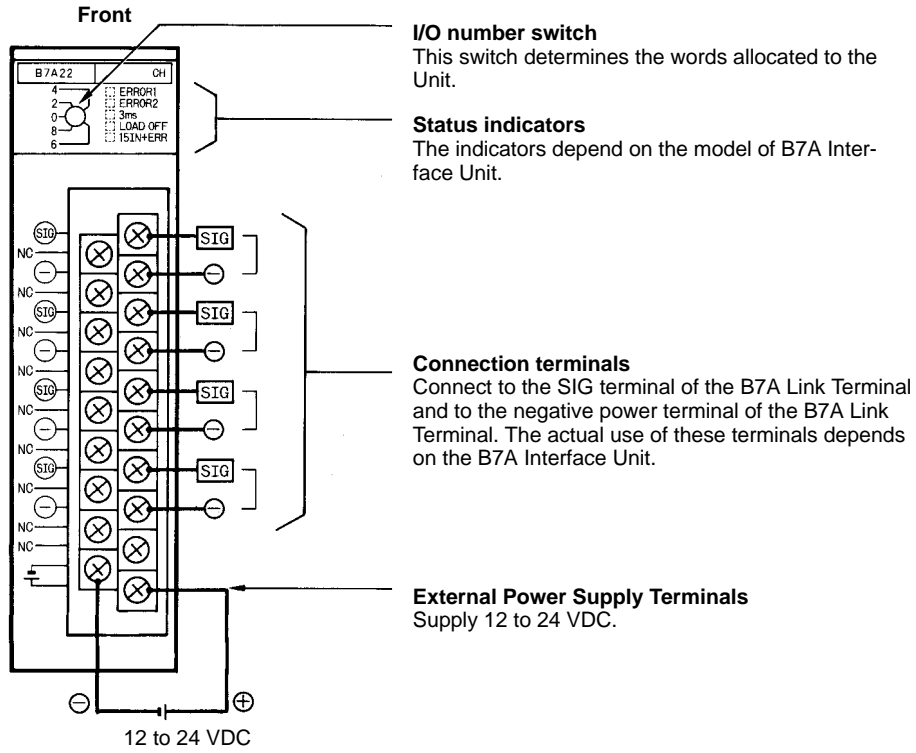

Indicator Operation

The indicators depend on the model of B7A Interface Unit, as shown below.

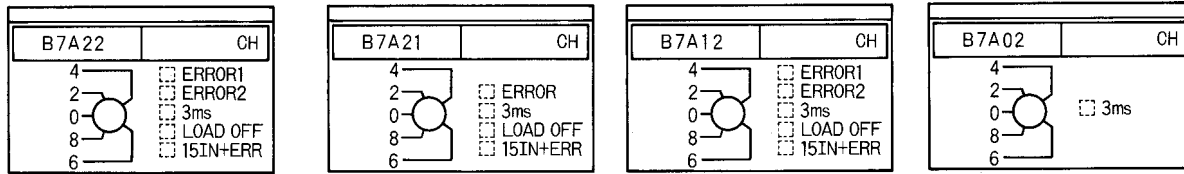

Name	Color	Function
ERROR 1 ERROR 2 ERROR	Red	Lights when an error occurs in transmissions from an Input B7A Link Terminal. For the B7A12/22, ERROR 1 is for the first word allocated to the B7A Interface Unit; ERROR 2 is for the second word.
3ms	Orange	Lit when the transmission delay is set to the high-speed setting (3 ms). Not lit when the transmission delay is set to the standard setting (19.2 ms).
LOAD OFF	Orange	Lit when the processing for transmission errors is set to reset input status. Not lit when the processing for transmission errors is set to hold input status.
15IN+ERR	Orange	Lit when the input mode mode is set to use 15 inputs and 1 error input. Not lit when the input mode mode is set to use 16 inputs.

I/O Number Setting

The setting of the I/O number determines the words allocated to the Interface Unit. Set the I/O number to between 0 and 9.

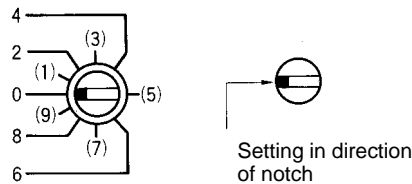

- Note**
1. Turn off the power supply to the PC before changing the I/O number setting. Any new setting will not be effective until the next time the power supply is turned on.
 2. Use a flat-blade screw driver to change the I/O number setting. Be careful not to leave the switch halfway between settings and be careful not to damage the switch.

The following table shows the words allocated according to the I/O number. The 32-point Units are the C200H-B7A12, C200H-B7A02, and C200H-B7A21. The 64-point Unit is the C200H-B7A22.

I/O No.	Words	
	32-point Units	64-point Unit
0	IR 030 and IR 031	IR 030 to IR 033
1	IR 032 and IR 033	IR 032 to IR 035
2	IR 034 and IR 035	IR 034 to IR 037
3	IR 036 and IR 037	IR 036 to IR 039
4	IR 038 and IR 039	IR 038 to IR 041
5	IR 040 and IR 041	IR 040 to IR 043
6	IR 042 and IR 043	IR 042 to IR 045
7	IR 044 and IR 045	IR 044 to IR 047
8	IR 046 and IR 047	IR 046 to IR 049
9	IR 048 and IR 049	Do not use.

- Note**
1. Be sure that the same words are not allocated to more than one Unit. For example, if you set a 64-point Unit to I/O number 0, you cannot use I/O number 1 for any Unit.
 2. The above words are also allocated to Group-2 High-density I/O Units. Be sure that the same words are not allocated to more than one Unit.

DIP Switch Settings

Set the DIP switch as described before for the various models of B7A Interface Units.

C200H-B7A22/12

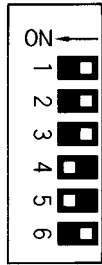

Factory setting
(pins 4 and 5 ON)

Pin	Function	OFF	ON
1	Transmission delay	Standard (19.2 ms)	High-speed (3 ms)
2	Transmission error process	Hold status	Reset Inputs
3	Input mode	16 inputs	15 inputs + error input
4	ERROR 1 indicator enable	Disabled	Enabled
5	ERROR 2 indicator enable	Disabled	Enabled
6	Not used.	NA	NA

C200H-B7A21

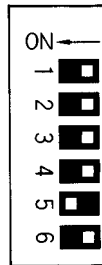

Factory setting
(pin 5 ON)

Pin	Function	OFF	ON
1	Transmission delay	Standard (19.2 ms)	High-speed (3 ms)
2	Transmission error process	Hold status	Reset Inputs
3	Input mode	16 inputs	15 inputs + error input
4	ERROR indicator enable	Disabled	Enabled
5	Not used.	NA	NA
6	Not used.	NA	NA

C200H-B7A02

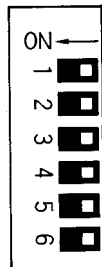

Factory setting
(all pins OFF)

Pin	Function	OFF	ON
1	Transmission delay	Standard (19.2 ms)	High-speed (3 ms)
2	Not used.	NA	NA
3	Not used.	NA	NA
4	Not used.	NA	NA
5	Not used.	NA	NA
6	Not used.	NA	NA

Transmission Delay

Pin 1 is used to set the transmission delay. The same delay is used for all words allocated to the Unit.

Set the transmission delay to match that of the B7A Link Terminal. A transmission error will occur if the same transmission delay is not set.

The “3ms” indicator will be lit whenever the high-speed (3 ms) transmission delay is set.

Transmission Error Process

Pin 2 is used to be turned ON to specify resetting input status when transmission errors occur. If pin 2 is turned OFF, input status will be held when transmission errors occur.

The LOAD OFF indicator will be lit whenever pin 2 is turned ON.

Input Mode

Pin 3 is turned ON to specify use of only 15 inputs and the use of bit 15 as a Transmission Error Flag. If pin 3 is OFF, 16 normal inputs can be used.

The “15IN+ERR” indicator will be lit whenever pin 3 is turned ON.

ERROR Indicators

Pin 4 or pins 4 and 5 are turned ON to enable the ERROR, ERROR 1, and/or ERROR 2 indicators. These indicators will not light even if a transmission error occurs if the corresponding pin is turned OFF.

Transmission Error Precautions

Startup

The Transmission Error Flag for the B7A Interface Unit will be OFF when power is turned on to the C200HS. If normal transmissions with the B7A Link Terminal are not possible within about 10 ms, the Transmission Error Flag (bit 15) will turn ON (i.e., if its operation is enabled by the input mode setting).

All input bits will remain OFF until normal transmissions are achieved.

Inputs

When a transmission error occurs, input status will be either held or all inputs will be reset according to the setting for the transmission error process, and the Transmission Error Flag (bit 15) will turn ON (i.e., if its operation is enabled by the input mode setting). The Transmission Error Flag will go OFF and the input status will return to normal when normal transmissions are achieved again.

Outputs

Transmission errors for Output B7A Link Terminals are not detected at the B7A Interface Unit and must be confirmed using the error indicators or error outputs on the Link Terminal.

Wiring

Terminal Names and Allocations

The use of the terminals depends on the model of the B7A Interface Unit. "m" indicates the first word allocated to the Unit according to the I/O number setting and can be calculated as follows:

$$m = 030 + (2 \times \text{I/O number})$$

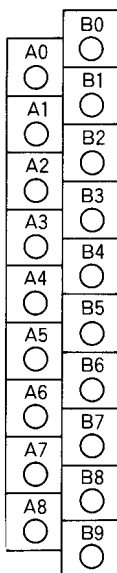

C200H-B7A22

Terminal	Name	Function	Word
B0	SIG OUT1	Connect to SIG terminal on Output B7A Link Terminal.	m
B1	- OUT1	Connect to - power supply terminal on Output B7A Link Terminal.	
B2	SIG OUT2	Connect to SIG terminal on Output B7A Link Terminal.	m + 1
B3	- OUT2	Connect to - power supply terminal on Output B7A Link Terminal.	
B4	SIG IN1	Connect to SIG terminal on Input B7A Link Terminal.	m + 2
B5	- IN1	Connect to - power supply terminal on Input B7A Link Terminal.	
B6	SIG IN2	Connect to SIG terminal on Input B7A Link Terminal.	m + 3
B7	- IN2	Connect to - power supply terminal on Input B7A Link Terminal.	
B8	NC	Not used.	NA
A0 to A7			
B9	+V	Connect to + terminal on external power supply.	
A8	-V	Connect to - terminal on external power supply.	

C200H-B7A21

Terminal	Name	Function	Word
B0	SIG OUT1	Connect to SIG terminal on Output B7A Link Terminal.	m
B1	- OUT1	Connect to - power supply terminal on Output B7A Link Terminal.	
B2, B3	NC	Not used.	NA
B4	SIG IN1	Connect to SIG terminal on Input B7A Link Terminal.	m + 1
B5	- IN1	Connect to - power supply terminal on Input B7A Link Terminal.	
B6 to B8	NC	Not used.	NA
A0 to A7			
B9	+V	Connect to + terminal on external power supply.	
A8	-V	Connect to - terminal on external power supply.	

C200H-B7A12

Terminal	Name	Function	Word
B0	SIG IN1	Connect to SIG terminal on Input B7A Link Terminal.	m
B1	- IN1	Connect to - power supply terminal on Input B7A Link Terminal.	
B2, B3	NC	Not used.	NA
B4	SIG IN2	Connect to SIG terminal on Input B7A Link Terminal.	m + 1
B5	- IN2	Connect to - power supply terminal on Input B7A Link Terminal.	
B6 to B8	NC	Not used.	NA
A0 to A7			
B9	+V	Connect to + terminal on external power supply.	
A8	-V	Connect to - terminal on external power supply.	

C200H-B7A02

Terminal	Name	Function	Word
B0	SIG OUT1	Connect to SIG terminal on Output B7A Link Terminal.	m
B1	- OUT1	Connect to - power supply terminal on Output B7A Link Terminal.	
B2, B3	NC	Not used.	NA
B4	SIG OUT2	Connect to SIG terminal on Output B7A Link Terminal.	m + 1
B5	- OUT2	Connect to - power supply terminal on Output B7A Link Terminal.	
B6 to B8	NC	Not used.	NA
A0 to A7			
B9	+V	Connect to + terminal on external power supply.	
A8	-V	Connect to - terminal on external power supply.	

Recommended Cables and Transmission Distance

The following cables are recommended to connect the B7A Interface Unit to B7A Link Terminals. The wiring method and transmission distance depend on the transmission delay and on whether or not a common power supply is being used for the B7A Link Terminal and the Interface Unit.

Standard Transmission Delays (19.2 ms): Cab-tire Cable

Power supply	Cable	Transmission distance
Common	VCTF, 0.75 mm ² x 3 conductors	100 m max.
Separate	VCTF ,0.75 mm ² x 2 conductors	500 m max.

High-speed Transmission Delays (3 ms): Shielded Cable

Power supply	Cable	Transmission distance
Common	Shielded cable, 0.75 mm ² x 3 conductors	50 m max.
Separate	Shielded cable, 0.75 mm ² x 2 conductors	100 m max.

Terminal Construction

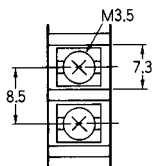

Use hook-type crimp connectors with a line thickness of 0.25 to 1.65 mm². The construction of the terminals is shown in the illustration.

Wiring Method

Standard Transmission Delays (19.2 ms)

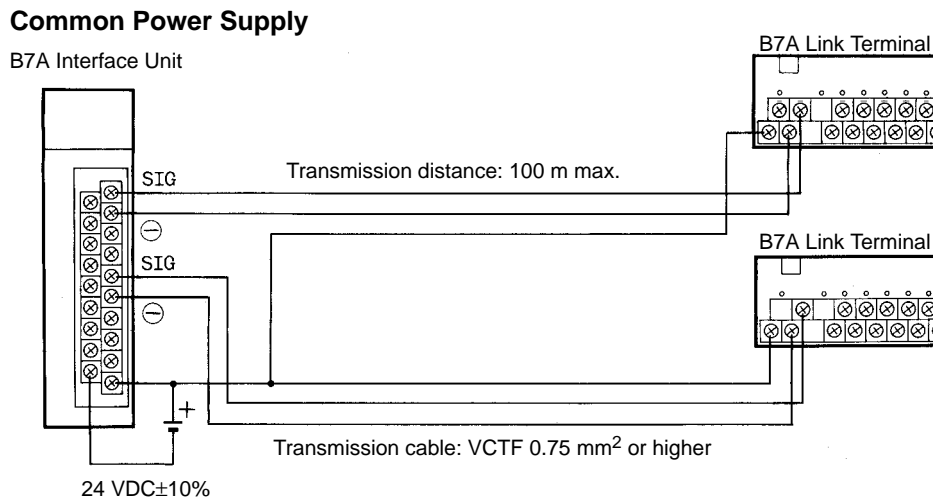

Separate Power Supplies

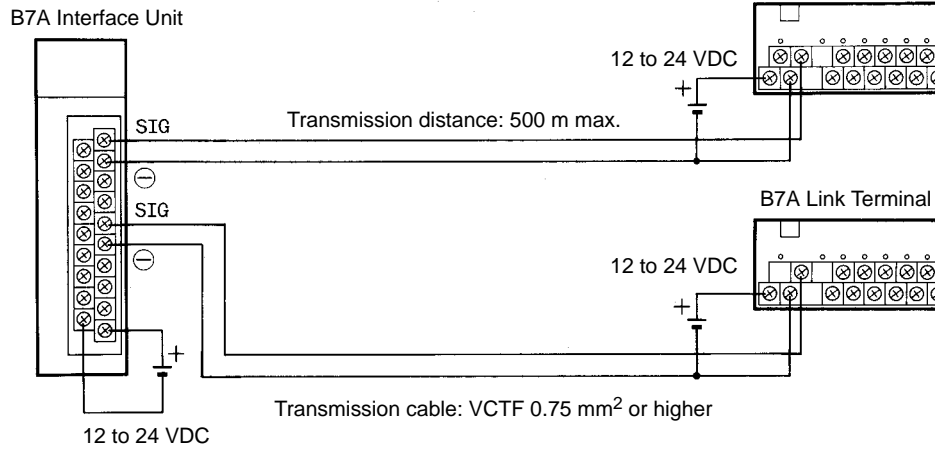

High-speed Transmission Delays (3 ms): Shielded Cable

Common Power Supply

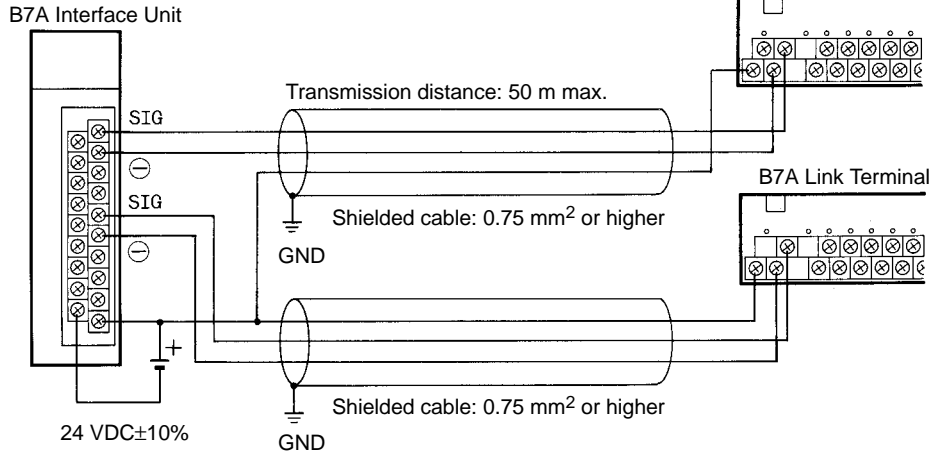

Separate Power Supplies

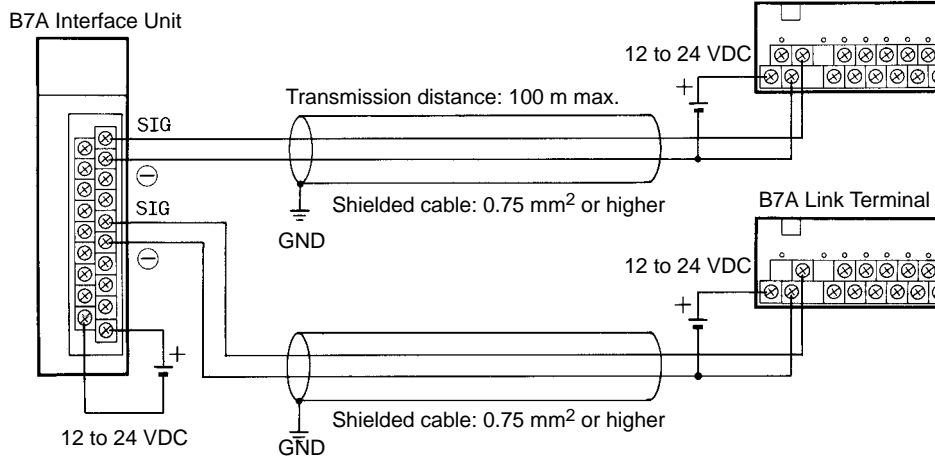

- Note**
1. We recommend grounding the shielded cable.
 2. If shielded cable is not used, the maximum transmission distance is 10 m regardless of whether a common or separate power supplies are used. Use 0.75 mm² or higher VCTF cable.
 3. To prevent noise on the transmission cable, do not lay it near power cables or high-voltage lines.

Specifications

Item	C200H-B7A12	C200H-B7A02	C200H-B7A21	C200H-B7A22
I/O points	32 input points or 30 input points and 2 error inputs	32 output points	16 output points and 16 input points or 15 input points + 1 error input	32 output points and 32 input points or 30 input points + 2 error inputs
Transmission method	One-way distributed multiplex transmission			
Transmission distance (see note 1)	Standard: 500 m max. High-speed: 100 m max.			
Transmission delay	Standard: Typ. 19.2 ms, 31 ms max. High-speed: Typ. 3 ms, 5 ms max.			
Minimum input time (see note 2)	Standard: 16 ms High-speed: 2.4 ms			
Internal current consumption	5 VDC, 100 mA max.			
External power supply (see note 3)	12 to 24 VDC \pm 10%			
	0.05 A min.	0.06 A min.	0.05 A min.	0.08 A min.
Weight	300 g max.			
Dimensions	35 x 130 x 128 mm (W x H x D)			

- Note**
1. The transmission distance also depends on whether a common or separate power supplies are used.
 2. The minimum input time refers to the minimum time required for reading the input signals from the CPU. The ON/OFF width of the signal transmitted from the CPU to the output relay of the B7A Interface Unit should be set to a value larger than the minimum input time.
 3. The capacity of the external power supply does not include the capacity required by the B7A Link Terminal.

Maximum Current and Power Supplied

There are limits to the current and power that can be supplied to each Rack and Unit. When designing the system, take the current consumption into account.

Follow the chart below and be careful that the total current consumption does not exceed the maximum current and maximum total power supplied.

Current Supplied

Name	Model number	Max. current supplied			Maximum power supplied
		5 V (internal logic current)	26 V (relay drive current)	24 V (No-voltage contact current)	
CPU Rack	C200HS-CPU01-E/ CPU01-EC/CPU21-E/ CPU21-EC/CPU31-E	3.9 A	0.6 A	0.8 A	23.5 to 26.5 W (See conditions below.)
	C200HS-CPU03-E/ CPU23-E/CPU33-E	2.3 A	0.6 A	---	21.5 W
Expansion I/O Rack	C200H-PS221/ PS221-C	2.7 A	0.6 A	0.8 A	28 W
	C200H-PS211			---	23 W
Slave Rack	C200H-RT001-P	2.7 A	0.6 A	0.8 A	28 W
	C200H-RT002-P			---	23 W
	C200H-RT201			0.8 A	28 W
	C200H-RT202			---	23 W

Note The figures shown in the “maximum current supplied” and “maximum power supplied” columns are computed with the power consumed by the Backplanes, CPU, Memory Cassettes, Peripheral Devices, I/O Power Supply Units, and Slave Units already calculated.

Design the system so that the following conditions are satisfied.

Condition 1

- (1) (Total current consumption of all Units in the 5-V system) ≤ (the figure in the 5-V column)
- (2) (Total current consumption of all Units in the 26-V system) ≤ (the figure in the 26-V column)
- (3) (Total current consumption of all Units in the 24-V system) ≤ (the figure in the 24-V column)

Condition 2

(1) x 5 V + (2) x 26 V + (3) x 24 ≤ (maximum power supplied)
 In the C200HS-CPU01-E/CPU01-EC/CPU21-E/CPU21-EC/CPU31-E, the maximum power drawn from the 5-V power supply depends upon the current consumption, as shown below.

Max. Power vs. Current Supplied

C200HS-CPU01-E/CPU01-EC/CPU21-E/CPU21-EC/CPU31-E

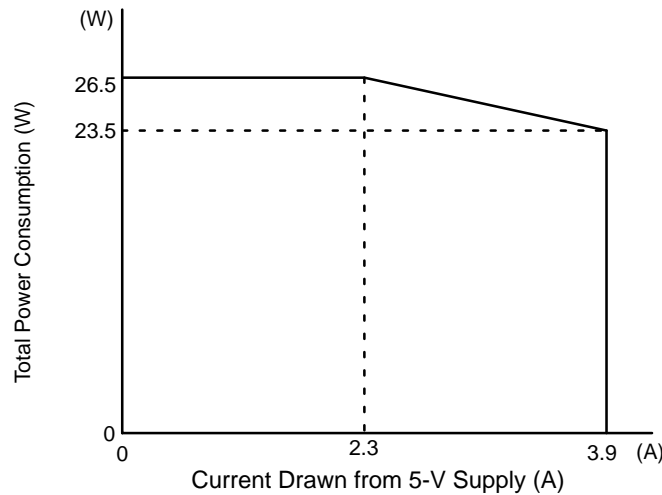

Calculating Current and Power Consumption

The method of calculating current and power consumption is demonstrated here using the following Unit combinations as examples.

Example 1: Units Mounted to C200HS-CPU01-E CPU Rack

- OC221 Contact Output Units: 4 Units
- ID001 No-voltage Input Units: 3 Units
- LK202 Host Link Unit: 1 Unit
- External power supply used: 0.3 A

<u>Power Supply</u>	<u>Current Consumption</u>	<u>Power Consumption</u>
5-V system	$0.001 \times 7 + 0.25 = 0.32 \text{ A} (\leq 3.9 \text{ A})$	$0.32 \text{ A} \times 5 \text{ V} = 1.6 \text{ W}$
26-V system	$0.075 \times 4 = 0.30 \text{ A} (\leq 0.6 \text{ A})$	$0.30 \text{ A} \times 26 \text{ V} = 7.8 \text{ W}$
24-V system	$0.06 \times 3 + 0.3 = 0.48 \text{ A} (\leq 0.8 \text{ A})$	$0.48 \text{ A} \times 24 \text{ V} = 11.52 \text{ W}$
Total = 20.92 W ($\leq 26.5 \text{ W}$)		

Example 2: Units Mounted to C200H-PS221 Expansion I/O Rack

- ID212 DC Input Units: 6 Units
- CT002 High-speed Counter Units: 2 Units
- External power supply used (for ID212): 0.8 A

<u>Power Supply</u>	<u>Current Consumption</u>	<u>Power Consumption</u>
5-V system	$0.01 \times 6 + 0.3 \times 2 = 0.66 \text{ A} (\leq 2.7 \text{ A})$	$0.66 \text{ A} \times 5 \text{ V} = 3.3 \text{ W}$
26-V system	0	0
24-V system	Ext. power supply = 0.8 A ($\leq 0.8 \text{ A}$)	$0.8 \text{ A} \times 24 \text{ V} = 19.2 \text{ W}$

Total = 22.5 W (≤ 28 W)

Example 3: Units Mounted to C200HS-CPU01-E CPU Rack

OC221 Contact Output Units: 4 Units
 ID217 High-density Input Unit: 1 Unit
 OD219 High-density Output Unit: 1 Unit
 CT002 High-speed Counter Unit: 1 Unit
 External power supply used (for ID217): 0.3 A

Power Supply	Current Consumption	Power Consumption
5-V system	0.01 x 4 + 0.12 + 0.27 + 0.3 = 0.73 A (≤ 3.9 A)	0.73 A x 5 V = 3.65 W
26-V system	0.075 x 4 = 0.30 A (≤ 0.6 A)	0.3 A x 26 V = 7.8 W
24-V system	Ext. power supply = 0.8 A (≤ 0.8 A)	0.8 A x 24 V = 19.2 W
Total = 18.65 W (≤ 26.5 W)		

Calculating Power Consumption for Racks

The total power consumption (primary power input) for an individual Rack can be broadly calculated as shown in the following examples.

Example 1: CPU Rack

$$\frac{\text{Total power consumption of Units} + 3.5}{0.6 \times 0.55 (1) (VA)}$$

3.5 = CPU power consumption
 0.6 = 60% efficiency
 0.55 (1) = Power rate (Number in parentheses: when CPU03 is used.)

Example 2: All Other Racks

$$\frac{\text{Total power consumption of Units} + 2}{0.6 \times 0.55 (1) (VA)}$$

2 = I/O Power Supply Unit (Remote I/O Slave Unit) power consumption
 0.6 = 60% efficiency
 0.55 (1) = Power rate (Number in parentheses: when PS211, RT002-P or RT202 is used.)

Current Drawn from 5-V Supply (Standard I/O Units)

Unit	Model number	Current consumption
DC Input	C200H-ID211	0.01 A each
	C200H-ID212	
No-Voltage Contact Input	C200H-ID001	
	C200H-ID002	
AC Input	C200H-IA121	
	C200H-IA122/IA122V	
	C200H-IA221	
	C200H-IA222/IA222V	
AC/DC Input	C200H-IM211	
	C200H-IM212	
Contact Output	C200H-OC221	
	C200H-OC222	
	C200H-OC223	
	C200H-OC224	
	C200H-OC225	0.05 A
	C200H-OC222V	0.008 A
	C200H-OC224V	0.01 A
	C200H-OC226	0.03 A

Unit	Model number	Current consumption
Transistor Output	C200H-OD411	0.14 A
	C200H-OD211	0.16 A
	C200H-OD212	0.18 A
	C200H-OD213	0.14 A
	C200H-OD214	
	C200H-OD216	0.01 A each
	C200H-OD217	
	C200H-OD21A	0.16 A
Triac Output	C200H-OA121-E	0.14 A
	C200H-OA122-E	0.18 A
	C200H-OA221	0.14 A
	C200H-OA223	0.18 A
	C200H-OA222V	0.20 A
	C200H-OA224	0.27 A
Analog Timer	C200H-TM001	0.06 A
Standard B7A Interface	C200H-B7AI1	0.10 A
	C200H-B7AO1	
Interrupt Input	C200HS-INT01	0.02 A

Current Drawn from 5-V Supply for Group-2 High-density I/O Units

Unit	Model number	Current consumption
DC Input	C200H-ID111	0.12 A
	C200H-ID216	0.1 A
	C200H-ID217	0.12 A
	C200H-ID218	0.1 A
	C200H-ID219	0.12 A
Transistor Output	C200H-OD218	0.18 A
	C200H-OD219	0.27 A
	C200H-OD21B	0.18 A

Current Drawn from 5-V Supply for Group-2 B7A Interface Units

Unit	Model number	Current consumption
B7A Interface Unit (Group-2 Units)	C200H-B7A12/02	0.10 A
	C200H-B7A21/22	

Current Drawn from 5-V Supply for Special I/O Units

Unit	Model number	Current consumption
TTL Input	C200H-ID501	0.13 A
DC Input	C200H-ID215	
TTL Output	C200H-OD501	0.22 A
Transistor Output	C200H-OD215	
TTL I/O	C200H-MD501	0.18 A
DC Input/Transistor Output	C200H-MD115	
	C200H-MD215	
High-speed Counter	C200H-CT001-V1	0.30 A
	C200H-CT002	
Position Control	C200H-NC111	0.15 A
	C200H-NC112	
	C200H-NC211	0.50 A
Analog Input	C200H-AD001	0.55 A
	C200H-AD002	0.45 A

Unit	Model number	Current consumption
Analog Output	C200H-DA001	0.65 A
	C200H-DA002	0.60 A
Temperature Control	C200H-TC001	0.33 A
	C200H-TC002	
	C200H-TC003	
	C200H-TC101	
	C200H-TC102	
	C200H-TC103	
Heat/Cool Temperature Control	C200H-TV001	0.33 A
	C200H-TV002	
	C200H-TV003	
	C200H-TV101	
	C200H-TV102	
	C200H-TV103	
PID Control	C200H-PID01	0.33 A
	C200H-PID02	
	C200H-PID03	
Temperature Sensor Input	C200H-TS001/TS002	0.45 A
	C200H-TS101/TS102	
ASCII	C200H-ASC02	0.20 A
Voice Output	C200H-OV001	0.30 A
ID Sensor	C200H-IDS01-V1	0.25 A
	C200H-IDS21	
Fuzzy Logic	C200H-FZ001	0.30 A
Cam Positioner	C200H-CP114	0.30 A

Current Drawn from 5-V Supply for Other Units

Unit	Model number	Current consumption
Host Link	C200H-LK101-PV1	0.25 A
	C200H-LK201-V1	0.15 A
	C200H-LK202-V1	0.25 A
PC Link	C200H-LK401	0.35 A
Remote Master	C200H-RM001-PV1	0.20 A
	C200H-RM201	0.25 A
SYSMAC LINK	C200HW-SLK13/SLK14/SLK23/SLK24	0.80 A
SYSMAC NET Link	C200HS-SNT32	1.00 A
Power Supply Adapter	C200H-APS01/APS02/APS03	0 A
CompoBus/S Master	C200HW-SRM21	0.15 A
DeviceNet Master	C200HW-DRM21	0.25 A

Current Drawn from 26-V Supply

Unit	Model number	Current consumption
Contact Output	C200H-OC221/OC222/OC223/OC224/OC225	0.075 A/8 points that turn ON simultaneously
	C200H-OC222V/OC224V/OC226	0.09 A/8 points that turn ON simultaneously
Transistor Output	C200H-OD216/OD217	0.075 A/8 points that turn ON simultaneously
ID Sensor	C200H-IDS01-V1/IDS21	0.12 A

Current Drawn from 24-V Supply

Unit	Model number	Current consumption
No-Voltage Contact Input	C200H-ID001/ID002	0.06 A each

Dimensions

Racks

The dimensions shown below are for both the CPU Rack and Expansion I/O Rack. The C dimension for the Programming Console will increase by 30mm when the Programming Console Adapter C200H-BP001 is used, and will increase by 50 mm when the Programming Console Adapter C200H-BP002 is used.

CPU

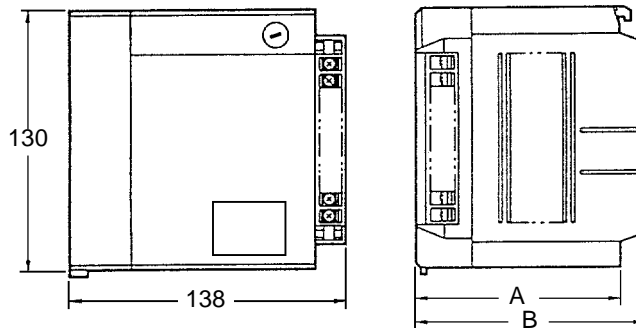

Model	A (mm)	B (mm)	Weight (kg)
C200HS-CPU01-E/CPU01-EC/CPU03-E	101	113	1.4
C200HS-CPU21-E/CPU21-EC/CPU23-E/CPU31-E/CPU33-E	126	138	1.5

Memory Cassette

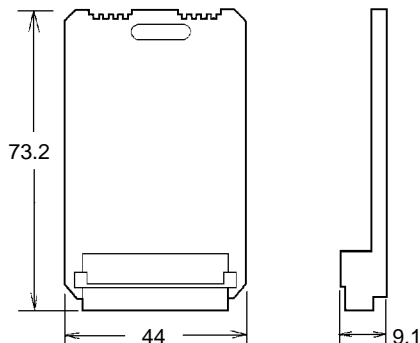

C200H-PS221/PS221-C/PS211 I/O Power Supply Unit

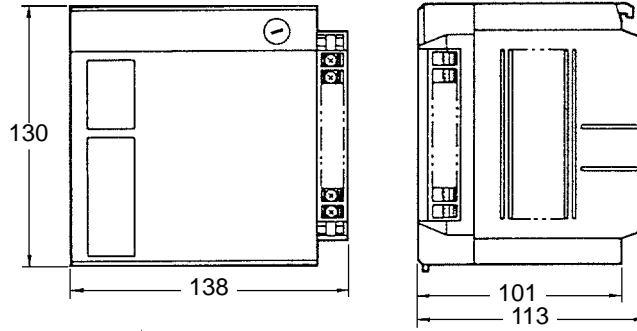

Backplane



Model	Width (W)	Weight
C200H-BC031-V2	260 mm	0.8 kg max.
C200H-BC051-V2	330 mm	1.0 kg max.
C200H-BC081-V2	435 mm	1.3 kg max.
C200H-BC101-V2	505 mm	1.5 kg max.

I/O Connecting Cables

The dimensions shown below are for I/O Connecting Cables.



Cable	Length (L)
C200H-CN311	30 cm
C200H-CN711	70 cm
C200H-CN221	2 m
C200H-CN521	5 m
C200H-CN131	10 m

C200H-PRO27 Programming Console

The dimensions shown below are for the Programming Console.

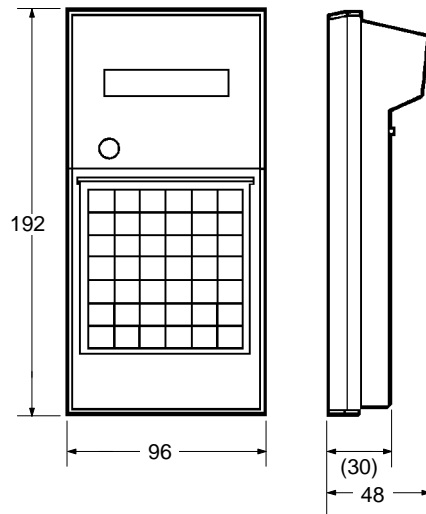

C200H-CN222/CN422, C200HS-CN222/CN422 Connecting Cable

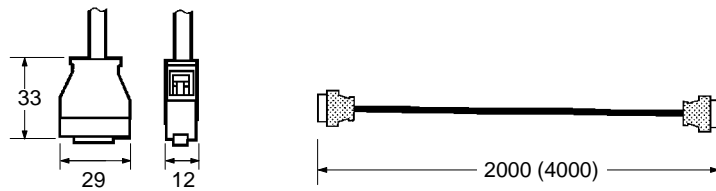

Standard I/O Units

The dimensions shown below are for the three shapes of Standard I/O Units mentioned throughout these specifications.

10-terminal Terminal Block (A-shape I/O Units)

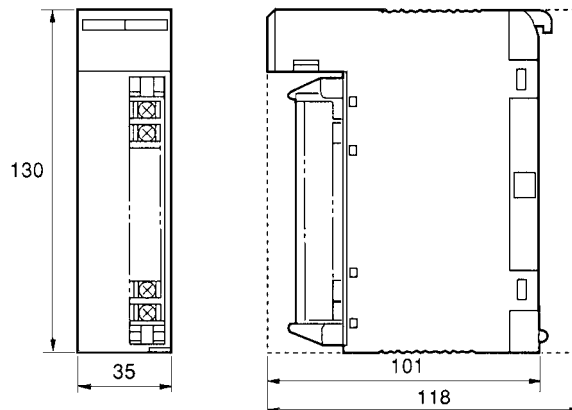

19-terminal Terminal Block (B-shape I/O Units)



10-terminal Terminal Block (E-shape I/O Units)



19-terminal Terminal Block (Extended B-shape I/O Units)



Terminal Dimensions

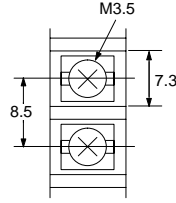

Group-2 High-density I/O Units

The dimensions shown below are for the Group-2 High-density I/O Units.

Group-2 High-density I/O Units (C and D Types)

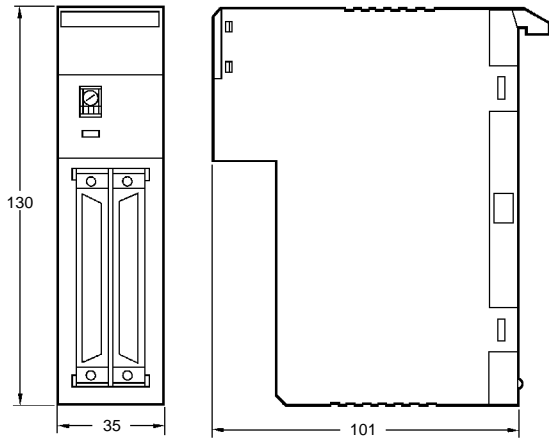

Dimensions with Unit Mounted

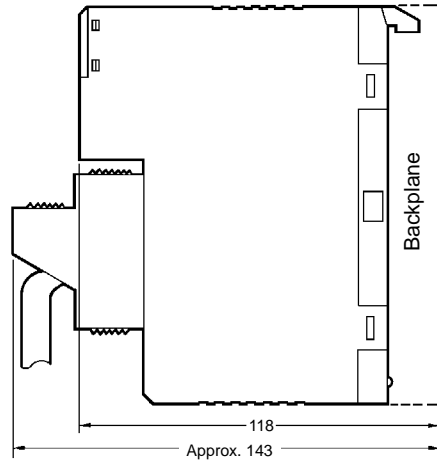

High-density I/O Units (Special I/O Units)

The dimensions shown below are for the High-density I/O Units classified as Special I/O Units.

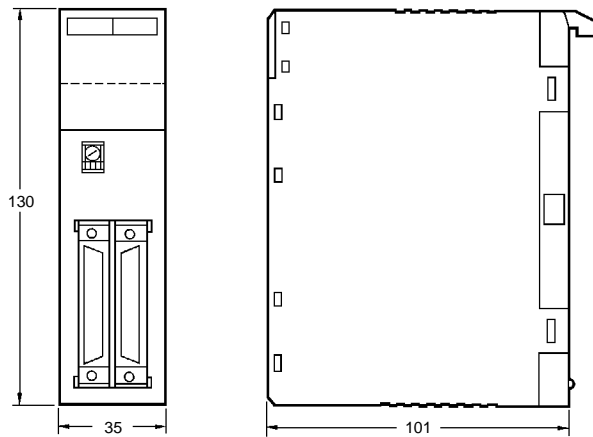

Dimensions with Unit Mounted

Fujitsu's Connector is Used

G79-□C Connecting Cable is Used

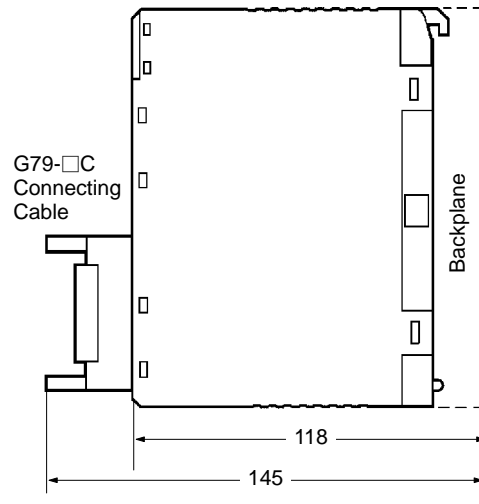
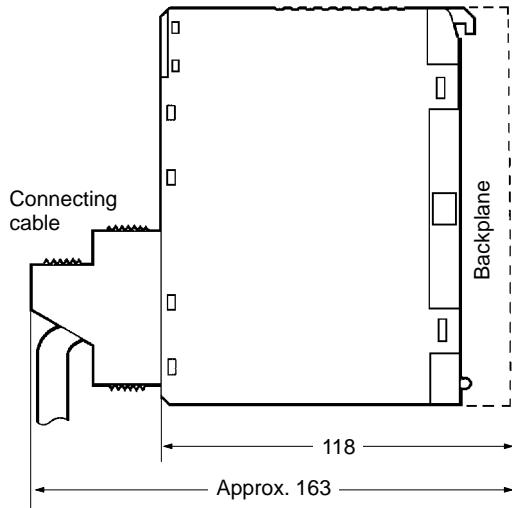

Interrupt Input Unit

The dimensions shown below are for the Interrupt Input Unit classified as Special I/O Units.

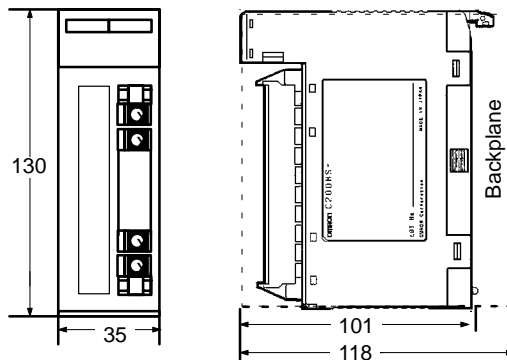

Standard B7A Interface Unit

The dimensions shown below are for the B7A Interface Unit classified as Special I/O Units.

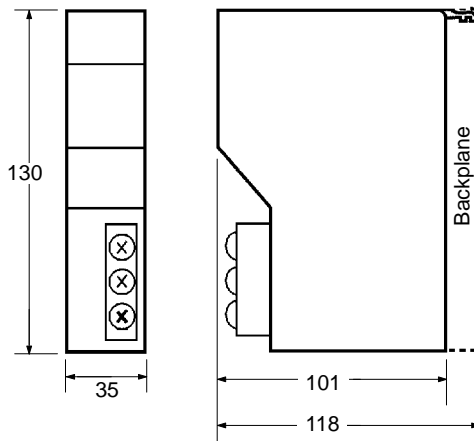

Group-2 B7A Interface Units The dimensions shown below are for the Group-2 B7A Interface Units.

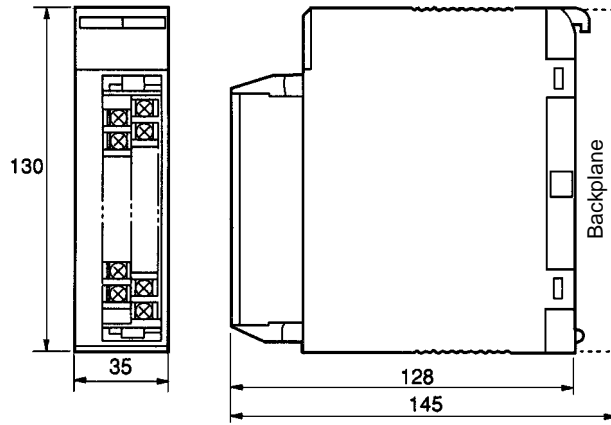

Analog Timer Unit

The dimensions shown below are for the Analog Timer Unit classified as Special I/O Units.

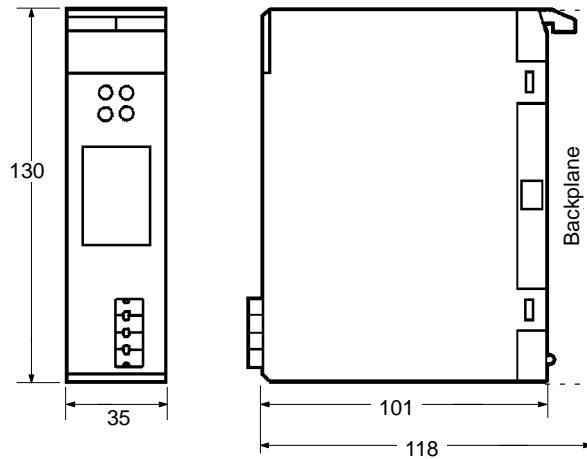

Mounting Dimensions

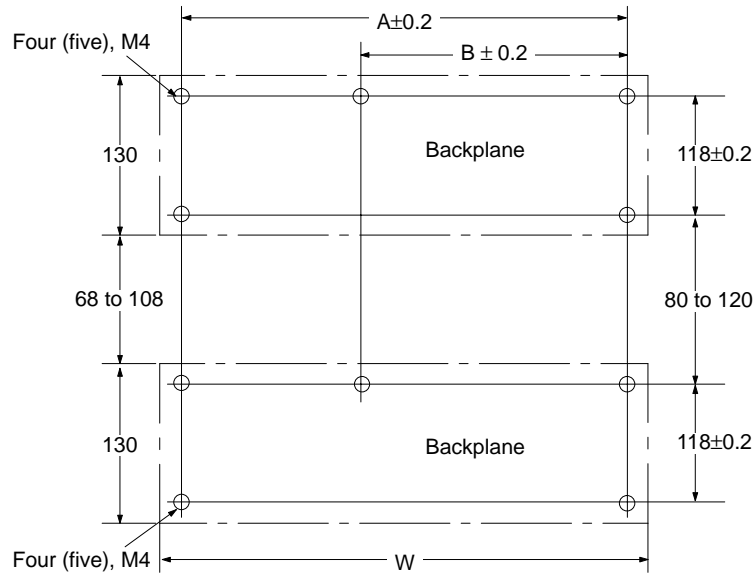

Model	A±0.2	B±0.2	W
C200H-BC031-V2	246 mm	---	260 mm
C200H-BC051-V2	316 mm	---	330 mm
C200H-BC081-V2	421 mm	---	435 mm
C200H-BC101-V2	491 mm	270.5 mm	505 mm

Panel Mounting of C200H-PRO27 Programming Console

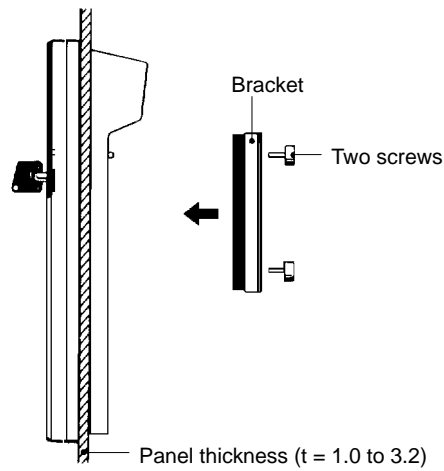

The following is the standard panel cut dimensions for the Programming Console (conforming to DIN 43700).



Use the C200H-ATT01 Mounting Bracket (sold separately) to mount the C200H-PRO27 Programming Console to panels.

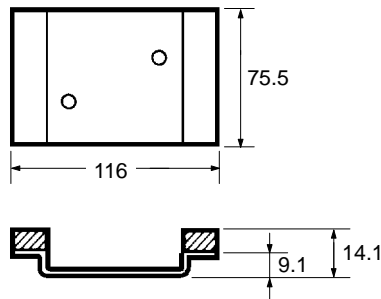

Take the space required for the cable into consideration when mounting the Programming Console to panels.

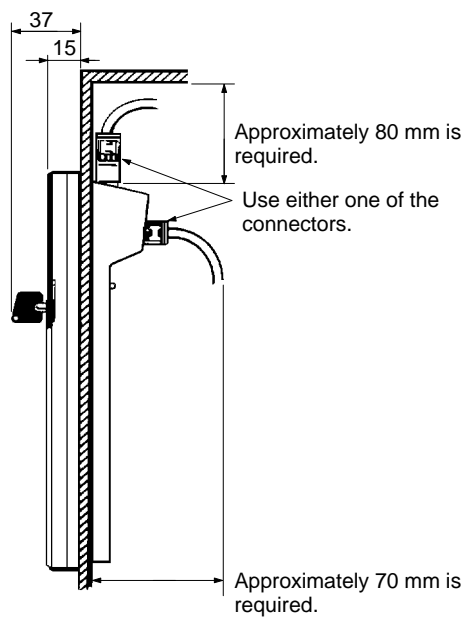

RS-232C Port Specifications

RS-232C Specifications

The specifications for the RS-232C port are given below. Devices that meet these specifications can be connected.

Connector Pin Assignments

Pin assignments for the RS-232C port are given in the following table.

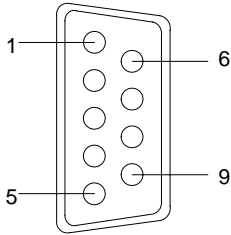

Pin	Abbreviation	Name	Direction
1	FG	Field ground	---
2	SD (TXD)	Send data	Output
3	RD (RXD)	Receive data	Input
4	RS (RTS)	Request to send	Output
5	CS (CTS)	Clear to send	Input
6	---	Not used.	---
7	---	Not used.	---
8	---	Not used.	---
9	SG	Signal ground	---
Connector fitting	FG	Field ground	---

System Configurations

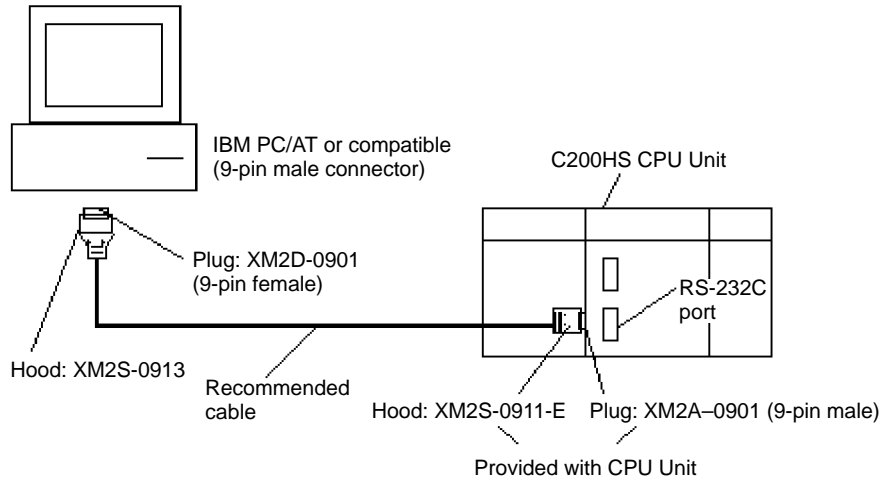

Connections

The connections between the C200HS and a personal computer are illustrated below as an example.

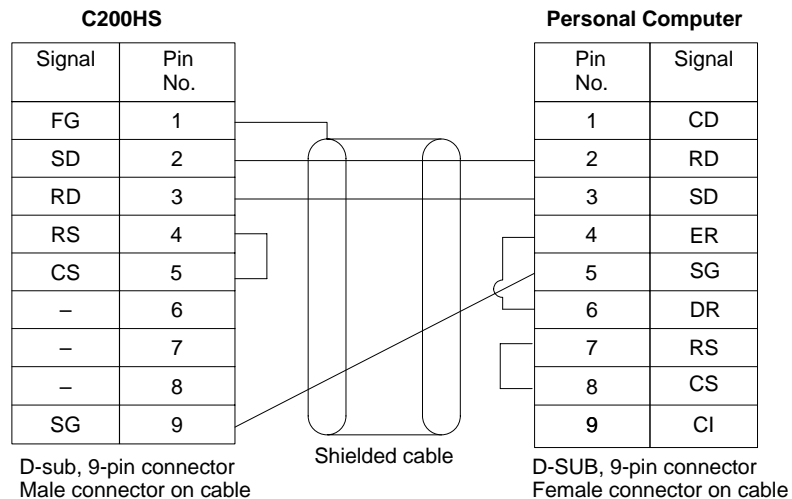

Applicable Connectors

The following connectors are applicable. One plug and one hood are included with the CPU.

CPU Unit Connector

Item	Model	Specifications	
Plug	XM2A-0901	9-pin male	Used together (One of each provided with CPU Unit.)
Hood	XM2S-0911-E	9-pin, millimeter screws, static-resistant	

Personal Computer Connector

Item	Model	Specifications	
Plug	XM2D-0901	9-pin female	Used together
Hood	XM2S-0913	9-pin, inch screws	

Port Specifications

Item	Specification
Communications method	Half duplex
Sync	Start-stop
Baud rate	1,200, 2,400, 4,800, 9,600, or 19,200 bps
Transmission method	Point to point
Transmission distance	15 m max.
Interface	EIA RS-232C

One-to-one Link Connections The RS-232C port on the C200HS can be connected to the same port on another C200HS. Wire the cable as shown in the diagram below.

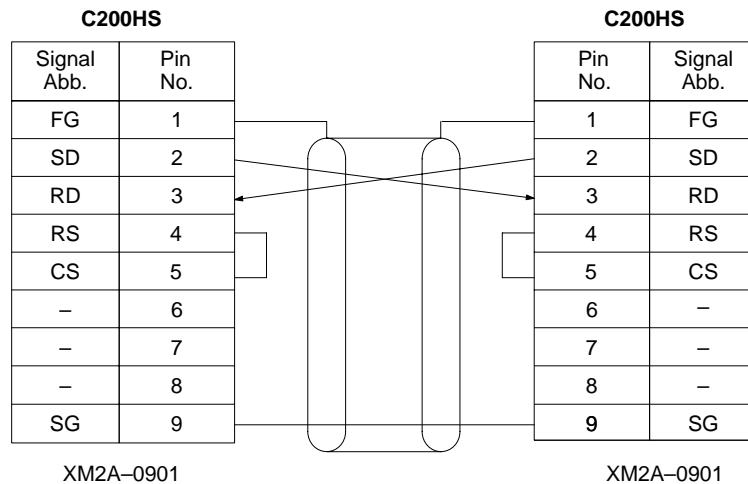

Ground the FG terminals of C200HS Units at a resistance of less than 100 Ω.

Glossary

ASCII code	[A(merican) S(tandard) C(ode for) I(nformation) I(nterchange)] A standard computer code used to facilitate the interchange of information among various types of data-processing equipment.
ASCII Unit	An Intelligent I/O Unit. The ASCII Unit has its own CPU and 16 kilobytes of memory. This Unit enables communication between the PC and any other device which uses ASCII code. The ASCII Unit can be programmed in BASIC.
Backplane	A base to which Units are mounted to form a Rack. Backplanes provide a series of connectors for these Units along with wiring to connect them to the CPU and Power Supply. Backplanes also provide connectors used to connect them to other Backplanes. In some Systems, different Backplanes are used for different Racks; in other Systems, Racks differ only by the Units mounted to them.
back-up	A copy of existing data which is valuable if data is accidentally erased.
baud rate	Transfer speed between two devices in a system measured in bits per second. For example, an optical sensor might be configured to send its information to the personal computer at 9600 baud. It is important for both of the devices to be set to the same baud rate.
bit	The smallest piece of information that can be represented on a computer. A bit has the value of either zero or one, corresponding to the electrical signals ON and OFF. A bit is one binary digit.
central processing unit	A device that is capable of storing a program and data, and executing the set of instructions contained in the program. In a PC System, the central processing unit executes the program, processes I/O signals, communicates with external devices, etc.
communication cable	Cable used to transfer data between components of a control system and conforming to the RS-232C or RS-422 standards.
Control System	All of the hardware and software components used to control other devices. A Control System includes the PC System, the PC programs, and all I/O devices that are used to control or obtain feedback from the controlled system.
counter	A PC function that counts the number of occurrences of a certain event.
CPU	An acronym for central processing unit.
cycle time	The total time it takes the PC to perform internal operations, i.e., reset the watchdog timer, read the program, receive input data, send output data, and execute instructions. Cycle time is monitored by the watchdog timer within the PC, and if it takes longer than a certain specified amount of time, an error message may be generated, or the CPU may just stop. Cycle times will differ depending on the configuration of the system.
data area	An area in the PC's memory that is designed to hold a specific type of data, e.g., the LR area is designed to hold common data in a PC Link System.
data link	Allows for the connection of up to 32 PCs in a Net Link System where each is contributing information to a common memory area. Data links may be established in the LR and/or DM memory areas.

debugging	The process of checking for errors in a program.
default condition	The original condition of a function or system. For example, the Ladder Support Software's (LSS) installation utility will place the LSS in the C:\LSS directory, but this default condition can be changed so that it places the LSS in a different directory.
distributed control	An automation concept in which control of each portion of an automated system is located near the devices actually being controlled, i.e., control is decentralized and "distributed" over the system. Distributed control is a concept basic to PC Systems.
EEPROM	[E(lectrically) E(rasable) P(rogrammable) R(ead) O(nly) M(emory)] A type of ROM in which stored data can be erased and reprogrammed. This is accomplished using a special control lead connected to the EEPROM chip and can be done without having to remove the EEPROM chip from the device in which it is mounted.
electrical noise	Electric 'static' that can disturb electronic communications. The 'snow' that can appear on a TV screen is an example of the effects of electrical noise.
EPROM	[E(rasable) P(rogrammable) R(ead) O(nly) M(emory)] A type of ROM in which stored data can be erased, by ultraviolet light or other means, and reprogrammed.
Expansion I/O Unit	An I/O Unit for a Package-type PC that provides more I/O points to the PC.
factory computer	A general-purpose computer, usually quite similar to a business computer, that is used in automated factory control.
flag	A bit that is turned ON and OFF automatically by the system in order to provide status information.
High-speed Counter	A Special I/O Unit. A High Speed Counter Unit counts independently of the PC's cycle time. This allows counting of very short, fast signals.
host computer	A computer that is used to transfer data to or receive data from a PC in a Host Link system. The host computer is used for data management and overall system control. Host computers are generally small personal or business computers.
IBM PC/AT or compatible	A computer that has similar architecture to, and is logically compatible with an IBM PC/XT computer; and that can run software designed for that computer.
instruction line	A succession of instructions which begins with a load instruction at the left bus bar and ends at a right bus bar.
interface	An interface is the conceptual boundary between systems or devices and usually involves changes in the way the communicated data is represented. Interface devices such as NSBs perform operations such as changing the coding, format, or speed of data.
I/O devices	The devices which are connected to the terminals on I/O Units, Special I/O Units, or Intelligent I/O Units. I/O devices may be part of the Control System if they function to help control other devices, or they may be part of the controlled system if they interact directly with it.
I/O point	The place at which an input signal enters the PC System or an output signal leaves the PC System. In physical terms, an I/O point corresponds to terminals

or connector pins on a Unit; in terms of programming, an I/O point corresponds to an I/O bit in the IR area.

I/O table	Diagram written to the IR memory area listing the type of I/O units controlled by a PC. It must be cleared before programming or when I/O units are changed. Tables can be read, verified, or transferred to a EPROM.
I/O Unit	The most basic type of Unit mounted to a Backplane. I/O Units include Input Units and Output Units, each of which is available in a range of specifications. I/O Units do not include Special I/O Units, Link Units, etc.
Limit Switch	A switch that detects when an object has reached the limit of its movement by actually making contact with the object. Limit Switches are fitted to electric elevators, traveling cranes, etc. to indicate when a certain part of the equipment has traveled to the specified limit.
Link Unit	Any of the Units used to connect a PC to a Link System. These are Remote I/O Units, I/O Link Units, PC Link Units, Host Link Units, and Net Link Units.
operating mode	The Display Terminal Unit can operate in five different modes: Page Read, Terminal. Dynamic Scan, Read/Write, and Self-Diagnosis.
page	One complete Display Terminal Unit screen. Two hundred screens can be stored on one RAM card.
parallel interface	The parallel interface uses the RS-232 connector, but is not serial communication. When parallel mode is selected as the communication mode, up to 16 Display Terminal Units can be connected to a PC in parallel.
PC	An acronym for Programmable Controller.
PCB	An acronym for printed circuit board.
PC Link Unit	A Unit used to connect two or more PCs together so that they can exchange data through their LR areas.
Photoelectric Switch	A switch that uses light to detect the presence of an object.
Power Supply	A Unit that mounts to a Backplane in a Rack PC. It provides power at the voltage required by the other Units on the Rack.
printed circuit board	A board onto which electrical circuits are printed for mounting into a computer or electrical device.
Programmable Controller	A small, computer-like device that can control peripheral equipment, such as an electric door or quality control devices, based on programming and peripheral input devices. Any process that can be controlled using electrical signals can be controlled by a PC. PCs can be used independently or networked together into a system to control more complex operations.
programming device	A peripheral device used to write programs and to input a program to a PC or to alter or monitor a program already stored in the PC. There are dedicated programming devices, such as Programming Consoles, and there are non-dedicated programming devices, such as a host computer.
PROM	[P(rogrammable) R(ead) O(nly) M(emory)] A type of ROM into which the program or data may be written after manufacture, by a customer, but which is fixed from that time on.

PROM Writer	A PROM Writer is a device used to write data to ROM, PROM, and EPROM storage chips.
Proximity Switch	A switch that uses magnetic induction to measure the distance of a metallic object from the front of the switch.
Rack PC	A PC that is composed of Units mounted to one or more Racks. This configuration is the most flexible, and most large PCs are Rack PCs. A Rack PC is the opposite of a Package-type PC, which has all of the basic I/O, storage, and control functions built into a single package.
RAM	[R(andom) A(ccess) M(emory)] RAM will not retain data when power is disconnected. Therefore data should not be stored in RAM.
register/registered	Storing text and graphics in the RAM/ROM card from a personal computer or the ASCII Unit. Graphics that have been written to the RAM/ROM card are referred to as registered messages.
Remote I/O Unit	A Unit that extends the distance an Expansion I/O Unit can be from the CPU.
ROM	[R(ead) O(nly) M(emory)] A type of digital storage that cannot be written to. A ROM chip is manufactured with its program or data already stored in it, and it can never be changed. However, the program or data can be read as many times as desired.
switching capacity	The voltage/current that relay can switch ON and OFF.
stepping motor	An output device that rotates according to signals from the Control System. The rotation is very precise and occurs in pre-defined "steps."
switch	An input device that sends either an ON or OFF signal to the Control System. A switch can be operated either by a person or by the movement of a piece of equipment or material.
system configuration	The arrangement in which Units in a System are connected. This term refers to the conceptual arrangement and wiring together of all the devices needed to comprise the System. In OMRON terminology, system configuration is used to describe the arrangement and connection of the Units comprising a Control System that includes one or more PCs.
Unit	In OMRON PC terminology, the word Unit is capitalized to indicate any product sold for a PC System. though most of the names of these products end with the word Unit, not all do, e.g., a Remote Terminal is referred to in a collective sense as a Unit. Context generally makes any limitations of this word clear.
watchdog timer	A special timer inside the CPU that monitors the PC's cycle time. The watchdog timer sets a flag if the cycle time becomes longer than a certain specified value. This is useful if the correct operation of your System depends on a certain maximum cycle time.
word	In digital circuits, a group of bits. Usually a word consists of four, eight, or sixteen bits. In C-series PCs, a word consists of sixteen bits. Words can be used to store data, or they can be used for I/O.
work bits	Bits in the IR area that are not being used for input or output. These bits can be used in the program in any way desired.

Index

A

ambient temperature, 34

Analog Timer Unit
dimensions, 199
specifications, 175

assembly
Backplane, 35, 38
Connecting Cable, 38
CPU, 35
Expansion I/O Rack, 38
I/O Units, 36
mounting the Units, 37

B

B7A Interface Unit, dimensions, 198

B7A Interface Units
dimensions, 199
Group-2 Units, 179

B7A Link Terminals, 180

Backplane, 35

Backplane Insulation Plate, 49

battery, Memory Unit, replacement, 90

C

C200H
compatibility with, 13
differences with, 11

contact protection circuit, 129

control components, 2

Control System, 2

cooling, fan, 34

CPU, 18
components, 18
DIP switch, 22
indicators, 19
Memory Cassettes, 23
operation modes, 23
peripheral device connector, 22

CPU Rack, 16

current consumption, 188
24-V supply, 193
26-V supply, 193
5-V supply, 189, 190, 191, 192

cycle, 6

cycle time, 6

D-E

dimensions, 193

duct work
I/O wiring, 57
power cables, 57

EC directives
CPU, 8, 18
Power Supply Unit, 25

electrical noise, 55

electrostatic charge, 34

emergency stop circuit, 58

errors
CPU Rack, 81
Expansion I/O Rack, 81
fatal, 79
initialization, 77
Input Unit, 82
message tables, 77-81
non-fatal, 77, 79
Output Unit, 83
programming indications, 76
reading and clearing messages, 76

Expansion I/O Rack, 17, 24

F

factory computer, 2

fatal operating errors, 79

fuse
CPU and power supply, replacement, 86
output, replacement, 86

G

grounding
ground terminal, 48
line ground terminal, 48
wire, 48

Group-2 High-density I/O Units, 28
C-shape, 29
D-shape, 29
dimensions, 197

H

High-density I/O Unit, DIP switch settings, 173

High-density I/O Units, 30

- dimensions, 197
- DIP switch settings, 30
- limitations, 172
- specifications, 154
- unit number settings, 30

humidity, 34

I

I/O Unit Cover, 51

I/O Units, 26

- Group-2 High-density I/O Units, 28
- High-density I/O Units, 30
 - DIP switch settings, 30
 - unit number settings, 30
- Standard I/O Units, 27

inductive load surge suppressor, 56

input devices, 4

installation, environment

- ambient conditions, 34
- cooling, 34
- cooling fan, 34
- Rack clearance, 34

interlock circuit, 58

Interrupt Input Unit, dimensions, 198

L

Ladder Support Software, 73

leakage current

- input, 53
- output, 54

limit switch, 4

LSS. *See* Ladder Support Software

M

Memory Cassette, 23

- installing, 43

models, C200HS, 93

mounting, Racks

- conduit, 39
- preventing noise, 35

mounting requirements, 41

- DIN track mounting, 41
 - 16-mm DIN track, 41
 - 7.3-mm DIN track, 41
- DIN track mounting bracket, 42
- procedure, 42

N-O

non-fatal operating errors, 77, 79

one-to-one link, wiring, 203

output devices, 4

P

PC

- block diagram, 5
- flowchart, 7
- operation, 5
- role of, 4

PCs, cooling, 34

photoelectric switch, 4

power consumption, 188

power interruptions, Programmable Controller, 59

power supply, 25

- AC power supply, 20, 25
- DC power supply, 21, 26

precautions, general, xi

process control computer, 2

Programming Console, 62

- checking initial C200HS operation, 64
- Hand-held, 3

proximity switch, 4

R

relay, printed circuit board, 88

relays, Output Unit, replacement, 87

RS-232C, port specifications, 202

RS-232C connector, 19

RS-232C port

- connecting devices, one-to-one link, 203
- specifications, 202, 203
- wiring example, 202

S

servomotor drivers, 3

servomotors, 3, 5

short-circuit protection, 54

Slave Rack, 17

solenoid, 5

Special I/O Units, 67

specifications

- C200H-ID501, 154
- C200H-IA121, 106
- C200H-IA122, 107
- C200H-IA122V, 107
- C200H-IA221, 108
- C200H-IA222, 109
- C200H-IA222V, 109
- C200H-ID001, 110
- C200H-ID002, 111
- C200H-ID211, 112, 141
- C200H-ID212, 113
- C200H-ID215, 155
- C200H-ID216, 143
- C200H-ID217, 144
- C200H-ID218, 146
- C200H-ID219, 147
- C200H-IM211, 114
- C200H-IM212, 115
- C200H-MD115 (dynamic), 167
- C200H-MD115 (static), 166
- C200H-MD215 (dynamic), 170
- C200H-MD215 (static), 169
- C200H-MD501 (dynamic), 164
- C200H-MD501 (static), 163
- C200H-OA121-E, 116
- C200H-OA122-E, 117
- C200H-OA222V, 118
- C200H-OA223, 119
- C200H-OA224, 120
- C200H-OC221, 121
- C200H-OC222, 122
- C200H-OC222V, 126
- C200H-OC223, 123
- C200H-OC224, 124
- C200H-OC224V, 128
- C200H-OC225, 125
- C200H-OC226, 127
- C200H-OD211, 131
- C200H-OD212, 132
- C200H-OD213, 133
- C200H-OD214, 134
- C200H-OD215 (dynamic), 161
- C200H-OD215 (static), 160
- C200H-OD216, 136
- C200H-OD217, 137
- C200H-OD218, 149
- C200H-OD219, 150
- C200H-OD21A, 139
- C200H-OD21B, 152
- C200H-OD411, 138
- C200H-OD501 (dynamic), 158
- C200H-OD501 (static), 157
- C200HS-INT01, 140
- C200H-TM001, 175
- Contact Output Unit, life expectancy, 129
- CPU, 103
- Group-2 B7A Interface Units, 179
- High-density I/O Units, 154
- Power Supply, 103
- Standard I/O Units, 106

SSS. *See* SYSMAC Support Software

Standard I/O Units, 27

- A-shape, 27
- B-shape, 27
- dimensions, 195
- E-shape, 28
- specifications, 106

static electricity, preventing, 34

stepping motor, 5

surge current, output, 55

SYSMAC LINK, 64

SYSMAC NET Link, 65

SYSMAC Support Software, 73

system configuration, 3

- expanding the system, 64

T–W

terminal block, 51

transistor output, residual voltage, 54

wiring

- AC Input Units, 53
- DC Input Units, 51
- examples, 51
- I/O devices, 51
- I/O Units, 51
- power supply, 46

Revision History

A manual revision code appears as a suffix to the catalog number on the front cover of the manual.

Cat. No. W236-E1-07

Revision code

The following table outlines the changes made to the manual during each revision. Page numbers refer to the previous version.

Revision code	Date	Revised content
1	December 1993	Original production
2	August 1994	<p>Page 7: Flowchart changed.</p> <p>Pages 8, 9, 11, 12, 14, 16, 17, 31, 33, 40, 41, 56, 81, 91, 92, 156, 158, 159, 163: New CPU information added.</p> <p>Pages 9, 11: Interrupt information added.</p> <p>Page 9: RS-232C information added.</p> <p>Pages 9, 12, 11, 14, 56, 85, 162: New SYSMAC LINK Units and SYSMAC NET Link Unit information added.</p> <p>Pages 10 to 12: Information in the tables corrected.</p> <p>Page 17: DIP switch pin no. 5 function description changed.</p> <p>Page 43: Backplane Insulation Plate information changed.</p> <p>Page 88: SYSMAC LINK/SYSMAC NET Link Optical Fiber Products added.</p> <p>Pages 151 to 153: Temperature Control Unit, Fuzzy Logic Unit, and Cam Positioner Unit specifications removed.</p>
3	February 1995	<p>Group-2 B7A Interface Units were added beginning on page 156 and to the following pages: 13, 85, 95, 154, 158, 159, and 164–165</p> <p>Page 11: Execution time and number of instructions changed.</p> <p>Page 13: "Link compatible" and accompany text corrected.</p> <p>Page 20: Power supply diagrams added for CPUs.</p> <p>Page 34: Information on Interrupt Input Unit added.</p> <p>Page 35: Caution added.</p> <p>Page 36 and 44: Diagram corrected.</p> <p>Page 39: Corrected first step and table in installation procedure.</p> <p>Page 67: 5-6 SYSMAC Support Software (SSS) added.</p> <p>Page 72: 9D correction added.</p> <p>Page 73: First FAL number changed and "Communications Errors" added.</p> <p>Page 75: Table corrected.</p> <p>Page 78 and 80: Steps added to fuse and relay replacement procedure and illustrations changed.</p> <p>Page 90: Link Adapter model deleted.</p> <p>Page 93: Small correction for LSS. SSS models added.</p> <p>Page 168: RS-232C port specifications added.</p> <p>Minor changes were made to the following pages: 16, 17, 23, 24, 58, 81, 83, 93, 95, and 164.</p>
3A	October 1995	<p>Page 9: Maximum number of I/O points for Remote I/O System with Slave Units corrected to 800 points from 560 points.</p> <p>Pages 12, 13: LSS replaced with SSS in the table.</p> <p>Page 21: Functions for pin 5 in the table corrected. Notes added.</p> <p>Page 26: C200H-ID111 added to table.</p> <p>Page 42: 24-VDC output connections added to the diagram. Text added to the bottom of page.</p> <p>Page 43: Bottom diagram changed and text deleted from the bottom of page.</p> <p>Page 46: Caution removed.</p> <p>Page 63: C200H-DA002 added.</p> <p>Page 81: Note rewritten.</p> <p>Pages 83, 84: DANGER note moved.</p> <p>Pages 85 to 93: Standard models updated and corrected.</p> <p>Page 109: C200H-OA224 added.</p> <p>Page 127: C200H-ID111 added.</p> <p>Page 139 to 153: Some resistance figures removed from the circuit configurations. C200H-OA121-E added. Other minor corrections.</p> <p>Pages 160 and 170: Specifications and notes corrected.</p> <p>Page 173: Current consumptions for C200H-OA121-E, C200H-OA224, C200H-ID111, and C200H-DA002 added.</p>
4	August 1996	<p>Pages 8, 9, 10, 13, 16, 18, 19, 20, 35, 37, 44, 46, 86, 87, 97, 98, 99, 173, 174, 178: New C200HS-CPU01-EC/CPU21-EC/CPU23-EC CPU and related information added.</p> <p>Pages 8, 18, 20, 87: Conformance to EC directives and related information added for C200HS-CPU03-E CPU.</p> <p>Pages 3, 12, 13, 61, 91, 95, 177: C200HS-SLK12/SLK22 SYSMAC LINK Units changed to C200HW-SLK13/SLK14/SLK23/SLK24.</p> <p>Page 13: C200H-RT201-C added to Remote I/O (Wired) Slave Units.</p> <p>Page 21: Pin No. 6 function clarified.</p> <p>Pages 21, 58, 95, 179: C200HS-CN222 and C200HS-CN422 Connecting Cables added.</p> <p>Pages 24, 44, 46, 87, 97, 173, 178: New C200H-PS221-C Power Supply Unit and related information added.</p> <p>Pages 24, 45: Terminal connections changed for C200H-PS211.</p> <p>Pages 24, 87: Conformance to EC directives and related information added for C200H-PS211 Power Supply Unit.</p> <p>Pages 25, 26, 97: E-shape Units added.</p> <p>Pages 36, 88, 128, 176: C200H-OD21A added.</p> <p>Page 46: Notes added to the top and bottom of the page.</p> <p>Page 82: Fuse specifications table added.</p> <p>Pages 88, 101, 175: C200H-IA122V added.</p> <p>Pages 88, 103, 175: C200H-IA222V added.</p> <p>Pages 88, 112, 176: C200H-OA222V, C200H-OA223, C200H-OA122-E added. C200H-OA222 deleted.</p> <p>Page 111: Fuse voltage corrected for C200H-OA121-E circuit configuration.</p> <p>Page 113: Residual voltage for C200H-OA224 corrected. Minor corrections made to the circuit configuration.</p> <p>Page 91, 177: CompoBus Units added.</p> <p>Page 92: 3G2A9-AL006-E deleted from <i>Link Adapters</i>.</p> <p>Page 163: Minor addition made to the B7A transmission delay</p> <p>Pages 171, 172: Voltage correction made for the common power supply in the diagrams.</p> <p>Pages 179 to 185: Dimensions section rearranged and corrected.</p>
5	April 1997	<p>PLP section added in from of Section 1. Relay Output Units changed to Contact Output Units throughout the manual. C200H-CPU23-EC removed throughout the manual.</p> <p>Page 27: Note on C200H-OC226 dimensions added.</p> <p>Pages 85 to 87: Output Unit Relay and Output Units added to the procedure.</p> <p>Pages 90, 122, 180, 182: C200H-OC222V, C200H-OC224V, and C200H-OC226 Contact Output Units added.</p> <p>Page 94: Relay added to <i>Optional Products</i>.</p> <p>Page 123: New Contact Output Units reflected.</p> <p>Page 186: C200H-OC226 dimensions added.</p>
6	June 1999	<p>Page 28: C200H-ID218, C200H-ID219, and C200H-OD21B added.</p> <p>Page 46: Crimp terminal information added.</p> <p>Page 53: Precautions for connecting two-wire sensors added.</p> <p>Pages 92, 114: C200H-OA221 removed from <i>C200H Standard I/O Units</i>.</p> <p>Page 93: C200H-ID218, C200H-ID219, and C200H-OD21B added to <i>C200H Group-2 High-density I/O Units</i>.</p> <p>Page 101: Vibration, shock, grounding, and enclosure rating information corrected.</p> <p>Pages 131, 132: C200H-OD212 and C200H-OD213 circuit configurations corrected.</p> <p>Page 138: C200H-OD21A information corrected.</p> <p>Page 145: C200H-ID218 and C200H-ID219 information added.</p> <p>Page 148: C200H-OD21B information added.</p> <p>Page 186: C200H-ID218, C200H-ID219, and C200H-OD21B added to <i>Current Drawn from 5-V Supply for Group-2 High-density I/O Units</i>.</p>
07	March 2003	<p>Page 22: Information in table changed in several places.</p> <p>Pages 149, 151, 160, 162, 169, 171: Minor changes made to circuit configuration diagrams.</p> <p>Page 180: Information related to connectable B7A Link Terminals changed and added in several places.</p> <p>Pages 202, 203: System configuration added and connection diagrams corrected.</p>

OMRON Corporation

FA Systems Division H.Q.

66 Matsumoto

Mishima-city, Shizuoka 411-8511

Japan

Tel: (81)55-977-9181/Fax: (81)55-977-9045

Regional Headquarters

OMRON EUROPE B.V.

Wegalaan 67-69, NL-2132 JD Hoofddorp

The Netherlands

Tel: (31)2356-81-300/Fax: (31)2356-81-388

OMRON ELECTRONICS LLC

1 East Commerce Drive, Schaumburg, IL 60173

U.S.A.

Tel: (1)847-843-7900/Fax: (1)847-843-8568

OMRON ASIA PACIFIC PTE. LTD.

83 Clemenceau Avenue,

#11-01, UE Square,

Singapore 239920

Tel: (65)6835-3011/Fax: (65)6835-2711

OMRON

Authorized Distributor:

Cat. No. W236-E1-07

C200HS Programmable Controllers

INSTALLATION GUIDE

OMRON

Mouser Electronics

Authorized Distributor

Click to View Pricing, Inventory, Delivery & Lifecycle Information:

Omron:

[3G2A9-AL001](#) [3G2A9-AL002-E](#) [3G2A9-AL002-PE](#) [3G2A9-AL004-E](#) [3G2A9-AL004-PE](#) [3G5A2-OF002-100M](#)
[3G5A2-OF011](#) [3G5A2-OF111](#) [3G5A2-OF301](#) [3G5A2-OF311](#) [3G5A2-OF511](#) [B500-AL007-P](#) [C200H-ATT33](#) [C200H-ATT53](#) [C200H-ATT83](#) [C200H-BC031-V2](#) [C200H-BC051-V2](#) [C200H-BC081-V2](#) [C200H-BC101-V2](#) [C200H-CE001](#)
[C200H-CE002](#) [C200H-CN131](#) [C200H-CN220-EU](#) [C200H-PS211](#) [C200H-PS221](#) [C200HS-ME16K](#) [C200HS-MP16K](#)
[C500-CE405](#) [C500-CN222-EU](#) [C500-Y9LS10-EV3](#) [C500-Y9LS15-EV3](#) [G79-Y050C](#) [G79-Y150C](#) [G79-Y200C](#) [G79-Y500C](#) [G7T-1112S-DC12V](#) [G7T-1122S-AC100/110V](#) [G7T-1122S AC110/120](#) [C500-CE403](#)

Компания «Life Electronics» занимается поставками электронных компонентов импортного и отечественного производства от производителей и со складов крупных дистрибьюторов Европы, Америки и Азии.

С конца 2013 года компания активно расширяет линейку поставок компонентов по направлению коаксиальный кабель, кварцевые генераторы и конденсаторы (керамические, пленочные, электролитические), за счёт заключения дистрибьюторских договоров

Мы предлагаем:

- Конкурентоспособные цены и скидки постоянным клиентам.
- Специальные условия для постоянных клиентов.
- Подбор аналогов.
- Поставку компонентов в любых объемах, удовлетворяющих вашим потребностям.
- Приемлемые сроки поставки, возможна ускоренная поставка.
- Доставку товара в любую точку России и стран СНГ.
- Комплексную поставку.
- Работу по проектам и поставку образцов.
- Формирование склада под заказчика.
- Сертификаты соответствия на поставляемую продукцию (по желанию клиента).
- Тестирование поставляемой продукции.
- Поставку компонентов, требующих военную и космическую приемку.
- Входной контроль качества.
- Наличие сертификата ISO.

В составе нашей компании организован Конструкторский отдел, призванный помогать разработчикам, и инженерам.

Конструкторский отдел помогает осуществить:

- Регистрацию проекта у производителя компонентов.
- Техническую поддержку проекта.
- Защиту от снятия компонента с производства.
- Оценку стоимости проекта по компонентам.
- Изготовление тестовой платы монтаж и пусконаладочные работы.



Тел: +7 (812) 336 43 04 (многоканальный)

Email: org@lifeelectronics.ru